

FALK™

A REGAL REYNORD BRAND

Falk™ Type PC Pump & Cooler Assemblies (Water/Oil) - Selection Guide All Falk Gear Drives

Regal Rexnord
Application Engineering: 800 626 2093
PTSAAppEng@regalrexnord.com
regalrexnord.com/Falk

FORM
MCM-131-310-FK
Revised
April 2025

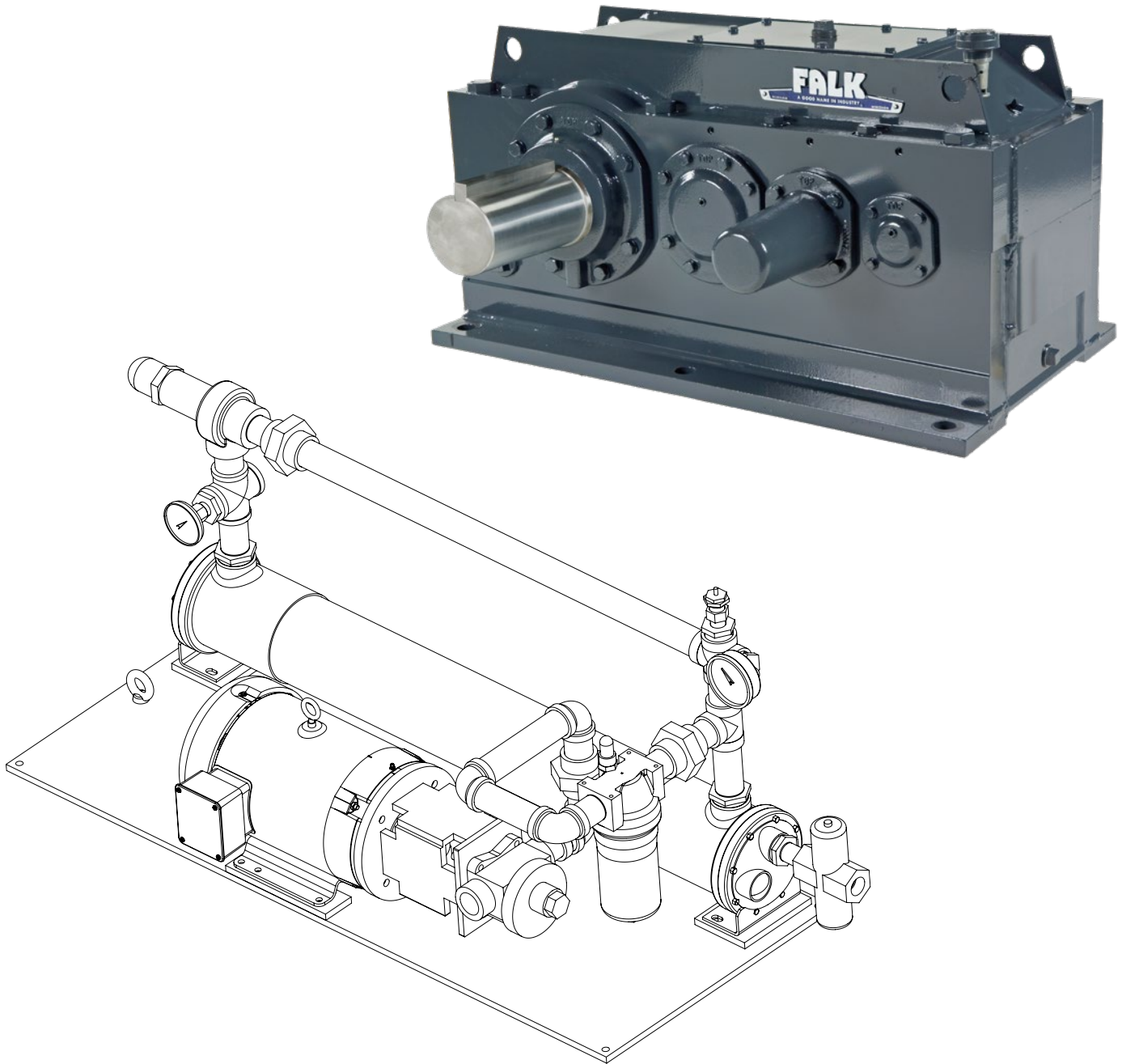

SAFETY MESSAGE DEFINITIONS

⚠ DANGER Indicates a hazard which, if not avoided, will result in serious injury or death.

⚠ WARNING Indicates a hazard which, if not avoided, could result in serious injury or death.

⚠ CAUTION Indicates a hazard which, if not avoided, could result in minor or moderate personal injury.

NOTICE Indicates information considered important, but not hazard-related (e.g. messages relating to property damage).

GENERAL SAFETY INSTRUCTIONS

⚠ WARNING

- Read and follow all instructions carefully.
- Disconnect and lock out power before installation and maintenance. Working on or near energized equipment can result in severe injury.
- Do not operate equipment without guards in place. Exposed equipment can result in severe injury or death.

- Read and understand the information in this section and in this manual completely before installing, operating or maintaining this equipment. Failure to follow this instruction could result in severe injury or death.

⚠ CAUTION

- Perform periodic inspections. Equipment may fail prematurely and could become unsafe if not properly inspected and maintained. Failure to follow this instruction could result in mild or moderate personal injury.

Type PC Pump & Cooler Assemblies With Water/Oil Heat Exchanger

When compact gear drives require assistance to dissipate thermal energy, Regal Rexnord offers the following cooling accessories:

- Shaft Driven Cooling Fans
- Electric Cooling Fans
- Cooling Tubes
- Type PC Pump and Cooler Assembly (Water/Oil)
- Type PA Pump and Cooler Assembly (Air/Oil)

Regal Rexnord recommends the most economical cooling accessory that meets the demands of the application and any associated customer specifications. Pump & cooler assemblies are commonly suggested when the thermal requirements exceed that which can be accommodated by shaft driven fans, electric cooling fan, or cooling tubes.

NOTICE: Pump and cooler assemblies described in this guide are offered as **oil cooling** devices for use on gear drives that are splash lubricated (splash assures adequate oil flow to bearings and gearing regardless of whether the pump & cooler assembly is activated). When gear drives require pressure lube, jet lube, or other dependencies associated with continuous flow of lubrication supplied by the lube pump, refer to Regal Rexnord.

This selection guide covers Type PC Pump & Cooler Assemblies with Water/Oil Heat Exchanger. Five sizes are available. Each assembly includes oil pump and associated pump motor, coupling (motor to pump), water/oil heat exchanger, oil filter, heat exchanger bypass valve, all pre-assembled with preformed hydraulic tubing and tube fittings on a common steel mounting plate which can be bolted to a suitable foundation.

Table 1, provides the thermal capacity of each size of Type PC Pump and Cooler Assembly, as well as a description of the individual components that make up each size. Regal Rexnord reserves the right to substitute equivalent brands of components.

Type PC Pump & Cooler Assemblies are furnished to be floor mounted. Regal Rexnord furnishes only oil piping from the pump to the heat exchanger inlet. All water piping is customer furnished. Refer to **Table 3** for recommended lube line sizes of the customer furnished oil suction and oil discharge lines.

When requested, and where determined feasible by Regal Rexnord Engineering, pump and cooler assemblies may be mounted directly to the gear drive at an additional charge.

Pre-selected thermometer and pressure gauges are standard. Contact Regal Rexnord for other requirements including switch

to activate warning device, flow indicator/switch, oil heater, oil sump tank, water control device, non-standard components, etc.

Oil Immersion Heater

Lubricant viscosity recommendations shown in Regal Rexnord service manuals for enclosed gear drives are applicable to these pump and cooler assemblies. However, for operation at ambient temperatures at less than 50° F (10° C), a gear drive equipped with Type PC Pump & Cooler Assembly should also be equipped with an oil immersion heater (extra charge option).

Temperature Switch

When gear drives equipped with pump and cooler assemblies are started after extended idle periods, lubricant in the gear drive sump will not be at operating temperature, and may be at viscosities exceeding 8000 SSU (1725 cSt). Startups with lubricant at elevated viscosity levels can result in pump cavitation, pump motor overload, and damage to components. Where cold start situations are anticipated, specify a temperature switch (extra charge option) when ordering the pump and cooler assembly.

Installation & Maintenance

WARNING! Lock out power source and remove all external loads from the gear drive before servicing the gear drive or accessories. For detailed maintenance instructions and specifications for components such as heat exchanger, oil filter, pump, etc, refer to the product manufacturer's literature.

When ordering parts, or requesting information, provide the Regal Rexnord M.O. Number, gear drive size, H.S. shaft rpm, ratio, and date that are stamped on the gear drive nameplate.

For floor-mounted pump & cooler assemblies, connect oil and water lines after the gear drive has been installed. Always locate floor-mounted assemblies in close proximity to the gear drive to minimize pressure drop in the oil lines. It is recommended that oil pumps be mounted below the gear drive oil level to maintain a prime. Minimum lube line sizes are indicated in **Table 3**.

When pump and coolers assemblies are mounted on the gear drive by Regal Rexnord, all oil line connections are completed by Regal Rexnord, and only the water lines require connection during installation.

Refer to gear drive certified prints for final designation of components, and exact location and description of inlet/outlet hookup points.

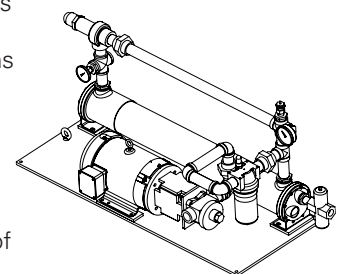

Install a water control device in the water line to the heat exchanger to regulate water flow rate through the heat exchanger. It is also recommended that a water flow gauge be installed between the control device and the heat exchanger to determine actual water flow rate.

Connect water inlet line to the heat exchanger and run the discharge line to an open drain to prevent back pressure. Do not use a throttling valve or shut-off valve between heat exchanger and drain.

Quick Selection Method – Type PC Pump & Cooler Assemblies

Prior to filling gear drives with oil, remove the inspection plate and flood the oil troughs to insure a generous flow of oil to the bearings.

(Note: Optimized pump & cooler assemblies for Sizes 385A1 – 525A1 Single Reduction Gear Drives are pre-selected in **Table 2**)

The following selection method is conservative, and assumes the pump & cooler assembly will dissipate the complete thermal burden. Contact Regal Rexnord when an optimized selection is required. Optimized selections also take into account thermal dissipation contribution from gear drive housing surfaces, and gear drive sump capacity.

1. Determine the Power Rating of the Prime Mover. It is not necessary to use a service factor.
2. Determine BTU/Hr that will be used to select the pump & cooler assembly as follows:

If the Prime Mover is rated in Horsepower

Single Reduction Gear Drives –
BTU/Hr = Power Rating of the Prime Mover (HP) X 38.2

Double Reduction Gear Drives –
BTU/Hr = Power Rating of the Prime Mover (HP) X 76.4

Triple Reduction Gear Drives –
BTU/Hr = Power Rating of the Prime Mover (HP) X 114.6

If the Prime Mover is rated in Kilowatts

Single Reduction Gear Drives –
BTU/Hr = Power Rating of the Prime Mover (kW) X 51.3

Double Reduction Gear Drives –
BTU/Hr = Power Rating of the Prime Mover (kW) X 102.5

Triple Reduction Gear Drives –
BTU/Hr = Power Rating of the Prime Mover (kW) X 153.7

3. From **Table 1**, choose the size of pump & cooler assembly that has a Max Dissipation BTU/Hr that equals or exceeds the BTU/Hr that was determined in Step 2.

Note: Each size of pump & cooler assembly has two values for Max Dissipation BTU/Hr, one value when the pump motor is 60 Hz, and a lower value when the pump motor is 50 Hz.

Selection Example

- Prime mover is 750 HP at 1750 rpm
- Available electric source to drive pump motor is 60 Hz
- Mechanical Service Factor is 1.25
- Nominal ratio of the gear drive is 5.60:1
- The gear drive is splash lubricated

From Selection Guide [131-110](#):

- Size of the gear drive is 425A2, double reduction, (mechanical service factor = $1215/750 = 1.62$)
- Power Rating of the Prime Mover is 750 HP
- BTU/Hr for double reduction gear drive, with Prime Mover rated in HP = $750 \text{ HP} \times 76.40 = 57,300 \text{ BTU/Hr}$

TABLE 1 - Specifications for Type PC Pump & Cooler Assemblies (Water / Oil) •

Pump & Cooler Assembly	205PC	210PC	220PC	230PC	240PC					
Pump	HAIGHT 3U	HAIGHT 5U	HAIGHT 10U	HAIGHT 20U	HAIGHT 30U					
Pump Adapter	HAIGHT Z56RO	HAIGHT Z56RO	HAIGHT Z182S	HAIGHT Z213D	HAIGHT Z213D					
Coupling	LOVEJOY L75	LOVEJOY L75	LOVEJOY L95	LOVEJOY L100	LOVEJOY L100					
Heat Exchanger & Water Flow Rate*	ITT 04024 BCF 5-030-04-024-005 3-25 GPM	ITT 04036 BCF 5-030-04-036-005 4-30 GPM	ITT 04036 BCF 5-030-04-036-005 4-30 GPM	ITT 06048 BCF 5-030-06-048-005 6-40 GPM	ITT 08060 TCF 5-030-08-060-005 10-45 GPM					
Pressure Relief Valve	FULFLO VJ SET @ 60PSI	FULFLO VJ SET @ 60PSI	FULFLO VJ SET @ 60PSI	FULFLO VJ SET @ 60PSI	FULFLO VJ SET @ 60PSI					
Filter - 20 micron	PARKER 15CN-1-20QE	PARKER 15CN-2-20QE	PARKER 40CN-2-20QE	PARKER 40CN-2-20QE	PARKER 40CN-2-20QE					
Filter Element - 20 micron	PARKER 936701Q	PARKER 936705Q	PARKER 936712Q	PARKER 936712Q	PARKER 936712Q					
Pressure Gauge	ASHCROFT TYPE 1009 Model 35-1009-AW-02B	ASHCROFT TYPE 1009 Model 35-1009-AW-02B	ASHCROFT TYPE 1009 Model 35-1009-AW-02B	ASHCROFT TYPE 1009 Model 35-1009-AW-02B	ASHCROFT TYPE 1009 Model 35-1009-AW-02B					
Thermometer	ASHCROFT 30-EI-60R-040-XCS	ASHCROFT 30-EI-60R-040-XCS	ASHCROFT 30-EI-60R-040-XCS	ASHCROFT 30-EI-60R-040-XCS	ASHCROFT 30-EI-60R-040-XCS					
Thermostatic Control Valve	STERLING 56T0820006A	STERLING 56T0820006A	STERLING 56T0820006A	STERLING 56T0820006A	STERLING 56T0820006A					
Motor Options (Specify One)										
60 Hz AC Electric Motor 208-230/460 Volts	3Phase,60Hz,TEFC,56C, .75 HP,1800 RPM	3Phase,60Hz,TEFC,56C 1.00 HP,1800 RPM	3Phase,60Hz,TEFC,184TC 5.00 HP,1800 RPM	3Phase,60Hz,TEFC,213TC 7.5 HP,1800 RPM	3Phase,60Hz,TEFC,213TC, 7.5 HP, 1800 RPM					
50 Hz AC Electric Motor 220/380-440 Volts	3Phase,50Hz,TEFC,56C .75 HP,1500 RPM	3Phase,50Hz,TEFC,56C 1.00 HP,1500 RPM	3Phase,50Hz,TEFC,184TC 5.00 HP,1500 RPM	3Phase,50Hz,TEFC,213TC 7.5 HP,1500 RPM	3Phase,50Hz,TEFC,213TC, 7.5 HP,1500 RPM					
60 Hz AC Electric Motor 575 Volt	3Phase,60Hz,TEFC,56C .75HP,1800 RPM	3Phase,60Hz,TEFC,56C 1.00 HP,1800 RPM	3Phase,60Hz,TEFC,184TC 5.00 HP,1800 RPM	3Phase,60Hz,TEFC,213TC 7.5 HP,1800 RPM	3Phase,60Hz,TEFC,213TC, 7.5 HP, 1800 RPM					
Pump Oil Flow Rate † Max Dissipation BTU/Hr †	@60Hz 3 GPM 19,300	@50Hz 2.5 GPM 16,300	@60Hz 4.5 GPM 31,000	@50Hz 3.6 GPM 25,700	@60Hz 11.6 GPM 62,400	@50Hz 9.5 GPM 52,900	@60Hz 20 GPM 104,600	@50Hz 16.4 GPM 89,500	@60Hz 29GPM 198,300	@50Hz 24GPM 169,000

• Regal Rexnord reserves the right to substitute equivalent brands of components.

* The water flow rate can be adjusted within the flow range shown in Table 1 to maintain a drive operating temperature at 160°F (71°C). The minimum value of the range is for clean water at a minimum velocity to prevent fouling of the tube bundle. However, a water flow rate of 2 times this minimum value may be required to prevent any suspended solids in the water from settling. The maximum value of the range is based on a maximum velocity not to be exceeded, thereby avoiding erosion of the tube bundle.

† Heat dissipation values are based on a 1:1 oil/water flow rate, 90°F (32°C) inlet water temperature, and maximum inlet water pressure of 100psig.

Type PC Pump & Cooler Assemblies

Sizes 205PC thru 240PC – Dimensions – Inches

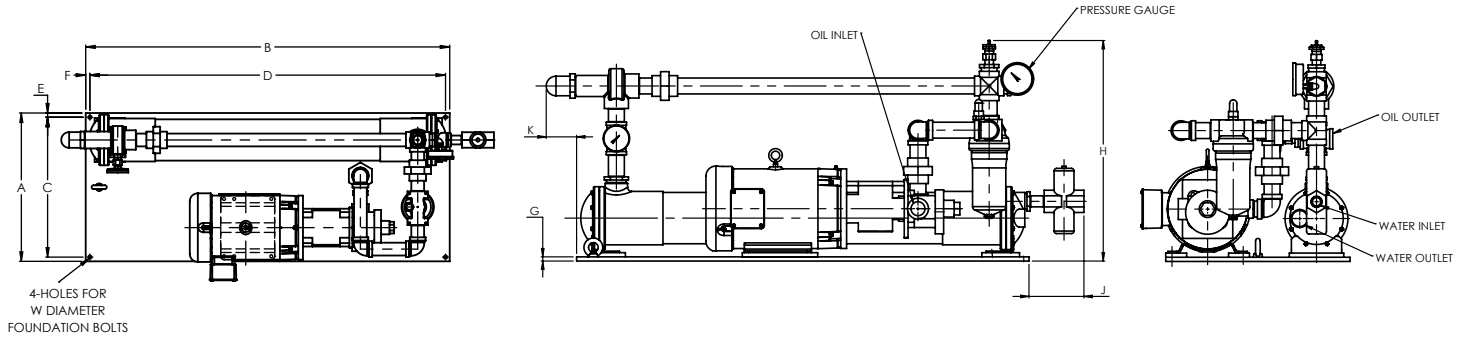

SIZE ★	A	B	C	D	E	F	G	H	J	K	W	Wt lb
205PC	14.00	29.00	12.75	27.75	0.63	0.63	0.50	20.91	6.43	0.56	0.500	200
210PC	14.00	42.00	12.75	40.75	0.63	0.63	0.50	21.77	6.08	0.56	0.500	220
220PC	17.50	41.50	16.25	40.25	0.63	0.63	0.50	24.00	6.83	1.25	0.500	310
230PC	22.00	54.00	20.75	52.75	0.63	0.63	0.50	26.32	6.56	3.63	0.500	350
240PC	24.00	68.00	22.50	66.50	0.75	0.75	0.50	29.47	6.60	1.88	0.625	560

★ Drawings are representative and may not agree in exact detail for all sizes of Pump and Cooler Assembly. Dimension are for reference only and are subject to change without notice unless certified.

Note: When Falk™ gear drives are purchased with pump and cooler assemblies, certified prints are sent via Regal Rexnord Transmittal Letter to the return address stated on the purchase order. Certified prints include final designation of components, and exact location and description of inlet/outlet hookup points.

Pump & Cooler Selections

TABLE 2 – Pre-Selected Type PC Pump & Cooler Assemblies – Sizes 385A1 thru 525A1 Single Reduction Gear Drives

H.S. Shaft RPM of GEAR DRIVE	DRIVE SIZE							
	385A1	405A1	425A1	445A1	465A1	485A1	505A1	525A1
1750	210	210	220	220	230	230	240	240
1430	210	210	220	220	230	230	240	240
1170	210	210	210	210	220	230	230	240
870	210	210	210	210	220	230	230	240
720	210	210	210	210	220	220	220	230
580	210	210	210	210	220	220	220	230

TABLE 3 – Type PC Pump & Cooler Assemblies – Minimum Lube Line Sizes

Lube Line Function	Lube Line Length, Feet	Minimum Lube Line Inside Diameter, Inches				
		PC Size				
		205PC	210PC	220PC	230PC	240PC
Oil Suction Line Gear Drive to Pump Inlet	3	1.00	1.00	1.25	1.75	2.00
	5	1.00	1.25	1.50	1.75	2.00
	10	1.25	1.50	1.75	2.00	2.25
	15	1.50	1.50	2.00	2.25	2.50
	20	1.50	1.75	2.00	2.25	2.75
	25	1.50	1.75	2.25	2.50	2.75
Oil Discharge Line Heat Exchanger Outlet to Gear Drive	3	0.75	0.75	1.00	1.25	1.50
	5	0.75	1.00	1.25	1.25	1.50
	10	1.00	1.00	1.25	1.50	1.75
	15	1.00	1.25	1.50	1.75	2.00
	20	1.25	1.25	1.50	1.75	2.00
	25	1.25	1.25	1.75	2.00	2.00
30	1.25	1.50	1.75	2.00	2.25	

- Notes:
1. Minimum lube line sizes assume the use of a lubricant meeting Regal Rexnord recommendations, and that lubricant entering the oil inlet of the pump is at a nominal viscosity not exceeding 8000 SSU (1725cSt).
 2. Assumes pump inlet located below gear drive outlet.
 3. To achieve optimal system performance, it is strongly recommended that pump and cooler assemblies be located as close as possible to the gear drive, thereby minimizing the length of lube lines. Lube lines should be constant diameter, and free of unnecessary bends and elbows. Observing these recommended measures will reduce the potential for line losses (pressure drop) and cavitation.



The proper selection and application of products and components, including assuring that the product is safe for its intended use, are the responsibility of the customer. To view our Application Considerations, please visit <https://www.regalrexnord.com/Application-Considerations>.

To view our Standard Terms and Conditions of Sale, please visit <https://www.regalrexnord.com/Terms-and-Conditions-of-Sale>.

"Regal Rexnord" is not indicative of legal entity. Refer to product purchase documentation for the applicable legal entity.

Regal Rexnord and Falk are trademarks of Regal Rexnord Corporation or one of its affiliated companies.

© 1995, 2025 Regal Rexnord Corporation, All Rights Reserved. MCM-131-310-FK-EN-US 04/25

