

TABLE OF CONTENTS

SECTION I — INTRODUCTION

Introduction	2
Basic Operation and Design	2
Sectional View and Component Identification	2
Nameplate Information	2

SECTION II — INSTALLATION

Handling of Reducer	3
Reducer Mounting	3
Mounting of Transmission Accessories	4
Motors (Standard Units)	4
Couplings	5
Sprockets or Sheaves	5

SECTION III — LUBRICATION

Lubricant Selection Process	6
Lubricant Changes & Analysis	7
Stored & Inactive Gear Drives	7
Food Grade Lubricants	10
Food Grade Lubrication Selection Process	10
Food Grade Lubricant Changes & Analysis	10
Stored & Inactive Gear Drives	11

SECTION IV — START-UP

Pre Start-Up Checklist	12
Initial Start-Up	12
Prime Mover	12
Reducer Rotation	12
Start-Up	12
Post Start-Up Checklist	12

SECTION V — MAINTENANCE

Filling Oil	13
Draining Oil	13
Adding Grease to Reducer Seals	13
Replacing Seals in Service	13

SECTION VI — DISASSEMBLY AND ASSEMBLY

Required Equipment	14
Taking Reducer out of Service	14
Replacing Seals	14
Removing Seals Carrier	14
Removing Seals From Seals Carrier	14
Installing New Seals	15
Installing Seal Carrier Input/output Shaft Assembly	16
Replacing Bearings — Input/Output Shaft Assemblies	16
Removing Input or Output Shaft Assemblies to Replace Bearings	16
Disassembling Input or Output Shaft Assemblies to Replace Bearings	17
Installing Bearing Cups into Input or Output Housings	18
Assembling Input or Output Shaft Assemblies	18
Setting Proper Axial Bearing Clearances on Input or Output Shaft Assemblies	19
Measuring Axial Clearance on Input and Output Assemblies	19
Adjusting for too Much Axial Bearing Clearance	20
Adjusting for too Little Axial Bearing Clearance	20
Gear Train Disassembly	20
Gear Train Assembly	21
Fan and Shroud Installation	21
Shroud Clip Installation	21
Fan Installation	21

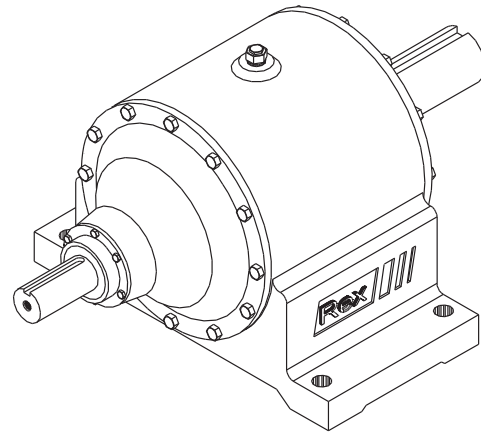

Remote Grease Line Installation	21
Fan Shroud Installation	21

SECTION VII — STORAGE PROCEDURES

Spare Parts Storage	22
Stored and Inactive Reducers	22
Long Term Storage	22

SECTION VIII — TROUBLESHOOTING

Troubleshooting	23
-----------------------	----

SECTION IX — TABLES

Average Weights	24
Torque Requirements	24

SECTION X — TABLES: REPLACEMENT SEALS AND BEARINGS

Bearings for Standard Speed Reducers	25
Seals for Standard Speed Reducers	25

SECTION XI — MAINTENANCE LOG

Maintenance Log	26
Notes	27

SECTION XII — ACCESSORIES

Accessories	28
-------------------	----

Section I — Introduction

The following instructions apply to Jupiter Plus Planetgear 7000 Speed Reducers. To assure long life and performance of the Planetgear 7000 speed reducers, the following practices should be followed.

1.1 BASIC OPERATION AND DESIGN

The Planetgear 7000 unit is a concentric shaft speed reducer that uses a simple planetary design, which utilizes a sun gear as the input, a ring gear as the fixed element, and a planetary carrier as the output. Power is transmitted from the reducer input shaft, through a splined connection to the input gear (sun gear) of the first reduction. The input gear drives the planet gears, which in turn drive the planetary carrier assembly. This carrier assembly is then connected to the next reduction sun gear or to the output shaft through a splined connection. Each carrier represents a single reduction. The reducer output shaft rotates in the same direction as the input shaft, regardless of the number of reductions. Reference Figure 1.2 for a detailed representation.

All gearing has been made of a high grade alloy steel and case hardened for maximum life. Three points of contact, with a minimum of six gear teeth engaged allow for a smooth transmission of power during normal operation and under extreme spike loads. Self contained input and output shaft assemblies use a double row of tapered roller bearings mounted to a steel alloy shaft to provide high

overhung and thrust load capacity. This feature also keeps all external shaft forces isolated from the gearing. Included in both shaft assemblies are two seals with a grease purgeable cavity between them. This design prevents contamination from entering the gear reducer under extreme conditions. The input shaft assembly also has the ability to add a backstop option to eliminate reducer counter rotation when the input driver is shut off.

1.2 SECTIONAL VIEW AND COMPONENT IDENTIFICATION Reference Figure 1.2

1.3 NAMEPLATE INFORMATION

Note location of serial number and model number on nameplate. When contacting the factory, have the serial number available, as this unique number fully describes the reducer and allows for the most efficient and accurate exchange of information. Reference Figure 1.3 for name plate illustration.

Operation of the reducer shall not differ from the application data warranted on the nameplate. Any deviations from this data requires submission of new application information along with all nameplate data to the factory or service center for approval. All data changes require a revised nameplate.

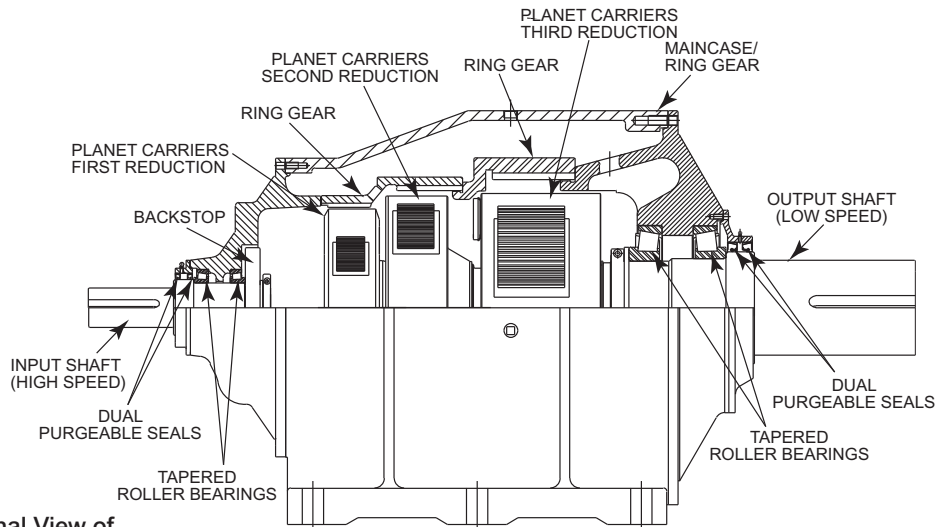

Figure 1.2 Sectional View of a Planetgear Speed Reducer

Rexnord® Planetgear™ 7000
Speed Reducers

REXNORD INDUSTRIES, LLC
WWW.REXNORD.COM

MODEL NO.

SERIAL NO.

CUST. PO.

SIZE

RPM IN

RATIO

RPM OUT

REDUCER ONLY

MAX. TORQUE OUT LB. IN.

SERVICE HP

SERVICE FACTOR

MOTORIZED REDUCER

MOTOR HP

SERVICE CLASS

DATE

OIL CAP.

APPROX. U.S. GAL.

OUTPUT SPEED	AMBIENT TEMPERATURES			
	157-187°F (-5°C-18°C)		207-229°F (100-100°C)	
RPM BELOW 20	ISO-VG 100	AGMA 5	ISO-VG 150	AGMA 4
20 RPM AND ABOVE	100	3	150	4

OUTPUT SPEED	VENUS THRU JUPITER PLUS LUBRICATION			
	157-187°F (-5°C-18°C)		207-229°F (100-100°C)	
RPM BELOW 20	ISO-VG 150 EP	AGMA 4 EP	ISO-VG 320 EP	AGMA 6 EP
20 RPM AND ABOVE	150 EP	4 EP	220 EP	5 EP

IMPORTANT: FILL TO THE LEVEL INDICATED WITH A PREMIUM QUALITY INDUSTRIAL TYPE PETROLEUM EXTREME PRESSURE LUBRICANT (SULFUR-PHOSPHORUS TYPE) CONTAINING OXIDATION, RUST AND FOAM INHIBITORS. FOR DETAILED LUBRICATION INSTRUCTIONS, SEE LUBRICATION BULLETIN. UNDER NORMAL CONDITIONS, THE INITIAL LUBRICANT CHANGE SHOULD BE PERFORMED AFTER 250 HOURS. ALL CHANGES THEREAFTER SHOULD BE PERFORMED EVERY 2500 HOURS OR EVERY SIX MONTHS WHICHEVER COMES FIRST.

P/N 1886026201

Figure 1.3 Reducer Nameplate

Section II — Installation

WELDING — Do not weld on the gear drive or accessories without prior approval from the Factory. Welding on the drive may cause distortion of the housing or damage to the bearings and gear teeth. Welding without prior approval could void the warranty.

EFFECTS OF SOLAR ENERGY — Special measures should be taken to protect drives operating in direct sunlight at ambient temperatures over 100°F (38°C). This protection can consist of a canopy over the drive or reflective paint on the drive. If Neither is possible, a heat exchanger or other cooling device may be required to prevent the reducer sump temperature from exceeding the allowable maximum oil temperature of 200°F (93°C)

2.1 HANDLING OF SPEED REDUCER

Disconnect all mounting bolts from the reducer before lifting. Use lifting chains of ample strength, hooked to the eye bolts when lifting the speed reducer; reference Figure 2.1. Reference Table 15 (Page 24) for reducer weights. Be sure the reducer is properly secured and balanced to prevent shifting during suspension.

WARNING: To avoid personal injury or product damage, never attempt to lift the reducer with an eyebolt threaded into the top of the reducer maincase.

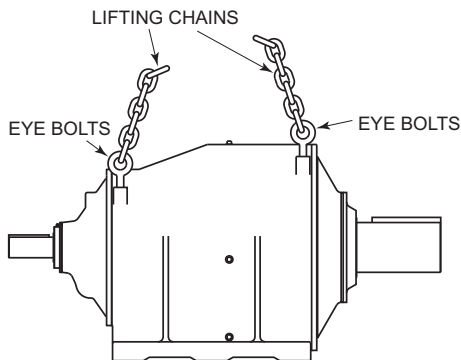

Figure 2.1 Reducer Handling

2.2 REDUCER MOUNTING

It is essential that the speed reducer be securely bolted to a solid, level, and vibration free foundation.

Bolts should be of the correct size to fit mounting holes. They should be SAE Grade 5 or equivalent (Grade 8.8 or better for metric applications). Fasteners shall be torqued according to Table 16 (Page 24). The use of a rigid structural steel base-plate is strongly recommended as a foundation. If a concrete foundation is used, grout structural steel mounting pads into the concrete rather than grouting the reducer directly into the concrete. Allow the concrete to cure before torquing the reducer mounting bolts down.

Align the reducer with driven equipment by placing broad flat shims underneath all mounting pads of the reducer. Start at the low speed end and level across the length and width of the reducer. Check with a feeler gauge to make certain there is no clearance and that all pads are supported to prevent distortion of housing when reducer is bolted down. After the reducer has been aligned with the driven equipment and bolted down, align prime mover to the reducer input shaft. If the reducer is received coupled to a motor, it has been aligned properly at the factory. However, because alignment may have been disturbed during shipment, it is best to check alignment and then realign if necessary. The reliability and long life of the reducer requires careful installation of accessories and accurate alignment of the connecting shafts. Check final alignment of motor shaft, coupling, and reducer shaft after reducer is in final working position.

2.3 MOUNTING OF TRANSMISSION ACCESSORIES

WARNING: When the Planetgear 7000 speed reducer is connected to a motor or driven equipment through the use of couplings, sprockets, gears or belt drives, all rotating parts must be properly guarded with guarding that conforms to OSHA requirements to prevent personal injury or property damage..

2.3.1 MOTORS (STANDARD UNITS)

When direct coupling motors to the Planetgear 7000 reducer, follow the four step process shown below to achieve proper motor to reducer alignment. Refer to coupling manufacture specifications to determine required alignment accuracy. Note: Steps 1 to 4 may have to be repeated several times to achieve manufacturers required accuracies.

STEP 1 (Side view plane)

Correct for *angular misalignment* in the *side view* plant

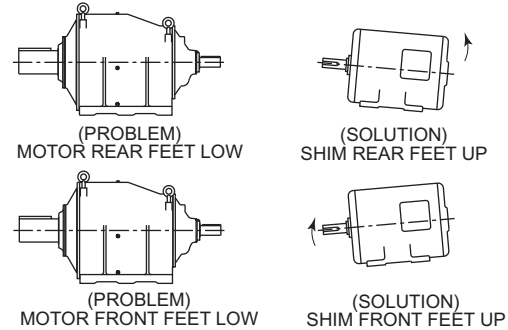

STEP 2 (Side view plane)

Correct for *parallel misalignment* in the *side view* plant

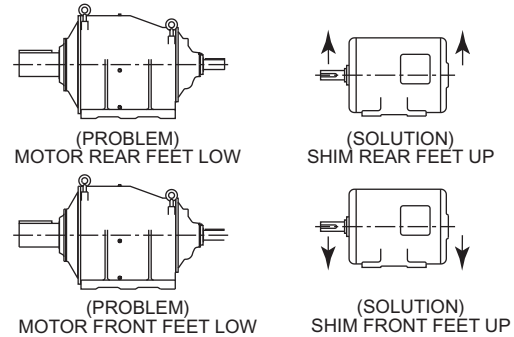

STEP 3 (Top view plane)

Correct for *angular misalignment* in the *top view* plant

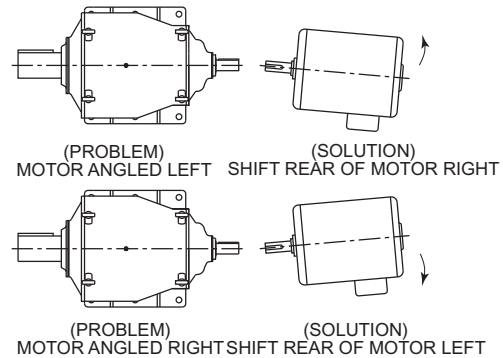

STEP 4 (Top view plane)

Correct for *parallel misalignment* in the *top view* plant

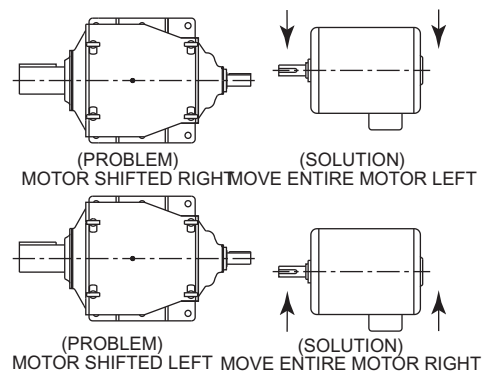

2.3.2 COUPLINGS

Mount the reducer coupling hub on the input shaft and the motor coupling hub on the motor shaft as instructed in the manual shipped with the coupling. If the coupling is not a Rexnord® Omega®, refer to the manufacturers literature for installation instructions. If Rexnord does not mount the motor, the couplings are mounted for shipment only. Coupling bolts and coupling instructions are packed inside the coupling elements. Note: Prior to the installation of the element, check both coupling hubs for the required parallel and angular alignment; Reference Figure 2.3.2.

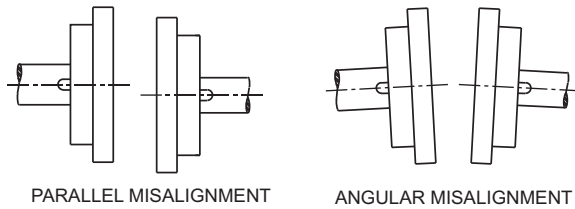

Figure 2.3.2 Parallel and Angular Misalignment

2.3.3 SPROCKETS OR SHEAVES

Prior to installing sprockets or sheaves, review the manufacturers requirements for chain or belt tension and required alignment. When mounting the sprocket or sheave to the shaft, locate it as close as possible to the reducer. This will minimize the overhung load and prolong bearing life.

When using a Planetgear 7000 top motor mount accessory, the belt tension can be changed by varying the height of the motor mount plate. This can be done by adjusting the four threaded support bolts. Reference Figure 2.3.3.

NOTE: Mount sheaves and belts as close to the reducer as possible to avoid undue overhung loading on the bearings.

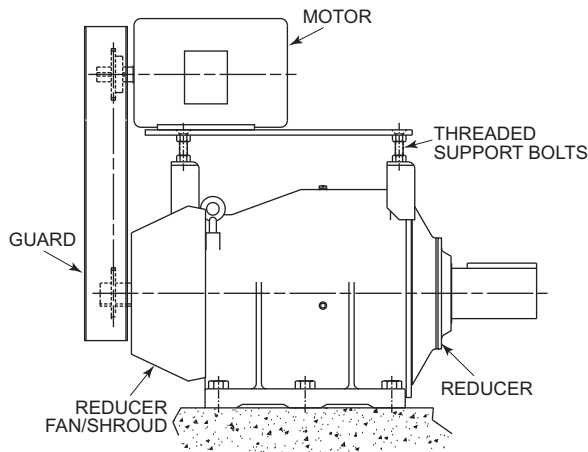

Figure 2.3.3 Planetgear 7000 Top Motor Mount

Section III — Lubrication

INTRODUCTION

Carefully follow instructions on the drive nameplate, warning tags and installation manuals furnished with the drive. Failure to follow instructions will void warranty. Lubricants listed in this manual are typical products ONLY and should not be construed as exclusive recommendations. Industrial type extreme pressure (EP) or industrial type micropitting resistant gear lubricants are the required gear lubricants. They can be formulated using petroleum or synthetic base stocks.

Summary of allowable lubricant types by unit size can be found in Table 1

The section on food grade lubricants provides guidance in selecting lubricants for applications needing this class of lubricants. Food grade lubricants are formulated using petroleum or different types of synthetic base stocks.

WARNING: Failure to use extreme pressure or micropitting resistant type lubricants in Planetgear Jupiter Plus size units will void warranty.

TABLE 1 — Summary Of Allowable Lubricant Types For Planetgear Footmounted Units *

UNIT SIZE	Allowable Lubricant Types
Mercury	Rust & Oxidation Inhibited, Extreme Pressure, Micropitting Resistant
Mars	Rust & Oxidation Inhibited, Extreme Pressure, Micropitting Resistant
Venus	Extreme Pressure, Micropitting Resistant
Atlas	Extreme Pressure, Micropitting Resistant
Luna	Extreme Pressure, Micropitting Resistant
Earth	Extreme Pressure, Micropitting Resistant
Polaris	Extreme Pressure, Micropitting Resistant
Delta	Extreme Pressure, Micropitting Resistant
Neptune	Extreme Pressure, Micropitting Resistant
Neptune Plus	Extreme Pressure, Micropitting Resistant
Orion	Rust & Oxidation Inhibited, Extreme Pressure, Micropitting Resistant
Orion Plus	Extreme Pressure, Micropitting Resistant
Saturn	Rust & Oxidation Inhibited, Extreme Pressure, Micropitting Resistant
Saturn Plus	Extreme Pressure, Micropitting Resistant
Titan	Rust & Oxidation Inhibited, Extreme Pressure, Micropitting Resistant
Titan Plus	Extreme Pressure, Micropitting Resistant
Jupiter	Rust & Oxidation Inhibited, Extreme Pressure, Micropitting Resistant
Jupiter Plus	Extreme Pressure, Micropitting Resistant

* Follow recommendations found in the Lubrication Section of this manual.

LUBRICANT SELECTION PROCESS

1. Refer to Tables 4 and 5 for proper lubricant viscosity grade based on ambient temperature range.
2. Refer to Table 2 for summary of lubricant type.
3. Using proper lubricant table and viscosity grade, select desired lubricant manufacturer and name.
4. Refer to Table 3 for approximate oil capacity to purchase

VISCOSITY (IMPORTANT)

The proper viscosity grade for lubricants is found in Table 4. For synthetic lubricant viscosity grades, refer to table 5 and the "Synthetic Lubricants" paragraphs.

Viscosity grade is determined by ambient air temperature in the immediate vicinity of the gear drive. Lubricant selections must have a pour point at least 10°F (5.5°C) below the expected minimum ambient starting temperature. Temperature ranges for lubricant grade can sometimes be widened if specific application conditions are known.

TABLE 2 — Summary of Lubricant Type and Greases

Petroleum-Based	
Extreme Pressure (EP) See Table 6A	Micropitting Resistant See Table 6B
Synthetic Lubricant, Polyalphaolefin Type (PAO)	
Extreme Pressure (EP) See Table 7A	Micropitting Resistant See Table 7B
Conventional Grease	
See Table 8	
Food Grade Lubricant & Grease	
See See Page 10	

LUBRICANT TYPES

PETROLEUM-BASED LUBRICANTS (TABLES 6A & 6B) – Industrial type petroleum-based extreme pressure (EP) lubricants are common and readily available general purpose gear lubricants.

SYNTHETIC-BASED LUBRICANTS (TABLES 7A & 7B) — Synthetic lubricants of the polyalphaolefin (PAO) type are recommended for cold climate operation, high temperature applications, extended temperature range (all season) operation and/or extended lubricant change intervals. The proper viscosity grade of lubricants is given in Table 5. Usable temperature ranges can sometimes be widened if specific application conditions are known.

WARNING: Polyalkylene glycol (PAG) based synthetic lubricants cannot be used in Planetgear units.

EXTREME PRESSURE (EP) LUBRICANTS (TABLES 6A & 7A) — EP lubricants are manufactures from petroleum or synthetic base lubricants. Anti-scuff is another term used to describe EP lubricants.

MICROPITTING RESISTANT LUBRICANTS (Tables 6B & 7B) — Micropitting resistant lubricants are specially developed for surface hardened earing commonly used in modern industrial gear drives. These lubricants contain additives to resist formation of micropitting and other conventional forms of gear wear. Generally these lubricants are available in limited number of viscosity

WARNING: LUBRICANTS IN FOOD PROCESSING INDUSTRY — Generally, conventional gear lubricants are classified as H2 by NSF (National Sanitation Foundation) since they contain harmful substances and should not be used in the food processing industry. Lubricants registered as H1 by NSF are suitable for food processing applications.

CLIMATE CONDITIONS — Ambient temperature in immediate vicinity of gear drive is very important for determining viscosity grade. Table 4 provides viscosity grade selections for petroleum-based lubricants. See Table 5 for synthetic lubricants.

OIL LEVELS

From the nameplate or the oil capacity chart below, determine the quantity of oil needed. Fill reducer to the oil fill plug as described in the Maintenance section of this manual.

NOTE: Quantities are approximate. Always fill drive to the specified level.

TABLE 3 — Approximate Oil Capacity *

REDUCER SERIES	Reduction Type			
	D/T/Q Gallons	D/T/Q Liters	Quint Gallons	Quint Liters
Jupiter Plus	32	121	34	128

D= Double, T= Triple, Quad= Quadruple, Quint= Quintuple
Double and Triple only.

* Quantities are approximate. Always fill drive to the specified level.

TABLE 4 — Viscosity Grade Recommendation For Petroleum-Based Lubricants

OUTPUT SPEED	AMBIENT TEMPERATURES			
	+15° to +60°F (-9° to +16°C)		+50° to +125°F (+10° to +52°C)	
	ISO-VG	AGMA	ISO-VG	AGMA
RPM BELOW 20	150	4	320	6
20 RPM And ABOVE	150	4	220	5

LUBRICANT CHANGES

OIL ANALYSIS REPORT — Checking oil conditions at regular intervals is recommended. Analyze oil samples approximately every 1,000 hours for petroleum lubricants or every 3,000 hours for synthetic lubricants. In the absence of more specific limits, the guidelines listed below may be used to indicate when to change petroleum or polyalphaolefin type synthetic lubricants:

1. Water content is greater than 500 ppm (parts per million) (0.05%).
2. Iron content exceeds 150 ppm.
3. Silicon (dust/dirt) exceeds 25 ppm, above reference sample from new oil container.
4. Copper content exceeds 75 ppm.
5. TAN (Total Acid Number) 50% increase above reference sample from new oil container.
6. Viscosity changes more than ±15%.
7. Solid particle contamination code exceeds 25/22/18 for particle sizes ≥4/≥6/≥14 microns, respectively per ISO 4406.

Laboratory analysis is recommended for optimum lubricant life and gear drive performance. Oil samples should be taken from the oil level hole, not the drain hole.

PETROLEUM LUBRICANTS — In the absence of oil analysis, change gear oils every 6 months or 2,500 operating hours, whichever occurs first. Change oil more frequently when gear drives operate in extremely humid, chemical or dust laden atmospheres. In these cases, lubricants should be changed every 3 to 4 months or 1,500 to 2,000 hours. If the drive is operated in an area where temperatures vary with the seasons, change the oil viscosity grade to suit the temperature, refer to Table 4. Generally lubricant suppliers can analyze oil from the drive periodically and recommend economical change schedules.

SYNTHETIC LUBRICANTS — In the absence of oil analysis, synthetic lube change intervals can be extended to 8,000 hours depending upon operating temperatures. Laboratory analysis is recommended for optimum lubricant life and drive performance. Change lube with change in ambient temperature, if required. Refer to Table 5.

GREASE PURGED SEALS

All drives are furnished with grease purged seals which minimize the entry of contaminants and abrasive dusts into the drive. Drives are shipped with NLGI #2 grade grease in the seal housing cavities unless otherwise specified.

Whenever changing oil in the drive, purge the seals with one of the NLGI #2 grade greases listed in Table 8. Depending upon the degree of contamination, periodically (at least every six months), purge contaminated grease from seals by slowly pumping fresh bearing grease through the seal, **WITH HAND GREASE GUN**, until fresh grease flows out along the shaft. Wipe off purged grease.

CAUTION: Rapid regreasing with a power grease gun can force grease inward past the seals and plug the oil drain back system causing seal leaks

WARNING: Greases in Table 8 contain harmful substances and are not allowed in the food processing industry. If grease could contaminate the product, as in the food and drug industries, the grease originally supplied with gear drive must be removed and replaced with a grease listed in Table 14. Simply purging grease with a grease gun will not remove all grease and cross-contamination will likely occur. Remove end cover and manually remove grease. Grease registered as H1 by NSF, (National Sanitation Foundation) is suitable for food processing applications.

STORED & INACTIVE GEAR DRIVES

Refer to Section VII (Storage Procedures) for details on stored & inactive gear drives.

TABLE 5 — Viscosity Grade Recommendation for Synthetic Lubricants

Ambient Temperature Range	Cold Climates				Normal Climates			
	-30° to +10°F (-34° to -12°C)		-15° to +50°F (-26° to -10°C)		0° to +80°F (-18° to +27°C)		+10° to +125°F (-12° to -52°C)	
	ISO-VG	AGMA	ISO-VG	AGMA	ISO-VG	AGMA	ISO-VG	AGMA
Below 20 RPM	32	0	68	2	150	4	320	6
20 RPM & Above	32	0	68	2	150	4	220	5

TABLE 6A — Petroleum Based EP (Extreme Pressure) Lubricants ▲
Maximum Operating Temperature of Lubricants 200°F (93°C)

ISO Viscosity Grade	150	220	320
AGMA Viscosity Grade	4	5	6
Viscosity cSt @ 40°C ♦	135-165	198-242	288-352
Viscosity SSU @ 100°F	626-765	918-1122	1335-1632
Manufacturer	Lubricant Name	Lubricant Name	Lubricant Name
Castrol Industrial Lubricants	Alpha SP 150	Alpha SP 220	Alpha SP 320
Chevron / Texaco / Caltex	Meropa 150	Meropa 220	Meropa 320
	Ultra Gear 150	Ultra Gear 220	Ultra Gear 320
Citgo Petroleum Corp.	EP Compounds 150	EP Compounds 220	EP Compounds 320
Exxon Mobil / Esso	Mobilgear 600 XP 150	Mobilgear 600 XP 220	Mobilgear 600 XP 320
Fuchs Lubricants Company	---	GearMaster CLP Oils 220	---
Kluber Lubrication	Kluberoil GEM 1 N 150	---	---
Petro-Canada Lubricants	Enduratex EP 150	Enduratex EP 220	Enduratex EP 320
Phillips 66 / Conoco / 76 Lubricants / Kendall	Extra Duty Gear Oil 150	Extra Duty Gear Oil 220	Extra Duty Gear Oil 320
Shell Oil Co.	Omala S2 G 150	Omala S2 G 220	Omala S2 G 320
Total Lubricants USA / Keystone Div. Penwalt Corp.	Carter EP 150	Carter EP 220	Carter EP 320

▲ Minimum viscosity index of 90.

♦ Kinematic viscosity in units of mm²/s is equivalent to cSt (centistokes).

TABLE 6B — Petroleum Based Micropitting Resistant Lubricants ▲
Maximum Operating Temperature of Lubricants 200°F (93°C)

ISO Viscosity Grade	150	220	320
AGMA Viscosity Grade	4	5	6
Viscosity cSt @ 40°C ♦	135-165	198-242	288-352
Viscosity SSU @ 100°F	626-765	918-1122	1335-1632
Manufacturer	Lubricant Name	Lubricant Name	Lubricant Name
Kluber Lubrication	---	Kluberoil GEM 1 N 220	Kluberoil GEM 1 N 320

▲ Minimum viscosity index of 90.

♦ Kinematic viscosity in units of mm²/s is equivalent to cSt (centistokes).

TABLE 7A — Synthetic PAO (Polyalphaolefin) EP (Extreme Pressure) Lubricants ▲
 Maximum Operating Temperature of Lubricants 200°F (93°C)

ISO Viscosity Grade	32	68	150	220	320
AGMA Viscosity Grade	0	2	4	5	6
Viscosity cSt @ 40°C ■	28.8-35.2	61.2-74.8	135-165	198-242	288-352
Viscosity SSU @ 100°F	134-164	284-347	626-765	918-1122	1335-1632
Manufacturer	Lubricant Name	Lubricant Name	Lubricant Name	Lubricant Name	Lubricant Name
Castrol Industrial Lubricants	---	---	Alphasyn EP 150 Castrol Isolube EP 150	Alphasyn EP 220 Castrol Isolube EP 220	Alphasyn EP 320 Castrol Isolube EP 320
Chevron / Texaco / Caltex	---	---	Tegra Synthetic Gear Lubricant 150	Tegra Synthetic Gear Lubricant 220	Tegra Synthetic Gear Lubricant 320
Citgo Petroleum Corp.	---	CITGEAR Synthetic EP Gear 68	CITGEAR Synthetic EP Gear 150	CITGEAR Synthetic EP Gear 220	CITGEAR Synthetic EP Gear 320
Exxon Mobil / Esso	---	---	Mobil SHC Gear 150	Mobil SHC Gear 220	Mobil SHC Gear 320
Fuchs Lubricants Company	---	---	---	Renolin Unisyn CLP 220	Renolin Unisyn CLP 320
Kluber Lubrication	---	---	Klubersynth EG 4 150	Klubersynth EG 4 220	Klubersynth EG 4 320
Petro-Canada Lubricants	---	---	Enduralex Synthetic EP 150	Enduralex Synthetic EP 220	Enduralex Synthetic EP 320
Phillips 66 / Conoco / 76 Lubricants / Kendall	---	---	Syncon EP Plus Gear Oil 150	Syncon EP Plus Gear Oil 220	Syncon EP Plus Gear Oil 320
Shell Oil Co.	---	Omala S4 GX 68	Omala S4 GX 150	Omala S4 GX 220	Omala S4 GX 320
Whitmore Manufacturing Co.	---	---	Decathlon HD 150	Decathlon HD 220	Decathlon HD 320

▲ Minimum viscosity index of 130. Consult lubricant supplier/manufacturer for maximum operating temperature.

■ Kinematic viscosity in units of mm²/s is equivalent to cSt (centistokes).

TABLE 7B — Synthetic PAO (Polyalphaolefin) Micropitting Resistant Lubricants ▲
 Maximum Operating Temperature of Lubricants 200°F (93°C)

ISO Viscosity Grade	32	68	150	220	320
AGMA Viscosity Grade	0	2	4	5	6
Viscosity cSt @ 40°C ■	28.8-35.2	61.2-74.8	135-165	198-242	288-352
Viscosity SSU @ 100°F	134-164	284-347	626-765	918-1122	1335-1632
Manufacturer	Lubricant Name	Lubricant Name	Lubricant Name	Lubricant Name	Lubricant Name
Chevron / Texaco / Caltex	---	---	---	---	Pinnacle WM 320
Exxon Mobil / Esso	---	---	---	---	Mobil SHC Gear 320 WT
Kluber Lubrication	---	---	Klubersynth GEM 4 N 150	Klubersynth GEM 4 N 220	Klubersynth GEM 4 N 320
Petro-Canada Lubricants	---	---	---	---	Harnex 320
Phillips 66 / Conoco / 76 Lubricants / Kendall	---	---	---	---	Syncon WTL 320
Whitmore Manufacturing Co.	---	---	Decathlon F 150	Decathlon F 220	Decathlon F 320

▲ Minimum viscosity index of 130. Consult lubricant supplier/manufacturer for maximum operating temperature.

■ Kinematic viscosity in units of mm²/s is equivalent to cSt (centistokes).

**TABLE 8 — Conventional Grease ▲ for Grease
Lubricated Bearings & Grease
Purged Seals**

0° to +200°F (-18° to +93°C)

Manufacturer	Lubricant
Chevron / Texaco / Caltex	Multifak EP 2
Citgo Petroleum Corp.	Lithoplex RT 2 Premium Lithium EP 2
ExxonMobil / Esso	Mobilux EP 2
Petro-Canada Lubricants	Precision General Purpose EP2
Phillips 66 / Conoco / 76 Lubri- cants / Kendall	Multiplex Red
Shell Oil Co.	Gadus S2 V100 - 2
Total Lubricants USA / Keystone Div. Penwalt Corp.	Multis 2 or Multis EP 2

▲ Not suitable for food grade applications.

Grease application or re-lubrication should be done at temperatures above 20°F. If grease must be applied below 20° F consult factory or lubricant supplier for recommendations.

FOOD GRADE LUBRICANTS

Guidance for selecting petroleum-based and synthetic-based food grade lubricants are shown below in Table 9. For general lubrication guideline, refer to the first part of the “Lubrication Recommendation” section.

FOOD GRADE LUBRICANT SELECTION PROCESS

1. Refer to Table 10 and 11 for proper lubricant viscosity grade based on ambient temperature range.
2. Refer to Table 9 for summary of lubricant types.
3. Using proper lubricant table and viscosity grade, select desired lubricant manufacturer and name.
4. Refer to Table 3 for approximate oil capacity to purchase.

TABLE 9 — Summary of Food Grade Lubricants and Greases

Petroleum-Based
Extreme Pressure (EP) See Table 12
Synthetic Lubricant, Polyalphaolefin Type (PAO)
Extreme Pressure (EP) See Table 13
Food Grade Grease
See Table 14

FOOD GRADE LUBRICANTS (TABLES 12, 13 & 14) — Food grade lubricants are a class of lubricants registered as H1 by NSF (National Sanitation Foundation). They contain base stock and additives which comply with Food and Drug Administration Title 21 CFR 178.3570 regulations for lubricants with incidental food contact. Base stock can be petroleum oil or different types of synthetic lubricant. Food grade lubricants are not the same as biodegradable or environmentally friendly lubricants.

Rust and corrosion inhibitors used to protect gear drive during shipment are not qualified as food grade fluids. Flush out inhibitor oil before filling with food grade lubricant.

Tables 12, 13 and 14 list food grade lubricants that have performance properties meeting Rexnord specifications. They are not exclusive recommendations but serve as a guide for making proper lubricant selections.

CLIMATE CONDITIONS — Ambient temperature in immediate vicinity of gear drive is very important for determining viscosity grade. Table 10 provides viscosity grade selections for petroleum-based lubricants. See Table 11 for synthetic lubricants.

LUBRICANT CHANGES

OIL ANALYSIS REPORT — Checking oil conditions at regular intervals is recommended. Sample oil for analysis approximately every 1,000 hours for petroleum food grade lubricants or every 3,000 hours for synthetic food grade lubricants. In the absence of more specific limits, the guidelines listed below may be used to indicate when to change petroleum or polyalphaolefin type synthetic food grade lubricants:

1. Water content is greater than 500 ppm (parts per million) (0.05%).
2. Iron content exceeds 150 ppm.
3. Silicon (dust/dirt) exceeds 25 ppm, above reference sample from new oil container.
4. Copper content exceeds 75 ppm.
5. TAN (Total Acid Number) 50% increase above reference sample from new oil container.
6. Viscosity changes more than ±15%.
7. Solid particle contamination code exceeds 25/22/18 for particle sizes ≥4/≥6/≥14 microns, respectively per ISO 4406.

Laboratory analysis is recommended for optimum lubricant life and gear drive performance. Oil samples should be taken from the oil level hole, not the drain hole.

PETROLEUM LUBRICANTS (FOOD GRADE) — In the absence of oil analysis, change gear oils every 6 months or 2,500 operating hours, whichever occurs first. Change oil more frequently when gear drives operate in extremely humid, chemical, or dust laden atmospheres. In these cases, lubricants should be changed every 3 to 4 months or 1,500 to 2,000 hours. If the drive is operated in an area where temperatures vary with the seasons, change the oil viscosity grade to suit the temperature, refer to Table 10. Lubricant suppliers can test oil from the drive periodically and recommend economical change schedules.

SYNTHETIC LUBRICANTS (FOOD GRADE) — In the absence of oil analysis, synthetic lube change intervals can be extended to 8,000 hours depending upon operating temperatures. Laboratory analysis is recommended for optimum lubricant life and drive performance. Change lube with change in ambient temperature, if required. Refer to Table 11.

TABLE 10 — Viscosity Grade Recommendation for Food Grade Petroleum-Based Lubricants

OUTPUT SPEED	AMBIENT TEMPERATURES			
	+15° to +60°F (-9° to +16°C)		+50° to +125°F (+10° to +52°C)	
	ISO-VG	AGMA	ISO-VG	AGMA
RPM BELOW 20	150	4	320	6
20 RPM And ABOVE	150	4	220	5

GREASE PURGED SEALS

Whenever changing oil in the drive, purge the seals with one of the NLGI #2 grade greases listed in Table 14. Purge the contaminated grease from seals by slowly pumping fresh bearing grease through the seal, **WITH HAND GREASE GUN**, until fresh grease flows out along the shaft. Wipe off purged grease.

CAUTION: Rapid regreasing with a power grease gun can force grease inward past the seals and plug the oil drain back system causing seal leaks.

TABLE 11 — Viscosity Grade Recommendation for Food Grade Synthetic Lubricants

Ambient Temperature Range	Cold Climates				Normal Climates			
	-30° to +10°F (-34° to -12°C)		-15° to +50°F (-26° to -10°C)		0° to +80°F (-18° to +27°C)		+10° to +125°F (-12° to -52°C)	
	ISO-VG	AGMA	ISO-VG	AGMA	ISO-VG	AGMA	ISO-VG	AGMA
RPM BELOW 20	32	0	68	2	150	4	320	6
20 RPM And ABOVE	32	0	68	2	150	4	220	5

TABLE 12 — Food Grade Petroleum-Based EP (Extreme Pressure) Type Lubricants – NSF (National Sanitation Foundation) H1 Registered
 Maximum Operating Temperature of Lubricants 200°F (93°C)

ISO Viscosity Grade	150	220	320
AGMA Viscosity Grade	4	5	6
Viscosity cSt @ 40°C ▲	135-165	198-242	288-352
Viscosity SSU @ 100°F	626-765	918-1122	1335-1632
Manufacturer	Lubricant Name	Lubricant Name	Lubricant Name
Petro-Canada	Purity FG EP 150	Purity FG EP 220	Purity FG EP 320
Total Lubricants USA, Inc.	Nevastane EP 150	Nevastane EP 220	Nevastane EP 320

▲ Kinematic viscosity in units of mm²/S is equivalent to cSt (centistokes)

TABLE 13 — Food Grade Synthetic EP (Extreme Pressure) PAO (Polyalphaolefin) Type Lubricants – NSF (National Sanitation Foundation) H1 Registered
 Maximum Operating Temperature of Lubricants 200°F (93°C)

ISO Viscosity Grade	32	68	150	220	320
AGMA Viscosity Grade	0	2	4	5	6
Viscosity cSt @ 40°C ▲	28.8-35.2	61.2-74.8	135-165	198-242	288-352
Viscosity SSU @ 100°F	134-164	284-347	626-765	918-1122	1335-1632
Manufacturer	Lubricant Name	Lubricant Name	Lubricant Name	Lubricant Name	Lubricant Name
Petro-Canada	---	---	---	Purity FG Synthetic EP 220	---

▲ Kinematic viscosity in units of mm²/S is equivalent to cSt (centistokes)

Greases in Table 8 contain harmful substances not allowed in the food processing industry. If grease could contaminate the product, as in the food and drug industries, the grease originally supplied with gear drive must be removed and replaced with grease listed in Table 14. Simply purging grease with grease gun will not remove all grease and cross-contamination will likely occur. Grease registered as H1 by NSF, (National Sanitation Foundation) is suitable for food processing applications.

STORED & INACTIVE GEAR DRIVES

See Storage Procedures (Section VII).

WARNING: Rust preventative oil or vapor-phase inhibitors are not H1 registered with the NSF (National Sanitation Foundation) as suitable for food processing applications. When Food Grade Lubricants are to be used, it is the end users responsibility to properly flush and prepare the drive for Food Grade service. Contact the lubricant manufacturer for specific information and flushing procedures.

TABLE 14 — Food Grade Grease for Grease Purged Seals NSF (National Sanitation Foundation) H1 Registered
 0° to 200°F (-18° to +93°C)

Manufacturer	Lubricant
Bel-Ray Company, Inc.	No-Tox HD Grease 2
Chevron USA, Inc. (Texaco/Caltex)	Chevron FM ALC EP 2
Exxon Mobil	Mobil SHC Polyrex 462
Kluber Lubrication	Klubersynth UH1 14-222
Lubriplate	Lubriplate FGL-2
Total Lubricants USA, Inc.	Nevastane HT/AW 2
Petro-Canada	Purity FG
Phillips 66 / Conoco / 76 Lubricants / Kendall	Food Machinery Grease 2

Grease application or re-lubrication should be done at temperatures above 20°F (-7°C). If grease must be applied at cooler temperatures consult lubricant supplier for recommendations.

Section IV — Start-up

WARNING: Never operate the speed reducer at speeds and/or loads that exceed the limits specified on the nameplate. Exceeding these limits may result in personal injury or machinery damage. Check to insure that all rotating equipment is properly guarded according to OSHA standards.

CAUTION: All speed reducers are shipped without oil but may have been treated with a rust preventative oil. A vapor phase inhibitor may also be added. Be sure to fill the unit to the proper level prior to start-up.

Warning: These corrosion inhibitors are not H1 registered with the NSF (National Sanitation Foundation) as suitable for food processing applications. When Food Grade Lubricants are to be used it is the end users responsibility to properly flush and prepare the drive for Food Grade service. Contact the lubricant manufacturer for specific information and flushing procedures.

CAUTION: When starting up new equipment, proceed cautiously.

4.1 PRE START-UP CHECKLIST

- ① Has the reducer been filled with the proper oil type and to the correct oil level?
- ② Are all mounting bolts high strength ANSI 818.2.1 Grade 5 or ISO 898/1 Grade 8.8 and tightened according to torque specifications in Table 16 (Page 24)?
- ③ Are all input and output shaft couplings, sprockets, pinions, etc. mounted with full engagement and keys in place?
- ④ Have couplings and reducer seals been properly greased?
- ⑤ Are coupling connections properly aligned and fastened?
- ⑥ Have all pipe plugs (oil fill, oil level, and oil drain) been inserted and properly tightened?
- ⑦ Have all electrical connections been made?
- ⑧ Does the motor shaft rotate in the proper direction?
- ⑨ Are all guards in place and properly secured?

4.2 INITIAL START-UP

It is recommended that all Planetgear 7000 speed reducers be run-in for a period of time before introduction to full service. This will allow the gearing to mate properly prior to being exposed to any high load conditions. The following procedure is recommended for initial start-up.

4.2.1 PRIME MOVER

The prime mover should be set up to maximize the amount of time necessary to get to the rated speed. This will avoid any instantaneous gear loads that could exceed the rating of the speed reducer or other components.

4.2.2 REDUCER ROTATION

If the reducer is equipped with an internal backstop, an arrow located on the top of the maincase will indicate the direction of rotation during operation. Make sure the motor shaft will rotate in that direction. If necessary, reverse the leads on the motor so that the proper motor direction is attained.

4.2.3 START-UP

Start the reducer under as light a load as possible. As the unit is brought up to normal operating speed, check for unusual noises, excessive vibration, or excessive heat and oil leakage. If any of these conditions exist, shut down the unit immediately and determine the cause of the problem. Refer to Section 8.0 Troubleshooting (Page 23) for assistance.

4.3 POST START-UP CHECKLIST

- ① After approximately forty hours of use, check all foundation and mounting bolts and tighten as required. Note: Always recheck alignment after tightening.
- ② The oil used in the initial start-up of a new reducer should be completely drained and replaced after 500 hours of use. A thorough cleaning of the gear case using a flushing oil should be performed to remove any foreign matter during the first oil change.

Section V — Maintenance

WARNING: DO NOT PERFORM ANY MAINTENANCE PROCEDURES WHILE REDUCER IS IN OPERATION. DOING SO MAY RESULT IN PERSONAL INJURY OR PROPERTY DAMAGE. TO INSURE SAFETY DURING MAINTENANCE, ACTIVATE ALL ELECTRICAL AND/OR MECHANICAL LOCKOUTS.

5.1 FILLING OIL

1. Choose correct oil type (reference Section 3.0).
2. Determine correct oil quantity (reference Nameplate or Section 3.0).

NOTE: Special applications may have different oil quantity requirements. Refer to the nameplate for specific oil quantity.

3. Remove oil fill plug (vent plug) and one of the two oil level plugs; reference Figure 5.1.

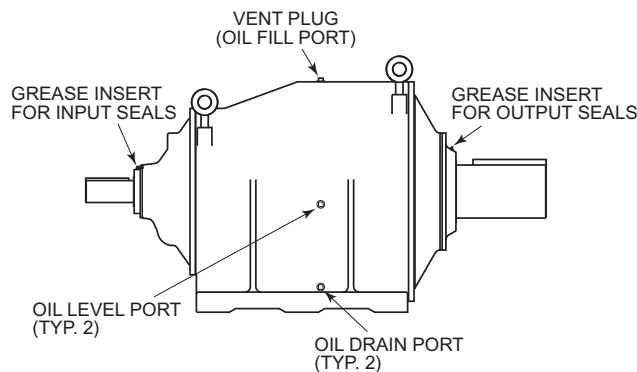

Figure 5.1 Reducer Oil Ports, Vent Plug and Grease Insert Locations

4. Fill reducer at oil fill port.
5. Reducer oil capacity is reached when oil starts to pour out of the bottom of the oil level port. Allow several minutes for oil to settle, then recheck oil level. Add oil if necessary.

NOTE: Oil should be checked or added when reducer is at ambient temperature.

CAUTION: Underfilling reducer may cause product damage. Overfilling reducer may cause excessive oil temperatures.

6. Replace oil level plug, sealing it in the process using thread sealant.
7. Replace oil fill plug, sealing it in the process using thread sealant.
8. Start up reducer under a no load condition. Run reducer for a few minutes.
9. Stop reducer and recheck oil at the oil level port. If necessary, add oil.

5.2 DRAINING OIL

1. Clean external surfaces to avoid contaminants from entering unit when plugs are removed.
2. Remove oil fill plug (vent plug) for ventilation (reference Figure 5.1).

CAUTION: Care should be taken when removing the oil fill plug. The possibility of pressurized air inside the reducer may exist. Once threads are free to hand rotate, place a heavy cloth over the plug and rotate counterclockwise until removed.

3. With the proper size oil drain pan (reference oil quantity on nameplate) in place, remove the drain plug.

CAUTION: Oil may be hot. Do not drain until oil is at ambient or a safe temperature.

4. After oil is removed, replace oil drain plug, sealing it in the process using thread sealant.
5. Reference Section 5.1 for filling reducer with oil.

5.3 ADDING GREASE TO REDUCER SEALS

1. Clean grease inserts, reference Figure 5.1 for location.
2. Refer to the Lubrication section to determine the correct grease for the application. Attach grease gun to grease insert and pump grease into seal carrier.
3. Stop greasing when a sufficient amount of grease purges out of seal carrier next to shaft.

NOTE: Grease should purge from outboard seal onto shaft, if this does not occur, refer to Section 6.2 to check for proper seal installation.

4. Clean purged grease from reducer.

5.4 REPLACING SEALS IN SERVICE Reference Section 6.2 for procedure.

Section VI —Disassembly and Assembly Instructions

The following instructions are for the Jupiter Plus speed reducer. This is a guide for disassembly, parts replacement, and reassembly. Note, the drawings used are not to scale and therefore may not agree in every detail. To expedite service, when ordering parts or requesting information, supply the following information: model number, reducer size, ratio, serial number, HP, motor RPM, and the build date from the reducer nameplate. No ratio change should be made without first consulting a Planetgear 7000 representative. All bearings and seals used on standard Planetgear 7000 speed reducers are listed in Table 17 and Table 18 (Page 25).

REQUIRED EQUIPMENT

Standard mechanic's tools: arbor press or hydraulic press, torque wrench, dial indicator with magnetic base, and hoist.

CAUTION: Always take the necessary safety precautions when working with an arbor press, hydraulic press or with any hand tools.

6.1 TAKING REDUCER OUT OF SERVICE

NOTE: If only replacing seals, the reducer need not be pulled from service.

1. Disconnect all attached equipment.

WARNING: Do not perform any maintenance procedures while reducer is in operation. Doing so may result in personal injury or property damage. To insure safety during maintenance, activate all electrical and/or mechanical lockouts.

2. Remove all reducer mounting bolts.
3. Lift reducer as explained in Section 2.1.
4. Drain oil from reducer, reference Section 5.2 for procedure.

NOTE: Care should be taken to protect the shafts from damage. Damaged shaft may cause problems when reinstalling couplings, sprockets, or sheaves.

6.2 REPLACING SEALS

6.2.1 REMOVING SEALS CARRIER

NOTE: If only replacing seals, the reducer need not be pulled from service. Seals are housed in a seal carrier which can be removed from the reducer at the installation location.

NOTE: If unit is equipped with a fan and shroud, remove fan and shroud.

NOTE: If working with a Venus/Atlas/Luna quadruple reduction or Earth/Polaris/Delta quintuple reduction, high speed seals are to be replaced as instructed in Replacing Seals Section of the Mercury & Mars Owners Manual.

1. Clean shaft extension.
2. Drain oil from reducer before removing seal carrier; reference Section 5.2.
3. Remove bolts attaching seal carrier to input or output housing (Note location of grease fitting for reinstallation).
4. Using a flat blade and a hammer, break the seal between the seal carrier assembly and the input or output housing; reference Figure 6.2.1.

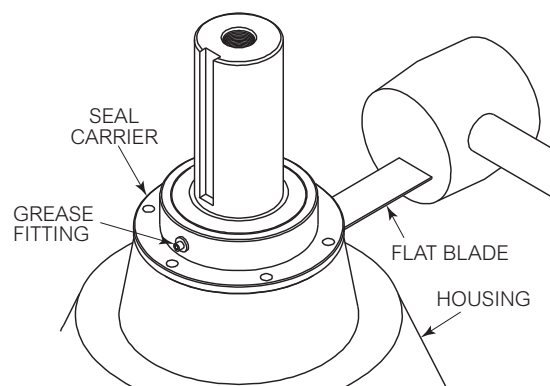

Figure 6.2.1 Separation of Seal Carrier from Hub

5. Remove seal carrier.
6. After seal carrier is removed, protect the input or output bearings from contamination by wrapping a clean cloth (or equivalent) around the exposed area.

CAUTION: When removing seal carrier, care should be taken not to damage or contaminate the bearings. Damaged bearings may reduce bearing life.

6.2.2 REMOVING SEALS FROM SEAL CARRIER

1. Remove seal carrier from the input or output housing; reference Section 6.2.1 Removing Seal Carrier.
2. With a set of blocks or equivalent, support the seal carrier up so the seals can be pushed out; reference Figure 6.2.2, next page.
3. With an arbor press or a hydraulic press, carefully push seals out of seal carrier using a metal tube or a circular disc.

NOTE: Take care not to scratch or gouge the inside diameter of the seal carrier or the surface that mates to the input or output housing. Damage to these areas may result in oil leakage during operation.

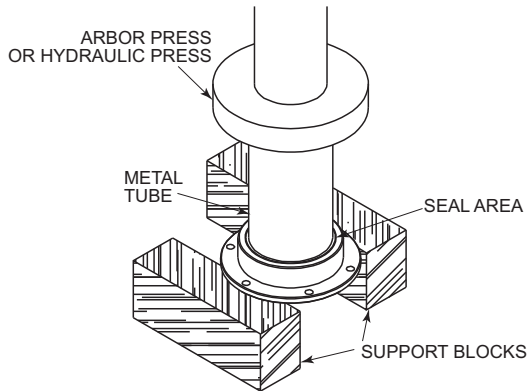

Figure 6.2.2 Removal of Seals from Seal Carrier

6.2.3 INSTALLING NEW SEALS

1. Remove seal carrier from the input or output housing; reference Section 6.2.1.
2. Remove seals from seal carrier; reference Section 6.2.2.
3. Clean all machined surfaces on the seal carrier and the machined surface that the seal carrier seats to on the input or output housing.
4. Place seal carrier outboard side face down on a flat surface. Set the double lipped seal on seal carrier so that the opening (garter spring side) faces the inboard side; reference Figure 6.2.3.1A.

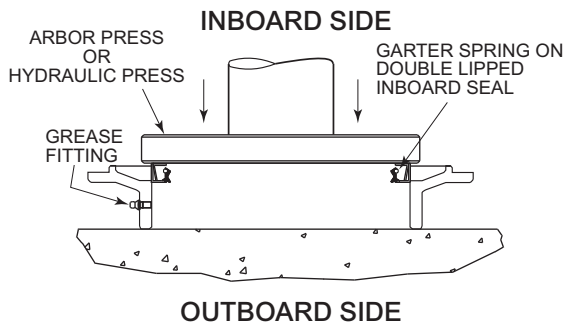

Figure 6.2.3.1A Placement of Inboard Seal for Installation

5. With an arbor press or a hydraulic press, carefully push seal into seal carrier flush with end of chamfer; reference Figure 6.2.3.1B, next column.

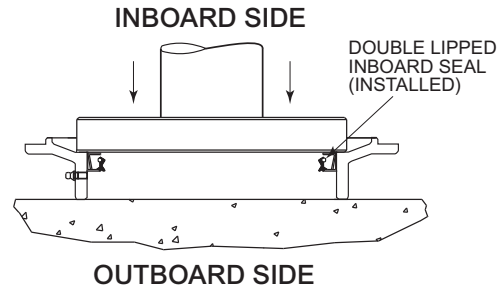

Figure 6.2.3.1B Installation of Inboard Seal

NOTE: Be sure to push seal in squarely. Any misalignment might damage seal and result in oil leakage.

6. Place seal carrier inboard side face down on a flat surface. Set the single lipped seal on the seal carrier so that the opening (garter spring side) faces the outboard side; reference Figure 6.2.3.2A.

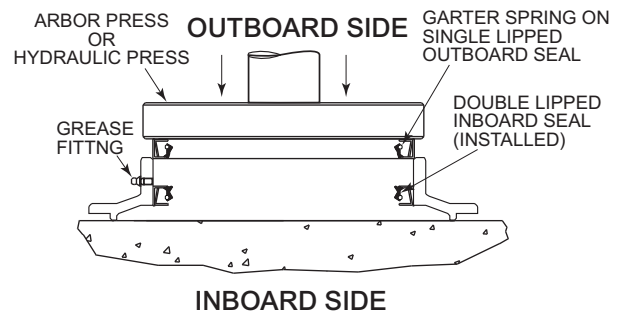

Figure 6.2.3.2A Placement of Outboard Seal for Installation

7. With an arbor press or a hydraulic press, carefully push seal into seal carrier until the seal seats flush to the outboard face of the seal carrier; reference Figure 6.2.3.2B.

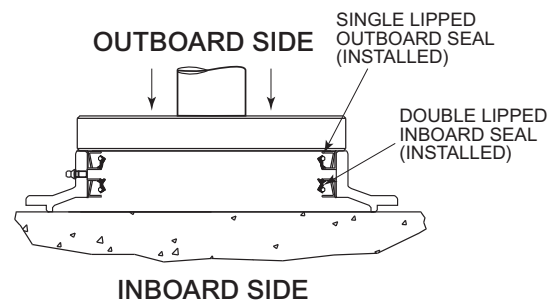

Figure 6.2.3.2B Installation of Outboard Seal

NOTE: Be sure to push seal in squarely. Any misalignment might damage seal and result in oil leakage.

6.2.4 INSTALLING SEAL CARRIER - INPUT/OUTPUT SHAFT ASSEMBLY

1. Clean the machined surfaces where the seal carrier and the input or output housing mate.

NOTE: Scraping of surfaces with a putty knife may be required.
2. Apply a bead of sealant around the inboard lip of the seal carrier and/ or around the face of the input or output housing inside the bolt hole circle.

NOTE: Use Loctite 515 gasket eliminator, or equivalent as a sealant.
3. Slip the seal carrier over the shaft.

CAUTION: Extreme care must be taken to not roll the lip of the seal or cut the seal on the keyway.
4. When the seal carrier is piloted on the shaft pilot, seat the seal carrier by slowly pressing down on the flange; reference Figure 6.2.4.

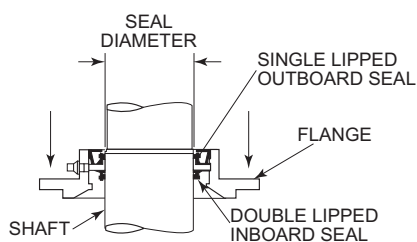

Figure 6.2.4 Placement of Seal Carrier Assembly onto Shaft

NOTE: Orientate the seal carrier grease fitting to the position best suited to your application. Reducers are assembled at the Factory with the grease fitting oriented in-line with an oil port in the input or output shaft housings and are normally in the 12 o'clock position.

5. Bolt seal carrier to input or output housing, reference Table 16 (Page 24) for bolt torques.
6. Add grease to seal carrier; reference Section 5.3.
7. Add oil to reducer; reference Section 5.1.

6.3 REPLACING BEARINGS - INPUT/OUTPUT SHAFT ASSEMBLIES

6.3.1 REMOVING INPUT OR OUTPUT SHAFT ASSEMBLIES TO REPLACE BEARINGS

1. Take reducer out of service; reference Section 6.1.
2. Clean all external surfaces to prevent contaminants from entering unit when disassembled.
3. Drain oil from unit; reference Section 5.2.
4. If unit is equipped with a fan and shroud, remove fan and shroud.

NOTE: For better results, mount reducer in the vertical position; reference Steps A, B, and C.

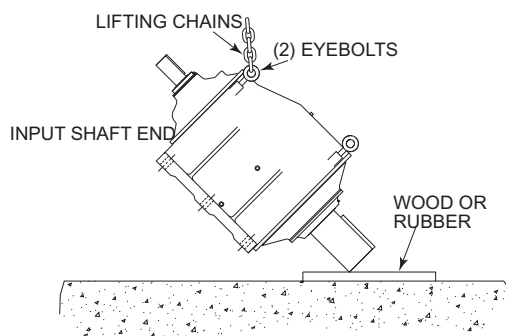

Step A — Carefully lift reducer by using the two eyebolts located on the input shaft end of reducer. Do not allow output shaft to be damaged.

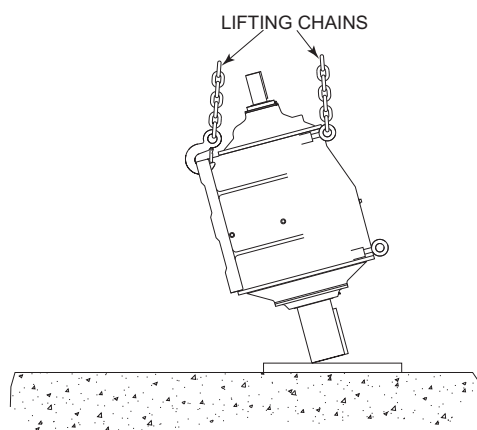

Step B — Carefully lift reducer to vertical position by both the two eyebolts and the two foot mounting holes on the input shaft end..

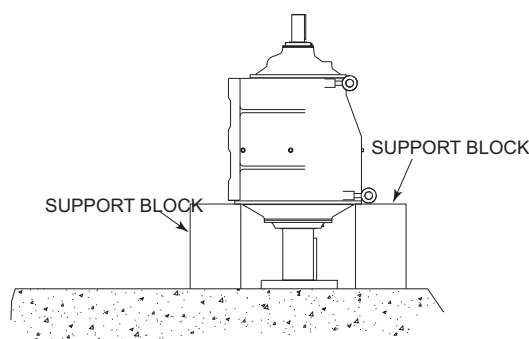

Step C — Carefully place reducer in vertical position on support blocks.

NOTE: Special care should be taken when removing the output assembly. All gearing is stabilized at the output assembly. Removing output assembly first may result in difficulties during reducer reassembly. It is recommended that the input assembly be removed first, then the gear train, and finally the output assembly (reference Section 6.5 for additional information).

5. Remove the bolts that attach the assembly to the maincase.
6. With a 1/2" bolt, drive the bolt into one of the three 1/2-13 UNC threaded holes. This will break the seal between the housing and the maincase allowing the removal of the assembly.
7. Remove assembly by lifting it straight up away from the maincase. An eye bolt can be used in the threaded end of the shaft to lift the assembly; reference Figure 6.3.1. **DO NOT LIFT ENTIRE REDUCER BY THE THREADED HOLE ON EITHER SHAFT.**

CAUTION: Do not lift input or output shaft assembly by hand. The assemblies are heavy and lifting by hand can cause serious injury.

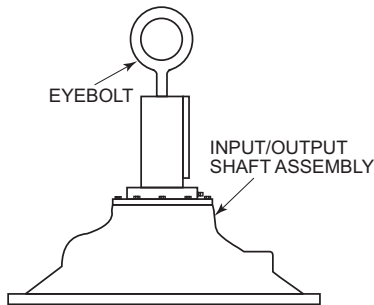

Figure 6.3.1 Proper Lifting of Input or Output Shaft Assemblies

NOTE: Place all removed parts on a clean dry surface to avoid contact with contaminants.

6.3.2 DISASSEMBLING INPUT OR OUTPUT SHAFT ASSEMBLIES TO REPLACE BEARINGS

1. Remove endbell from reducer; reference Section 6.3.1.
2. Remove seal carrier from endbell; reference Section 6.2.1.
3. Support hub to expose the inboard side of the endbell; reference Figure 6.3.2.1.

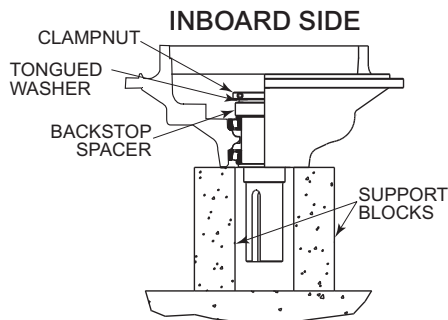

Figure 6.3.2.1 Endbell Disassembly

NOTE: Allow space between the shaft extension and the working surface.

4. **OUTPUT ONLY** – Remove external retaining ring. Store in clean spot.
5. Loosen socket head cap screw on clampnut.

6. Remove clampnut from shaft. Store in clean spot. **NOTE:** A wedge can be used to spread the clampnut in order to ease removal.
7. Remove tongued washer from shaft. Store in clean spot.
8. **INPUT ONLY** - Remove backstop or backstop spacer from shaft. Store in clean spot.
9. With an arbor press or a hydraulic press, press on the inboard end of the shaft to break free the inboard bearing cone.
10. At this time, the shaft will be free and can be separated from the housing. The inboard bearing cone will be free to remove and discard.

CAUTION: The input and output shafts are heavy.

11. To remove the outboard bearing from the shaft, one of two procedures can be used. 1.) Support the shaft by the bearing cone with the inboard end of the shaft facing up. With an arbor press or hydraulic press, press down on the inboard end of the shaft; reference Figure 6.3.2.2. 2.) With a hammer and punch, carefully strike the bearing cone towards the inboard end of the shaft; reference Figure 6.3.2.3, below.

NOTE: Take care not to damage the shaft bearing surface or seal surface.

12. With a hammer and punch, tap out the inboard and outboard bearing cups from the housing.

NOTE: Take care not to damage the bearing surface of the housing.

INBOARD END OF SHAFT

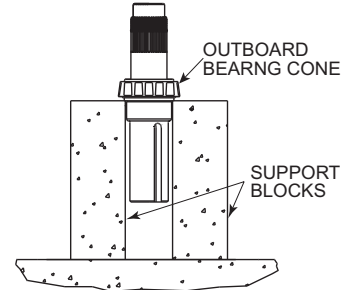

Figure 6.3.2.2 Removal of Outboard Bearing Cone (Option #1)

OUTBOARD END OF SHAFT

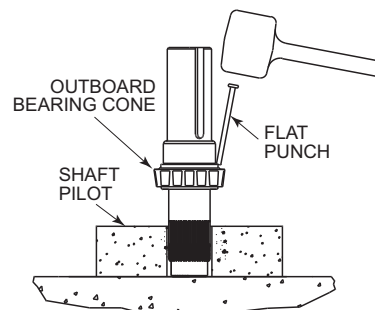

Figure 6.3.2.3 Removal of Outboard Bearing Cone (Option #2)

6.3.3 INSTALLING BEARING CUPS INTO INPUT OR OUTPUT HOUSINGS

1. Clean machined surfaces on housing where bearing cups are located.
NOTE: If high spots or burrs occurs after disassembly, use discretion to remove them. Bearing cup has to be seated perfectly to insure proper bearing alignment.
2. Place bearing cup squarely on the bearing bore. With an arbor press or a hydraulic press and flat disc push bearing cup into housing until seated.
NOTE: This procedure applies to both inboard and outboard bearing cup. Be sure to push cups in evenly. Any misalignment may result in a damaged housing or bearing cup.
NOTE: Take care not to scratch or gauge bearing surface. Any damage done may result in premature damage of the bearings.
3. With a 0.001" or 0.040 mm feeler gage, make sure that there is no gap between the housing and the bearing cups to insure proper cup seating; reference Figure 6.3.3.

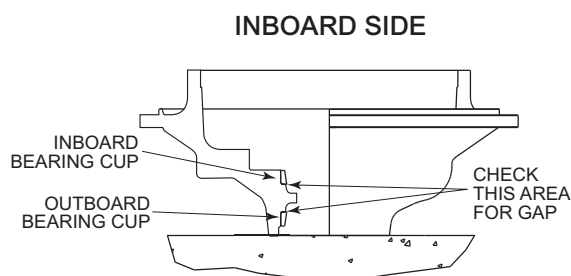

Figure 6.3.3 Installation of Inboard and Outboard Bearing Cups

NOTE: Any gap between hub and bearing cups can result in excessive axial bearing clearance or bearing misalignment and ultimately result in premature bearing damage.

6.3.4 ASSEMBLING INPUT OR OUTPUT SHAFT ASSEMBLIES

1. Clean bearing surface on shaft.
2. Make sure bearing cups are clean and installed properly in housing; reference Section 6.3.3.
3. Set shaft on end with the spline end of the shaft facing up.

CAUTION: Assembly may become top heavy. Pilot assembly so that it will not fall over.

4. Place the outboard bearing cone squarely on the inboard end of the shaft with the smaller diameter of the bearing facing inboard; reference Figure 6.3.4.1.

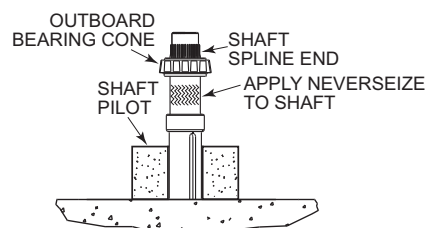

NOTE: DO NOT APPLY NEVERSEIZE TO THREADS

Figure 6.3.4.1 Installation of Inboard and Outboard Bearing Cups

NOTE: For output assembly, the use of Neverseize around the shaft is allowed to ease assembly. DO NOT put Nerverseize on threaded part of shaft.

5. With an arbor press or a hydraulic press carefully push bearing cone until it bottoms on shaft shoulder.

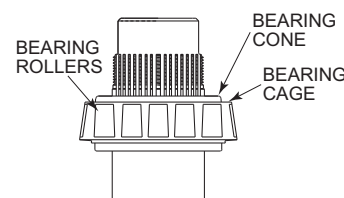

Figure 6.3.4.2 Location of Bearing Cage and Roller Bearing

NOTE: For output assembly, the use of Neverseize around the shaft is allowed to ease assembly. DO NOT put Neverseize on threaded part of shaft.

6. With a 0.001" or 0.040 mm mm feeler gage, make sure that there is no gap between the shaft shoulder and the bearing cone to insure proper cone seating; reference Figure 6.3.4.3.

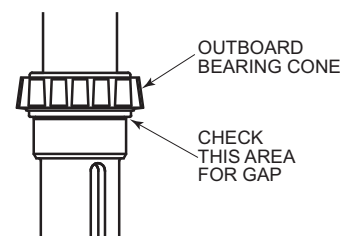

Figure 6.3.4.3 Checking for Zero Clearance with Feeler Gauge

NOTE: Any gap between shaft and bearing cone can result excessive axial bearing clearance or bearing misalignment and ultimately result in premature bearing damage.

7. Carefully set the housing, outboard side face down, onto the outboard bearings.

NOTE: It is helpful to use a crane to lift hub onto shaft; reference Figure 6.3.4.4.

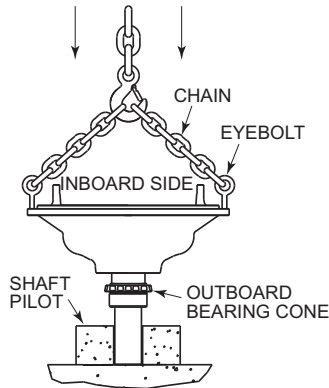

Figure 6.3.4.4 Placing Inboard Bearing Cone onto Shaft

8. While rotating the housing on bearings, apply clean oil to the bearings.
9. Place the inboard bearing cone squarely on the inboard end of the shaft with the smaller diameter of the bearing facing the outboard; reference Figure 6.3.4.5.

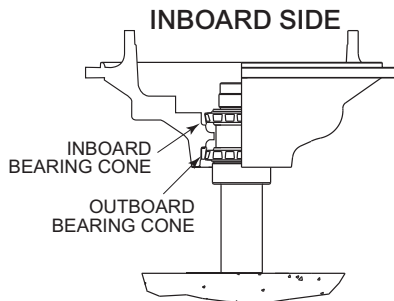

Figure 6.3.4.5 Placing Inboard Bearing Cone onto Shaft

10. With an arbor press or a hydraulic press carefully push bearing cone. When bearings begin to approach the bearing cup, apply clean oil to inboard bearings.

NOTE: DO NOT push on bearing rollers or bearing cage; reference Figure 6.3.4.2.

11. Press inboard bearing until it touches the surface of the bearing cup.

NOTE: Do not over push bearings into cup. This might cause the bearings to Brinell the cup.

NOTE: An indication when the inboard bearing is fully seated is when the hub will not rotate on the shaft freely.

12. **INPUT ONLY** - Clean and place the backstop or backstop spacer onto the shaft.

NOTE: The desired rotation of the reducer is determined by viewing thru the output shaft side. Reference Figure 6.3.4.6 for orientation of the backstop after being assembled onto the input shaft.

13. Clean and place the tongued washer onto the shaft.

14. Clean clampnut. Place it with the grooved side down

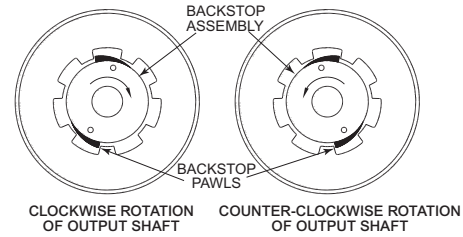

Figure 6.3.4.6 Backstop on Input Assembly

(or groove towards bearings) and thread on clampnut until it is unable to rotate.

15. Mark the location of the clampnut.
16. Loosen clampnut approximately 3/4" (19 mm) from original mark.
17. Tighten socket head cap screw on clampnut; reference Table 6.
18. **OUTPUT ONLY** - Install external retaining ring.
19. Support hub and affix to work table with the shaft not touching the table; reference Figure 6.4.1.
20. With an arbor press or a hydraulic press, push on the inboard end of the shaft to relieve the bearings.

NOTE: A popping noise will sound when bearings are relieved. If the noise does not occur, an alternative way to determine if the bearings have been relieved is if the housing rotates freely on the bearings.
21. Reference Axial Bearing Clearance, Section 6.4 for proper bearing endplay.

6.4 SETTING PROPER AXIAL BEARING CLEARANCES ON INPUT OR OUTPUT SHAFT ASSEMBLIES

6.4.1 MEASURING AXIAL CLEARANCE ON INPUT AND OUTPUT ASSEMBLIES

1. Support housing to allow the shaft to rotate freely; reference Figure 6.4.1.

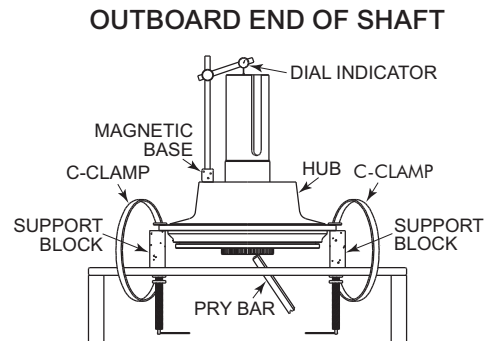

Figure 6.4.1 Setting Axial Bearing Clearance

NOTE: If necessary, the axial bearing clearance can be measured by orientating the larger assemblies outboard side down. The dial indicator should then be placed on the inboard end of the shaft while prying upwards on the outboard end of the shaft.

NOTE: Axial clearance should be checked while seal carrier is removed.

2. Affix the hub to the support table with C-Clamps or bolting to table; reference Figure 6.4.1.
3. While exerting downward force by hand on the end of the shaft, rotate shaft 6 to 10 times to align the bearing rollers.
4. Use a dial indicator with a magnetic base to take measurements.

NOTE: Use a dial indicator that has a balanced dial with 0.0001" or 0.010 mm graduations.
5. Affix the magnetic base of the dial indicator to a flat area of the housing; reference Figure 6.4.1.
6. Place the stem of the dial indicator perpendicular to the end of the shaft.

NOTE: Place stem of dial indicator as close to the center of the shaft as possible.
7. Record the reading of the dial indicator when the indicator has engaged the shaft.
8. With a pry bar, push the inboard end of the shaft up; reference Figure 6.4.1.

NOTE: Use a constant swift force when pushing on the pry bar. Excessive force not required. DO NOT rotate shaft while pushing on shaft. The object is to lift the shaft only.
9. Record reading of the dial indicator. Take the difference between the two readings. The difference is the axial bearing clearance.

NOTE: 0.001" to 0.004" (0.025 to 0.102 mm) axial bearing clearance is recommended. Do steps 3 thru 9 several times to insure an accurate measurement has been made.
10. See Sections 6.4.2 and 6.4.3 for adjusting for too much or too little axial bearing clearance.

6.4.2 ADJUSTING FOR TOO MUCH AXIAL BEARING CLEARANCE

NOTE: If axial bearing clearance is too excessive, it might be necessary to remove the clampnut and other hardware, and press the bearing again. Reference Section 6.3.4 - steps 11 to 20, or Section 6.3.4 - steps 12 to 21.

1. Loosen socket head cap screw on clampnut.
2. Mark the position of the clampnut.
3. Rotate clampnut 1/16" to 1/8" (1.5 to 3.1 mm) in the clockwise direction from mark to tighten clampnut.

NOTE: The measurement given is an estimate.
4. Tighten socket head cap screw on clampnut.
5. Follow procedures in Section 6.4.1 to determine new axial bearing clearance.
6. Repeat first 5 steps if axial bearing clearance is found to be still too much.

6.4.3 ADJUSTING FOR TOO LITTLE AXIAL BEARING CLEARANCE

1. Loosen socket head cap screw on clampnut.
2. Mark the position of the clampnut.
3. Rotate clampnut 1/16" to 1/8" (1.5 to 3.1 mm) in the counter clockwise direction from mark to loosen clampnut.

- NOTE:** The measurement given is an estimate.
4. Tighten socket head cap screw on clampnut.
 5. With an arbor press or hydraulic press, push on the clampnut end of shaft to increase the bearing axial clearance.
 6. Follow procedures in Section 6.4.1 to determine new axial bearing clearance.
 7. Repeat first 6 steps if axial bearing clearance is found to be still too little.

6.5 GEAR TRAIN DISASSEMBLY

Place gears in a clean dry place in the order of disassembly. Exploded view drawings of a specific gear train may be requested from the factory by specifying the reducer serial number, model number, size, ratio, and rating. To order replacement components, please give the previously stated information about the reducer and the items needed. Reference the following sketches for general exploded view drawings.

NOTE: All the gearing is stabilized at the output assembly. Removing output assembly first may result in a difficult time reassembling reducer. It is recommended that the input assembly be removed first, then the gear train, and finally the output assembly.

Double Reduction Disassembly — Remove input assembly (1), input gear (2), maincase (3), ring gear (4), first stage carrier (5), last stage sun gear (6), ring gear (7), last stage carrier (8), and output assembly (9).

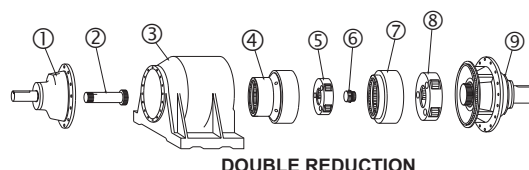

DOUBLE REDUCTION

Triple Reduction Disassembly — Remove input assembly (1), input gear (2), maincase (3), first stage carrier (4), ring gear (5), sun gear (6), second stage carrier (7), last stage sun gear (8), ring gear (9), last stage carrier (10), and output assembly (11).

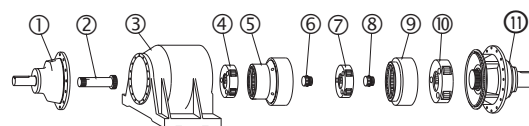

TRIPLE REDUCTION

Quadruple Reduction disassembly — Remove input assembly (1), input gear (2), maincase (3), first stage carrier (4), ring gear (5), sun gear (6), second stage carrier (7), ring gear (8), sun gear (9), third stage carrier (10), last stage sun gear (11), ring gear (12), last stage carrier (13), and output assembly (14).

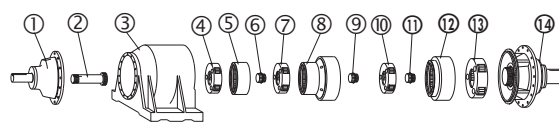

QUADRUPLE REDUCTION

6.6 GEAR TRAIN ASSEMBLY

The gear train can be assembled in the reverse order of disassembly. Reference Section 6.5.

NOTE: It is recommended that the output sub-assembly be installed first, then the gear train, and finally the input sub-assembly. Unit should be assembled in the vertical position, with input shaft up.

6.7 FAN AND SHROUD INSTALLATION

6.7.1 SHROUD CLIP INSTALLATION

Remove mounting bolts from input sub-assembly / maincase in the following locations and install shroud clips; reference Figure 6.7.1A.

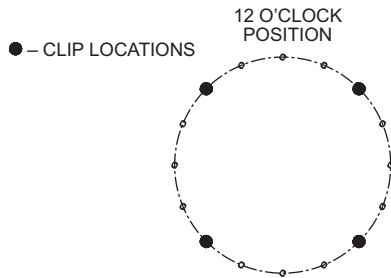

Figure 6.7.1A Location of Shroud Clips

Align shroud clip with center of reducer; reference Figure 6.7.1B, and tighten bolts to torque requirements of Table 16, (Page 24).

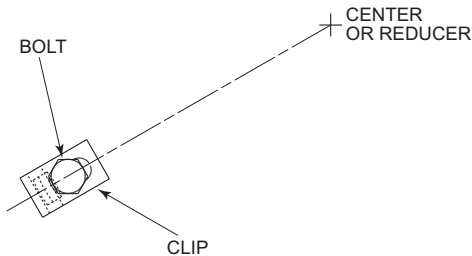

Figure 6.7.1B Location of Shroud Clips

6.7.2 FAN INSTALLATION

From Figure 6.7.2, determine the distance from the end of the input shaft to the front edge of the fan.

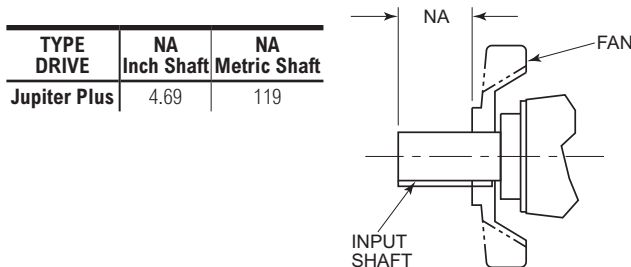
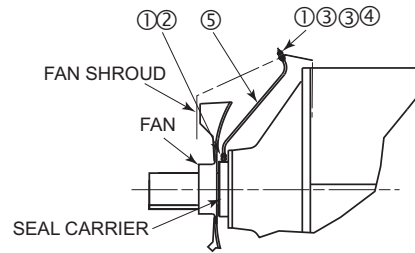

Figure 6.7.2 Location of Fan

With key in place, position the fan on the input shaft to the determined “NA” distance.

Locate the set screw which is 90° from the keyway to the spotting hole on the shaft.

Tighten set screws (2). Reference Table 15, (Page 24) for torque requirements.



ITEM	Description
1	1/8" NPT x 1/4" O.D. TUBE STRAIGHT QD. BRASS FITTING.
2	1/4"-28 MALE x 1/8" NPT FEMALE ADAPTER
3	3/8" STEEL WASHER
4	1/8" NPT GREASE FITTING
5	1/4" O.D. TUBE x 12" LG. (300 mm)

6.7.3 REMOTE GREASE LINE INSTALLATION

Per preceding drawing, install grease fitting hardware (items 1, & 2) at seal carrier (if not already installed) and fill grease tube (item 5). Note, fill grease tube prior to installation.

Assemble grease fitting hardware (items 1 & 2) into pre-drilled 7/16 (11 mm) diameter hole in fan shroud (if not already installed).

The grease line (item 5) will be inserted into the grease fitting hardware in the fan shroud when the shroud is assembled to the speed reducer.

6.7.4 FAN SHROUD INSTALLATION

Position the fan shroud so that it fits tight over the shroud clips. Check to insure that when the input shaft is rotated, the fan does not interfere with the shroud. Gently bend the shroud clips to position the shroud.

NOTE: The fan shroud should be pre-drilled for the shroud clips and the remote grease line (RGL).

Insert RGL grease tube into shroud grease fitting hardware.

Using bolts and washers that were removed originally during disassembly, fasten the shroud to the shroud clips.

Section VII — Storage Procedures

7.1 SPARE PARTS STORAGE

1. On receipt of spare parts, unpack and spray or dip the parts in a rust preventative such as Mobilarma 524, or equivalent.
2. Place parts on a wood pallet in a dry place. Cover loosely with plastic, DO NOT wrap or store parts in news print as it is corrosive.
3. Re-spray parts every six months. Spray parts every three months if high humidity exists.
4. If rust develops, remove rust with a medium grit emery cloth and re-spray with rust preventative.
5. When ready to install parts, make sure all parts rotate freely. Clean all grime from the parts before installation.

7.2 STORED AND INACTIVE REDUCERS

1. Preparation For Storage
 - A. If a reducer is to be stored or is inactive after installation; fill the reducer with the correct type and amount of lubricant. For drives that have oil installed, add Nox-Rust VCI-10 * vapor-phase rust inhibitor at the rate of 2% of sump capacity. For drives without oil, add Nox-Rust VCI-10 vapor-phase rust inhibitor at the rate of one ounce per cubic foot of internal drive space. Seal the reducer completely; replace the vent plug with a solid pipe plug to keep rust inhibiting atmosphere sealed inside.
 - B. After approximately three months, rotate the input shaft such that the output shaft rotates a full 360°. This will insure that all internal parts will remain coated and will also keep the bearings from becoming lacquered. Noncompliance with this procedure may cause bearing damage during start-up.

- C. Every six months inspect the stored or inactive reducer and add Nox-Rust VCI-10 * if necessary. Dry, indoor storage is recommended.

WARNING: Nox-Rust VCI-10 * is not H1 registered with the NSF (National Sanitation Foundation) as suitable for food processing applications. When Food Grade Lubricants are to be used, it is the end users responsibility to properly flush and prepare the drive for Food Grade service. Contact the lubricant manufacturer for specific information and flushing procedures.

* Product of the Daubert Chemical Company, Chicago, Illinois.

2. Preparation For Start-up

Rotate shafts until the bearings move freely. This is to assure that the bearings have not become lacquered. Reducer may be operated without draining the lubricant described in Section 7.2-A.

7.3 LONG TERM STORAGE

Reducer can be ordered from the factory for long term storage. Field preparation for long-term storage is described Section 7.2.

WARNING: The rust preventative oil from the factory and Nox-Rust VCI-10 * are not H1 registered with the NSF (National Sanitation Foundation) as suitable for food processing applications. When Food Grade Lubricants are to be used, it is the end users responsibility to properly flush and prepare the drive for Food Grade service. Contact the lubricant manufacturer for specific information and flushing procedures.

Section VIII — Troubleshooting

This troubleshooting guide addresses questions that may be encountered in regards to Planetgear speed reducers.

EXCESSIVE TEMPERATURE [more than 200°F (93°C)]

POSSIBLE CAUSES:	POSSIBLE SOLUTIONS:
OVERLOAD	<ul style="list-style-type: none"> Compare actual reducer load with rated load on the nameplate. If the HP or torque is greater, or the speed is slower than stated on the nameplate, the reducer is probably overloaded. Contact a Rexnord Planetgear Representative; may require a speed change or a larger unit.
TIGHT OR DEFECTIVE BEARINGS	<ul style="list-style-type: none"> Inspect bearings for excessive wear or discoloration due to heat. If either is present, replace the bearings. Refer to Section 6.0 for replacing bearings.
EXCESSIVE AMBIENT TEMPERATURE	<ul style="list-style-type: none"> Provide ventilation for the reducer. Paint white if reducer is in direct sun light. If conditions are extreme, contact a Rexnord Planetgear Representative for assistance.
IMPROPER OIL, OIL LEVEL, OLD, OR CONTAMINATED OIL	<ul style="list-style-type: none"> Make sure lubricant is correct for reducer. A mistake frequently made is to use automotive oil. This is incorrect and will frequently cause the reducer to overheat. Check the oil level in the reducer. Too much as well as too little oil can cause the reducer to overheat. Check to see that oil has not lost its lubricating property. If oil viscosity is too low, this will result in high oil temperatures.
PLUGGED SHROUD	<ul style="list-style-type: none"> Make sure area immediately in front of fan shroud is clear.
OVERSPEED	<ul style="list-style-type: none"> Reduce input speed to reduce oil temperature. If reducer input speed is above the stated value on the nameplate, this would raise oil temperature due to increase in internal windage.
RESTRICTED VENT PLUG	<ul style="list-style-type: none"> Remove and clean vent plug. Replace vent plug.

BEARING DAMAGE

IMPROPER ADJUSTMENT	<ul style="list-style-type: none"> Adjust bearing to proper axial bearing clearance as instructed in Section 6.0.
LACK OF LUBRICATION, IMPROPER LUBRICATION, OLD, OR CONTAMINATED OIL	<ul style="list-style-type: none"> Replace damaged bearings as instructed in Section 6.0. Note: Check hub and shaft for potential damage or heat distress.
EXCESSIVE OVERHUNG LOAD	<ul style="list-style-type: none"> Reduce overhung load. Move the sprocket or sheave closer to the bearings or increase the diameter of both the driven and the driver

BEARING NOISE

DEFECTIVE BEARING	<ul style="list-style-type: none"> Inspect and replace bearings if necessary. Reference Section 6.0.
IMPROPER BEARING ADJUSTMENT	<ul style="list-style-type: none"> Adjust bearing endplay. Reference Section 6.0.
WRONG OR INSUFFICIENT LUBRICATION	<ul style="list-style-type: none"> Make sure that enough oil of the correct grade is used. Reference Section 3.0.

LEAKAGE

DAMAGED OR WORN SEALS	<ul style="list-style-type: none"> Replace seals. Reference Section 6.0.
BEARINGS OUT OF ADJUSTMENT	<ul style="list-style-type: none"> Reset bearings. Reference Section 6.0.
EXCESSIVE TEMPERATURE, CAUSING BRITTLE SEALS	<ul style="list-style-type: none"> Isolate reducer from source of extreme temperature. Install high temperature seals.
ABRASIVE OR CORROSIVE ATMOSPHERE	<ul style="list-style-type: none"> Isolate reducer seal area from environment. Re-grease frequently.
RESTRICTED VENT PLUG	<ul style="list-style-type: none"> Remove and clean vent plug. Replace vent plug.
SPLIT-LINE LEAKAGE	<ul style="list-style-type: none"> Make sure fasteners are torqued correctly. Reference Table 16. Remove suspect hub. Visually inspect mating surfaces for rises or dings. File smooth (do not allow file shavings to enter gearing or bearings) apply gasket eliminator and replace hub.

DAMAGE OF FASTENERS

FAILURE OF FASTENERS	<ul style="list-style-type: none"> Make sure fasteners are torqued correctly. Reference Table 16. Make sure the correct grade of fastener is used. All reducer fasteners should be ANSI B18.2.1 Grade 5 or ISO 898/1 Grade 8.8 or greater. Check length of fastener.
FASTENER LOOSENING	<ul style="list-style-type: none"> Make sure fasteners are torqued correctly. Reference Table 16. For highly vibratory environments, loctite fasteners and torque, or use studs and double nut.



Section IX — Tables

TABLE 15 — Average Weights – lb (kg)

REDUCER SERIES	Reducer Only				Slide Base Only	Baseplate Only	Scoop Mount 1 Only		Scoop Mount 2 Only	
	Double	Triple	Quadruple	Quintuple			Double, Triple, Quadruple	Quintuple	Double, Triple, Quadruple	Quintuple
Jupiter Plus	3329 (1510)	3501 (1588)	3593 (1629)	3824 (1735)	748 (339)	1544 (700)	353 (160)	255 (116)	387 (176)	256 (116)

TABLE 16 — Torque Requirements ★

For Dry Fasteners – Inch															
SAE	DIA	1/4	5/16	3/8	7/16	1/2	9/16	5/8	3/4	7/8	1	1-1/8	1-1/4	1-3/8	1-1/2
General Purpose Grade 2	Torque (ft-lb)	6	12	21	34	52	75	104	178	184	256	380	530	700	930
High Strength Grade 5	Torque (ft-lb)	9	18	33	53	80	116	160	285	460	690	850	1200	1570	2080
Alloy Steel Grade 8	Torque (ft-lb)	13	26	47	74	114	164	225	400	650	970	1370	1940	2540	3370

For Dry Fasteners – Metric															
Grade	Nominal Dia	M5	M6	M7	M8	M10	M12	M14	M16	M18	M20	M22	M24	M27	M30
8.8	Torque (Nm)	6.15	10.5	17.5	26	51	89	141	215	295	420	570	725	1070	1450
10.9	Torque (Nm)	8.65	15	25	36	72	125	198	305	420	590	800	1020	1510	2050
12.9	Torque (Nm)	10.4	18	29	43	87	150	240	365	500	710	960	1250	1810	2450

★ The torques shown produce a clamp load of 80% of proof load. They assume clean, dry threads with a torque coefficient of 1.2, and a coefficient of friction of 0.14.
 Plated threads need only ¾ torque shown.
 Well lubricated threads need only ½ torque shown.
 Source: Rexnord Engineering Specification: GES8-19, 04/10/79.

Section X — Tables: Replacement Seals and Bearings

TABLE 17 — Bearings for Standard Speed Reducers – (All Bearings are “Timken” Unless Noted Otherwise)

REDUCER SERIES	Input Bearings		Output Bearings	
	Inboard Cup/Cone	Outboard Cup/Cone	Inboard Cup/Cone	Outboard Cup/Cone
Jupiter Plus (Single, Double, Triple, Quadruple)	42584/42375	42584/42375	NSK 32036	NSK 32236
Jupiter Plus (Quintuple)	34478/34300	42620/42687	NSK 32036	NSK 32236

NSK = NSK Bearings

TABLE 18 — Seals for Standard Speed Reducers – (All Seals are “SKF” Unless Noted Otherwise)

REDUCER SERIES	Input Seals (Viton)		Output Seals (Viton)	
	Inboard	Outboard	Inboard	Outboard
Jupiter Plus (Single, Double, Triple, Quadruple)	N416556V	N455195V	N415489V	595473
Jupiter Plus (Quintuple)	26363TVA	CR26208	N415489V	595473

N = National Seal

CR = SKF Seal (formerly Chicago Rawhide)

NOTES

Section XII — Accessories

Contact a Rexnord Account Executive or refer to Planetgear 7000 catalog for detailed information on accessories.

Reducer with Baseplate

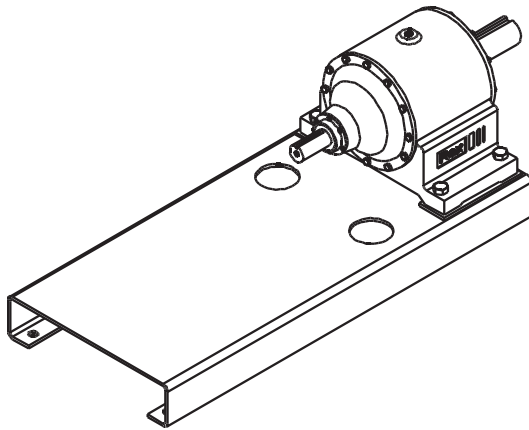

Reducer with Scoop Motor Mount

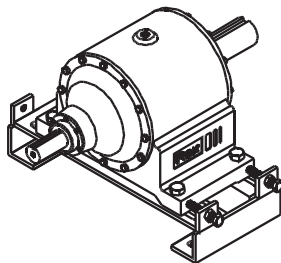
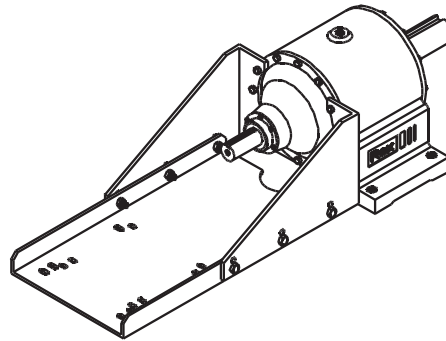

Reducer with Slidebase

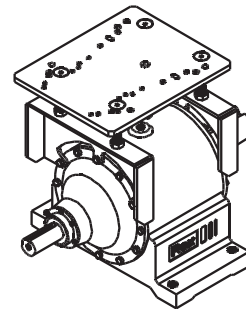

Reducer with Top Motor Mount