

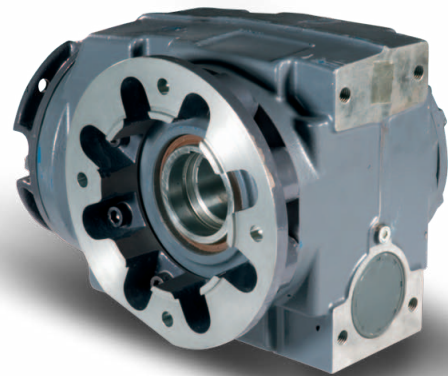

Falk Ultramite UW Right-Angle Helical Worm Gear Drives

(Inch)



FALK

FALK™ ULTRAMITE®

Delivers Local Availability, NEMA/IEC Compatibility Plus Drop-in Replacement

It's a winning combination. Start with a compact size that's the perfect fit for the .19KW/.25HP through 37KW/100HP power range. You can choose a standard plug-in high-efficiency NEMA/IEC motor from stock for an easy bolt-up mounting to the gear drive.

Add positive torque transfer without corrosion or fretting, energy efficiency over worm gear drives and quick availability no matter where you're located – and you've got the Falk Ultramite, a genuine contender in the fight for increased factory floor productivity.

What's more, the Ultramite is backed up by Rexnord, a global leader in the power transmission and conveying industry. It's got the right size, the right statistics and the right name.

The Ultramite – it delivers just the right punch.

Local Availability

The Ultramite product line is assembled from a family of convenient, cost-saving kitted sub-assemblies. The Ultramite sub-assembly kits are stocked at Rexnord facilities and distributors, offering a wide range of sizes, ratios and types for assembly. This totally modular approach to your complete gear drive and spare parts requirements ensures maximum local availability with the quickest possible turnaround times. In fact, completed assemblies can be available within hours.

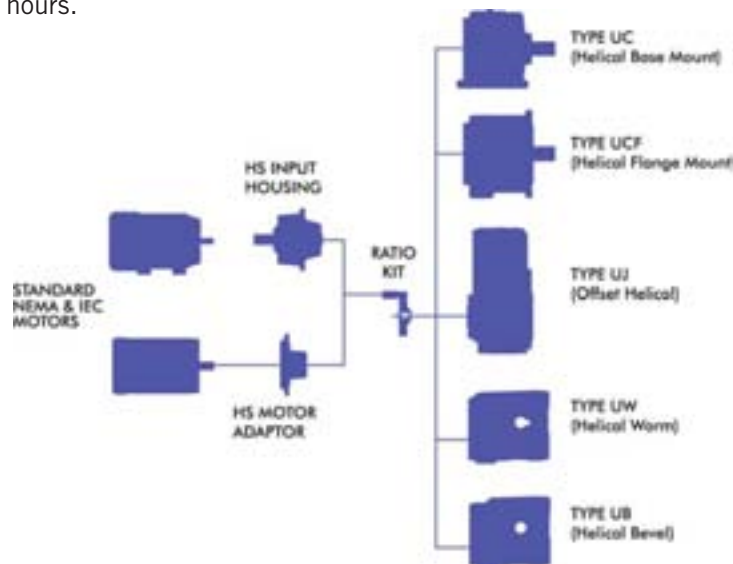
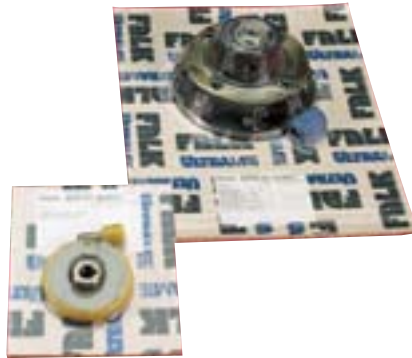

Falk Ultramite UW Right-Angle Helical Worm

- 8 sizes
- .19KW to 37KW (1/4 hp to 100 hp) capacity
- Ratios from 8:1 through 60,000:1
- C-face and solid inputs, inch or metric
- Base, shaft, or flange mounted designs
- Solid or hollow outputs with TA Taper® bushings (exclusive lifetime removal guarantee)
- Horizontal or vertical mounting

While still offering superior efficiency to traditional worm gears, this design is the lowest-cost right-angle solution in the Ultramite family. Helical, high-speed gearing and durable, long-lasting performance make it ideal wherever an affordable, low horse-power right-angle drive is required.

Customer Preferred Motors

The Ultramite accepts standard, off-the-shelf NEMA/IEC C-face and flange mounted motors, permitting the use of customer-preferred motor brands. The Ultramite accommodates industry-standard frame sizes and the choice of motor manufacturer and specifications is up to you, without costly motor adapter systems and special replacement motors – ideal for use with variable speed motors and drives.



Patented Bushing

An innovative motor bushing eliminates fretting between motor and gear drive and delivers positive torque transfer. This patented design offers easy installation and allows quick, trouble-free changeout even after years of hard, continuous use.

Application Flexibility

The modular design of the entire Ultramite product line allows accessories to be quickly and easily fitted to the drive, delivering the versatility and flexibility needed for maximum application coverage. All four designs accommodate single or double solid output shafts. Additional accessories combined with other Rexnord products, provide the ideal system match for your specific application.

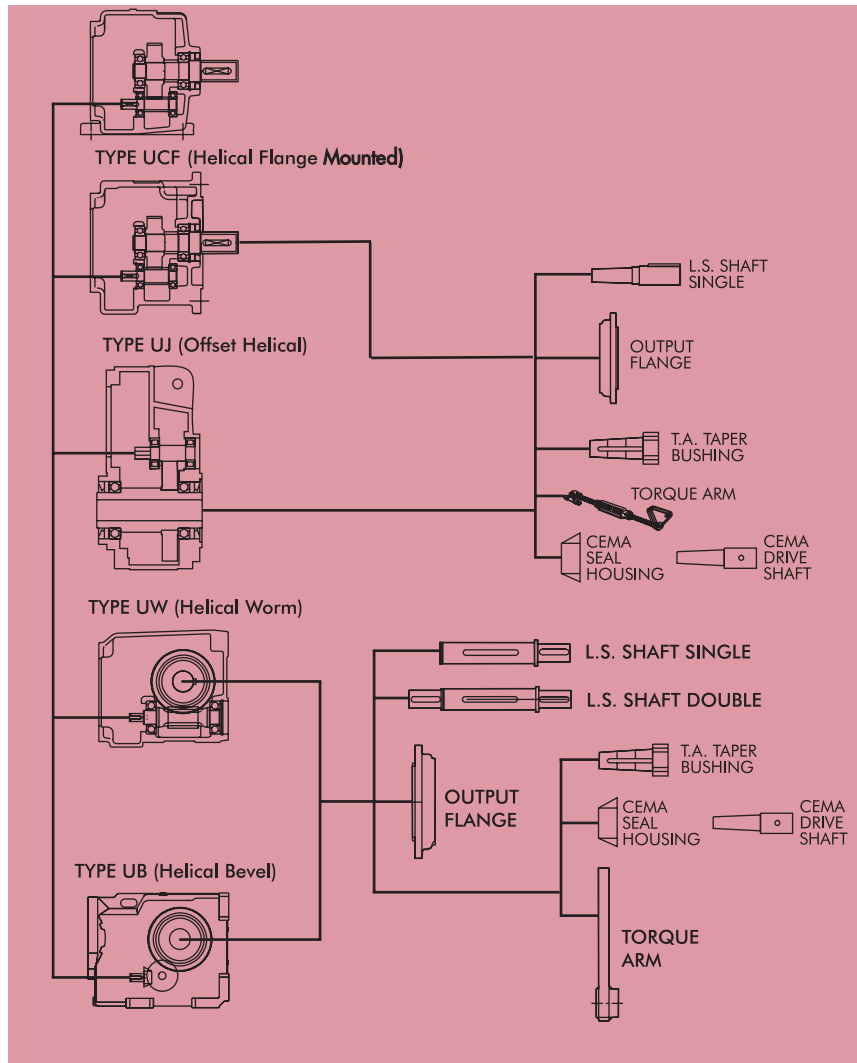

Cost Savings

Ultramite drives are more efficient than worm gearing. As a result, a smaller motor may be used at times in comparable selections, providing the customer both initial and long-term savings over worm gear drives.

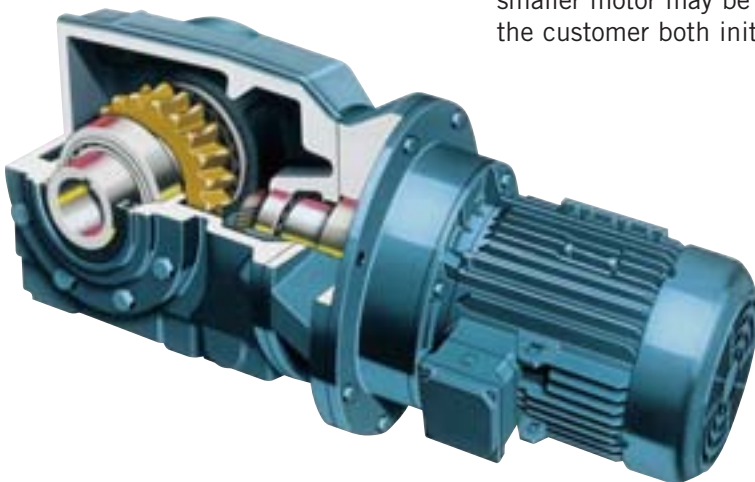

Ultramite vs. Worm Gear Drives
High Operating Efficiency Means Savings

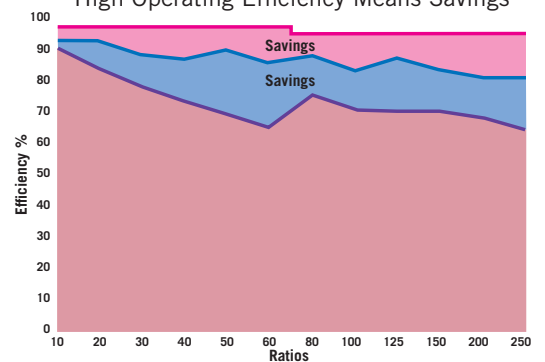

Ultramite UW Selection Guide

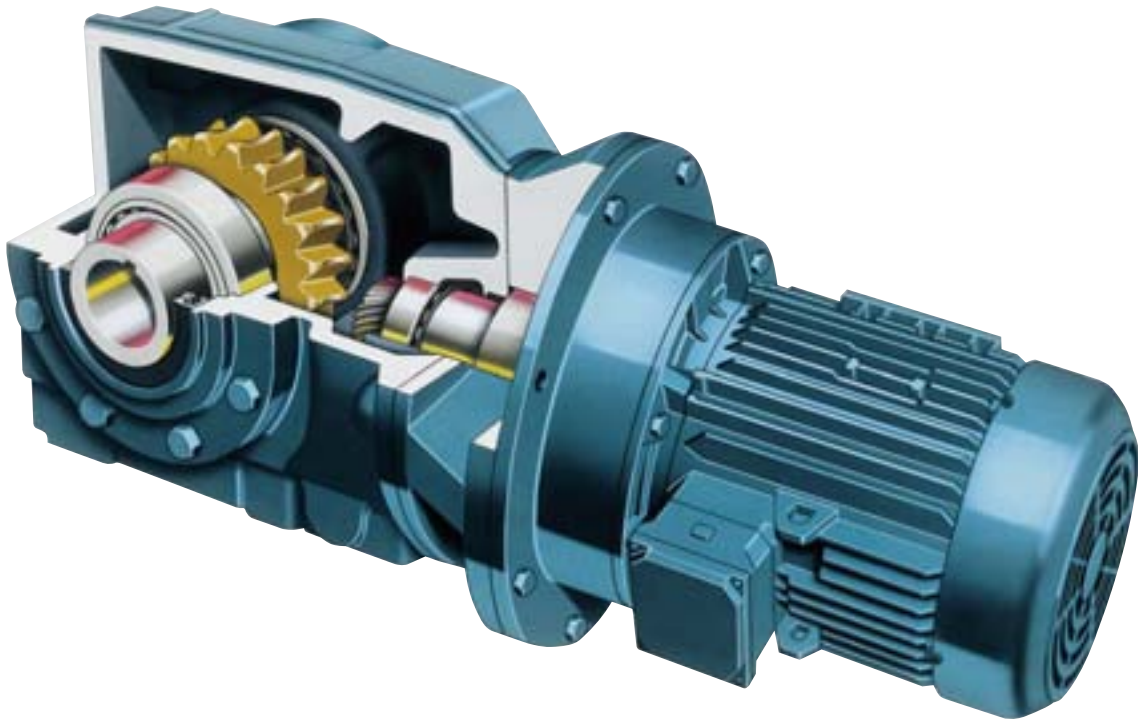

Selection Guide 281-210, May 2007

Table of Contents

UW – Right Angle Helical-Worm

UW – Basic Information & Conditions Affecting Selection	5 & 6
UW – How to Select & Order	7 & 8
UW – Gear Drives & Accessories	9
Service Factors	10 & 11
UW – Drive Nomenclature	12
UW – Thermal Ratings & Thermal Application Correction Factors	13
UW – Exact Ratios	14 & 15
UW – Drive & Motor Mounting Positions	16
UW – Motor Adapter Symbols	17 & 18
UW – Motor Detail (NEMA C-Face)	19
UW – Gearmotor Selection Tables, LSS OHL & Part Numbers	20 - 42
UW – Gear Drive Overhung Loads	55 & 56
UW – Thrust Loads	57
UW – Moments of Inertia (WR ²)	58 & 59
UW – Gear Drive Horsepower & Torque Tables	60 - 75
UW – Gear Drive Part Numbers	76 - 79
UW – Component Part Numbers	90 - 92
UW – Drive Hold Down Bolts	91
UW – Approximate Shipping Weights	94

UW – Dimensions

UW – Hollow Output Shaft (Dimensions)	93
UW – Basic Gearmotor Drive & Flange Mounted w/Drywell	43 - 54
UW – Basic Gearmotor Drive with TA Taper Bushing	51
UW – Basic Gear Drive & Flange Mounted w/Drywell	80 - 89
UW – Components & Accessories	90 - 92

Basic Information

Safety Notes

Falk Gear Drives — The Falk and Rexnord name on the gear drive is the purchaser's assurance that the drive was engineered, rated and manufactured to sound design practices.

The power supplied to the geared drive must be equal to or less than the power for which the drive was selected using the appropriate service factor for the application. The customer must also assume the responsibility of isolating the gear drive from any vibratory or transient load induced by the driven equipment.

Install and operate Rexnord products in conformance with applicable local and national safety codes and per Rexnord installation manuals which are shipped with gear drives and are also available upon request. Suitable guards for rotating members may be purchased from Rexnord as optional accessories. Consult your local Rexnord Representative for complete details.

People Conveying Equipment — Selection of Rexnord gear drives for applications whose primary purpose is the transportation of people is not approved. This includes such applications as freight or passenger elevators, escalators, man lifts, work lift platforms and ski tows and ski lifts.

If the primary purpose of the application is material conveyance and occasionally people are transported, the Rexnord warranty may remain in effect provided the design load conditions are not exceeded and certification to the appropriate safety codes and load conditions has been obtained by the system designer or end user from the appropriate enforcement authorities.

Gear Drive Ratings — All gear drive ratings in this bulletin allow 100% overload for starting loads and momentary overloads for electric motor driven applications operating 10 hours per day under uniform conditions. For other conditions, compute an equivalent horsepower by multiplying the actual horsepower required for the application by the appropriate Service Factor.

Gear Drive Identification — Tables in this selection guide identify gear drives based on the drive nomenclature.

Horsepower & Torque/Gearmotor Drives — Gearmotor Drive mechanical horsepower and delivered torque ratings are tabulated only at 1750 rpm. Horsepower, output torque, and LSS OHL ratings for Gearmotor Drives do not always correspond to those of the comparable Inline Gear Drive of the same size, reduction, and ratio. In selected cases the Gearmotor Drive will have more rating than the corresponding Inline Gear Drive. When additional rating for Gearmotor Drives at 1750 rpm input is available, it will be as stated in the Gearmotor Drive Selection Tables. For Gearmotor Drive ratings at input speeds other than 1750 rpm, consult Factory.

Horsepower & Torque/Gear Drives — Gear Drive mechanical horsepower and output torque ratings are tabulated in the Selection Guide to permit selections for specific application requirements. When the required input speed falls between two tabulated input speeds of a specific drive designation (size, reduction and ratio), interpolate to determine drive rating.

Lubricants — Drive Sizes 03, 04, 05 & 06UW will be supplied filled with a quantity of Glygoyle HE Synthetic lubricant suitable for the drive mounting position specified at the time of the order.

Drive Sizes 07, 08, 09 & 10UW are supplied without lubricant. The appropriate fill quantities and lubricant recommendations are stated in Manual 288-200 for UW drives.

Stored & Inactive Gear Drives — Each gear drive is protected with rust preventive that will protect parts against rust for a period of 6 months in an indoor dry shelter.

Sizes 07 thru 10UW — If a gear drive is to be stored, or is inactive after installation beyond the above periods, drain oil from housing and spray all internal parts with a rust preventive oil that is soluble in lubricating oil or add "Motorstor"™ vapor phase rust inhibitor at the rate of one ounce per cubic foot of internal drive space (or 5% of sump capacity) and rotate the shafts several times by hand. Before operating, drives which have been stored or inactive must be filled to the proper level with oil meeting the specifications given in Manual 288-200 for UW drives. Refer to Manual 128-014 for "Start-up after Storage" instructions.

Periodically inspect stored or inactive gear drives and spray or add rust inhibitor every six months, or more often if necessary. Indoor dry storage is recommended.

Gear drives ordered for extended storage can be treated at the Factory with a special preservative and sealed to rust-proof parts for periods longer than those cited previously.

Factory Warranty — Falk products generally carry a limited, one-year warranty against defects in materials or workmanship; but for an actual statement of the Factory Warranty, ask your local Rexnord Representative or Falk/Rexnord Distributor for our Standard Conditions of Sale.

Conditions Affecting Selections

Non-Standard Application Procedures

The following conditions may affect the gear drive selection procedure, drive size and auxiliary equipment being furnished.

Excessive Overloads — The maximum momentary or starting load must not exceed 200% of rated load (100% overload). Rated load is defined as gear drive rating with a Service Factor of 1.0. If the maximum starting or momentary load exceeds the above conditions, compute a second equivalent horsepower by dividing the peak load by two. The gear drive selected must have capacity equal to, or in excess of, the larger equivalent horsepower.

Reversing Service — Applications involving either more than 20 reversals per 10 hour period, or less than 20 reversals per 10 hour period with peak torques greater than 200% of normal load must be referred to Factory.

Stop and Start Service — Applications involving frequent stop and start overloads in excess of 10 times per day must be referred to Factory.

Brake Equipped Applications — When a gear drive is equipped with a “working” brake that is used to decelerate the motion of the system and the brake is located between the prime mover and the gear drive or on the rear of the motor, select the drive based on the brake rating or the highest equivalent horsepower, whichever is greater. If the brake is used for holding only and is applied after the motion of the system has come to rest, the brake rating must be less than 200% of the catalog rating, refer the application to Factory. Also refer to Factory all applications in which the brake is located on the output shaft of the gear drive.

Oversize Prime Mover — Published Service Factors do not cover applications that require oversize prime movers for high energy or peak loads. Refer such applications to Factory for selection of suitable drives.

Speed Variation — Gear drives offered in this Selection Guide are designed to operate with splash lubrication at all speeds for which they are catalogued, provided the appropriate amount of lubricant is present based on the drive mounting position (Refer to Manual 288-200 for oil quantity associated with each gear drive mounting position). Variation of speed between cataloged speeds, or at speeds falling between cataloged speeds, is permissible.

Lubrication of Sizes 03, 04, 05 & 06UW — These four sizes are furnished filled with a quantity of oil. Quantity of oil furnished is based on the customer identified drive mounting position stated at the time of order. Standard drive mounting positions (positions 1 thru 6) are shown on Page 16 of this Selection Guide. These four sizes have one oil drain plug. Standard oil furnished with the gear drive is a polyalphaolefin (PAO) based synthetic lubricant conforming to AGMA Viscosity Grade 7S, ISO Viscosity Grade 460, and no further lubrication of the gear drive is required.

Lubrication of Sizes 07, 08, 09 & 10UW — These sizes are furnished without oil. Customer oil fill is required. They are furnished with oil fill plug, oil drain plug, and vent plug. Lubricant quantity lubricant specifications, location of plugs, and recommended oil change frequency are stated in the Installation & Maintenance Guide 288-200 for UW drives.

General Information

- Rexnord standards apply unless otherwise specified.
- All dimensions are for reference only and are subject to change without notice unless certified.
- H.S. Shaft or HSS = High Speed Shaft.
- L.S. Shaft or LSS = Low Speed Shaft.

Other Lubricants for UW Drives — The use of other lubricants will cause a mechanical and thermal derating of the drive. Use of a straight mineral lubricant will derate the drive by 15%.

Variable or Multi-Speed Applications – All Types

When selecting gear drives for multi-speed or variable speed application, determine the speed which develops the greatest torque and select the drive on this basis. If the speed is not listed in the selection table, use the next lower speed.

Effects of Solar Energy — If a drive operates in the sun at ambient temperatures over 100°F, then special measures must be taken to protect the drive from solar energy. This protection can consist of a canopy over the drive or reflective paint on the drive. If neither is possible, a heat exchanger or other cooling device may be required.

Overhung Loads and Thrust Loads — The overhung load and thrust load ratings published in this bulletin are based on a combination of the most unfavorable conditions of rotation, speed, direction of applied load and drive loading. If the calculated load exceeds the published value, or if an overhung load and thrust load are applied simultaneously to a shaft, refer complete application information to Factory.

Non-Standard Mounting Positions — For non-standard mounting positions (other than those shown in this Selection Guide) refer to Factory for lubricant level and quantity.

Double Seal Option — Certain applications may dictate the use of double seals. This option, provided at an additional charge, is furnished as follows:

Gearmotors — A double seal is available only at the low speed shaft.

Inline Drives — A double seal is furnished at both the high speed and low speed shafts.

Operating Temperature for UW Drives — Thermal ratings published are for helical-worm gearmotors and are based upon the drive being mounted in position #1, ambient temperature equal to 68°F(20°C) and the drive to be mounted with a TEFC motor only. The UW helical-worm drives are thermally limited in many cases. Helical-worm gearmotor selections should be checked by using the Thermal Rating Adjustment Table on Page 13. Consult Factory when not using a TEFC motor or if the helical-worm gear drive selection exceeds 80% of the published thermal rating of the comparable motorized drive after applying the Thermal Application Correction Factor Formula on Page 13.

Reference Notes

- ★ Dimensions are for reference only and will vary with motor manufacturer.
- † For higher ratio selections, consult Factory. Check thermal input hp ratings. Selection tables are based on mechanical input hp ratings only.
- ‡ Thermal ratings are based upon the fitting of TEFC motor on gearmotors. For gear drives consult Factory.

UW – How to Select & Order Gearmotors

Before making any selections, refer to the Basic Information and Conditions Affecting Selections on Pages 5 and 6.

Selection of Helical-Worm Gearmotors

1. Determine Service Factor — See Pages 10 & 11.
2. Determine Motor Horsepower.
3. Determine Gearmotor Output Speed and Ratio.
4. Gearmotor Selection tables are included on Pages 20 through 42. These tables assume a motor base speed of 1750 rpm.

For ratings at other motor base speeds, consult your authorized Rexnord Sales Representative.

Go to the page that contains selections based on the specific C– Face motor you will be using. For example, selections for .50 hp, 1750 rpm, 56C frame motors are tabulated on Pages 24 & 25.

Starting at the top of the first selection page pertinent to your motor requirement, move down the selections until a gearmotor meeting your output speed, ratio, reduction, and service factor requirements is located.

For example consider an application with a .50 hp, 1750 rpm/56C frame motor, output speed of 45 rpm, nominal ratio of 40:1, and a required service factor of 1.75.

Pages 24 & 25 contains selections for a .50 hp, 1750 rpm/56C frame motor.

The Gearmotor 03UWAQ2A40.A_A (basic drive) has an output speed of 45 rpm, exact ratio of 39.26:1, double reduction, and a service factor of 1.88 which meets our requirements.

Choose required drive, either a standard Hollow L.S. Shaft Basic Drive or a Hollow L.S. Shaft with Drywell Flange Mounted Drive. Record the full nomenclature and part number.

5. Components/Accessories — Selection, dimensions and part numbers for components to meet your configuration requirements, are found on Pages 20 through 54. Indicate if components are to shipped loose or mounted for an additional charge.
6. Check thermal ratings.
7. Check Overhung Load — The helical-worm gearmotor selection tables provide the low speed shaft overhung capacity of the gearmotor selected. If overhung load is present, calculate the value of the overhung load per instructions on Page 55. Sprockets or other devices mounted on the output shaft of the gearmotor should be sized and positioned so the gearmotor load capacities are not exceeded. If applied overhung loads exceed the capacity of the initial gearmotor selected, a larger gearmotor with adequate capacity must be selected.
8. Check External Thrust Load — Permissible thrust loads are provided on Page 57. If thrust and overhung loads are applied simultaneously, or if loads exceed stated thrust capacities, consult your authorized Rexnord Sales Representative.
9. Check Helical-worm Gearmotor Dimensions — Pages 43 through 54.
10. When ordering, provide the gear drive mounting position from Page 16. If a mounted motor is order, specify motor mounting position, also from Page 16.

Example

Application: Belt conveyor, heavy duty, head shaft speed is 125 rpm, basic drive configuration with Banjo Torque Arm is specified.

Duty Cycle: 16 hours per day.

Driver: 2 hp electric motor, 1750 rpm, 143TC frame.

Ambient temperature: 80°F(27°C).

1. Service Factor from Page 11 is 1.50.
2. Motor Horsepower is 2.00 hp.
3. Head shaft speed 125 rpm (ratio is $1750/125 = 14:1$)
4. From the helical-worm gearmotor selection guide on Page 32, the appropriate helical-worm gearmotor is the Size 04UWAQ2A14.A_B, part number 4760387 (shaft mounted), exact ratio 14.95:1, 1.50 service factor, overhung load of 1771 (not required for this example).
5. Specify mounting position and motor mounting position (if mounting motor is requested) from Page 16 for our example, the drive mounting position is mounted in Position #1.
6. Check Thermal Rating — From rating tables on Pages 64 & 65, find the thermal hp capacity for the drive. The thermal hp capacity for the drive is 4.02 hp. Calculate the thermal rating from the thermal formulas and tables found on Page 13.
Calculation for our example:
 $PTA = (B_1) .89 \times (B_2) 1.00 \times (B_3) 1.00 \times (P_T) 4.02 = 3.58$
which is less than catalog rating, therefore acceptable.
7. Check Overhung Load Capacity — For this example there is no overhung load.
8. Check External Thrust Load Capacity — For this example there is no external thrust.

ORDER:

1 – 04UWAQ2A14.ABB, PN 4760387 Position #1

1 – 04 Banjo Torque Arm, PN 1940571 (shipped loose)

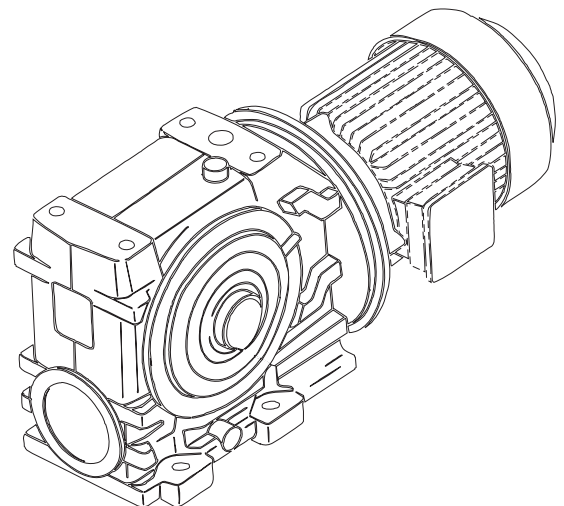

UW – How to Select & Order Gear Drives

Before making any selections, refer to the Basic Information and Conditions Affecting Selections on Pages 5 and 6.

Selection of Helical-Worm Gear Drives

1. Determine Service Factor — See Pages 10 & 11.
2. Determine Equivalent Horsepower — Calculate the equivalent hp by multiplying the motor hp by the service factor.
3. Determine drive output speed and ratio.
4. Helical-Worm Gear Drive Selection tables are included on Pages 60 through 75.
Locate the table containing your required ratio, reduction and low speed shaft rpm & select the drive size with a mechanical rating equal to or exceeding your equivalent horsepower requirement.
Having selected a Helical-Worm Gear Drive size meeting your ratio, reduction, and equivalent hp requirements, obtain nomenclature, exact ratio and Falk part number from Pages 76 through 79. Part numbers are for standard Hollow L.S. Shaft Gear Drives and Hollow L.S. Shaft with Drywell Flange Mounted.
5. Components and Accessories — Selection, dimensions and part numbers for components to meet your configurations requirements, are found on Pages 60 through 94. Indicate if components are to be shipped loose or mounted for an additional charge.
6. Check thermal ratings.
7. Check Overhung Load — Tables on Page 56 provide the overhung load capacity of the Helical-Worm Gear Drive selected. If overhung load is present, calculate the value of the overhung load per instructions on Page 55. Sprockets or other devices mounted on the output shaft of the gear drive should be sized and positioned so the gear drive load capacities are not exceeded. If applied overhung loads exceed the capacity of the initial gear drive selected, a larger gear drive of adequate capacity must be selected.
8. Check External Thrust Load — Permissible thrust loads are provided on Page 57. If thrust and overhung loads are applied simultaneously, or if loads exceed stated thrust capacities, consult your authorized Rexnord Sales Representative.
9. Check Helical-Worm Gear Drive Dimensions — Pages 80 through 89.
10. When ordering, provide the drive mounting position from Page 16. If a motor is order, specify motor mounting position, also from Page 16.

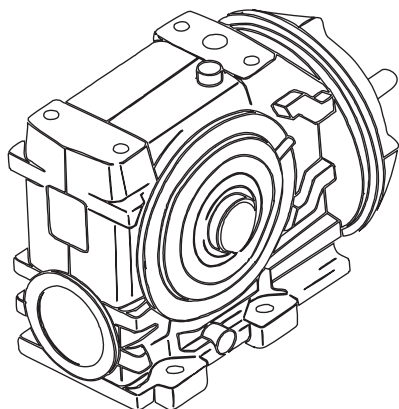

Example

Application: Belt conveyor, heavy duty, head shaft speed is 70 rpm, base mounted drive w/single ended L.S. shaft protruding left when viewing from L.S. end of drive is specified.

Duty Cycle: 16 hours per day.

Driver: 1 hp electric motor, TEFC, 1750 rpm.

Output: 3" pitch diameter sprocket with a 2:1 chain drive. Sprocket is mounted on drive output shaft such that the centerline of the overhung load is at the midpoint of the output shaft extension.

1. Service Factor from Page 11 is 1.50.
2. Equivalent Horsepower is $1.0 \times 1.5 = 1.5$ hp.
3. The head shaft speed must be multiplied by the chain drive ratio to obtain the drive output rpm ($70 \times 2 = 140$ rpm) and ratio ($1750 \div 140 = 12.5:1$).
4. From selection guide on Page 64, the appropriate helical-worm gear drive exceeding your required equivalent hp of 1.5 is the Size 03 with a service factor of 2.00 ($1.95 \text{ hp} \div 1.0 \text{ hp} = 1.95$).
Complete designation of the Helical-Worm Gear Drive is obtained from Page 76 (03UWAQ2A12.N_, exact ratio 13.20:1, and part number 4760293).
5. Components and accessories select from Pages 90 through 92. 1 – 03 Base Mounted Foot Kit (shipped loose) - Part #1940556 from Page 91.
1 – 03 Single Ended Output Shaft (shipped loose) -Part #1940531 from Page 92. (Do not have to designate left or right hand when shaft is shipped loose.)
6. Check thermal rating of drive for ambient condition. From rating tables on Pages 64 & 65, find the thermal hp capacity for the drive. The thermal input hp capacity for the drive is 2.67 hp. Calculate the thermal rating from the thermal formulas and tables found on Page 13.
Calculation for our example:
 $PTA = (B_1) .89 \times (B_2) 1.00 \times (B_3) 1.00 \times (P_T) 2.67 = 2.38$ is less than catalog rating and is greater than 2.14 (80% x 2.67 Input Thermal Catalog Rating capacity) and using a TEFC motor. Therefore selection thermally is acceptable.
7. Check Overhung Load Capacity — Allowable overhung load from Page 56 is 440 lb.
Calculate overhung load per instructions on Page 55.

$$OHL = \frac{126,000 \times 1 \times 1.00 \times 1.00}{3 \times 140} = 300 \text{ lb}$$

The overhung load capacity of the helical-worm inline drive exceeds our calculated requirements.

8. Check External Thrust Load Capacity — For this example there is no external thrust.

ORDER:

- 1 – 03UWAQ2A12.N_, PN 4760293 Position #1
- 1 – 03 Base Mounted Foot Kit - PN 1940556 (shipped loose)
- 1 – 03 Single Ended Output Shaft PN 1940531 (shipped loose)

UW – Gear Drives & Accessories

Off The Shelf Standard Right Angle Gearmotors + Modular Kits = **Availability**

UW Helical-Worm Gearmotor Drive
Basic Drive with Hollow L.S. Shaft

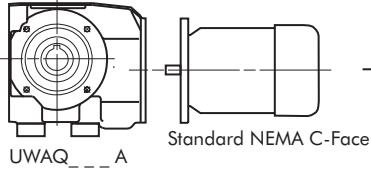

UW Helical-Worm Gear Drive
Basic Drive with Hollow L.S. Shaft

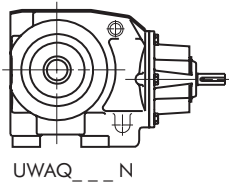

+ Single Ended Plug In L.S. Shaft

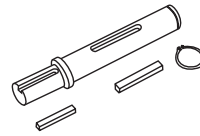

SIZES 03-10
UW_B or C

Dim. & Part No.
Page 92

+ Double Ended Plug In L.S. Shaft

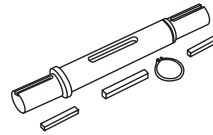

SIZES 03-10
UW_D

Dim. & Part No.
Page 92

+ Base/End Mounted Foot Kit

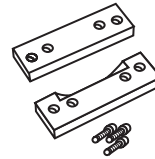

SIZES 03-06
UWA/UWD

Dim. & Part No.
Page 91

+ Top Mounted Foot Kit

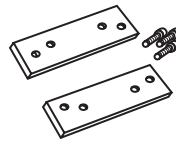

SIZES 07-10
UWE

Dim. & Part No.
Page 91

+ End Mounted Foot Kit



SIZES 07-10
UWD

Dim. & Part No.
Page 91

+ Output Flange Kit

SIZES 03-06
UWF

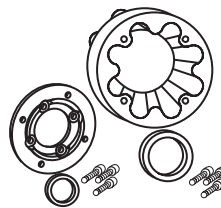

SIZES 07-10
UWF

Dim. & Part No.
Page 90

+ Banjo Torque Arm Kit

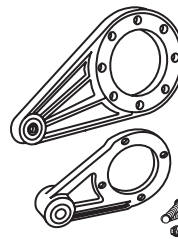

SIZES 07-10
UWK

Dim. & Part No.
Page 90

SIZES 03-06
UWK

+ TA Taper Bushing

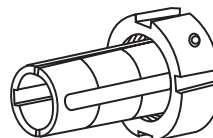

SIZES 05-10
UW_N

Dim. & Part No.
Page 52

Type UW Service Factors

A gear drive is rated to a specified application by the use of Service Factors. Each application has its own conditions and operating requirements. These have been analyzed and catalogued. Numerical values, based on field experience, have been assigned to these classifications for intermittent service of 3 to 10 hours per day and for service over 10 hours per day and also for the type of prime mover . . . electric motor or engine. Values for most applications are listed by Application on Page 11, Table 3 and by Industry at right, Table 2.

Examples — A comparison of three different applications, each operating 16 hours per day, will illustrate the function of Service Factors: an Assembly Conveyor, uniformly loaded (SF = 1.25), a Belt Conveyor, heavy duty (SF = 1.50) and a Laundry Washer (SF = 2.00). If each of these applications

requires 10 hp, each drive is selected for a rating of 10 hp times the Service Factor — that is, for 12.5, 15 and 20 hp respectively. Thus, the Service Factor takes into consideration the varying conditions of operation: Laundry Washer service is relatively more severe than that of a uniformly loaded Assembly Conveyor, etc.

Since most industrial applications are electric motor driven, Service Factors are based on the use of electric motors. These factors can be easily converted to engine-drive factors as outlined in Table 1.

Service Factors are based on the assumption that the system is free of dynamic vibrations, as explained in the warranty section, and that maximum momentary or starting loads do not exceed 200% of the rated load.

Service Factors listed are recommended as minimum for general purpose use. Application of these service factors will result in normal drive reliability and life under typical operation conditions. Refer to Factory any application not listed in Tables 2 or 3.

Applications involving unusual operating conditions or requirements such as, but not limited to, the following should also be referred to Factory:

- Applications requiring extended life/High reliability exceeding normal
- High frequency starting
- Stalling or other high energy load absorption
- Torsional vibrations
- Frequent speed variations
- Reversing loads
- Extremes in ambient temperature

Occasional & Intermittent Service or Engine Driven Applications

For multi-cylinder engine driven applications and all applications operating intermittently up to 3 hours per day, refer to Table 2 or 3 for the Service Factor of the same application operating 3 to 10 hours per day. Next, in the first column of Table 1, find this same Service Factor in bold face type. Then, to the right, under the desired hours service and prime mover, locate the converted Service Factor.

For example, from Table 3, the Service Factor is 1.25 for a uniformly loaded belt conveyor. From Table 1, for the same application the following are the Service Factors for various conditions.

1. Engine driven 3 to 10 hours per day; use 1.50 Service Factor.
2. Engine driven up to 3 hours intermittently; use 1.25 Service Factor.
3. Motor driven up to 3 hours intermittently; use 1.00 Service Factor.

TABLE 1 — Service factor conversions

Table 2 or 3 3 to 10 Hour Service Factor	3 to 10 Hours per Day	Over 10 Hours per Day		Intermittent—Up to 3 Hours per Day †	
	Multi-Cyl. Engine ‡	Motor	Multi-Cyl. Engine ‡	Motor	Multi-Cyl. Engine ‡
1.00	1.25	1.25	1.50	1.00	1.00
1.25	1.50	1.50	1.75	1.00	1.25
1.50	1.75	1.75	2.00	1.25	1.50
1.75	2.00	2.00	2.25	1.50	1.75
2.00	2.25	2.25	2.50	1.75	2.00

† For applications operating one half hour or less per day and applications driven by single cylinder engines, refer to Factory.

‡ These service factors are based on the assumption that the system is free from serious critical and torsional vibrations and that maximum momentary or starting loads do not exceed 200% of the normal load.

TABLE 2 — Type UW service factors listed by industry

for electric motor, steam turbine or hydraulic motor drives . . . recommendations are MINIMUM and normal conditions are assumed

Industry	Service		Industry	Service	
	3 to 10 Hour	Over 10 Hour		3 to 10 Hour	Over 10 Hour
BOTTLING AND BREWING			Jordan	1.50	
Bottling Machinery	1.25	1.25	Kiln Drive	1.50	
Brew Kettles, Continuous Duty	1.25	1.25	Mt. Hope & Paper Rolls	1.50	
Can Filling machines	1.25	1.25	Plaiter	1.50	
Cookers—Continuous Duty	1.25	1.25	Presses (Felt & Suction)	1.50	
Mash Tubs—Continuous Duty	1.25	1.25	Reel (Surface Type)	1.50	
Scale Hoppers—Frequent Starts	1.25	1.50	Screens Chip & Rotary	1.50	
CLAY WORKING INDUSTRY			Size Press	1.50	
Clay Working Machinery	1.25	1.50	Thickener & Washer AC Motor	1.50	
Pug Mills	1.25	1.50	DC Motor	1.50	
DISTILLING	See Brewing		Vacuum Pumps	1.50	
FOOD INDUSTRY			Wind & Unwind Stand	1.25	
Beet Slicers	1.25	1.50	Winders (Surface Type)	1.25	
Bottling, Can Filling Machine	1.25	1.25	PLASTIC INDUSTRY		
Cereal Cookers	1.00	1.25	Batch Drop Mill, 2 smooth rolls	1.25	1.25
Dough Mixers, Meat Grinders	1.25	1.50	Calenders	1.50	1.50
LUMBER INDUSTRY			Compounding Mills	1.25	1.25
Conveyors			Continuous Feed, Holding & Blend Mill	1.25	1.25
Burner	1.25	1.50	Intensive Internal Mixers		
Main or Heavy Duty	1.50	1.50	Batch Mixers	1.75	1.75
Re-Saw Merry-Go-Round	1.25	1.50	Continuous Mixers	1.50	1.50
Slab	1.75	2.00	RUBBER INDUSTRY		
Transfer	1.25	1.50	Batch Drop Mill, 2 smooth rolls	1.50	1.50
Chains—Floor	1.50	1.50	Calenders	1.50	1.50
Chains—Green	1.50	1.75	Cracker Warmer—2 roll, 1 corrugated roll	1.75	1.75
Cut-Off Saws—Chain & Drag	1.50	1.75	Holding, Feed & Blend Mill— 2 Roll	1.25	1.25
Feeds—Edger	1.25	1.50	Intensive Internal Mixers		
Feeds—Gang	1.75	1.75	Batch Mixers	2.00	2.00
Feeds—Trimmer	1.25	1.50	Continuous Mixers	1.50	1.50
Log Turning Devices	1.75	1.75	Mixing Mill—2 smooth rolls (if corrugated rolls are used, use Cracker Warmer service factors)	1.50	1.50
Planer Feed	1.25	1.50	Refiner—2 roll	1.50	1.50
Planer Tilting Hoists	1.50	1.50	SEWAGE DISPOSAL		
Rolls—Live—Off Bearing— Roll Cases	1.75	1.75	Bar Screens	1.25	1.25
Sorting Table, Tipple Hoist	1.25	1.50	Chemical Feeders	1.25	1.25
Transfers—Chain & Craneway	1.75	2.00	Collectors	1.25	1.25
Tray Drives	1.25	1.50	Dewatering Screens	1.50	1.50
OIL INDUSTRY			Scum Breakers	1.50	1.50
Chillers	1.25	1.50	Slow or Rapid Mixers	1.50	1.50
Paraffin Filter Press	1.25	1.50	Thickeners	1.50	1.50
Rotary Kilns	1.25	1.50	Vacuum Filters	1.50	1.50
PAPER MILLS ★			TEXTILE INDUSTRY		
Agitator (Mixer)	1.50		Batchers, Calenders	1.25	1.50
Agitator for Pure Liquids	1.50		Card Machines	1.25	1.50
Beater	1.50		Dry Cans, Dryers	1.25	1.50
Breaker Stack	1.50		Dyeing Machinery Looms, Mangles, Nappers, Pads	1.25	1.50
◆ Calendar	1.50		Slashers, Soapers, Spinners, Tenter Frames, Washers, Winders	1.25	1.50
Chipper	2.00				
Chip Feeder	1.50				
Coating Rolls	1.50				
Conveyors— Chip, Bark, Chemical	1.50				
Couch Rolls	1.50				
Cylinder molds	1.50				
◆ Dryers — Paper Mach. & Conveyor Type	1.50				
Embosser	1.50				
Extruder	1.50				
Fourdrinier Rolls— Lumpbreaker, Wire Turning Dandy & Return Rolls	1.50				

★ Service Factors for paper mill applications are applied to the nameplate rating of the electric drive motor at the motor rated base speed and are consistent with those shown in TAPPI standards.

Anti-friction bearings only.

TABLE 3 — Type UW service factors listed by application

for electric motor, steam turbine or hydraulic motor drives . . . recommendations are MINIMUM and normal conditions are assumed

Application	Service		Application	Service		Application	Service		Application	Service		
	3 to 10 Hour	Over 10 Hour		3 to 10 Hour	Over 10 Hour		3 to 10 Hour	Over 10 Hour		3 to 10 Hour	Over 10 Hour	
AGITATORS			Reciprocating			GRAVITY DISCHARGE ELEVATORS			Centrifugal	1.25	1.25	
Pure Liquids	1.25	1.25	Multi-Cylinder	1.50	1.75		1.00	1.25	Proportioning	1.25	1.50	
Liquids & Solids	1.25	1.50	CONCRETE MIXERS			* HOISTS			Reciprocating			
Liquids-Variable Density	1.25	1.50	Continuous	1.25	1.50	Medium Duty	1.25	1.50	Single Act., 3 or more Cyl.	1.25	1.50	
APRON CONVEYORS			Intermittent	1.25	1.50	Skip Hoist	1.25	1.50	Double Act., 2 or more Cyl.	1.25	1.50	
Uniformly Loaded or Fed	1.25	1.50	* CONVEYORS—Uniformly loaded or Fed:			INDUCED DRAFT FANS	1.25	1.50	Rotary: Gear, Lobe, Vane	1.25	1.25	
Heavy Duty	1.25	1.50	Apron, Assembly, Belt, Bucket, Chain, Flight, Oven, Screw	1.25	1.25	KILNS		See Mills, Rotary	RECIPROCATING COMPRESSORS			
APRON FEEDERS	1.25	1.50	* CONVEYORS—Heavy Duty, Not Uniformly Fed			LAUNDRY WASHERS	1.50	2.00	Multi-Cylinder	1.50	1.75	
ASSEMBLY CONVEYORS			Apron, Assembly, Belt, Bucket, Chain, Flight, Oven, Screw	1.25	1.50	LAUNDRY TUMBLERS	1.25	1.50	ROTARY			
Uniformly Loaded or Fed	1.25	1.25	COOKERS (Brewing & Distilling), (food)	1.25	1.25	LINE SHAFTS			Pumps	1.25	1.25	
Heavy Duty	1.25	1.50	DEWATERING SCREENS (Sewage)	1.50	1.50	Driving Processing Equipment	1.25	1.50	Screens (Sand or Gravel)	1.25	1.50	
BALL MILLS		See Mills, Rotary	DISC FEEDERS	1.25	1.25	Other Line Shafts, Light	1.25	1.25	RUBBER & PLASTICS INDUSTRIES		See Table 2	
BAR SCREENS (Sewage)	1.25	1.25	DISTILLING		See Table 2	LOBE BLOWERS OR COMPRESSORS	1.25	1.50	SAND MULLERS	1.25	1.50	
BATCHERS (Textile)	1.25	1.50	DOUBLE ACTING PUMPS	2 or more Cylinders	1.25	1.50	LOOMS (Textile)	1.25	1.50	SCREENS		
BELT CONVEYORS			DOUGH MIXER (Food)	1.25	1.50	LUMBER INDUSTRY		See Table 2	Air Washing	1.00	1.25	
Uniformly Loaded or Fed	1.25	1.25	DRAW BENCH (Metal Mills) Carriage & Main Drive	1.25	1.50	MACHINE TOOLS			Rotary—Sand or Gravel	1.25	1.50	
Heavy Duty	1.25	1.50	DRYERS & COOLERS (Mills, Rotary)	1.50	1.50	Auxiliary Drives	1.25	1.25	Traveling Water Intake	1.00	1.25	
BELT FEEDERS	1.25	1.50	DYEING MACHINERY (Textile)	1.25	1.50	Bending Rolls	1.25	1.50	SCREW CONVEYORS			
BENDING ROLLS (Machine)	1.25	1.50	ELEVATORS			Main Drives	1.25	1.50	Uniform	1.25	1.25	
BLOWERS			Bucket-Uniform Load	1.25	1.50	Punch Press (Geared)	1.75	2.00	Heavy Duty or Feeder	1.25	1.50	
Centrifugal	1.25	1.25	Bucket-Heavy Duty	1.25	1.50	Tapping machines	1.75	2.00	SCUM BREAKERS (Sewage)	1.50	1.50	
Lobe	1.25	1.50	Bucket-Continuous	1.25	1.50	MANGLE (Textile)	1.25	1.50	SEWAGE DISPOSAL		See Table 2	
Vane	1.25	1.50	Centrifugal Discharge	1.25	1.25	MASH TUBS (Brewing & Distilling)	1.25	1.25	SHAKER CONVEYORS	1.75	2.00	
BOTTLING MACHINERY	1.25	1.25	* Escalators		Not Approved	MEAT GRINDERS (Food)	1.25	1.50	SHEETERS (Rubber)	1.50	1.50	
BREWING		See Table 2	* Freight		Not Approved	METAL MILLS			SINGLE ACTING PUMP	3 or more Cylinders	1.25	1.50
BUCKET			* Gravity Discharge	1.25	1.25	Draw Bench Carriages & Main Drives	1.25	1.50	* SKI TOWS & LIFTS		Not Approved	
Conveyors Uniform	1.25	1.50	* Man Lifts, Passenger		Not Approved	Pinch, Dryer & Scrubber			* SKIP HOIST	1.25	1.50	
Conveyors Heavy Duty	1.25	1.50	EXTRUDERS (Plastic & Rubber)		See Table 2	Rolls, Reversing		Refer to Factory	SLAB PUSHERS	1.50	1.50	
Elevators Continuous	1.25	1.50	FANS			Slitters	1.25	1.50	SLITTERS (Metal)	1.50	1.50	
Elevators Uniform	1.25	1.50	Centrifugal	1.25	1.25	Table Conveyors, Non-Reversing			SLUDGE COLLECTORS (Sewage)	1.25	1.25	
Elevators Heavy Duty	1.25	1.50	Forced Draft	1.25	1.25	Group Drives	1.50	1.50	SOAPERS (Textile)	1.25	1.50	
CALENDERS			Induced Draft	1.50	1.50	Wire Drawing & Flattening	1.25	1.50	SPINNERS (Textile)	1.25	1.50	
Rubber and Plastic		See Table 2	Large (Mine, etc.)	1.50	1.50	Machines	1.25	1.50	STOKERS	1.25	1.25	
Textile	1.25	1.50	Large Industrial	1.50	1.50	Wire Winding Machines	1.50	1.50	TABLE CONVEYORS (Non-Reversing)	Group Drives	1.50	1.50
CAN FILLING MACHINES	1.25	1.25	Light (Small Diameter)	1.00	1.25	MILLS, ROTARY			Tentor Frames	1.25	1.50	
CARD MACHINES (Textile)	1.25	1.50	FEEDERS			Pebble, Plain & Wedge Bar Mills	1.50		TEXTILE INDUSTRY		See Table 2	
CAR PULLERS	1.25	1.50	Apron, Belt	1.25	1.50	MIXER (Also see Agitators)			THICKENERS (Sewage)	1.50	1.50	
CEMENT KILNS		See Mills, Rotary	Disc	1.25	1.25	Concrete, Cont. & Int.	1.25	1.50	VACUUM FILTERS (Sewage)	1.50	1.50	
CENTRIFUGAL			Screw	1.25	1.50	Constant Density	1.25	1.50	VANE BLOWERS	1.25	1.50	
Blowers, Compressors, Discharge Elevators, Fans or Pumps	1.25	1.25	FLIGHT CONVEYORS			Variable Density	1.25	1.50	WINCHES (Dredges)	1.25	1.50	
CHAIN CONVEYORS			Uniform	1.25	1.25	NAPPERS (Textile)	1.25	1.50	WINDERS (Textile)	1.25	1.50	
Uniformly Loaded or Fed	1.25	1.25	Heavy	1.25	1.50	OIL INDUSTRY		See Table 2	WIRE			
Heavy Duty	1.25	1.50	FOOD INDUSTRY		See Table 2	OVEN CONVEYORS			Drawing Machines	1.25	1.50	
CHEMICAL FEEDERS (Sewage)	1.25	1.25	GENERATORS (Not Welding)	1.25	1.25	Uniform	1.25	1.25	Winding Machines	1.50	1.50	
CLARIFIERS	1.25	1.25				Heavy Duty	1.25	1.50				
CLASSIFIERS	1.25	1.50				Screw	1.25	1.50				
CLAY WORKING		See Table 2				PAPER MILLS		See Table 2				
COLLECTORS (Sewage)	1.25	1.25				* PASSENGER ELEVATORS		Not Approved				
COMPRESSORS						PEBBLE MILLS		1.50				
Centrifugal	1.25	1.25				PROPORTIONING PUMPS	1.25	1.50				
Lobe	1.25	1.50				PUG MILLS (Clay)	1.25	1.50				
						PUMPS						

* Selection of Rexnord products for applications whose primary purpose is the transportation of people is not approved. This includes such applications as freight or passenger elevators, escalators, man lifts, work lift platforms, ski tows and ski lifts. If the primary purpose of the application is material conveyance and occasionally people are transported, the Factory warranty may remain in effect provided the design load conditions are not exceeded and certification to the appropriate safety codes and load conditions has been obtained by the system designer or end user from the appropriate enforcement authorities.

Contact your local Rexnord representative for proper selection of a Falk RAM mixer drive.

UW – Drive Nomenclature

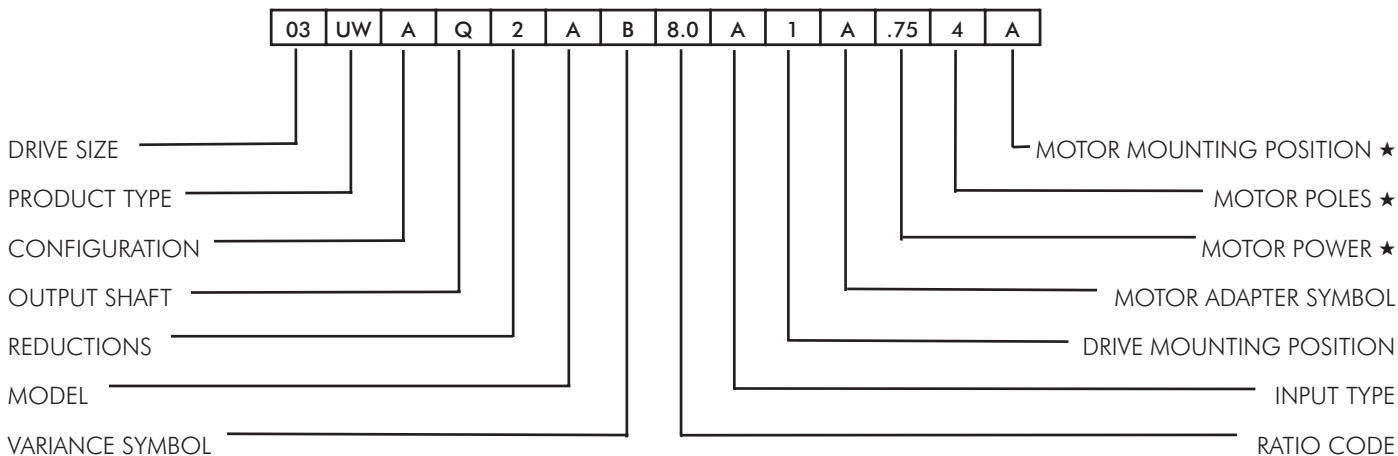

Drive Sizes

03, 04, 05, 06, 07, 08, 09 & 10

Product Type

UW — Right Angle Helical Worm

Configuration

- A — Basic Drive (Sizes 03-06) Without Feet
- B — Base Mounted Feet (07-10) Integral Feet
- C — Base Mounted Feet (03-06)
- D — End Mounted Feet
- E — Top Mounted Feet
- F — Standard Output Flange
- G — Reduced Diameter Output Flange (03 Only)
- J — With Torque Arm
- K — With Banjo Torque Arm
- X — Standard Output Flange w/Vertical Drywell (07-10)

Output Shaft

- Q — Inch Hollow
- B — Inch Single Ended, L.H. †
- C — Inch Single Ended, R.H. †
- D — Inch Double Ended
- E — Straight Metric Hollow
- F — Metric Single Ended, L.H. †
- G — Metric Single Ended, R.H. †
- H — Metric Double Ended
- J — Taper Hollow
- K — Taper Inch Single Ended, L.H. †
- L — Taper Metric Single Ended, R.H. †
- M — TA Taper Metric bushing (Bore Diameter)
- N — TA Taper Inch Bushing (Bore Diameter)
- P — CEMA Seal Housing & Drive Shaft (DS Diameters)

Reductions

- 2 — Double
- 3 — Triple
- 4 — Quadruple
- 5 — Quintuple

Model

A, B, C, etc.

† When viewed from L.S. End.

Variance Symbol

Variance Symbol B is inserted when Standard Polyglycol Lube and Single Seals are specified

- A — Standard Mineral Lube and Double Seals
- B — Standard Synthetic Lube and Single Seals
- C — Biodegradeable Lube and Single Seals
- D — Food Compatible Lube and Single Seals
- E — Synthetic Lube with Double Seals
- F — Biodegradeable Compatible Lube with Double Seals
- G — Food Compatible Lube with Double Seals
- H — Backstop (Hold Back)
- J — Cooling Fan - Shaft Driven
- S — Multiple Variances or Special

Ratio Code, Three Characters, Refer to Pages 14 & 15

- | | |
|-----------------|-----------------------------|
| 8.0 through 250 | Double Reduction |
| 100 through 900 | Triple Reduction |
| 280 through 16K | Quadruple Reduction C = 00 |
| 18K through 60K | Quintuple Reduction K = 000 |

Input Type

- A — Gear Drive with Flange Motor Adapter - NEMA Frame
- G — Gear Drive with Flange Motor Adapter - IEC Frame
- N — Gear Drive with Inch Input
- C — Gear Drive with Metric Input
- R — Gear Drive with Flange Motor Adapter - Special Motors

Drive Mounting Position, Refer to Page 16

Mounting Positions 1 through 6

Motor Adapter Symbol, Refer to Page 17 & 18

A through W

Motor Power, Decimal Point Shown ★

Horsepower – NEMA Motor
Kilowatts – IEC Motor

Motor Poles ★

- 2 — Poles, 3600 rpm @ 60 Hz, or 3000 rpm @ 50 Hz
- 4 — Poles, 1800 rpm @ 60 Hz, or 1500 rpm @ 50 Hz
- 6 — Poles, 1200 rpm @ 60 Hz, or 1000 rpm @ 50 Hz
- 8 — Poles, 900 rpm @ 60 Hz, or 750 rpm @ 50 Hz

Motor Mounting Position, Refer to Page 16 ★

When Viewed from L.S. End of Base Mounted Foot Drive.

- A — Conduit Box Horizontal on Right Side, 0°
- B — Conduit Box Vertical on Bottom Side, 90°
- C — Conduit Box Horizontal on Left Side, 180°
- D — Conduit Box Vertical on Top Side of Drive 270°

★ Motor Power, Motor Poles and Motor Mounting Position are stamped on the nameplate only if the motor is furnished & fitted by Factory.

Type UW Thermal Ratings & Thermal Application Correction Factors

The thermal ratings are a measure of the gear drives ability to dissipate heat. Checking the thermal rating is extremely important, for if the drive creates heat faster than it can be dissipated, severe damage may occur.

Quick Selection tables for Gearmotor drives are based on mechanical ratings only, while horsepower and torque tables show both mechanical and thermal ratings. It is important, however, that for both types of drives, the thermal ratings are checked to ensure that overheating does not occur.

Catalog thermal ratings are based on the drive being mounted in Position #1, operating continuously in an environment with an ambient temperature equal to 68°F (20°C). The thermal rating is affected by ambient air temperature, duty cycle and mounting position. To account for these varying conditions, the application correction factors given in Tables 1, 1A and 1B should be applied to the catalog thermal ratings using the following formula:

$P_{TA} = B_1 \times B_2 \times B_3 \times P_T$ where:

P_{TA} = Application Adjusted Thermal Power Rating

P_T = Basic Thermal Power Rating ■ (Pages 60 through 75)

B_1 = Ambient Air Temperature Factor, Table 1

B_2 = Mounting Position Factor, Table 1A

B_3 = Duty Cycle Factor, Table 1B

■ Basic thermal power ratings on Pages 60 through 75 are for gearmotors and assume the fitting of a TEFC motor. Multiply Basic Thermal Ratings by 0.80 for gearmotors not fitted with a TEFC motor and gear drives.

TABLE 1 — Ambient Air Temperature Factor - B₁

Ambient Temperature °F	-20	0	20	32	50	68	80	100	120
Factor †	1.67	1.50	1.37	1.28	1.15	1.00	0.89	0.72	0.51

† Factors for other ambient temperatures can be interpolated.

TABLE 1A — Mounting Position Factor - B₂

DRIVE Output rpm	Mounting Position				
	1	2	3 & 4	5	6
0 to 25	1.00	0.996	0.997	0.995	0.993
>25 to 50	1.00	0.990	0.993	0.986	0.982
>50 to 75	1.00	0.981	0.987	0.974	0.968
>75 to 100	1.00	0.970	0.980	0.960	0.950
>100 to 200	1.00	0.914	0.943	0.886	0.858
>200 to 300	1.00	0.844	0.896	0.792	0.840
>300 to 400	1.00	0.760	0.840	0.680	0.600
>400	1.00	0.724	0.809	0.618	0.533

TABLE 1B — Duty Cycle Factor ‡ - B₃

DRIVE Output rpm	% Operating Time Per Hour				
	100	80	60	40	20
0 to 10	1.00	1.18	1.45	1.72	2.38
>10 to 25	1.00	1.16	1.39	1.64	2.22
>25 to 50	1.00	1.14	1.31	1.54	2.00
>50 to 100	1.00	1.08	1.19	1.33	1.64
>100 to 150	1.00	1.04	1.08	1.19	1.41
>150 to 200	1.00	1.00	1.00	1.06	1.23
>200	1.00	1.00	1.00	1.00	1.00

‡ The duty cycle factor must be based on the percentage of each hour that the drive is operating. For example: A gear drive operating for 48 minutes and resting for 12 minutes every hour of the day, has an 80% duty cycle, but a drive operating for four hours and resting for four hours has a 100% duty cycle. Where % run time per hour falls between value shown above, use next higher % run time.

UW – Exact Ratios

Double Reduction

Ratio Code (3 Characters)	DRIVE SIZE								Worm Ratio
	03	04	05	06	07	08	09	10	
8.0	8.591	8.591	8.312	8.232	7.901	7.770	7.973	7.951	10
11.	11.61	11.61	11.66	11.57	10.94	11.01	10.98	11.11	10
12.	13.20	13.20	12.85	12.97	12.29	12.24	12.30	12.08	10
14.	14.95	14.95	14.59	14.56	13.52	13.61	13.81	13.72	10
16.	16.36	16.36	16.09	15.93	15.80	15.54	16.68	16.63	20
18.	19.13	19.13	18.53	18.49	17.66	17.60	17.79	17.87	10
20.	20.61	20.61	21.05	20.96	20.07	19.76	19.88	19.29	10
22.	22.11	22.11	22.56	22.40	21.89	22.03	22.96	23.23	20
25.	25.14	25.14	24.86	25.11	24.59	24.47	25.73	25.27	20
28.	28.48	28.48	28.24	28.18	27.03	27.22	28.89	28.70	20
32.	33.71	33.71	32.55	33.48	30.81	31.78	31.43	31.85	10
36.	36.43	36.43	35.86	35.79	35.31	35.20	37.22	37.38	20
40.	39.26	39.26	40.74	40.57	40.15	39.51	41.59	40.36	20
45.	45.50	45.50	46.84	47.32	44.13	43.64	44.55	43.65	10
50.	53.31	53.31	50.93	50.52	49.90	49.26	49.49	48.51	10
56.	56.19	56.19	55.45	55.71	53.63	54.60	57.66	58.85	20
63.	64.21	64.21	63.00	64.80	61.62	63.56	65.74	66.63	20
71.	74.55	74.55	73.37	73.92	69.00	69.64	69.91	69.13	10
80.	82.83	82.83	82.67	80.94	75.56	76.50	77.18	79.71	10
90.	86.67	86.67	90.67	91.58	88.26	87.29	93.18	91.32	20
100	101.5	101.5	98.57	97.78	99.79	98.53	103.5	101.5	20
112	114.3	114.3	109.1	110.6	104.3	102.4	106.2	107.8	10
125	129.9	129.9	124.0	124.0	115.9	117.9	119.4	115.8	10
140	142.0	142.0	142.0	143.1	138.0	139.3	146.2	144.7	20
160	157.8	157.8	160.0	156.7	151.1	153.0	161.4	166.7	20
212	217.8	217.8	211.1	214.0	208.6	204.8	222.1	225.5	20
250	247.5	247.5	240.0	240.0	231.8	235.8	249.7	242.3	20

Triple Reduction

Ratio Code (3 Characters)	DRIVE SIZE					Worm Ratio
	03	04	05	06	07	
100	105.4	105.4	103.9	103.9	97.33	10
118	120.4	120.4	118.7	118.0	113.2	10
132	130.1	130.1	130.4	130.0	125.0	20
150	140.2	140.2	140.5	147.7	141.7	20
160	162.5	162.5	160.3	169.8	160.0	10
180	190.4	190.4	187.8	184.6	170.8	10
200	200.7	200.7	201.1	201.0	194.7	20
225	229.3	229.3	229.8	228.4	226.4	20
265	266.3	266.3	262.6	266.0	249.9	10
280	295.8	295.8	291.8	299.7	273.7	10
315	309.5	309.5	310.2	328.7	320.0	20
360	362.6	362.6	363.4	357.3	341.6	20
400	408.3	408.3	402.7	395.4	373.8	10
450	464.1	464.1	457.7	449.5	419.3	10
500	507.1	507.1	508.2	514.8	499.9	20
560	563.5	563.5	564.7	580.0	547.4	20
800	777.8	777.8	779.4	765.3	747.7	20
900	883.9	883.9	885.8	870.0	838.5	20

UW – Exact Ratios

Quadruple Reduction

Ratio Code * (3 Characters)	DRIVE SIZE				
	06	07	08	09	10
280	283.4	284.1
315	321.3	305.1
360	346.0	341.9
400	402.5	389.0
450	441.2	436.0
500	484.4	487.4	474.3
560	563.3	552.5	545.0
630	677.2	617.5	621.5	676.4
710	736.2	684.7	704.5	777.2
800	816.2	791.7	796.4	758.8	863.4
900	871.4	860.7	873.0	882.5	895.5
10C	1040	1009	1015	967.4	994.8
11C	1111	1097	1125	1125	1143
12C	1325	1240	1202	1214	1283
14C	1415	1397	1435	1332	1450
16C	1689	1581	1532	1590	1637
18C	1803	1781	1758	1832	1851
20C	2099	1965	1925	1949	2006
22C	2241	2186	2242	2188	2196
25C	2533	2463	2455	2484	2560
28C	2705	2717	2699	2935	2804
32C	3149	3249	3353	3418	3128
36C	3481	3694	3761	3742	3426
40C	3958	4039	4036	4114	3871
45C	4334	4423	4527	4505	4301
50C	4919	5028	5002	5112	4729
56C	5386	5433	5676	5733	5255
60C	6094	6122	6366	6153	5817
65C	6507	6499	6832	6901	6396
75C	7660	7388	7663	7897	7107
85C	8388	8078	8073	8475	8521
95C	9521	9183	9054	9505	9508
10K	10425	10057	10004	9677	10412
11K	11457	10918	11352	10596	11765
12K	12849	12412	12732	12024	13072
14K	14241	13570	13665	14474	14376
16K	15971	15427	15325	16232	15973

★ Ratio with letter C = 00. Example: 20C = 2000.
 Ratio with letter K = 000. Example: 10K = 10000.

Quintuple Reduction

Ratio Code † (3 Characters)	DRIVE SIZE				
	06	07	08	09	10
18K	18096	17383	17545	18281	18884
20K	19321	19446	19627	20782	20174
22K	22492	21607	21808	22004	22731
25K	24015	23994	24218	25016	24917
28K	28272	27269	27523	28625	28326
32K	30957	32668	28852	30309	29992
36K	35140	36278	32058	34456	34096
40K	38478	41229	35600	39228	38057
43K	42286	45091	40458	43000	41716
48K	47424	45810	46589	48884	47425
53K	52560	50102	50953	51759	50214
60K	58945	56939	57907	58842	57086

† Ratio with letter K = 000. Example: 18K = 18000.

UW – Drive Mounting Position

MOUNTING 1

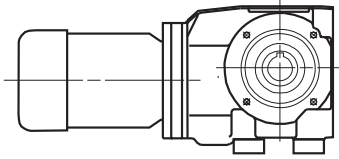

MOUNTING 2

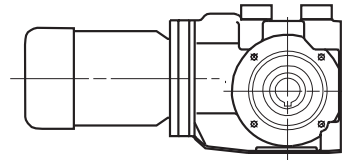

MOUNTING 3

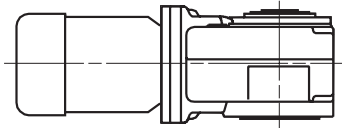

MOUNTING 4

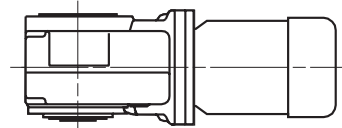

MOUNTING 5

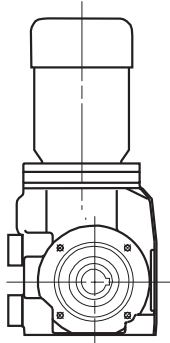

MOUNTING 6 ‡

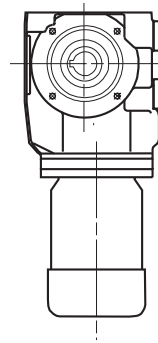

‡ Use motor fitted with a seal.

UW – Motor Mounting Position

Conduit box position when viewed from L.S. end of base mounted foot drive.

A – Conduit box horizontal on right side, 0°.

B – Conduit box vertical on bottom side, 90°.

C – Conduit box horizontal on left side, 180°.

D – Conduit box vertical on top side, 270°.

Standard NEMA motor mounting position is "C".

Standard IEC motor mounting position is "A".

VIEW FACING LS END

D (270°)

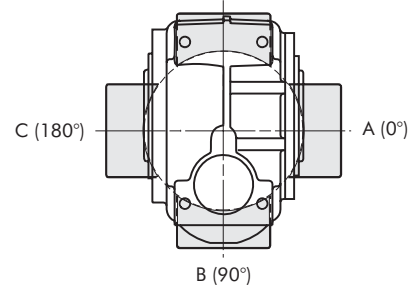

UW – Motor Adapters

The ULTRAMTE helical-worm gearmotor accommodates NEMA (Input Type “A”) or IEC (Input Type “G”) motor frame sizes. Tables 2 & 3 identify the appropriate motor adapter symbol that pertains to specific motor frame size, drive size, ratio, and reduction combinations.

If a motor adapter symbol is not listed for a particular combination of motor frame size, drive size, ratio, and reduction, then that combination is not offered.

For Gear Drives (Inputs Types “N” and “C”), the motor adapter symbol is not used.

TABLE 2 — Input Type A – NEMA Motor Adapter Symbols

Motor Frame Size	DRIVE SIZE															
	03				04				05				06			
	Double		Triple		Double		Triple		Double		Triple		Double		Triple	
	Ratio Range															
	8.0-28 36-40	32 & 45-250	132-150	100-118 160-900	8.0-28 36-40	32 & 45-250	132-150	100-118 160-900	8.0-40 56-63	45-50 71-250	132-150	100-118 160-900	8.0-28 36-40	32 & 45-250	100-150 200-225	160-180 265-900
56C 143TC/145TC 182TC/184TC	A B C	A B	A B C	A B	A B C	A B	A B C	A B	A B C	A B	A B C	A B C	A B C	A B C	A B
213TC/215TC 254TC/256TC 284TC/286TC 324TC/326TC	D

Motor Frame Size	DRIVE SIZE									
	07			08		09		10		
	Double		Triple	Double		Double		Double		
	Ratio Range									
	8.0-28 36-40	32 & 45-250	132-150	100-118 160-900	8.0-40 56-63	45-50 71-250	8.0-40 56-63	45-50 71-250	8.0-40 56-63	45-50 71-250
56C 143TC/145TC 182TC/184TC	A B C	A B C	A B C
213TC/215TC 254TC/256TC 284TC/286TC 324TC/326TC	D E	D	D	D E	D E	D E	D E

TABLE 3 — Input Type G – IEC Motor Adapter Symbols

Motor Frame Size	DRIVE SIZE															
	03				04				05				06			
	Double		Triple		Double		Triple		Double		Triple		Double		Triple	
	Ratio Range															
8.0-28 36-40	32 & 45-250	132-150	100-118 160-900	8.0-28 36-40	32 & 45-250	132-150	100-118 160-900	8.0-40 56-63	45-50 71-250	132-150	100-118 160-900	8.0-28 36-40	32 & 45-250	100-150 200-225	160-180 265-900	
63/D	A	A	A	A	A	A	A	A	A	A	A	A	A
71/D	B	B	B	B	B	B	B	B	B	B	B	B	B
71/C	C	C	C	C	C	C	C	C	C	C	C	C	C
80/D	D	D	D	D	D	D	D	D	D	D	D	D	D	D	D	D
80/C	E	E	E	E	E	E	E	E	E	E	E	E	E	E	E	E
90/D	F	F	F	F	F	F	F	F	F	F	F	F	F	F	F	F
90/C	G	G	G	G	G	G	G	G	G	G	G	G	G	G	G	G
100/D	H	H
100/C	J	J	J	J	J	J	J	J	J	J	J	J	J	J	J	J
112/D	K	K
112/C	M	M	M	M	M	M	M	M	M	M	M	M	M	M	M	M
132/D	N	N
132/C	P	P
160/D
180/D
200/D
225/D

Motor Frame Size	DRIVE SIZE									
	07			08		09		10		
	Double		Triple	Double		Double		Double		
	Ratio Range									
8.0-28 36-40	32 & 45-250	132-150	100-118 160-900	8.0-40 56-63	45-50 71-250	8.0-40 56-63	45-50 71-250	8.0-40 56-63	45-50 71-250	
63/D	A	
71/D	B	
71/C	C	
80/D	D	D	D	D	D	
80/C	E	E	E	
90/D	F	F	F	F	F	
90/C	G	G	G	
100/D	H	H	H	H	H	H	H	H	
100/C	J	J	J	J	
112/D	K	K	K	K	K	K	K	K	
112/C	M	M	M	M	
132/D	N	N	N	N	N	N	N	N	
132/C	P	P	P	P	
160/D	R	R	R	R	R	R	
180/D	T	T	T	
200/D	U	U	U	
225/D	W	W	W	

Motor Detail (NEMA C-Face)

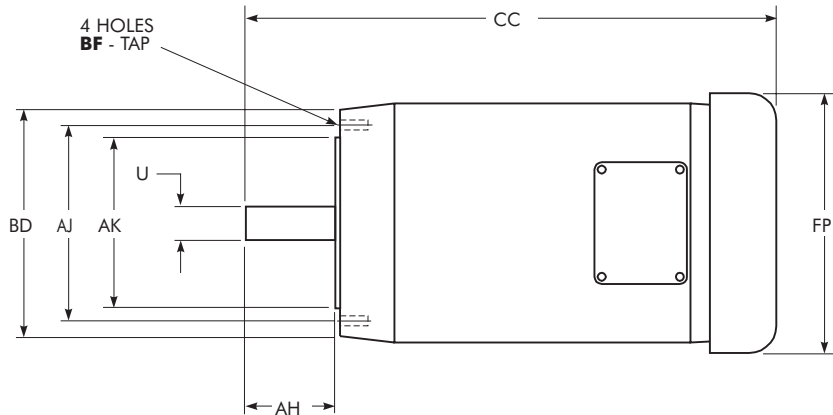

TABLE 4 — Typical Motor Dimensions – Inches

MOTOR FRAME SIZE	BD	AJ	AK	U	AH	CC Max	FP	BF Tap UNC
56C	6.50	5.88	4.5	0.625	2.06	11.38	7.19	0.375-16
143TC/145TC	6.50	5.88	4.5	0.875	2.12	14.19	7.19	0.375-16

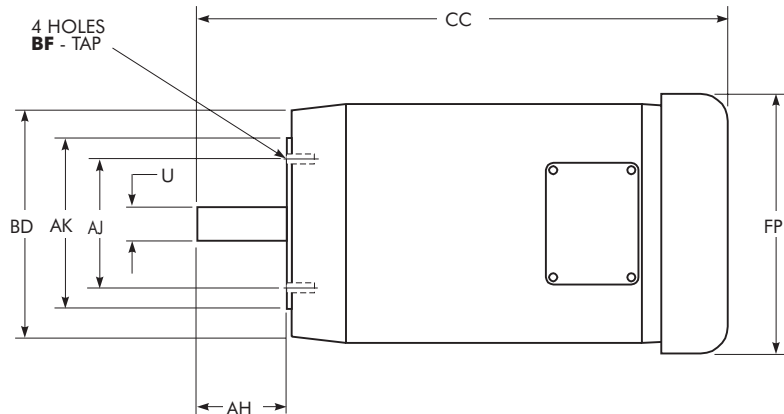

TABLE 5 — Typical Motor Dimensions – Inches

MOTOR FRAME SIZE	BD	AJ	AK	U	AH	CC Max	FP	BF Tap UNC
182TC/184TC	9.00	7.25	8.5	1.125	2.63	18.06	8.50	0.50-13
213TC/215TC	9.00	7.25	8.5	1.375	3.13	19.44	10.19	0.50-13
254TC/256TC	10.00	7.25	8.5	1.625	3.75	23.63	12.50	0.50-13
284TC/286TC	11.25	9.00	10.5	1.875	4.38	27.56	15.56	0.50-13
324TC/326TC	13.38	11.00	12.5	2.125	5.00	30.25	16.94	0.63-11
364TC/365TC	13.38	11.00	12.5	2.375	5.63	32.56	19.00	0.63-11
404TC/405TC	13.88	11.00	12.5	2.875	7.00	36.88	20.63	0.63-11

UW – Gearmotor Selection Table †

0.25 HP/1750 rpm/56C Frame Motor

(Also use these selections for UW drives with TA bushing. Refer to Falk for Part No.)

Approx Output rpm	Exact Ratio	Actual Output Torque (lb-in)	Service Factor	Overhung Load (lb)	Hollow L.S. Shaft Basic Drive Gearmotor Less Motor Inch Dimensioned	
					Drive Designation	Part No.
204	8.59	65	10.60	454	03UWAQ2A8.0A_A	4760282
151	11.61	87	8.56	454	11.	4760286
133	13.20	99	7.80	454	12.	4760290
117	14.95	112	7.16	451	14.	4760294
107	16.36	109	6.80	454	16.	4760298
91	19.13	142	6.00	451	18.	4760302
85	20.61	153	5.72	451	20.	4760306
79	22.11	145	5.56	451	22.	4760310
70	25.14	164	5.12	451	25.	4760314
61	28.48	185	4.68	451	28.	4760318
52	33.71	245	4.00	451	32.	4760322
48	36.43	233	3.96	451	36.	4760325
45	39.26	250	3.76	451	40.	4760329
38	45.50	327	3.20	449	45.	4760333
33	53.31	380	2.84	449	50.	4761814
31	56.19	350	2.96	449	56.	4760338
27	64.21	397	2.68	449	63.	4760341
23	74.55	526	2.36	447	71.	4760344
21	82.83	582	2.16	447	80.	4760347
20	86.67	525	2.28	447	90.	4760350
17	101.54	611	2.04	447	100	4760353
15	114.33	793	1.76	445	112	4760356
13	129.94	895	1.44	442	125	4760359
12	142.00	834	1.60	445	140	4760362
11	157.78	919	1.48	442	160	4760365
8.0	217.78	1245	1.12	440	212	4760368
7.1	247.50	1408	1.00	438	250	4760371
17	105.36	718	1.88	440	03UWAQ3A100A_A	4761430
15	120.39	820	1.68	440	118	4761433
13	130.10	745	1.68	440	132	4761436
12	140.21	805	1.60	440	150	4761440
11	162.50	1096	1.28	436	160	4761444
9.2	190.38	1276	1.08	433	180	4761447
8.7	200.68	1130	1.24	436	200	4761450
7.6	229.32	1282	1.08	433	225	4761453
23	74.55	532	3.52	1771	04UWAQ2A71.A_A	4760437
21	82.83	587	2.96	1771	80.	4760440
20	86.67	537	3.64	1771	90.	4760443
17	101.54	622	3.24	1771	100	4760446
15	114.33	799	1.92	1771	112	4760449
13	129.94	901	1.44	1771	125	4760452
12	142.00	849	2.56	1771	140	4760455
11	157.78	935	2.36	1771	160	4760458
8.0	217.78	1269	1.88	1771	212	4760461
7.1	247.50	1426	1.44	1771	250	4760464
17	105.36	730	2.52	1771	04UWAQ3A100A_A	4761486
15	120.39	830	2.20	1771	118	4761489
13	130.10	765	2.64	1771	132	4761492
12	140.21	822	2.52	1771	150	4761496
11	162.50	1108	1.64	1771	160	4761500
9.2	190.38	1294	1.40	1771	180	4761503
8.7	200.68	1156	2.00	1771	200	4761506
7.6	229.32	1314	1.84	1771	225	4761509
6.6	266.25	1781	1.00	1771	265	4761512
5.9	295.83	1972	0.92	1771	280	4761515
5.7	309.52	1743	1.56	1771	315	4761518
4.8	362.64	2028	1.40	1771	360	4761521
3.5	507.14	2774	1.00	1764	500	4761530
16	109.07	785	3.96	1674	05UWAQ2A112A_A	4761815
14	124.00	886	3.00	1674	125	4760547
8.3	211.11	1277	3.84	1674	212	4760556
7.3	240.00	1438	3.00	1674	250	4760559

Motors are available from Rexnord or Rexnord Distributors.

.25 HP/56C Motor Falk Part No. 1940393 Conforms to the following specifications:

C Face motor less base, TEFC, 1750 rpm, 208-230/460 Volts, 3 Phase, 60 Hz, NEMA B, 1.15 Service Factor.

Motors meeting other specifications are available upon request.

† Refer to Page 6 for Reference Notes.

UW – Gearmotor Selection Table †

0.25 HP/1750 rpm/56C Frame Motor

(Also use these selections for UW drives with TA bushing. Refer to Falk for Part No.)

Approx Output rpm	Exact Ratio	Actual Output Torque (lb-in)	Service Factor	Overhung Load (lb)	Hollow L.S. Shaft Basic Drive Gearmotor Less Motor Inch Dimensioned		Hollow L.S. Shaft With Drywell Flange Mounted Gearmotor Less Motor Inch Dimensioned	
					Drive Designation	Part No.	Drive Designation	Part No.
11	160.26	1127	3.16	1674	05UWAQ3A160A_A	4761556		
9.3	187.76	1312	2.72	1674	180	4761559		
8.7	201.10	1207	3.96	1674	200	4761562		
7.6	229.81	1369	3.64	1674	225	4761565		
6.7	262.58	1808	1.96	1674	265	4761568		
6.0	291.75	2002	1.76	1674	280	4761571		
5.6	310.18	1817	2.88	1674	315	4761574		
4.8	363.40	2110	2.52	1674	360	4761577		
4.3	402.70	2744	1.28	1674	400	4761580		
3.8	457.66	3098	1.12	1672	450	4761583		
3.4	508.21	2895	1.84	1672	500	4761586		
3.1	564.68	3202	1.68	1672	560	4761589		
2.2	779.42	4349	1.24	1665	800	4761592		
2.0	885.79	4906	1.08	1663	900	4761595		
6.6	265.95	1944	3.92	1784	06UWAQ3A265A_A	4761628		
5.8	299.67	2181	3.52	1775	280	4761631		
4.9	357.32	2195	3.76	1784	360	4761637		
4.4	395.39	2858	2.68	1753	400	4761640		
3.9	449.60	3229	2.36	1737	450	4761643		
3.4	514.75	3086	2.48	1753	500	4761646		
3.0	580.00	3454	2.20	1741	560	4761649		
2.3	765.28	4488	1.72	1708	800	4761652		
2.0	870.00	5063	1.52	1687	900	4761655		
4.2	419.25	3150	3.92	5035	07UWBQ3A450A_A	4761708	07UWXQ3A450A_A	4761778
3.5	499.88	3502	3.28	5035	500	4761712	500	4761782
3.2	547.35	3823	3.00	5035	560	4761716	560	4761786
2.3	747.66	5131	2.20	5035	800	4761720	800	4761790
2.1	838.50	5731	1.96	5035	900	4761724	900	4761794

Motors are available from Rexnord or Rexnord Distributors.

.25 HP/56C Motor Falk Part No. 1940393 Conforms to the following specifications:

C Face motor less base, TEFC, 1750 rpm, 208–230/460 Volts, 3 Phase, 60 Hz, NEMA B, 1.15 Service Factor.

Motors meeting other specifications are available upon request.

† Refer to Page 6 for Reference Notes.

UW – Gearmotor Selection Table †

0.33 HP/1750 rpm/56C Frame Motor

(Also use these selections for UW drives with TA bushing. Refer to Falk for Part No.)

Approx Output rpm	Exact Ratio	Actual Output Torque (lb-in)	Service Factor	Overhung Load (lb)	Hollow L.S. Shaft Basic Drive Gearmotor Less Motor Inch dimensioned	
					Drive Designation	Part No.
204	8.59	86	8.03	453	03UWAQ2A8.0A_A	4760282
151	11.61	116	6.48	453	11.	4760286
133	13.20	131	5.91	453	12.	4760290
117	14.95	147	5.42	451	14.	4760294
107	16.36	144	5.15	453	16.	4760298
91	19.13	188	4.55	451	18.	4760302
85	20.61	202	4.33	451	20.	4760306
79	22.11	192	4.21	451	22.	4760310
70	25.14	217	3.88	451	25.	4760314
61	28.48	244	3.55	451	28.	4760318
52	33.71	324	3.03	450	32.	4760322
48	36.43	307	3.00	450	36.	4760325
45	39.26	330	2.85	450	40.	4760329
38	45.50	432	2.42	448	45.	4760333
33	53.31	502	2.15	448	50.	4761814
31	56.19	462	2.24	448	56.	4760338
27	64.21	524	2.03	448	63.	4760341
23	74.55	694	1.79	445	71.	4760344
21	82.83	769	1.64	445	80.	4760347
20	86.67	693	1.73	445	90.	4760350
17	101.54	806	1.55	445	100	4760353
15	114.33	1046	1.33	442	112	4760356
13	129.94	1182	1.09	440	125	4760359
12	142.00	1101	1.21	441	140	4760362
11	157.78	1213	1.12	440	160	4760365
17	105.36	948	1.42	437	03UWAQ3A100A_A	4761430
15	120.39	1083	1.27	437	118	4761433
13	130.10	984	1.27	437	132	4761436
12	140.21	1063	1.21	437	150	4761440
33	53.31	509	3.61	1771	04UWAQ2A50.A_A	4760428
31	56.19	473	3.58	1771	56.	4760431
27	64.21	535	3.24	1771	63.	4760434
23	74.55	702	2.67	1771	71.	4760437
21	82.83	775	2.24	1771	80.	4760440
20	86.67	709	2.76	1771	90.	4760443
17	101.54	821	2.45	1771	100	4760446
15	114.33	1054	1.45	1771	112	4760449
13	129.94	1190	1.09	1771	125	4760452
12	142.00	1120	1.94	1770	140	4760455
11	157.78	1234	1.79	1771	160	4760458
8.0	217.78	1676	1.42	1770	212	4760461
7.1	247.50	1883	1.09	1771	250	4760464
17	105.36	963	1.91	1771	04UWAQ3A100A_A	4761486
15	120.39	1096	1.67	1771	118	4761489
13	130.10	1010	2.00	1771	132	4761492
12	140.21	1085	1.91	1771	150	4761496
11	162.50	1463	1.24	1770	160	4761500
9.2	190.38	1708	1.06	1771	180	4761503
8.7	200.68	1526	1.52	1770	200	4761506
7.6	229.32	1735	1.39	1770	225	4761509
5.7	309.52	2301	1.18	1769	315	4761518
4.8	362.64	2676	1.06	1766	360	4761521
16	109.07	1037	3.00	1674	05UWAQ2A112A_A	4761815
14	124.00	1169	2.27	1674	125	4760547
12	142.00	1162	3.91	1674	140	4760550
11	160.00	1299	3.58	1674	160	4760553
8.3	211.11	1686	2.91	1673	212	4760556
7.3	240.00	1898	2.27	1673	250	4760559
17	103.90	980	3.70	1674	05UWAQ3A100A_A	4761542
15	118.73	1115	3.24	1674	118	4761545
13	130.38	1061	3.94	1674	132	4761548
12	140.51	1138	3.76	1674	150	4761552
11	160.26	1487	2.39	1673	160	4761556
9.3	187.76	1732	2.06	1673	180	4761559

Motors are available from Rexnord or Rexnord Distributors.

.33 HP/56C Motor Falk Part No. 1940394 Conforms to the following specifications:

C Face motor less base, TEFC, 1750 rpm, 208–230/460 Volts, 3 Phase, 60 Hz, NEMA B, 1.15 Service Factor.

Motors meeting other specifications are available upon request.

† Refer to Page 6 for Reference Notes.

UW – Gearmotor Selection Table †

0.33 HP/1750 rpm/56C Frame Motor

(Also use these selections for UW drives with TA bushing. Refer to Falk for Part No.)

Approx Output rpm	Exact Ratio	Actual Output Torque (lb-in)	Service Factor	Overhung Load (lb)	Hollow L.S. Shaft Basic Drive Gearmotor Less Motor Inch Dimensioned		Hollow L.S. Shaft With Drywell Flange Mounted Gearmotor Less Motor Inch Dimensioned	
					Drive Designation	Part No.	Drive Designation	Part No.
8.7	201.10	1594	3.00	1673	05UWAQ3A200A_A	4761562		
7.6	229.81	1807	2.76	1673	225	4761565		
6.7	262.58	2386	1.48	1672	265	4761568		
6.0	291.75	2643	1.33	1672	280	4761571		
5.6	310.18	2398	2.18	1672	315	4761574		
4.8	363.40	2785	1.91	1672	360	4761577		
4.3	402.70	3623	0.97	1668	400	4761580		
3.8	457.66	4089	0.85	1668	450	4761583		
3.4	508.21	3821	1.39	1668	500	4761586		
3.1	564.68	4227	1.27	1668	560	4761589		
14	124.00	1235	3.88	1810	06UWAQ2A125A_A	4760638		
7.3	240.00	2010	3.79	1788	250	4760654		
6.6	265.95	2566	2.97	1762	06UWAQ3A265A_A	4761628		
5.8	299.67	2880	2.67	1750	280	4761631		
5.3	328.67	2680	2.85	1767	315	4761634		
4.9	357.32	2898	2.64	1760	360	4761637		
4.4	395.39	3772	2.03	1719	400	4761640		
3.9	449.50	4263	1.79	1699	450	4761643		
3.4	514.75	4074	1.88	1719	500	4761646		
3.0	580.00	4560	1.67	1703	560	4761649		
2.3	765.28	5924	1.30	1657	800	4761652		
2.0	870.00	6683	1.15	1630	900	4761655		
5.5	319.95	3018	3.73	5032	07UWBQ3A315A_A	4761696	07UWXQ3A315A_A	4761766
5.1	341.61	3211	3.52	5031	360	4761700	360	4761770
4.7	373.83	3723	3.30	5030	400	4761704	400	4761774
4.2	419.25	4158	2.97	5030	450	4761708	450	4761778
3.5	499.88	4622	2.48	5028	500	4761712	500	4761782
3.2	547.35	5047	2.27	5028	560	4761716	560	4761786
2.3	747.66	6773	1.67	5021	800	4761720	800	4761790
2.1	838.50	7565	1.48	5021	900	4761724	900	4761794

Motors are available from Rexnord or Rexnord Distributors.

.33 HP/56C Motor
Falk Part No. 1940394
Conforms to the following specifications:

C Face motor less base, TEFC, 1750 rpm, 208-230/460 Volts, 3 Phase, 60 Hz, NEMA B, 1.15 Service Factor.

Motors meeting other specifications are available upon request.

† Refer to Page 6 for Reference Notes.

UW – Gearmotor Selection Table †

0.50 HP/1750 rpm/56C Frame Motor

(Also use these selections for UW drives with TA bushing. Refer to Falk for Part No.)

Approx Output rpm	Exact Ratio	Actual Output Torque (lb-in)	Service Factor	Overhung Load (lb)	Hollow L.S. Shaft Basic Drive Gearmotor Less Motor Inch Dimensioned	
					Drive Designation	Part No.
204	8.59	131	5.30	453	03UWAQ2A8.0A_A	4760282
151	11.61	175	4.28	452	11.	4760286
133	13.20	198	3.90	452	12.	4760290
117	14.95	224	3.58	450	14.	4760294
107	16.36	219	3.40	452	16.	4760298
91	19.13	285	3.00	450	18.	4760302
85	20.61	307	2.86	450	20.	4760306
79	22.11	291	2.78	450	22.	4760310
70	25.14	329	2.56	450	25.	4760314
61	28.48	370	2.34	449	28.	4760318
52	33.71	491	2.00	448	32.	4760322
48	36.43	466	1.98	448	36.	4760325
45	39.26	500	1.88	448	40.	4760329
38	45.50	655	1.60	445	45.	4760333
33	53.31	761	1.42	445	50.	4761814
31	56.19	701	1.48	445	56.	4760338
27	64.21	795	1.34	445	63.	4760341
23	74.55	1052	1.18	440	71.	4760344
21	82.83	1165	1.08	440	80.	4760347
20	86.67	1050	1.14	440	90.	4760350
17	101.54	1222	1.02	440	100	4760353
61	28.48	382	3.76	1771	04UWAQ2A28.A_A	4760410
52	33.71	499	3.32	1771	32.	4760414
48	36.43	478	3.18	1771	36.	4760417
45	39.26	517	3.02	1771	40.	4760421
38	45.50	663	2.68	1771	45.	4760425
33	53.31	771	2.38	1771	50.	4760428
31	56.19	717	2.36	1771	56.	4760431
27	64.21	810	2.14	1771	63.	4760434
23	74.55	1064	1.76	1771	71.	4760437
21	82.83	1174	1.48	1771	80.	4760440
20	86.67	1074	1.82	1771	90.	4760443
17	101.54	1245	1.62	1771	100	4760446
12	142.00	1698	1.28	1769	140	4760455
11	157.78	1870	1.18	1771	160	4760458
17	105.36	1460	1.26	1771	04UWAQ3A100A_A	4761486
15	120.39	1661	1.10	1771	118	4761489
13	130.10	1530	1.32	1770	132	4761492
12	140.21	1645	1.26	1770	150	4761496
24	73.37	1076	3.02	1673	05UWAQ2A71.A_A	4760533
21	82.67	1206	2.72	1673	80.	4760536
19	90.67	1161	3.58	1673	90.	4760539
18	98.57	1254	3.38	1673	100	4760542
16	109.07	1571	1.98	1674	112	4761815
14	124.00	1772	1.50	1674	125	4760547
12	142.00	1761	2.58	1672	140	4760550
11	160.00	1969	2.36	1672	160	4760553
8.3	211.11	2555	1.92	1671	212	4760556
7.3	240.00	2876	1.50	1670	250	4760559
17	103.90	1486	2.44	1673	05UWAQ3A100A_A	4761542
15	118.73	1690	2.14	1674	118	4761545
13	130.38	1608	2.60	1672	132	4761548
12	140.51	1724	2.48	1672	150	4761552
11	160.26	2254	1.58	1671	160	4761556
9.3	187.76	2625	1.36	1671	180	4761559
8.7	201.10	2415	1.98	1671	200	4761562
7.6	229.81	2738	1.82	1671	225	4761565

Motors are available from Rexnord or Rexnord Distributors.

.50 HP/56C Motor Falk Part No. 1940395 Conforms to the following specifications:

C Face motor less base, TEFC, 1750 rpm, 208–230/460 Volts, 3 Phase, 60 Hz, NEMA B, 1.15 Service Factor.

Motors meeting other specifications are available upon request.

† Refer to Page 6 for Reference Notes.

UW – Gearmotor Selection Table †

0.50 HP/1750 rpm/56C Frame Motor

(Also use these selections for UW drives with TA bushing. Refer to Falk for Part No.)

Approx Output rpm	Exact Ratio	Actual Output Torque (lb-in)	Service Factor	Overhung Load (lb)	Hollow L.S. Shaft Basic Drive Gearmotor Less Motor Inch Dimensioned		Hollow L.S. Shaft With Drywell Flange Mounted Gearmotor Less Motor Inch Dimensioned	
					Drive Designation	Part No.	Drive Designation	Part No.
5.6	310.18	3634	1.44	1668	05UWAQ3A315A_A	4761574		
4.8	363.40	4220	1.26	1668	360	4761577		
16	110.57	1680	4.02	1795	06UWAQ2A112A_A	4760634		
14	124.00	1872	2.56	1787	125	4760638		
12	143.08	1888	4.02	1793	140	4760642		
11	156.67	2062	3.72	1786	160	4760646		
8.2	214.00	2736	2.78	1762	212	4760650		
7.3	240.00	3046	2.50	1753	250	4760654		
13	130.00	1702	4.06	1799	06UWAQ3A132A_A	4761606		
12	147.69	1921	3.74	1792	150	4761610		
10	169.81	2522	3.02	1760	160	4761614		
9.5	184.62	2725	2.78	1753	180	4761617		
8.7	201.02	2569	2.98	1769	200	4761620		
7.7	228.38	2898	2.64	1757	225	4761624		
6.6	265.95	3889	1.96	1715	265	4761628		
5.8	299.67	4363	1.76	1696	280	4761631		
5.3	328.67	4061	1.88	1719	315	4761634		
4.9	357.32	4391	1.74	1708	360	4761637		
4.4	395.39	5716	1.34	1648	400	4761640		
3.9	449.50	6459	1.18	1617	450	4761643		
3.4	514.75	6172	1.24	1646	500	4761646		
3.0	580.00	6909	1.10	1621	560	4761649		
8.4	208.65	3033	3.42	5031	07UWBQ2A212A_A	4760769	07UWXQ2A212A_A	4761156
7.5	231.83	3376	3.16	5026	250	4760774	250	4761161
9.0	194.65	2830	3.66	5029	07UWBQ3A200A_A	4761680	07UWXQ3A200A_A	4761750
7.7	226.39	3264	3.24	5029	225	4761684	225	4761754
7.0	249.94	3822	3.22	5026	265	4761688	265	4761758
6.4	273.68	4169	2.94	5026	280	4761692	280	4761762
5.5	319.95	4573	2.46	5026	315	4761696	315	4761766
5.1	341.61	4865	2.32	5022	360	4761700	360	4761770
4.7	373.83	5641	2.18	5020	400	4761704	400	4761774
4.2	419.25	6300	1.96	5020	450	4761708	450	4761778
3.5	499.88	7004	1.64	5013	500	4761712	500	4761782
3.2	547.35	7647	1.50	5013	560	4761716	560	4761786
2.3	747.66	10263	1.10	4990	800	4761720	800	4761790

Motors are available from Rexnord or Rexnord Distributors.

.50 HP/56C Motor
Falk Part No. 1940395
Conforms to the following specifications:

C Face motor less base, TEFC, 1750 rpm, 208-230/460 Volts, 3 Phase, 60 Hz, NEMA B, 1.15 Service Factor.

Motors meeting other specifications are available upon request.

† Refer to Page 6 for Reference Notes.

UW – Gearmotor Selection Table †

0.75 HP/1750 rpm/56C Frame Motor

(Also use these selections for UW drives with TA bushing. Refer to Falk for Part No.)

Approx Output rpm	Exact Ratio	Actual Output Torque (lb-in)	Service Factor	Overhung Load (lb)	Hollow L.S. Shaft Basic Drive Gearmotor Less Motor Inch dimensioned	
					Drive Designation	Part No.
204	8.59	197	3.53	452	03UWAQ2A8.0A_A	4760282
151	11.61	263	2.85	451	11.	4760286
133	13.20	297	2.60	451	12.	4760290
117	14.95	336	2.39	449	14.	4760294
107	16.36	328	2.27	450	16.	4760298
91	19.13	427	2.00	449	18.	4760302
85	20.61	460	1.91	448	20.	4760306
79	22.11	436	1.85	448	22.	4760310
70	25.14	493	1.71	448	25.	4760314
61	28.48	556	1.56	447	28.	4760318
52	33.71	736	1.33	445	32.	4760322
48	36.43	699	1.32	445	36.	4760325
45	39.26	750	1.25	445	40.	4760329
38	45.50	982	1.07	442	45.	4760333
117	14.95	344	3.99	1771	04UWAQ2A14.A_A	4760386
107	16.36	338	3.63	1771	16.	4760390
91	19.13	437	3.33	1771	18.	4760394
85	20.61	468	3.16	1771	20.	4760398
79	22.11	450	2.97	1771	22.	4760402
70	25.14	508	2.72	1771	25.	4760406
61	28.48	573	2.51	1771	28.	4760410
52	33.71	749	2.21	1771	32.	4760414
48	36.43	717	2.12	1771	36.	4760417
45	39.26	775	2.01	1771	40.	4760421
38	45.50	995	1.79	1771	45.	4760425
33	53.31	1157	1.59	1770	50.	4760428
31	56.19	1076	1.57	1771	56.	4760431
27	64.21	1216	1.43	1771	63.	4760434
23	74.55	1597	1.17	1771	71.	4760437
20	86.67	1612	1.21	1771	90.	4760443
17	101.54	1867	1.08	1769	100	4760446
54	32.55	740	3.85	1674	05UWAQ2A32.A_A	4760507
37	46.84	1050	2.95	1673	45.	4760519
34	50.93	1137	2.77	1673	50.	4760522
32	55.45	1102	3.28	1673	56.	4760525
28	63.00	1240	3.00	1674	63.	4760529
24	73.37	1614	2.01	1672	71.	4760533
21	82.67	1809	1.81	1673	80.	4760536
19	90.67	1742	2.39	1672	90.	4760539
18	98.57	1881	2.25	1671	100	4760542
16	109.07	2357	1.32	1673	112	4761815
14	124.00	2658	1.00	1674	125	4760547
12	142.00	2641	1.72	1670	140	4760550
11	160.00	2953	1.57	1670	160	4760553
8.3	211.11	3833	1.28	1667	212	4760556
7.3	240.00	4314	1.00	1665	250	4760559
17	103.90	2229	1.63	1671	05UWAQ3A100A_A	4761542
15	118.73	2536	1.43	1673	118	4761545
13	130.38	2412	1.73	1670	132	4761548
12	140.51	2586	1.65	1670	150	4761552
11	160.26	3381	1.05	1668	160	4761556
8.7	201.10	3623	1.32	1667	200	4761562
7.6	229.81	4108	1.21	1668	225	4761565

Motors are available from Rexnord or Rexnord Distributors

.75 HP/56C Motor Falk Part No. 1940396 Conforms to the following specifications:

C Face motor less base, TEFC, 1750 rpm, 208-230/460 Volts, 3 Phase, 60 Hz, NEMA B, 1.15 Service Factor.

Motors meeting other specifications are available upon request.

† Refer to Page 6 for Reference Notes.

UW – Gearmotor Selection Table †

0.75 HP/1750 rpm/56C Frame Motor

(Also use these selections for UW drives with TA bushing. Refer to Falk for Part No.)

Approx Output rpm	Exact Ratio	Actual Output Torque (lb-in)	Service Factor	Overhung Load (lb)	Hollow L.S. Shaft Basic Drive Gearmotor Less Motor Inch Dimensioned		Hollow L.S. Shaft With Drywell Flange Mounted Gearmotor Less Motor Inch Dimensioned	
					Drive Designation	Part No.	Drive Designation	Part No.
24	73.92	1713	3.77	1793	06UWAQ2A71.A_A	4760618		
22	80.94	1869	3.48	1786	80.	4760622		
19	91.58	1875	3.73	1792	90.	4760626		
18	97.78	1985	3.55	1789	100	4760630		
16	110.57	2520	2.68	1765	112	4760634		
14	124.00	2808	1.71	1754	125	4760638		
12	143.08	2832	2.68	1761	140	4760642		
11	156.67	3093	2.48	1751	160	4760646		
8.2	214.00	4104	1.85	1715	212	4760650		
7.3	240.00	4570	1.67	1700	250	4760654		
17	103.86	2355	3.12	1768	06UWAQ3A100A_A	4761598		
15	117.99	3675	2.85	1759	118	4761602		
13	130.00	3554	2.71	1770	132	4761606		
12	147.69	3882	2.49	1759	150	4761610		
10	169.81	3783	2.01	1714	160	4761614		
9.5	184.62	4087	1.85	1702	180	4761617		
8.7	201.02	3854	1.99	1725	200	4761620		
7.7	228.38	4347	1.76	1707	225	4761624		
6.6	265.95	5833	1.31	1645	265	4761628		
5.8	299.67	6545	1.17	1617	280	4761631		
5.3	328.67	6091	1.25	1650	315	4761634		
4.9	357.32	6586	1.16	1632	360	4761637		
18	99.79	2276	4.03	5031	07UWBQ2A100A_A	4760744	07UWXQ2A100A_A	4761131
17	104.32	2459	3.33	5031	112	4760749	112	4761136
15	115.92	2726	3.00	5027	125	4760754	125	4761141
13	138.00	3099	3.13	5027	140	4760759	140	4761146
12	151.13	3368	2.92	5029	160	4760764	160	4761151
8.4	208.65	4550	2.28	5026	212	4760769	212	4761156
7.5	231.83	5064	2.11	5017	250	4760774	250	4761161
11	159.98	3718	3.31	5023	07UWBQ3A160A_A	4761672	07UWXQ3A160A_A	4761742
10	170.81	3976	3.11	5023	180	4761676	180	4761746
9.0	194.65	4246	2.44	5022	200	4761680	200	4761750
7.7	226.39	4897	2.16	5022	225	4761684	225	4761754
7.0	249.94	5733	2.15	5016	265	4761688	265	4761758
6.4	273.68	6254	1.96	5017	280	4761692	280	4761762
5.5	319.95	6860	1.64	5017	315	4761696	315	4761766
5.1	341.61	7298	1.55	5008	360	4761700	360	4761770
4.7	373.83	8462	1.45	5005	400	4761704	400	4761774
4.2	419.25	9450	1.31	5005	450	4761708	450	4761778
3.5	499.88	10506	1.09	4990	500	4761712	500	4761782
3.2	547.35	11470	1.00	4990	560	4761716	560	4761786

Motors are available from Rexnord or Rexnord Distributors

.75 HP/56C Motor
Falk Part No. 1940396
Conforms to the following specifications:

C Face motor less base, TEFC, 1750 rpm, 208-230/460 Volts, 3 Phase, 60 Hz, NEMA B, 1.15 Service Factor.

Motors meeting other specifications are available upon request.

† Refer to Page 6 for Reference Notes.

UW – Gearmotor Selection Table †

1.0 HP/1750 rpm/143TC Frame Motor

(Also use these selections for UW drives with TA bushing. Refer to Falk for Part No.)

Approx Output rpm	Exact Ratio	Actual Output Torque (lb-in)	Service Factor	Overhung Load (lb)	Hollow L.S. Shaft Basic Drive Gearmotor Less Motor Inch Dimensioned	
					Drive Designation	Part No.
204	8.59	263	2.65	451	03UWAQ2A8.0A_B	4760283
151	11.61	351	2.14	450	11.	4760287
133	13.20	397	1.95	450	12.	4760291
117	14.95	448	1.79	448	14.	4760295
107	16.36	438	1.70	449	16.	4760299
91	19.13	570	1.50	447	18.	4760303
85	20.61	614	1.43	446	20.	4760307
79	22.11	582	1.39	446	22.	4760311
70	25.14	658	1.28	446	25.	4760315
61	28.48	741	1.17	445	28.	4760319
52	33.71	982	1.00	442	32.	4760323
151	11.61	359	3.57	1771	04UWAQ2A11.A_B	4760379
133	13.20	406	3.25	1771	12.	4760383
117	14.95	459	2.99	1771	14.	4760387
107	16.36	451	2.72	1771	16.	4760391
91	19.13	583	2.50	1771	18.	4760395
85	20.61	624	2.37	1771	20.	4760399
79	22.11	600	2.23	1771	22.	4760403
70	25.14	678	2.04	1771	25.	4760407
61	28.48	765	1.88	1771	28.	4760411
52	33.71	998	1.66	1771	32.	4760415
48	36.43	956	1.59	1771	36.	4760418
45	39.26	1034	1.51	1771	40.	4760422
38	45.50	1327	1.34	1771	45.	4760426
33	53.31	1543	1.19	1770	50.	4760429
31	56.19	1435	1.18	1771	56.	4760432
27	64.21	1621	1.07	1771	63.	4760435
83	21.05	648	3.82	1674	05UWAQ2A20.A_B	4760492
79	22.56	798	4.71	1673	22.	4760496
70	24.86	901	4.40	1673	25.	4760500
62	28.24	785	4.02	1673	28.	4760504
54	32.55	987	2.89	1674	32.	4760508
49	35.86	981	3.39	1674	36.	4760512
43	40.74	1105	3.07	1674	40.	4760516
37	46.84	1400	2.21	1672	45.	4760520
34	50.93	1516	2.08	1672	50.	4760523
32	55.45	1470	2.46	1672	56.	4760526
28	63.00	1653	2.25	1673	63.	4760530
24	73.37	2152	1.51	1670	71.	4760534
21	82.67	2413	1.36	1672	80.	4760537
19	90.67	2323	1.79	1670	90.	4760540
18	98.57	2508	1.69	1670	100	4760543
12	142.00	3522	1.29	1668	140	4760551
11	160.00	3938	1.18	1668	160	4760554
17	103.90	2972	1.22	1669	05UWAQ3A100A_B	4761543
15	118.73	3381	1.07	1672	118	4761546
13	130.38	3216	1.30	1668	132	4761549
12	140.51	3449	1.24	1668	150	4761553
37	47.32	1488	3.95	1801	06UWAQ2A45.A_B	4760603
35	50.52	1585	3.79	1798	50.	4760607
31	55.71	1570	3.85	1801	56.	4760611
27	64.80	1806	3.46	1795	63.	4760615
24	73.92	2284	2.83	1773	71.	4760619
22	80.94	2492	2.61	1764	80.	4760623
19	91.58	2501	2.80	1771	90.	4760627
18	97.78	2647	2.66	1767	100	4760631
16	110.57	3361	2.01	1735	112	4760635
14	124.00	3744	1.28	1720	125	4760639
12	143.08	3776	2.01	1728	140	4760643
11	156.67	4124	1.86	1716	160	4760647
8.2	214.00	5472	1.39	1667	212	4760651
7.3	240.00	6093	1.25	1648	250	4760655

Motors are available from Rexnord or Rexnord Distributors

1.0 HP/143TC Motor Falk Part No. 1940397 Conforms to the following specifications:

C Face motor less base, TEFC, 1750 rpm, 208–230/460 Volts, 3 Phase, 60 Hz, NEMA B, 1.15 Service Factor.

Motors meeting other specifications are available upon request.

† Refer to Page 6 for Reference Notes.

UW – Gearmotor Selection Table †

1.0 HP/1750 rpm/143TC Frame Motor

(Also use these selections for UW drives with TA bushing. Refer to Falk for Part No.)

Approx Output rpm	Exact Ratio	Actual Output Torque (lb-in)	Service Factor	Overhung Load (lb)	Hollow L.S. Shaft Basic Drive Gearmotor Less Motor Inch Dimensioned		Hollow L.S. Shaft With Drywell Flange Mounted Gearmotor Less Motor Inch Dimensioned	
					Drive Designation	Part No.	Drive Designation	Part No.
17	103.86	3141	2.34	1793	06UWAQ3A100A_B	4761599		
15	117.99	3566	2.14	1727	118	4761603		
13	130.00	3405	2.03	1741	132	4761607		
12	147.69	3843	1.87	1727	150	4761611		
10	169.81	5044	1.51	1667	160	4761615		
9.5	184.62	5450	1.39	1650	180	4761618		
8.7	201.02	5139	1.49	1681	200	4761621		
7.7	228.38	5796	1.32	1657	225	4761625		
25	69.00	2210	3.56	5028	07UWBQ2A71.A_B	4760730	07UWXQ2A71.A_B	4761117
23	75.56	2413	3.29	5028	80.	4760735	80.	4761122
20	88.26	2694	3.33	5029	90.	4760740	90.	4761127
18	99.79	3035	3.02	5029	100	4760745	100	4761132
17	104.32	3279	2.50	5029	112	4760750	112	4761137
15	115.92	3634	2.25	5023	125	4760755	125	4761142
13	138.00	4132	2.35	5023	140	4760760	140	4761147
12	151.13	4490	2.19	5026	160	4760765	160	4761152
8.4	208.65	6067	1.71	5022	212	4760770	212	4761157
7.5	231.83	6752	1.58	5008	250	4760775	250	4761162
18	97.33	3067	4.01	5025	07UWBQ3A100A_B	4761659	07UWXQ3A100A_B	4761729
15	113.20	3555	3.46	5023	118	4761663	118	4761733
11	159.98	4958	2.48	5017	160	4761673	160	4761743
10	170.81	5302	2.33	5017	180	4761677	180	4761747
9.0	194.65	5661	1.83	5016	200	4761681	200	4761751
7.7	226.39	6529	1.62	5016	225	4761685	225	4761755
7.0	249.94	7644	1.61	5006	265	4761689	265	4761759
6.4	273.68	8339	1.47	5008	280	4761693	280	4761763
5.5	319.95	9147	1.23	5008	315	4761697	315	4761767
5.1	341.61	9730	1.16	4995	360	4761701	360	4761771
4.7	373.83	11282	1.09	4990	400	4761705	400	4761775
8.5	204.75	6084	3.53	6468	08UWBQ2A212A_B	4760900	08UWXQ2A212A_B	4761287
7.4	235.77	6951	3.17	6468	250	4760906	250	4761293

Motors are available from Rexnord or Rexnord Distributors

1.0 HP/143TC Motor Falk Part No. 1940397 Conforms to the following specifications:

C Face motor less base, TEFC, 1750 rpm, 208–230/460 Volts, 3 Phase, 60 Hz, NEMA B, 1.15 Service Factor.

Motors meeting other specifications are available upon request.

† Refer to Page 6 for Reference Notes.

UW – Gearmotor Selection Table †

1.5 HP/1750 rpm/145TC Frame Motor

(Also use these selections for UW drives with TA bushing. Refer to Falk for Part No.)

Approx Output rpm	Exact Ratio	Actual Output Torque (lb-in)	Service Factor	Overhung Load (lb)	Hollow L.S. Shaft Basic Drive Gearmotor Less Motor Inch Dimensioned	
					Drive Designation	Part No.
204	8.59	394	1.77	450	03UWAQ2A8.0A_B	4760283
151	11.61	527	1.43	447	11.	4760287
133	13.20	595	1.30	447	12.	4760291
117	14.95	672	1.19	445	14.	4760295
107	16.36	657	1.13	446	16.	4760299
91	19.13	855	1.00	445	18.	4760303
204	8.59	402	2.93	1771	04UWAQ2A8.0A_B	4760375
151	11.61	539	2.38	1771	11.	4760379
133	13.20	610	2.17	1771	12.	4760383
117	14.95	689	1.99	1771	14.	4760387
107	16.36	677	1.81	1771	16.	4760391
91	19.13	874	1.67	1771	18.	4760395
85	20.61	936	1.58	1771	20.	4760399
79	22.11	901	1.49	1771	22.	4760403
70	25.14	1017	1.36	1771	25.	4760407
61	28.48	1147	1.25	1771	28.	4760411
52	33.71	1498	1.11	1771	32.	4760415
48	36.43	1434	1.06	1771	36.	4760418
45	39.26	1551	1.01	1771	40.	4760422
150	11.66	553	3.61	1674	05UWAQ2A11.A_B	4760472
136	12.85	604	3.41	1674	12.	4760476
120	14.59	684	3.17	1674	14.	4760480
109	16.09	697	3.95	1674	16.	4760484
94	18.53	860	2.75	1674	18.	4760488
83	21.05	972	2.55	1674	20.	4760492
78	22.56	958	3.14	1674	22.	4760496
70	24.86	1047	2.93	1673	25.	4760500
62	28.24	1178	2.68	1673	28.	4760504
54	32.55	1480	1.93	1673	32.	4760508
49	35.86	1472	2.26	1673	36.	4760512
43	40.74	1657	2.05	1673	40.	4760516
37	46.84	2100	1.47	1671	45.	4760520
34	50.93	2274	1.39	1670	50.	4760523
32	55.45	2205	1.64	1670	56.	4760526
28	63.00	2480	1.50	1673	63.	4760530
24	73.37	3228	1.01	1668	71.	4760534
19	90.67	3485	1.19	1668	90.	4760540
18	98.57	3762	1.13	1666	100	4760543
52	33.48	1600	3.29	1797	06UWAQ2A32.A_B	4760593
37	47.32	2233	2.63	1774	45.	4760603
35	50.52	2377	2.53	1770	50.	4760607
31	55.71	2355	2.57	1775	56.	4760611
27	64.80	2709	2.31	1764	63.	4760615
24	73.92	3427	1.89	1733	71.	4760619
22	80.94	3739	1.74	1720	80.	4760623
19	91.58	3751	1.87	1730	90.	4760627
18	97.78	3971	1.77	1722	100	4760631
16	110.57	5041	1.34	1675	112	4760635
12	143.08	5664	1.34	1664	140	4760643
11	156.67	6186	1.24	1647	160	4760647

Motors are available from Rexnord or Rexnord Distributors

1.5 HP/145TC Motor
Falk Part No. 1940398
Conforms to the following specifications:

C Face motor less base, TEFC, 1750 rpm, 208-230/460 Volts, 3 Phase, 60 Hz, NEMA B, 1.15 Service Factor.

Motors meeting other specifications are available upon request.

† Refer to Page 6 for Reference Notes.

UW – Gearmotor Selection Table †

1.5 HP/1750 rpm/145TC Frame Motor

(Also use these selections for UW drives with TA bushing. Refer to Falk for Part No.)

Approx Output rpm	Exact Ratio	Actual Output Torque (lb-in)	Service Factor	Overhung Load (lb)	Hollow L.S. Shaft Basic Drive Gearmotor Less Motor Inch Dimensioned		Hollow L.S. Shaft With Drywell Flange Mounted Gearmotor Less Motor Inch Dimensioned	
					Drive Designation	Part No.	Drive Designation	Part No.
17	103.86	4711	1.56	1682	06UWAQ3A100A_B	4761599		
15	117.99	5350	1.43	1664	118	4761603		
13	130.00	5108	1.35	1684	132	4761607		
12	147.69	5765	1.25	1661	150	4761611		
10	169.81	7567	1.01	1574	160	4761615		
40	44.13	2152	3.43	5027	07UWBQ2A45.A_B	4760710	07UWXQ2A45.A_B	4761097
35	49.90	2423	3.08	5027	50.	4760715	50.	4761102
33	53.63	2508	3.27	5029	56.	4760720	56.	4761107
28	61.62	2863	2.94	5029	63.	4760725	63.	4761112
25	69.00	3316	2.37	5023	71.	4760730	71.	4761117
23	75.56	3619	2.19	5023	80.	4760735	80.	4761122
20	88.26	4041	2.22	5025	90.	4760740	90.	4761127
18	99.79	4553	2.01	5025	100	4760745	100	4761132
17	104.32	4919	1.67	5025	112	4760750	112	4761137
15	115.92	5452	1.50	5015	125	4760755	125	4761142
13	138.00	6198	1.57	5015	140	4760760	140	4761147
12	151.13	6736	1.46	5019	160	4760765	160	4761152
8.4	208.65	9101	1.14	5013	212	4760770	212	4761157
7.5	231.83	10129	1.05	4990	250	4760775	250	4761162
18	97.33	4601	2.67	5017	07UWBQ3A100A_B	4761659	07UWXQ3A100A_B	4761729
15	113.20	5333	2.31	5015	118	4761663	118	4761733
11	159.98	7437	1.65	5005	160	4761673	160	4761743
10	170.81	7953	1.55	5005	180	4761677	180	4761747
9.0	194.65	8492	1.22	5003	200	4761681	200	4761751
7.7	226.39	9794	1.08	5003	225	4761685	225	4761755
7.0	249.94	11466	1.07	4987	265	4761689	265	4761759
15	117.89	5602	3.94	6462	08UWBQ2A125A_B	4760882	08UWXQ2A125A_B	4761268
13	139.29	6309	3.17	6462	140	4760888	140	4761274
11	153.00	6908	2.95	6462	160	4760894	160	4761280
8.5	204.75	9126	2.35	6464	212	4760900	212	4761286
7.4	235.77	10426	2.11	6464	250	4760906	250	4761292

Motors are available from Rexnord or Rexnord Distributors

1.5 HP/145TC Motor Falk Part No. 1940398 Conforms to the following specifications:

C Face motor less base, TEFC, 1750 rpm, 208–230/460 Volts, 3 Phase, 60 Hz, NEMA B, 1.15 Service Factor.

Motors meeting other specifications are available upon request.

† Refer to Page 6 for Reference Notes.

UW – Gearmotor Selection Table †

2.0 HP/1750 rpm/145TC Frame Motor

(Also use these selections for UW drives with TA bushing. Refer to Falk for Part No.)

Approx Output rpm	Exact Ratio	Actual Output Torque (lb-in)	Service Factor	Overhung Load (lb)	Hollow L.S. Shaft Basic Drive Gearmotor Less Motor Inch Dimensioned	
					Drive Designation	Part No.
204	8.59	526	1.33	448	03UWAQ2A8.0A_B	4760283
151	11.61	703	1.07	445	11.	4760287
204	8.59	536	2.20	1771	04UWAQ2A8.0A_B	4760375
151	11.61	719	1.79	1771	11.	4760379
133	13.20	813	1.63	1771	12.	4760383
117	14.95	918	1.50	1771	14.	4760387
107	16.36	903	1.36	1771	16.	4760391
91	19.13	1166	1.25	1771	18.	4760395
85	20.61	1248	1.19	1771	20.	4760399
79	22.11	1201	1.12	1771	22.	4760403
70	25.14	1356	1.02	1771	25.	4760407
211	8.31	530	3.27	1674	05UWAQ2A8.0A_B	4760468
150	11.66	737	2.71	1674	11.	4760472
136	12.85	806	2.56	1674	12.	4760476
120	14.59	912	2.38	1674	14.	4760480
109	16.09	930	2.96	1674	16.	4760484
94	18.53	1147	2.07	1673	18.	4760488
83	21.05	1296	1.91	1674	20.	4760492
78	22.56	1278	2.36	1673	22.	4760496
70	24.86	1396	2.20	1673	25.	4760500
62	28.24	1571	2.01	1672	28.	4760504
54	32.55	1974	1.45	1673	32.	4760508
49	35.86	1963	1.70	1673	36.	4760512
43	40.74	2210	1.54	1673	40.	4760516
37	46.84	2800	1.11	1670	45.	4760520
34	50.93	3032	1.04	1669	50.	4760523
32	55.45	2940	1.23	1669	56.	4760526
28	63.00	3307	1.13	1672	63.	4760530
52	33.48	2134	2.47	1778	06UWAQ2A32.A_B	4760593
37	47.32	2977	1.98	1748	45.	4760603
35	50.52	3170	1.90	1741	50.	4760607
31	55.71	3140	1.93	1749	56.	4760611
27	64.80	3612	1.73	1733	63.	4760615
24	73.92	4569	1.42	1692	71.	4760619
22	80.94	4985	1.31	1677	80.	4760623
19	91.58	5002	1.40	1688	90.	4760627
18	97.78	5295	1.33	1677	100	4760631
16	110.57	6722	1.01	1616	112	4760635

Motors are available from Rexnord or Rexnord Distributors.

2.0 HP/145TC Motor Falk Part No. 1940399 Conforms to the following specifications:

C Face motor less base, TEFC, 1750 rpm, 208-230/460 Volts, 3 Phase, 60 Hz, NEMA B, 1.15 Service Factor.

Motors meeting other specifications are available upon request.

† Refer to Page 6 for Reference Notes.

UW – Gearmotor Selection Table †

2.0 HP/1750 rpm/145TC Frame Motor

(Also use these selections for UW drives with TA bushing. Refer to Falk for Part No.)

Approx Output rpm	Exact Ratio	Actual Output Torque (lb-in)	Service Factor	Overhung Load (lb)	Hollow L.S. Shaft Basic Drive Gearmotor Less Motor Inch Dimensioned		Hollow L.S. Shaft With Drywell Flange Mounted Gearmotor Less Motor Inch Dimensioned	
					Drive Designation	Part No.	Drive Designation	Part No.
17	103.86	6282	1.17	1625	06UWAQ3A100A_B	4761599		
15	117.99	7133	1.07	1600	118	4761603		
13	130.00	6810	1.02	1627	132	4761607		
57	30.81	2022	3.35	5027	07UWBQ2A32.A_B	4760697	07UWXQ2A32.A_B	4761084
40	44.13	2870	2.58	5024	45.	4760710	45.	4761097
35	49.90	3231	2.31	5024	50.	4760715	50.	4761102
33	53.63	3344	2.46	5027	56.	4760720	56.	4761107
28	61.62	3817	2.21	5027	63.	4760725	63.	4761112
25	69.00	4421	1.78	5019	71.	4760730	71.	4761117
23	75.56	4826	1.65	5019	80.	4760735	80.	4761122
20	88.26	5388	1.67	5021	90.	4760740	90.	4761127
18	99.79	6070	1.51	5021	100	4760745	100	4761132
17	104.32	6559	1.25	5021	112	4760750	112	4761137
15	115.92	7269	1.13	5007	125	4760755	125	4761142
13	138.00	8264	1.18	5007	140	4760760	140	4761147
12	151.13	8981	1.10	5013	160	4760765	160	4761152
18	97.33	6135	2.01	5010	07UWBQ3A100A_B	4761659	07UWXQ3A100A_B	4761729
15	113.20	7110	1.73	5007	118	4761663	118	4761733
11	159.98	9916	1.24	4992	160	4761673	160	4761743
10	170.81	10604	1.17	4992	180	4761677	180	4761747
20	87.29	5409	3.43	6469	08UWBQ2A90.A_B	4760864	08UWXQ2A90.A_B	4761251
18	98.53	6060	3.11	6463	100	4760870	100	4761257
17	102.38	6534	3.62	6463	112	4760876	112	4761263
15	117.89	7469	2.96	6458	125	4760882	125	4761269
13	139.29	8412	2.38	6457	140	4760888	140	4761275
11	153.00	9211	2.22	6457	160	4760894	160	4761281
8.5	204.75	12169	1.77	6460	212	4760900	212	4761287
7.4	235.77	13902	1.59	6460	250	4760906	250	4761293

Motors are available from Rexnord or Rexnord Distributors.

2.0 HP/145TC Motor Falk Part No. 1940399 Conforms to the following specifications:

C Face motor less base, TEFC, 1750 rpm, 208-230/460 Volts, 3 Phase, 60 Hz, NEMA B, 1.15 Service Factor.

Motors meeting other specifications are available upon request.

† Refer to Page 6 for Reference Notes.

UW – Gearmotor Selection Table †

3.0 HP/1750 rpm/182TC Frame Motor

(Also use these selections for UW drives with TA bushing. Refer to Falk for Part No.)

Approx Output rpm	Exact Ratio	Actual Output Torque (lb-in)	Service Factor	Overhung Load (lb)	Hollow L.S. Shaft Basic Drive Gearmotor Less Motor Inch Dimensioned	
					Drive Designation	Part No.
204	8.59	804	1.46	1771	04UWAQ2A8.0A_C	4760376
151	11.61	1079	1.19	1771	11.	4760380
133	13.20	1220	1.08	1771	12.	4760384
117	14.95	1378	1.00	1771	14.	4760388
211	8.31	796	2.18	1674	05UWAQ2A8.0A_C	4760469
150	11.66	1106	1.80	1674	11.	4760473
136	12.85	1209	1.71	1674	12.	4760477
120	14.59	1369	1.58	1674	14.	4760481
109	16.09	1395	1.97	1674	16.	4760485
94	18.53	1721	1.38	1673	18.	4760489
83	21.05	1945	1.27	1674	20.	4760493
78	22.56	1917	1.57	1673	22.	4760497
70	24.86	2094	1.47	1672	25.	4760501
62	28.24	2356	1.34	1670	28.	4760505
49	35.86	2945	1.13	1672	36.	4760513
43	40.74	3315	1.02	1672	40.	4760517
213	8.23	811	3.80	1825	06UWAQ2A8.0A_C	4760562
151	11.57	1137	3.13	1814	11.	4760565
135	12.97	1274	2.92	1809	12.	4760568
120	14.56	1426	2.73	1805	14.	4760571
110	15.93	1435	3.01	1809	16.	4760574
95	18.49	1800	2.37	1791	18.	4760577
83	20.96	2033	2.19	1782	20.	4760580
78	22.40	1994	2.47	1791	22.	4760583
70	25.11	2222	2.31	1785	25.	4760586
62	28.18	2477	2.13	1776	28.	4760589
52	33.48	3201	1.64	1741	32.	4760594
49	35.79	3110	1.79	1755	36.	4760596
43	40.57	3498	1.63	1744	40.	4760599
37	47.32	4466	1.32	1695	45.	4760604
35	50.52	4755	1.26	1685	50.	4760608
31	55.71	4710	1.28	1696	56.	4760612
27	64.80	5418	1.15	1672	63.	4760616

Motors are available from Rexnord or Rexnord Distributors.

3.0 HP/182TC Motor Falk Part No. 1940400 Conforms to the following specifications:

C Face motor less base, TEFC, 1750 rpm, 208–230/460 Volts, 3 Phase, 60 Hz, NEMA B, 1.15 Service Factor.

Motors meeting other specifications are available upon request.

† Refer to Page 6 for Reference Notes.

UW – Gearmotor Selection Table †

3.0 HP/1750 rpm/182TC Frame Motor

(Also use these selections for UW drives with TA bushing. Refer to Falk for Part No.)

Approx Output rpm	Exact Ratio	Actual Output Torque (lb-in)	Service Factor	Overhung Load (lb)	Hollow L.S. Shaft Basic Drive Gearmotor Less Motor Inch Dimensioned		Hollow L.S. Shaft With Drywell Flange Mounted Gearmotor Less Motor Inch Dimensioned	
					Drive Designation	Part No.	Drive Designation	Part No.
111	15.80	1526	4.00	5035	07UWBQ2A16.A_C	4760673	07UWXQ2A16.A_C	4761059
87	20.07	2006	3.83	5035	20.	4760681	20.	4761067
80	21.89	2102	3.17	5035	22.	4760685	22.	4761071
71	24.59	2359	2.92	5035	25.	4760689	25.	4761075
65	27.03	2584	2.73	5035	28.	4760693	28.	4761079
57	30.81	3033	2.23	5023	32.	4760698	32.	4761085
50	35.31	3355	2.24	5035	36.	4760701	36.	4761088
44	40.15	3792	2.04	5035	40.	4760705	40.	4761092
40	44.13	4305	1.72	5018	45.	4760711	45.	4761098
35	49.90	4846	1.54	5018	50.	4760716	50.	4761103
33	53.63	5016	1.64	5022	56.	4760721	56.	4761108
28	61.62	5726	1.47	5022	63.	4760726	63.	4761113
25	69.00	6632	1.19	5009	71.	4760731	71.	4761118
23	75.56	7239	1.10	5009	80.	4760736	80.	4761123
20	88.26	8083	1.11	5013	90.	4760741	90.	4761128
18	99.79	9106	1.01	5013	100	4760746	100	4761133
18	97.33	9203	1.34	4996	07UWBQ3A100A_C	4761660	07UWXQ3A100A_C	4761730
15	113.20	10666	1.15	4990	118	4761664	118	4761734
36	49.26	4833	3.93	6466	08UWBQ2A50.A_C	4760839	08UWXQ2A50.A_C	4761226
32	54.60	5165	3.29	6474	56.	4760843	56.	4761230
28	63.56	5989	2.93	6474	63.	4760847	63.	4761234
25	69.64	6743	3.14	6461	71.	4760853	71.	4761240
23	76.50	7395	2.95	6461	80.	4760859	80.	4761246
20	87.29	8113	2.28	6465	90.	4760865	90.	4761252
18	98.53	9091	2.07	6457	100	4760871	100	4761258
17	102.38	9801	2.41	6457	112	4760877	112	4761264
15	117.89	11204	1.97	6448	125	4760883	125	4761270
13	139.29	12618	1.59	6448	140	4760889	140	4761276
11	153.00	13817	1.48	6448	160	4760895	160	4761282
8.5	204.75	18253	1.18	6452	212	4760901	212	4761288
7.4	235.77	20853	1.06	6452	250	4760907	250	4761294
16	106.17	10291	3.80	7823	09UWBQ2A112A_C	4761007	09UWXQ2A112A_C	4761394
15	119.38	11504	3.43	7823	125	4761013	125	4761400
12	146.23	13295	3.47	7823	140	4761019	140	4761406
11	161.44	14618	3.22	7823	160	4761025	160	4761412
7.9	222.08	19772	2.57	7823	212	4761031	212	4761418
7.0	249.73	22065	2.36	7823	250	4761037	250	4761424
7.8	225.50	20646	3.53	9104	10UWBQ2A212A_C	4763539	10UWXQ2A212A_C	4764099
7.2	242.27	22074	3.33	9104	250	4763545	250	4764105

Motors are available from Rexnord or Rexnord Distributors.

3.0 HP/182TC Motor Falk Part No. 1940400 Conforms to the following specifications:

C Face motor less base, TEFC, 1750 rpm, 208–230/460 Volts, 3 Phase, 60 Hz, NEMA B, 1.15 Service Factor.

Motors meeting other specifications are available upon request.

† Refer to Page 6 for Reference Notes.

UW – Gearmotor Selection Table †

5.0 HP/1750 rpm/184TC Frame Motor

(Also use these selections for UW drives with TA bushing. Refer to Falk for Part No.)

Approx Output rpm	Exact Ratio	Actual Output Torque (lb-in)	Service Factor	Overhung Load (lb)	Hollow L.S. Shaft Basic Drive Gearmotor Less Motor Inch Dimensioned		Hollow L.S. Shaft With Drywell Flange Mounted Gearmotor Less Motor Inch Dimensioned	
					Drive Designation	Part No.	Drive Designation	Part No.
211	8.31	1326	1.31	1674	05UWQAQ2A8.0A_C	4760469		
150	11.66	1844	1.08	1674	11.	4760473		
136	12.85	2015	1.02	1674	12.	4760477		
109	16.09	2325	1.18	1674	16.	4760485		
213	8.23	1352	2.28	1806	06UWQAQ2A8.0A_C	4760562		
151	11.57	1896	1.88	1788	11.	4760565		
135	12.97	2124	1.75	1780	12.	4760568		
120	14.56	2377	1.64	1772	14.	4760571		
110	15.93	2392	1.81	1778	16.	4760574		
95	18.49	3000	1.42	1749	18.	4760577		
83	20.96	3388	1.32	1735	20.	4760580		
78	22.40	3323	1.48	1749	22.	4760583		
70	25.11	3703	1.39	1735	25.	4760586		
62	28.18	4128	1.28	1722	28.	4760589		
49	35.79	5184	1.08	1686	36.	4760596		
222	7.90	1330	4.00	4972	07UWBQ2A8.0A_C	4760658	07UWXQ2A8.0A_C	4761043
160	10.94	1835	3.32	4993	11.	4760662	11.	4761047
142	12.29	2075	3.10	5001	12.	4760666	12.	4761051
129	13.52	2272	2.92	5035	14.	4760669	14.	4761055
111	15.80	2543	2.40	5031	16.	4760673	16.	4761059
99	17.66	2948	2.50	5031	18.	4760677	18.	4761063
87	20.07	3343	2.30	5031	20.	4760681	20.	4761067
80	21.89	3503	1.90	5035	22.	4760685	22.	4761071
71	24.59	3932	1.75	5029	25.	4760689	25.	4761075
65	27.03	4308	1.64	5029	28.	4760693	28.	4761079
57	30.81	5055	1.34	5013	32.	4760698	32.	4761085
50	35.31	5593	1.34	5025	36.	4760701	36.	4761088
44	40.15	6321	1.22	5025	40.	4760705	40.	4761092
40	44.13	7175	1.03	5006	45.	4760711	45.	4761098
79	22.03	3540	3.72	6474	08UWBQ2A22.A_C	4760807	08UWXQ2A22.A_C	4761194
72	24.47	3940	3.48	6471	25.	4760811	25.	4761198
64	27.22	4390	3.26	6471	28.	4760815	28.	4761202
55	31.78	5281	3.12	6469	32.	4760819	32.	4761206
50	35.20	5645	2.74	6470	36.	4760823	36.	4761210
44	39.51	6317	2.52	6470	40.	4760827	40.	4761214
40	43.64	7173	2.56	6460	45.	4760833	45.	4761220
36	49.26	8056	2.36	6460	50.	4760839	50.	4761226
32	54.60	8608	1.97	6468	56.	4760843	56.	4761230
28	63.56	9982	1.76	6468	63.	4760847	63.	4761234
25	69.64	11238	1.89	6452	71.	4760853	71.	4761240
23	76.50	12326	1.77	6452	80.	4760859	80.	4761246
20	87.29	13522	1.37	6459	90.	4760865	90.	4761252
18	98.53	15151	1.24	6445	100	4760871	100	4761258
17	102.38	16335	1.45	6445	112	4760877	112	4761264
15	117.89	18674	1.18	6430	125	4760883	125	4761270
25	69.91	11442	3.26	7815	09UWBQ2A71.A_C	4760983	09UWXQ2A71.A_C	4761370
23	77.18	12584	3.00	7815	80.	4760989	80.	4761376
19	93.18	14517	2.80	7812	90.	4760995	90.	4761382
17	103.53	15966	2.62	7812	100	4761001	100	4761388
16	106.17	17152	2.28	7816	112	4761007	112	4761394
15	119.38	19173	2.06	7810	125	4761013	125	4761400
12	146.23	22159	2.08	7804	140	4761019	140	4761406
11	161.44	24364	1.93	7804	160	4761025	160	4761412
7.9	222.08	32953	1.54	7791	212	4761031	212	4761418
7.0	249.73	36775	1.42	7783	250	4761037	250	4761424
17	101.47	16010	3.94	9098	10UWBQ2A100A_C	4763509	10UWXQ2A100A_C	4764069
15	115.82	18816	3.68	9096	125	4763521	125	4764081
12	144.71	22590	2.98	9094	140	4763527	140	4764087
10	166.73	25829	2.68	9093	160	4763533	160	4764093
7.8	225.50	34410	2.12	9086	212	4763539	212	4764099
7.2	242.27	36790	2.00	9085	250	4763545	250	4764105

Motors are available from Rexnord or Rexnord Distributors.

5.0 HP/184TC Motor Falk Part No. 1940401 Conforms to the following specifications:

C Face motor less base, TEFC, 1750 rpm, 208–230/460 Volts, 3 Phase, 60 Hz, NEMA B, 1.15 Service Factor.

Motors meeting other specifications are available upon request.

† Refer to Page 6 for Reference Notes.

UW – Gearmotor Selection Table †

7.5 HP/1750 rpm/213TC Frame Motor

(Also use these selections for UW drives with TA bushing. Refer to Falk for Part No.)

Approx Output rpm	Exact Ratio	Actual Output Torque (lb-in)	Service Factor	Overhung Load (lb)	Hollow L.S. Shaft Basic Drive Gearmotor Less Motor Inch Dimensioned		Hollow L.S. Shaft With Drywell Flange Mounted Gearmotor Less Motor Inch Dimensioned	
					Drive Designation	Part No.	Drive Designation	Part No.
213	8.23	2028	1.52	1782	06UWAQ2A8.0A_D	4760563		
151	11.57	2844	1.25	1755	11.	4760566		
135	12.97	3186	1.17	1744	12.	4760569		
120	14.56	3566	1.09	1730	14.	4760572		
110	15.93	3589	1.20	1739	16.	4760575		
222	7.90	1995	2.67	4892	07UWBQ2A8.0A_D	4760659	07UWXQ2A8.0A_D	4761044
160	10.94	2753	2.21	4940	11.	4760663	11.	4761048
142	12.29	3113	2.07	4958	12.	4760667	12.	4761052
129	13.52	3409	1.95	5035	14.	4760670	14.	4761056
111	15.80	3815	1.60	5027	16.	4760674	16.	4761060
99	17.66	4423	1.67	5027	18.	4760678	18.	4761064
87	20.07	5015	1.53	5027	20.	4760682	20.	4761068
80	21.89	5255	1.27	5035	22.	4760686	22.	4761072
71	24.59	5898	1.17	5021	25.	4760690	25.	4761076
65	27.03	6462	1.09	5021	28.	4760694	28.	4761080
159	11.01	2784	3.93	6343	08UWBQ2A11.A_D	4760784	08UWXQ2A11.A_D	4761171
143	12.24	3105	3.69	6367	12.	4760788	12.	4761175
129	13.61	3442	3.47	6403	14.	4760792	14.	4761179
113	15.54	3788	3.05	6474	16.	4760796	16.	4761183
99	17.60	4420	2.97	6474	18.	4760800	18.	4761187
89	19.76	4989	2.77	6474	20.	4760804	20.	4761191
79	22.03	5310	2.48	6474	22.	4760808	22.	4761195
72	24.47	5910	2.32	6468	25.	4760812	25.	4761199
64	27.22	6585	2.17	6468	28.	4760816	28.	4761203
55	31.78	7922	2.08	6462	32.	4760820	32.	4761207
50	35.20	8468	1.83	6466	36.	4760824	36.	4761211
44	39.51	9475	1.68	6466	40.	4760828	40.	4761215
40	43.64	10760	1.71	6452	45.	4760834	45.	4761221
36	49.26	12084	1.57	6452	50.	4760840	50.	4761227
32	54.60	12913	1.31	6460	56.	4760844	56.	4761231
28	63.56	14973	1.17	6460	63.	4760848	63.	4761235
25	69.64	16858	1.26	6441	71.	4760854	71.	4761241
23	76.50	18489	1.18	6441	80.	4760860	80.	4761247
39	44.55	11094	3.07	7812	09UWBQ2A45.A_D	4760964	09UWXQ2A45.A_D	4761351
35	49.49	12258	2.87	7814	50.	4760970	50.	4761357
25	69.91	17164	2.17	7805	71.	4760984	71.	4761371
23	77.18	18876	2.00	7805	80.	4760990	80.	4761377
19	93.18	21776	1.87	7798	90.	4760996	90.	4761383
17	103.53	23949	1.75	7798	100	4761002	100	4761389
16	106.17	25728	1.52	7808	112	4761008	112	4761395
15	119.38	28760	1.37	7794	125	4761014	125	4761401
12	146.23	33239	1.39	7780	140	4761020	140	4761407
11	161.44	36547	1.29	7780	160	4761026	160	4761413
25	69.18	17141	3.72	9097	10UWBQ2A71.A_D	4763492	10UWXQ2A71.A_D	4764052
22	79.71	19675	3.27	9093	80.	4763498	80.	4764058
19	91.32	21824	2.85	9095	90.	4763504	90.	4764064
17	101.47	24015	2.63	9090	100	4763510	100	4764070
16	107.80	26413	2.76	9086	112	4763516	112	4764076
15	115.82	28224	2.45	9086	125	4763522	125	4764082
12	144.71	33885	1.99	9080	140	4763528	140	4764088
10	166.73	38744	1.79	9079	160	4763534	160	4764094
7.8	225.50	51615	1.41	9062	212	4763540	212	4764100
7.2	242.27	55185	1.33	9061	250	4763546	250	4764106

Motors are available from Rexnord or Rexnord Distributors.

7.5 HP/213TC Motor Falk Part No. 1940402 Conforms to the following specifications:

C Face motor less base, TEFC, 1750 rpm, 208–230/460 Volts, 3 Phase, 60 Hz, NEMA B, 1.15 Service Factor.

Motors meeting other specifications are available upon request.

† Refer to Page 6 for Reference Notes.

UW – Gearmotor Selection Table †

10 HP/1750 rpm/215TC Frame Motor

(Also use these selections for UW drives with TA bushing. Refer to Falk for Part No.)

Approx Output rpm	Exact Ratio	Actual Output Torque (lb-in)	Service Factor	Overhung Load (lb)	Hollow L.S. Shaft Basic Drive Gearmotor Less Motor Inch Dimensioned		Hollow L.S. Shaft With Drywell Flange Mounted Gearmotor Less Motor Inch Dimensioned	
					Drive Designation	Part No.	Drive Designation	Part No.
222	7.90	2660	2.00	4813	07UWBQ2A8.0A_D	4760659	07UWXQ2A8.0A_D	4761044
160	10.94	3671	1.66	4887	11.	4760663	11.	4761048
142	12.29	4151	1.55	4915	12.	4760667	12.	4761052
129	13.52	4545	1.46	5035	14.	4760670	14.	4761056
111	15.80	5087	1.20	5022	16.	4760674	16.	4761060
99	17.66	5897	1.25	5022	18.	4760678	18.	4761064
87	20.07	6687	1.15	5022	20.	4760682	20.	4761068
225	7.77	2623	3.59	5880	08UWBQ2A8.0A_D	4760780	08UWXQ2A8.0A_D	4761167
159	11.01	3713	2.95	6270	11.	4760784	11.	4761171
143	12.24	4140	2.77	6307	12.	4760788	12.	4761175
129	13.61	4590	2.60	6363	14.	4760792	14.	4761179
113	15.54	5051	2.29	6474	16.	4760796	16.	4761183
99	17.60	5893	2.23	6474	18.	4760800	18.	4761187
89	19.76	6652	2.08	6474	20.	4760804	20.	4761191
79	22.03	7081	1.86	6474	22.	4760808	22.	4761195
72	24.47	7880	1.74	6465	25.	4760812	25.	4761199
64	27.22	8781	1.63	6465	28.	4760816	28.	4761203
55	31.78	10562	1.56	6455	32.	4760820	32.	4761207
50	35.20	11290	1.37	6461	36.	4760824	36.	4761211
44	39.51	12634	1.26	6461	40.	4760828	40.	4761215
40	43.64	14347	1.28	6444	45.	4760834	45.	4761221
36	49.26	16112	1.18	6444	50.	4760840	50.	4761227
39	44.55	14792	2.30	7805	09UWBQ2A45.A_D	4760964	09UWXQ2A45.A_D	4761351
35	49.49	16344	2.15	7809	50.	4760970	50.	4761357
25	69.91	22885	1.63	7795	71.	4760984	71.	4761371
23	77.18	25168	1.50	7795	80.	4760990	80.	4761377
19	93.18	29035	1.40	7784	90.	4760996	90.	4761383
17	103.53	31933	1.31	7784	100	4761002	100	4761389
16	106.17	34304	1.14	7800	112	4761008	112	4761395
36	48.51	16203	3.76	9094	10UWBQ2A50.A_D	4763478	10UWXQ2A50.A_D	4764038
25	69.18	22855	2.79	9093	71.	4763492	71.	4764052
22	79.71	26233	2.45	9087	80.	4763498	80.	4764058
19	91.32	29098	2.14	9090	90.	4763504	90.	4764064
17	101.47	32020	1.97	9083	100	4763510	100	4764070
16	107.80	35217	2.07	9076	112	4763516	112	4764076
15	115.82	37632	1.84	9076	125	4763522	125	4764082
12	144.71	45180	1.49	9067	140	4763528	140	4764088
10	166.73	51659	1.34	9065	160	4763534	160	4764094
7.8	225.50	68821	1.06	9039	212	4763540	212	4764100
7.2	242.27	73580	1.00	9037	250	4763546	250	4764106

Motors are available from Rexnord or Rexnord Distributors.

10 HP/215TC Motor
Falk Part No. 1940403
Conforms to the following specifications:

C Face motor less base,
TEFC, 1750 rpm,
208–230/460 Volts,
3 Phase, 60 Hz,
NEMA B,
1.00 Service Factor.

Motors meeting other specifications are available upon request.

† Refer to Page 6 for Reference Notes.

UW – Gearmotor Selection Table †

15 HP/1750 rpm/254TC Frame Motor

(Also use these selections for UW drives with TA bushing. Refer to Falk for Part No.)

Approx Output rpm	Exact Ratio	Actual Output Torque (lb-in)	Service Factor	Overhung Load (lb)	Hollow L.S. Shaft Basic Drive Gearmotor Less Motor Inch Dimensioned		Hollow L.S. Shaft With Drywell Flange Mounted Gearmotor Less Motor Inch Dimensioned	
					Drive Designation	Part No.	Drive Designation	Part No.
222	7.90	3911	1.33	4654	07UWBQ2A8.0A_E	4760660	07UWXQ2A8.0A_E	4761045
160	10.94	5398	1.11	4781	11.	4760664	11.	4761049
142	12.29	6103	1.03	4829	12.	4760668	12.	4761053
225	7.77	3856	2.39	5761	08UWBQ2A8.0A_E	4760781	08UWXQ2A8.0A_E	4761168
159	11.01	5458	1.97	6125	11.	4760785	11.	4761172
143	12.24	6086	1.85	6188	12.	4760789	12.	4761176
129	13.61	6748	1.73	6284	14.	4760793	14.	4761180
113	15.54	7425	1.53	6474	16.	4760797	16.	4761184
99	17.60	8664	1.49	6474	18.	4760801	18.	4761188
89	19.76	9780	1.39	6474	20.	4760805	20.	4761192
79	22.03	10410	1.24	6474	22.	4760809	22.	4761196
72	24.47	11585	1.16	6458	25.	4760813	25.	4761200
64	27.22	12909	1.09	6458	28.	4760817	28.	4761204
55	31.78	15529	1.04	6442	32.	4760821	32.	4761208
159	10.98	5498	3.59	7823	09UWBQ2A11.A_E	4760915	09UWXQ2A11.A_E	4761302
142	12.30	6152	3.36	7823	12.	4760919	12.	4761306
127	13.81	6899	3.14	7823	14.	4760923	14.	4761310
105	16.68	7967	2.68	7823	16.	4760927	16.	4761314
98	17.79	8865	2.70	7823	18.	4760931	18.	4761318
88	19.88	9913	2.53	7823	20.	4760935	20.	4761322
76	22.96	10959	2.21	7823	22.	4760939	22.	4761326
68	25.73	12230	2.07	7823	25.	4760943	25.	4761330
61	28.89	13735	1.93	7823	28.	4760947	28.	4761334
56	31.43	15528	1.91	7823	32.	4760951	32.	4761338
47	37.22	17559	1.65	7823	36.	4760955	36.	4761342
42	41.59	19573	1.55	7823	40.	4760959	40.	4761346
39	44.55	21747	1.53	7793	45.	4760965	45.	4761352
35	49.49	24028	1.43	7798	50.	4760971	50.	4761358
30	57.66	26948	1.26	7800	56.	4760975	56.	4761362
27	65.74	30591	1.17	7800	63.	4760979	63.	4761366
25	69.91	33646	1.09	7775	71.	4760985	71.	4761372
23	77.18	37001	1.00	7775	80.	4760991	80.	4761378
75	23.23	11259	3.91	9104	10UWBQ2A22.A_E	4763447	10UWXQ2A22.A_E	4764007
69	25.27	12257	3.72	9104	25.	4763451	25.	4764011
61	28.70	13909	3.44	9104	28.	4763455	28.	4764015
55	31.85	15850	3.33	9104	32.	4763459	32.	4764019
47	37.38	17984	2.84	9104	36.	4763463	36.	4764023
43	40.36	19392	2.68	9104	40.	4763467	40.	4764027
40	43.65	21553	2.74	9087	45.	4763473	45.	4764033
36	48.51	23821	2.51	9087	50.	4763479	50.	4764039
30	58.85	27956	2.01	9104	56.	4763483	56.	4764043
26	66.63	31557	1.83	9104	63.	4763487	63.	4764047
25	69.13	33601	1.86	9084	71.	4763493	71.	4764053
22	97.71	38568	1.63	9074	80.	4763499	80.	4764059
19	91.32	42780	1.43	9080	90.	4763505	90.	4764065
17	101.47	47075	1.31	9067	100	4763511	100	4764071
16	107.80	51775	1.38	9055	112	4763517	112	4764077
15	115.82	55326	1.23	9057	125	4763523	125	4764083
12	144.71	66423	0.99	9041	140	4763529	140	4764089

Motors are available from Rexnord or Rexnord Distributors.

15 HP/254TC Motor Falk Part No. 1940404 Conforms to the following specifications:

C Face motor less base, TEFC, 1750 rpm, 208–230/460 Volts, 3 Phase, 60 Hz, NEMA B, 1.15 Service Factor.

Motors meeting other specifications are available upon request.

† Refer to Page 6 for Reference Notes.

UW – Gearmotor Selection Table †

20 HP/1750rpm/256TC Frame Motor

(Also use these selections for UW drives with TA bushing. Refer to Falk for Part No.)

Approx Output rpm	Exact Ratio	Actual Output Torque (lb-in)	Service Factor	Overhung Load (lb)	Hollow L.S. Shaft Basic Drive Gearmotor Less Motor Inch Dimensioned		Hollow L.S. Shaft With Drywell Flange Mounted Gearmotor Less Motor Inch Dimensioned	
					Drive Designation	Part No.	Drive Designation	Part No.
222	7.90	5214	1.00	4496	07UWBQ2A8.0A_E	4760660	07UWXQ2A8.0A_E	4761045
225	7.77	5142	1.80	5642	08UWBQ2A8.0A_E	4760781	08UWXQ2A8.0A_E	4761168
159	11.01	7278	1.48	5979	11.	4760785	11.	4761172
143	12.24	8115	1.39	6069	12.	4760789	12.	4761176
129	13.61	8998	1.30	6204	14.	4760793	14.	4761180
113	15.54	9901	1.15	6474	16.	4760797	16.	4761184
99	17.60	11553	1.12	6474	18.	4760801	18.	4761188
89	19.76	13040	1.04	6474	20.	4760805	20.	4761192
220	7.97	5332	3.22	7823	09UWBQ2A8.0A_E	4760911	09UWXQ2A8.0A_E	4761298
159	10.98	7331	2.69	7823	11.	4760915	11.	4761302
142	12.30	8203	2.52	7823	12.	4760919	12.	4761306
127	13.81	9198	2.36	7823	14.	4760923	14.	4761310
105	16.68	10622	2.01	7820	16.	4760927	16.	4761314
98	17.79	11821	2.03	7820	18.	4760931	18.	4761318
88	19.88	13218	1.90	7820	20.	4760935	20.	4761322
76	22.96	14612	1.66	7818	22.	4760939	22.	4761326
68	25.73	16306	1.55	7818	25.	4760943	25.	4761330
61	28.89	18313	1.45	7815	28.	4760947	28.	4761334
56	31.43	20704	1.43	7815	32.	4760951	32.	4761338
47	37.22	23412	1.24	7808	36.	4760955	36.	4761342
42	41.59	26098	1.16	7808	40.	4760959	40.	4761346
39	44.55	28997	1.15	7780	45.	4760965	45.	4761352
35	49.49	32038	1.08	7788	50.	4760971	50.	4761358
105	16.63	10745	3.59	9104	10UWBQ2A16.A_E	4763435	10UWXQ2A16.A_E	4763995
98	17.87	11958	3.55	9104	18.	4763439	18.	4763999
91	19.29	12891	3.39	9104	20.	4763443	20.	4764003
75	23.23	15012	2.94	9104	22.	4763447	22.	4764007
69	25.27	16343	2.79	9104	25.	4763451	25.	4764011
61	28.70	18545	2.58	9101	28.	4763455	28.	4764015
55	31.85	21134	2.50	9101	32.	4763459	32.	4764019
47	37.38	23979	2.13	9101	36.	4763463	36.	4764023
43	40.36	25856	2.01	9098	40.	4763467	40.	4764027
40	43.65	28737	2.06	9080	45.	4763473	45.	4764033
36	48.51	31761	1.88	9080	50.	4763479	50.	4764039
30	58.85	37275	1.51	9091	56.	4763483	56.	4764043
26	66.63	42077	1.37	9089	63.	4763487	63.	4764047
25	69.18	44801	1.40	9076	71.	4763493	71.	4764053
22	79.51	51424	1.23	9062	80.	4763499	80.	4764059
19	91.32	57040	1.07	9070	90.	4763505	90.	4764065
17	101.47	62767	0.99	9052	100	4763511	100	4764071
16	107.80	69034	1.04	9035	112	4763517	112	4764077
15	115.82	73768	0.92	9037	125	4763523	125	4764083

Motors are available from Rexnord or Rexnord Distributors.

20 HP/256TC Motor Falk Part No. 1940405 Conforms to the following specifications:

C Face motor less base, TEFC, 1750 rpm, 208–230/460 Volts, 3 Phase, 60 Hz, NEMA B, 1.15 Service Factor.

Motors meeting other specifications are available upon request.

† Refer to Page 6 for Reference Notes.

UW – Gearmotor Selection Table †

25 HP/1750rpm/284TC Frame Motor

(Also use these selections for UW drives with TA bushing. Refer to Falk for Part No.)

Approx Output rpm	Exact Ratio	Actual Output Torque (lb-in)	Service Factor	Overhung Load (lb)	Hollow L.S. Shaft Basic Drive Gearmotor Less Motor Inch Dimensioned		Hollow L.S. Shaft With Drywell Flange Mounted Gearmotor Less Motor Inch Dimensioned	
					Drive Designation	Part No.	Drive Designation	Part No.
					09UWBQ2A8.0A_F	4760912	09UWXQ2A8.0A_F	4761299
159	10.98	9164	2.15	7823	11.	4760916	11.	4761303
142	12.30	10253	2.02	7823	12.	4760920	12.	4761307
127	13.81	11498	1.88	7823	14.	4760924	14.	4761311
105	16.68	13278	1.61	7816	16.	4760928	16.	4761315
98	17.79	14776	1.62	7816	18.	4760932	18.	4761319
88	19.88	16522	1.52	7816	20.	4760936	20.	4761323
76	22.96	18266	1.33	7814	22.	4760940	22.	4761327
68	25.73	20383	1.24	7814	25.	4760944	25.	4761331
61	28.89	22892	1.16	7808	28.	4760948	28.	4761335
56	31.43	25880	1.14	7808	32.	4760952	32.	4761339
158	11.11	9341	3.75	9104	10UWBQ2A11.A_F	4763424	10UWXQ2A11.A_F	4763984
145	12.08	10149	3.57	9104	12.	4763428	12.	4763988
128	13.72	11502	3.32	9104	14.	4763432	14.	4763992
105	16.63	13431	2.87	9104	16.	4763436	16.	4763996
98	17.87	14948	2.84	9104	18.	4763440	18.	4764000
91	19.29	16113	2.71	9104	20.	4763444	20.	4764004
75	23.23	18766	2.35	9104	22.	4763448	22.	4764008
69	25.27	20428	2.23	9104	25.	4763452	25.	4764012
61	28.70	23181	2.06	9098	28.	4763456	28.	4764016
55	31.85	26417	2.00	9098	32.	4763460	32.	4764020
47	37.38	29974	1.70	9098	36.	4763464	36.	4764024
43	40.36	32320	1.61	9091	40.	4763468	40.	4764028
40	43.65	35922	1.64	9073	45.	4763474	45.	4764034
36	48.51	39701	1.50	9073	50.	4763480	50.	4764040
30	58.85	46593	1.21	9077	56.	4763484	56.	4764044
26	66.63	52596	1.10	9074	63.	4763488	63.	4764048
25	69.18	56002	1.12	9068	71.	4763494	71.	4764054
22	79.71	64280	0.98	9049	80.	4763500	80.	4764060

Motors are available from Rexnord or Rexnord Distributors.

25 HP/284TC Motor Falk Part No. 1940406 Conforms to the following specifications:

C Face motor less base, TEFC, 1750 rpm, 208-230/460 Volts, 3 Phase, 60 Hz, NEMA B, 1.15 Service Factor.

Motors meeting other specifications are available upon request.

† Refer to Page 6 for Reference Notes.

30 HP/1750rpm/286TC Frame Motor

Approx Output rpm	Exact Ratio	Actual Output Torque (lb-in)	Service Factor	Overhung Load (lb)	Hollow L.S. Shaft Basic Drive Gearmotor Less Motor Inch Dimensioned		Hollow L.S. Shaft With Drywell Flange Mounted Gearmotor Less Motor Inch Dimensioned	
					Drive Designation	Part No.	Drive Designation	Part No.
					09UWBQ2A8.0A_F	4760912	09UWXQ2A8.0A_F	4761299
159	10.98	10997	1.79	7823	11.	4760916	11.	4761303
142	12.30	12304	1.68	7823	12.	4760920	12.	4761307
127	13.81	13798	1.57	7823	14.	4760924	14.	4761311
105	16.68	15934	1.34	7813	16.	4760928	16.	4761315
98	17.79	17731	1.35	7813	18.	4760932	18.	4761319
88	19.88	19827	1.26	7813	20.	4760936	20.	4761323
76	22.96	21919	1.11	7809	22.	4760940	22.	4761327
68	25.73	24460	1.03	7809	25.	4760944	25.	4761331
220	7.95	8019	3.77	9104	10UWBQ2A8.0A_F	4763420	10UWXQ2A8.0A_F	4763980
158	11.11	11209	3.12	9104	11.	4763424	11.	4763984
145	12.08	12179	2.98	9104	12.	4763428	12.	4763988
128	13.72	13803	2.77	9104	14.	4763432	14.	4763992
105	16.63	16118	2.39	9104	16.	4763436	16.	4763996
98	17.87	17938	2.36	9104	18.	4763440	18.	4764000
91	19.29	19336	2.26	9104	20.	4763444	20.	4764004
75	23.23	22519	1.96	9104	22.	4763448	22.	4764008
69	25.27	24514	1.86	9104	25.	4763452	25.	4764012
61	28.70	27818	1.72	9095	28.	4763456	28.	4764016
55	31.85	31769	1.66	9095	32.	4763460	32.	4764020
47	37.38	38784	1.42	9095	36.	4763464	36.	4764024
43	40.36	43106	1.34	9085	40.	4763468	40.	4764028
40	43.65	47642	1.37	9066	45.	4763474	45.	4764034
36	48.51	55912	1.25	9066	50.	4763480	50.	4764040
30	58.85	63115	1.01	9064	56.	4763484	56.	4764044
25	66.63		0.91	9059	63.	4763488	63.	4764048

Motors are available from Rexnord or Rexnord Distributors.

30 HP/286TC Motor Falk Part No. 1940407 Conforms to the following specifications:

C Face motor less base, TEFC, 1750 rpm, 208-230/460 Volts, 3 Phase, 60 Hz, NEMA B, 1.15 Service Factor.

Motors meeting other specifications are available upon request.

† Refer to Page 6 for Reference Notes.

UW – Gearmotor Selection Table †

40 HP/1750 rpm/324TC Frame Motor

(Also use these selections for UW drives with TA bushing. Refer to Falk for Part No.)

Approx Output rpm	Exact Ratio	Actual Output Torque (lb-in)	Service Factor	Overhung Load (lb)	Hollow L.S. Shaft Basic Drive Gearmotor Less Motor Inch Dimensioned		Hollow L.S. Shaft With Drywell Flange Mounted Gearmotor Less Motor Inch Dimensioned	
					Drive Designation	Part No.	Drive Designation	Part No.
220	7.97	10664	1.61	7823	09UWBQ2A8.0A_G	4760913	09UWXQ2A8.0A_G	4761300
159	10.98	14663	1.35	7823	11.	4760917	11.	4761304
142	12.30	16406	1.26	7823	12.	4760921	12.	4761308
127	13.81	18397	1.18	7823	14.	4760925	14.	4761312
105	16.68	21245	1.01	7807	16.	4760929	16.	4761316
98	17.79	23642	1.01	7807	18.	4760933	18.	4761320
220	7.95	10693	2.83	9104	10UWBQ2A8.0A_G	4763421	10UWXQ2A8.0A_G	4763981
158	11.11	14946	2.34	9104	11.	4763425	11.	4763985
145	12.08	16238	2.23	9104	12.	4763429	12.	4763989
128	13.72	18404	2.08	9104	14.	4763433	14.	4763993
105	16.63	21490	1.79	9104	16.	4763437	16.	4763997
98	17.87	23917	1.77	9104	18.	4763441	18.	4764001
91	19.29	25782	1.70	9104	20.	4763445	20.	4764005
75	23.23	30025	1.47	9104	22.	4763449	22.	4764009
69	25.27	32686	1.40	9104	25.	4763453	25.	4764013
61	28.70	38090	1.29	9088	28.	4763457	28.	4764017
55	31.85	42268	1.25	9088	32.	4763461	32.	4764021
47	37.38	47959	1.07	9088	36.	4763465	36.	4764025
43	40.36	51712	1.01	9072	40.	4763469	40.	4764029
40	43.65	57475	1.03	9051	45.	4763473	45.	4764033
36	48.51	63523	0.94	9051	50.	4763481	50.	4764041

Motors are available from Rexnord or Rexnord Distributors.

40 HP/324TC Motor
Falk Part No. 1940408
Conforms to the following specifications:

C Face motor less base, TEFC, 1750 rpm, 208-230/460 Volts, 3 Phase, 60 Hz, NEMA B, 1.15 Service Factor.

Motors meeting other specifications are available upon request.

† Refer to Page 6 for Reference Notes.

50 HP/1750 rpm/326TC Frame Motor

Approx Output rpm	Exact Ratio	Actual Output Torque (lb-in)	Service Factor	Overhung Load (lb)	Hollow L.S. Shaft Basic Drive Gearmotor Less Motor Inch Dimensioned		Hollow L.S. Shaft With Drywell Flange Mounted Gearmotor Less Motor Inch Dimensioned	
					Drive Designation	Part No.	Drive Designation	Part No.
220	7.97	13330	1.29	7823	09UWBQ2A8.0A_G	4760913	09UWXQ2A8.0A_G	4761300
159	10.98	18329	1.08	7823	11.	4760917	11.	4761304
142	12.30	20507	1.01	7823	12.	4760921	12.	4761308
220	7.95	13366	2.26	9104	10UWBQ2A8.0A_G	4763421	10UWXQ2A8.0A_G	4763981
158	11.11	18682	1.87	9104	11.	4763425	11.	4763985
145	12.08	20298	1.79	9104	12.	4763429	12.	4763989
128	13.72	23005	1.66	9104	14.	4763433	14.	4763993
105	16.63	26863	1.43	9104	16.	4763437	16.	4763997
98	17.87	39897	1.42	9104	18.	4763441	18.	4764001
91	19.29	32227	1.36	9104	20.	4763445	20.	4764005
75	23.23	37532	1.17	9104	22.	4763449	22.	4764009
69	25.27	40857	1.12	9104	25.	4763453	25.	4764013
61	28.70	46363	1.03	9082	28.	4763457	28.	4764017
55	31.85	52835	1.00	9082	32.	4763461	32.	4764021
47	38.37	59949	0.85	9082	36.	4763465	36.	4764025

Motors are available from Rexnord or Rexnord Distributors.

50 HP/326TC Motor
Falk Part No. 1940409
Conforms to the following specifications:

C Face motor less base, TEFC, 1750 rpm, 208-230/460 Volts, 3 Phase, 60 Hz, NEMA B, 1.15 Service Factor.

Motors meeting other specifications are available upon request.

† Refer to Page 6 for Reference Notes.

Type UW Double Reduction Gearmotor

Sizes 03-06 — Dimensions – Inches

For TA Taper Bushing Dimensions, PA & PB, See Page 51.

BASIC DRIVE HOLLOW LOW SPEED SHAFT

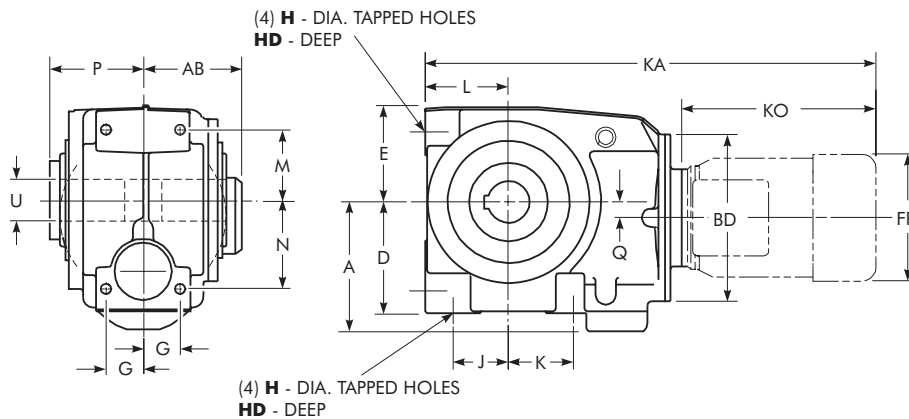

SIZE ★	A	D	E	G	H	HD	J	K	L	M	N	P	Q	Hollow L.S. Shaft	
														U + .0005 - .0000	Keyway
03	3.13	2.80	2.68	1.06	M8 x 1.25	0.59	1.38	1.10	2.13	1.57	1.57	2.76	0.21	0.7500	.19 x .09 x 4.88
04	3.66	3.39	2.95	1.10	M10 x 1.50	0.79	1.38	1.77	2.52	2.09	2.56	2.93	0.59	1.2500	.25 x .12 x 5.12
05	4.41	3.78	3.46	1.34	M10 x 1.50	0.71	1.77	2.17	2.68	2.56	3.03	3.11	0.51	1.3750	.31 x .16 x 5.52
06	5.49	4.72	4.06	1.57	M12 x 1.75	0.79	2.20	2.60	3.54	2.99	3.78	3.98	0.67	1.5000	.38 x .17 x 7.08

Typical NEMA Motor Dimensions ★

Frame Size	DRIVE SIZE							
	All Sizes				03	04	05	06
	AB	BD	FP	KO (Max)	KA (Max)	KA (Max)	KA (Max)	KA (Max)
56C	5.25	6.50	7.19	12.00	20.73	21.02	21.77	23.38
143TC/145TC	5.25	6.50	7.19	12.06	20.29	21.08	21.83	23.44
182TC/184TC	5.88	9.00	8.50	15.44	24.30	25.08	25.83	28.69
213TC/215TC	7.38	9.00	10.19	16.31	29.56

★ Refer to Page 6 for General Information and Reference Notes.

Type UW Triple Reduction Gearmotor

Sizes 03-06 — Dimensions — Inches

For TA Taper Bushing Dimensions, PA & PB, See Page 51.

BASIC DRIVE HOLLOW LOW SPEED SHAFT

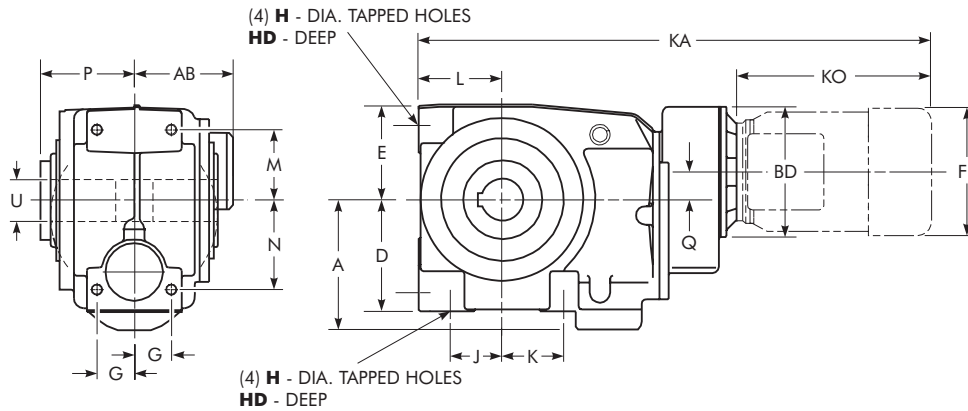

SIZE ★	A	D	E	G	H	HD	J	K	L	M	N	P	Q	Hollow L.S. Shaft	
														U + .0005 - .0000	Keyway
03	3.13	2.80	2.68	1.06	M8 x 1.25	0.59	1.38	1.10	2.13	1.57	1.57	2.76	1.21	0.7500	.19 x .09 x 4.88
04	3.66	3.39	2.95	1.10	M10 x 1.50	0.79	1.38	1.77	2.52	2.09	2.56	2.93	0.83	1.2500	.25 x .12 x 5.12
05	4.41	3.78	3.46	1.34	M10 x 1.50	0.71	1.77	2.17	2.68	2.56	3.03	3.11	0.91	1.3750	.31 x .16 x 5.52
06	5.49	4.72	4.06	1.57	M12 x 1.75	0.79	2.20	2.60	3.54	2.99	3.78	3.98	1.18	1.5000	.38 x .17 x 7.08

Typical NEMA Motor Dimensions ★

Frame Size	DRIVE SIZE							
	All Sizes				03	04	05	06
	AB	BD	FP	KO (Max)	KA (Max)	KA (Max)	KA (Max)	KA (Max)
56C	5.25	6.50	7.19	12.00	22.43	23.22	23.97	26.61
143TC/145TC	5.25	6.50	7.19	12.06	22.49	23.28	24.03	26.67
182TC/184TC	5.88	9.00	8.50	15.44	30.68

★ Refer to Page 6 for General Information and Reference Notes.

Type UW Quadruple Reduction Gearmotor

Size 06 — Dimensions – Inches

For TA Taper Bushing Dimensions, PA & PB, See Page 51.

BASIC DRIVE HOLLOW LOW SPEED SHAFT

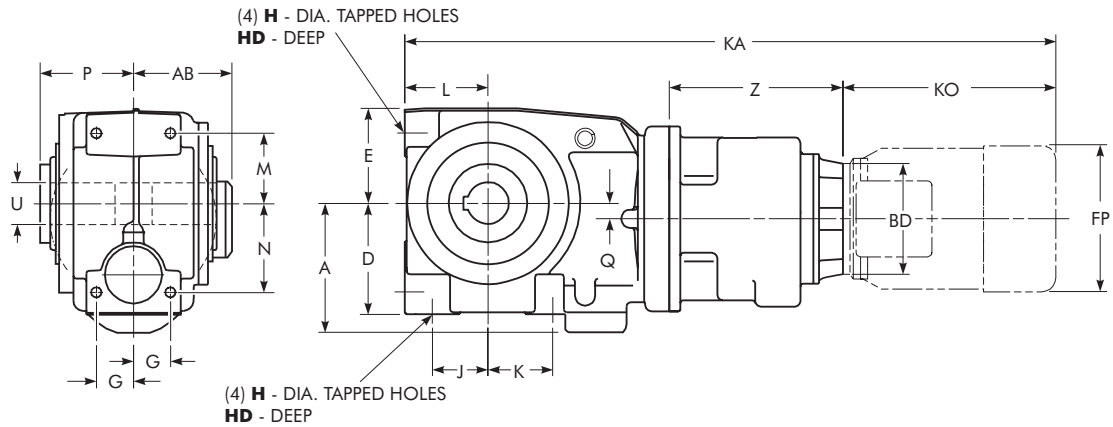

SIZE ★	A	D	E	G	H	HD	J	K	L	M	N	P	Q	Hollow L.S. Shaft	
														U + .0005 - .0000	Keyway
06	5.49	4.72	4.06	1.57	M12 x 1.75	0.79	2.20	2.60	3.54	2.99	3.78	3.98	0.67	1.5000	.38 x .17 x 7.08

Typical NEMA Motor Dimensions ★

Frame Size	AB	BD	FP	KO (Max)	KA (Max)	Z
56C	5.25	6.50	7.19	12.00	31.21	7.93
143TC/145TC	5.25	6.50	7.19	12.06	31.27	7.93

★ Refer to Page 6 for General Information and Reference Notes.

Type UW Quintuple Reduction Gearmotor

Size 06 — Dimensions — Inches

For TA Taper Bushing Dimensions, PA & PB, See Page 51.

BASIC DRIVE HOLLOW LOW SPEED SHAFT

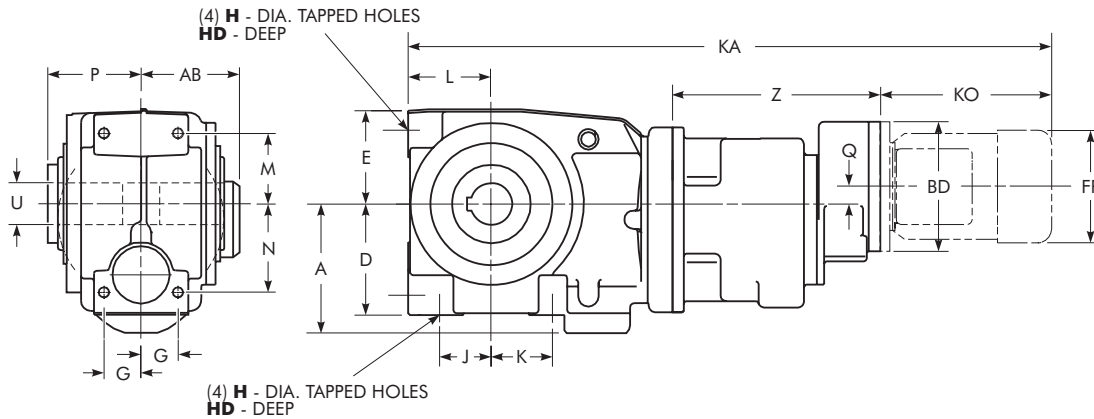

SIZE ★	A	D	E	G	H	HD	J	K	L	M	N	P	Q	Hollow L.S. Shaft	
														U +.0005 -.0000	Keyway
06	5.49	4.72	4.06	1.57	M12 x 1.75	0.79	2.20	2.60	3.54	2.99	3.78	3.98	0.75	1.5000	.38 x .17 x 7.08

Typical NEMA Motor Dimensions ★

Frame Size	AB	BD	FP	KO (Max)	KA (Max)	Z
56C	5.25	6.50	7.19	12.00	33.42	10.16
143TC/145TC	5.25	6.50	7.19	12.06	33.46	10.16

★ Refer to Page 6 for General Information and Reference Notes.

Type UW Double Reduction Gearmotor

Sizes 07-10 — Dimensions – Inches

For TA Taper Bushing Dimensions, PA & PB, See Page 51.

BASIC DRIVE HOLLOW LOW SPEED SHAFT INTEGRAL BASE MOUNTED FEET

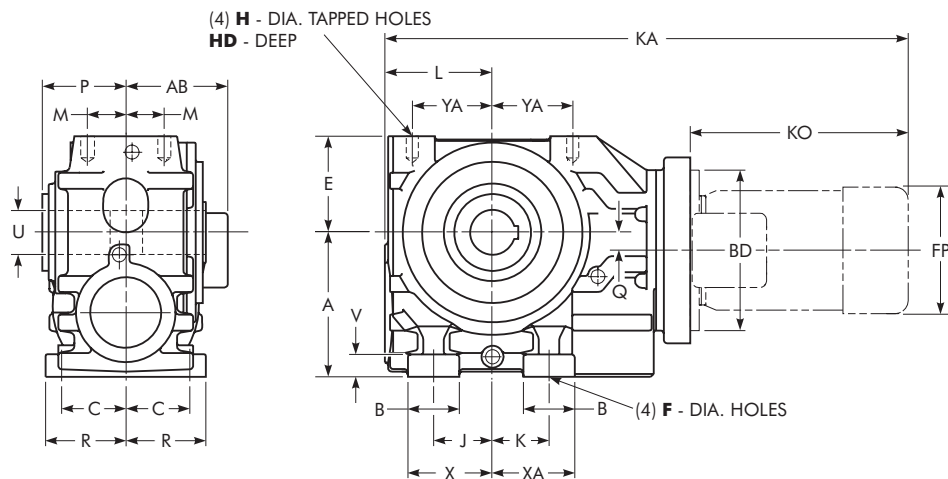

SIZE ★	A	B	C	E	F	H	HD	J	K	L	M	P	Q	R	Hollow L.S. Shaft		V	X	XA	YA
															U +.001 -.000	Keyway				
07	7.1	2.64	2.95	4.80	0.71	M20 x 2.50	1.34	2.95	2.36	5.63	1.97	4.90	1.02	3.64	2.000	.50 x .23 x 8.58	1.10	4.27	3.68	4.23
08	8.9	3.15	3.94	5.91	0.87	M20 x 2.50	1.34	3.62	3.46	6.61	2.36	5.63	1.10	4.92	2.375	.63 x .29 x 9.84	1.38	5.20	5.04	4.92
09	11.0	3.35	4.92	6.97	1.02	M24 x 3.00	1.77	4.53	4.72	7.68	2.66	6.65	1.57	6.00	2.750	.63 x .29 x 11.82	1.57	6.20	6.40	5.71
10	13.2	4.33	5.91	9.06	1.02	M24 x 3.00	1.77	6.69	5.51	9.25	2.95	7.80	2.56	7.09	3.250	.75 x .34 x 13.78	1.77	8.86	7.68	6.79

Typical NEMA Motor Dimensions ★

Frame Size	DRIVE SIZE							
	All Sizes				07	08	09	10
	AB	BD	FP	KO (Max)	KA (Max)	KA (Max)	KA (Max)	KA (Max)
56C	5.25	6.50	7.19	12.00	27.78	30.78
143TC/145TC	5.25	6.50	7.19	12.06	27.84	30.84
182TC/184TC	5.88	9.00	8.50	15.44	32.02	34.22	37.45	41.04
213TC/215TC	7.38	9.00	10.19	16.31	32.90	35.09	38.32	41.91
254TC/256TC	8.94	9.13	12.50	19.63	39.54	41.73	46.33	49.73
284TC/286TC	13.13	11.19	15.56	23.19	50.76	56.97
324TC/326TC	14.13	13.38	16.94	25.25	58.32	61.72

★ Refer to Page 6 for General Information and Reference Notes.

Type UW Triple Reduction Gearmotor

Size 07 — Dimensions – Inches

For TA Taper Bushing Dimensions, PA & PB, See Page 51.

BASIC DRIVE HOLLOW LOW SPEED SHAFT INTEGRAL BASE MOUNTED FEET

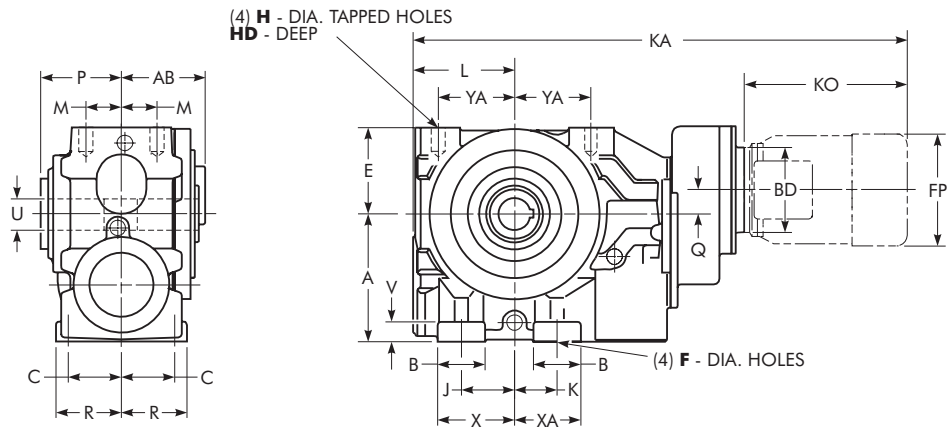

SIZE ★	A	B	C	E	F	H	HD	J	K	L	M	P	Q	R	Hollow L.S. Shaft		V	X	XA	YA
															U +.001 -.000	Keyway				
07	7.10	2.64	2.95	4.80	0.71	M20 x 2.50	1.34	2.95	2.36	5.63	1.97	4.90	1.34	3.64	2.000	.50 x .23 x 8.58	1.10	4.27	3.68	4.23

Typical NEMA Motor Dimensions ★

Frame Size	AB	BD	FP	KO (Max)	KA (Max)
56C	5.25	6.50	7.19	12.00	31.02
143TC/145TC	5.25	6.50	7.19	12.06	31.08
182TC/184TC	5.88	9.00	8.50	15.44	35.97
213TC/215TC	7.38	9.00	10.19	16.31	36.84

★ Refer to Page 6 for General Information and Reference Notes.

Type UW Quadruple Reduction Gearmotor

Sizes 07-10 — Dimensions – Inches
 For TA Taper Bushing Dimensions, PA & PB, See Page 51.

BASIC DRIVE HOLLOW LOW SPEED SHAFT INTEGRAL BASE MOUNTED FEET

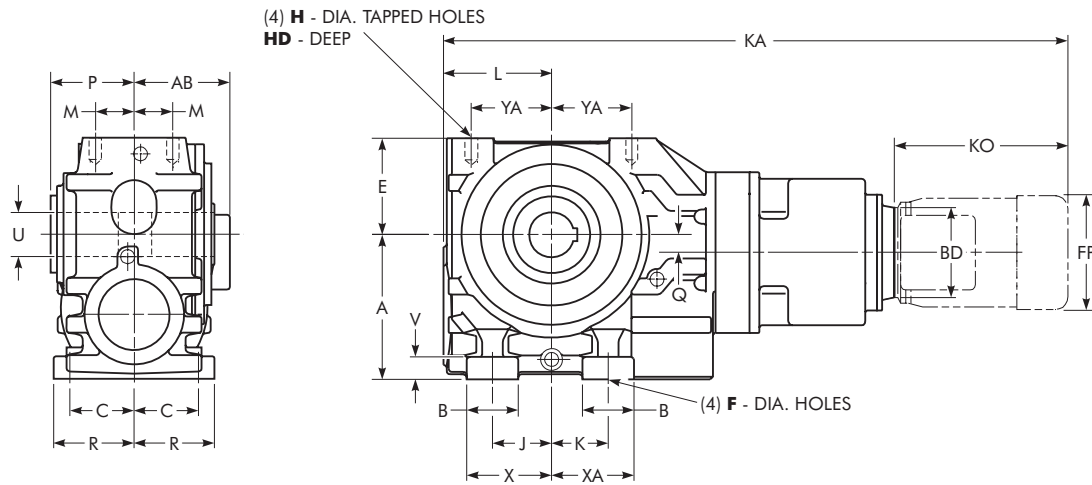

SIZE ★	A	B	C	E	F	H	HD	J	K	L	M	P	Q	R	Hollow L.S. Shaft		V	X	XA	YA
															U +.001 -.000	Keyway				
07	7.1	2.64	2.95	4.80	0.71	M20 x 2.50	1.34	2.95	2.36	5.63	1.97	4.90	1.02	3.64	2.000	.50 x .23 x 8.58	1.10	4.27	3.68	4.23
08	8.9	3.15	3.94	5.91	0.87	M20 x 2.50	1.34	3.62	3.46	6.61	2.36	5.63	1.10	4.92	2.375	.63 x .29 x 9.84	1.38	5.20	5.04	4.92
09	11.0	3.35	4.92	6.97	1.02	M24 x 3.00	1.77	4.53	4.72	7.68	2.66	6.65	1.57	6.00	2.750	.63 x .29 x 11.82	1.57	6.20	6.40	5.71
10	13.2	4.33	5.91	9.06	1.02	M24 x 3.00	1.77	6.69	5.51	9.25	2.95	7.80	2.56	7.09	3.250	.75 x .34 x 13.78	1.77	8.86	7.68	6.79

Typical NEMA Motor Dimensions ★

Frame Size	DRIVE SIZE							
	All Sizes				07	08	09	10
	AB	BD	FP	KO (Max)	KA (Max)	KA (Max)	KA (Max)	KA (Max)
56C	5.25	6.50	7.19	12.00	34.87	39.88	43.15	48.22
143TC/145TC	5.25	6.50	7.19	12.06	34.93	39.94	43.21	48.28
182TC/184TC	5.88	9.00	8.50	15.44	38.74	44.83	48.10	52.46
213TC/215TC	7.38	9.00	10.19	16.31	...	45.70	48.97	53.34

★ Refer to Page 6 for General Information and Reference Notes.

Type UW Quintuple Reduction Gearmotor

Sizes 07-10 — Dimensions — Inches

For TA Taper Bushing Dimensions, PA & PB, See Page 51.

BASIC DRIVE HOLLOW LOW SPEED SHAFT INTEGRAL BASE MOUNTED FEET

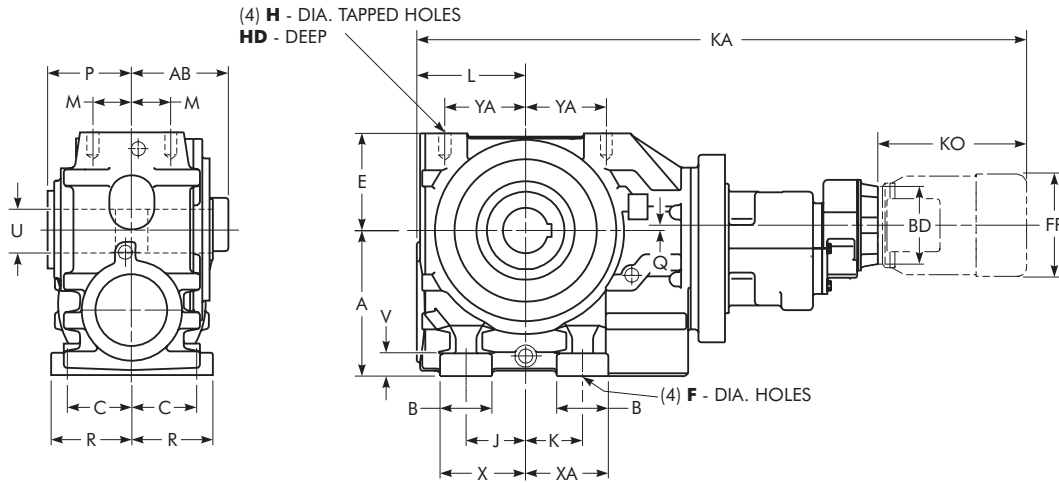

SIZE ★	A	B	C	E	F	H	HD	J	K	L	M	P	Q	R	Hollow L.S. Shaft		V	X	XA	YA
															U + .001 - .000	Keyway				
07	7.1	2.64	2.95	4.80	0.71	M20 x 2.50	1.34	2.95	2.36	5.63	1.97	4.90	0.39	3.64	2.000	.50 x .23 x 8.58	1.10	4.27	3.68	4.23
08	8.9	3.15	3.94	5.91	0.87	M20 x 2.50	1.34	3.62	3.46	6.61	2.36	5.63	0.32	4.92	2.375	.63 x .29 x 9.84	1.38	5.20	5.04	4.92
09	11.0	3.35	4.92	6.97	1.02	M24 x 3.00	1.77	4.53	4.72	7.68	2.66	6.65	0.28	6.00	2.750	.63 x .29 x 11.82	1.57	6.20	6.40	5.71
10	13.2	4.33	5.91	9.06	1.02	M24 x 3.00	1.77	6.69	5.51	9.25	2.95	7.80	0.71 †	7.09	3.250	.75 x .34 x 13.78	1.77	8.86	7.68	6.79

† Dimension is below the centerline.

Typical NEMA Motor Dimensions ★

Frame Size	DRIVE SIZE							
	All Sizes				07	08	09	10
	AB	BD	FP	KO (Max)	KA (Max)	KA (Max)	KA (Max)	KA (Max)
56C	5.25	6.50	7.19	12.00	37.79	40.90	46.22	49.29
143TC/145TC	5.25	6.50	7.19	12.06	37.85	40.96	46.28	49.35
182TC/184TC	5.88	9.00	8.50	15.44	50.09	53.16

★ Refer to Page 6 for General Information and Reference Notes.

Type UW Double Reduction Gearmotor Drive

For Triple, Quad & Quint Reduction, See Individual Dimension Pages

Sizes 05-10 — Dimensions — Inches

BASIC DRIVE WITH TA TAPER BUSHING

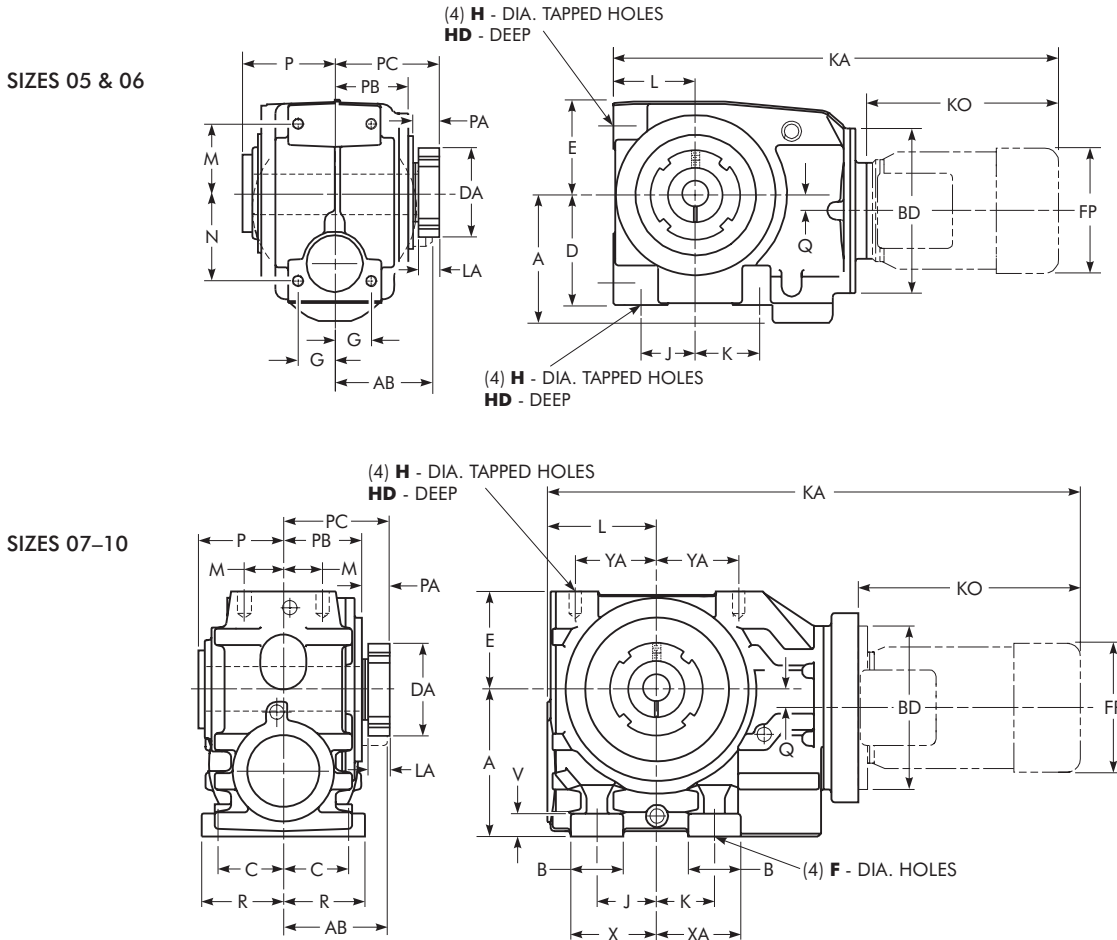

SIZE ★	A	B	C	D	DA	E	F	G	H	HD	J	K	L	LA	M	N	P	PA	PB	PC	Q	R	V	X	XA	YA
05	4.4	3.78	3.31	3.46	...	1.34	M10 x 1.50	0.71	1.77	2.17	2.68	1.26	2.56	3.03	3.11	2.17	2.44	4.62	0.51
06	5.5	4.72	4.06	4.06	...	1.57	M12 x 1.75	0.79	2.20	2.60	3.54	1.46	2.99	3.78	3.98	2.37	3.17	5.54	0.67
07	7.1	2.64	2.95	...	4.31	4.80	0.71	...	M20 x 2.50	1.34	2.95	2.36	5.63	1.46	1.97	...	4.90	1.97	4.09	6.08	1.02	3.64	1.10	4.27	3.68	4.23
08	8.9	3.15	3.94	...	4.81	5.91	0.87	...	M20 x 2.50	1.34	3.62	3.46	6.61	1.46	2.36	...	5.63	2.03	4.72	6.75	1.10	4.92	1.38	5.20	5.04	4.92
09	11.0	3.35	4.92	...	5.68	6.97	1.02	...	M24 x 3.00	1.77	4.53	4.72	7.68	1.76	2.66	...	6.65	2.24	5.67	7.91	1.57	6.00	1.57	6.20	6.40	5.71
10	13.2	4.33	5.91	...	6.06	9.06	1.02	...	M24 x 3.00	1.77	6.69	5.51	9.25	1.76	2.95	...	7.80	2.41	6.55	18.96	2.56	7.09	1.77	8.86	7.68	6.79

Typical NEMA Motor Dimensions ★

Frame Size	DRIVE SIZE									
	All Sizes				05	06	07	08	09	10
	AB	BD	FP	KO (Max)	KA (Max)	KA (Max)	KA (Max)	KA (Max)	KA (Max)	KA (Max)
56C	5.25	6.50	7.19	12.00	21.77	23.38	27.78	30.78
143TC/145TC	5.25	6.50	7.19	12.06	21.83	23.44	27.84	30.84
182TC/184TC	5.88	9.00	8.50	15.44	25.83	28.69	34.22	37.45	41.04	41.04
213TC/215TC	7.38	9.00	10.19	16.31	...	29.56	32.90	35.09	38.32	41.91
254TC/256TC	8.94	9.13	12.50	19.63	39.54	41.73	46.33	49.73
284TC/286TC	13.13	11.19	15.56	23.19	50.76	56.97
324TC/326TC	14.13	13.38	16.94	25.25	58.32	61.72

★ Refer to Page 6 for General Information and Reference Notes.

Type UW Helical-Worm Gearmotor & Gear Drive

Sizes 05-10 — Dimensions — Inches

TA TAPER BUSHING

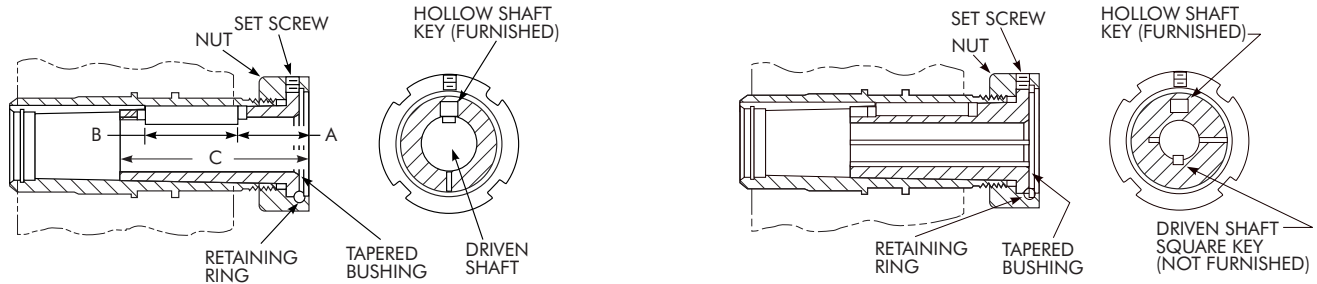

DRIVE SIZE	A	B	C Minimum Shaft Engagement	Bushing Size	Part Number †	Style No.	Driven Shaft Keyway Min Key Length •	Wt Lb
05UW	1.89	2.50	5.00	BU4107J/05UW-1.000	0769061	2	1/4 x 1/8 x 2 1/2	2.1
				BU4107J/05UW-1.125	0769062	2	1/4 x 1/8 x 2 1/4	1.8
				BU4107J/05UW-1.188	0769063	2	1/4 x 1/8 x 2	1.6
				BU4107J/05UW-1.250	0769064	1	1/4 x 1/8 x 2 1/2	1.5
				BU4107J/05UW-1.375	6720659	1	3/8 x 3/16 x 2 1/2	1.0
				BU4107J/05UW-1.438	0769065	1	3/8 x 3/16 x 2 1/2	1.0
06UW	2.10	2.75	5.55	BU4115J/06UW-1.188	0769077	2	1/4 x 1/8 x 4 1/4	4.3
				BU4115J/06UW-1.250	0769078	2	1/4 x 1/8 x 4	4.1
				BU4115J/06UW-1.438	0769079	2	3/8 x 3/16 x 2 1/4	3.5
				BU4115J/06UW-1.500	0769080	2	3/8 x 3/16 x 2 1/4	3.3
				BU4115J/06UW-1.625	0769081	1	3/8 x 3/16 x 2 3/4	2.9
				BU4115J/06UW-1.688	0769082	1	3/8 x 3/16 x 2 3/4	2.7
				BU4115J/06UW-1.750	0769083	1	3/8 x 3/16 x 2 3/4	2.4
				BU4115J/06UW-1.938	0769084	1	1/2 x 1/4 x 2 3/4	1.7
07UW	1.56	3.25	5.53	BU4203J/07UW-1.438	0769117	2	3/8 x 3/16 x 3 1/4	5.0
				BU4203J/07UW-1.500	0769118	2	3/8 x 3/16 x 3 1/4	5.1
				BU4203J/07UW-1.625	0769119	2	3/8 x 3/16 x 3	4.6
				BU4203J/07UW-1.688	0769120	2	3/8 x 3/16 x 2 3/4	4.4
				BU4203J/07UW-1.750	0769121	2	3/8 x 3/16 x 2 3/4	4.4
				BU4203J/07UW-1.875	0769122	1	1/2 x 1/4 x 3 1/4	3.6
				BU4203J/07UW-1.938	0769123	1	1/2 x 1/4 x 3 1/4	3.3
				BU4203J/07UW-2.000	0769124	1	1/2 x 1/4 x 3 1/4	3.0
				BU4203J/07UW-2.188	0769125	1	1/2 x 1/4 x 3 1/4	3.0
				08UW	1.24	4.25	6.11	BU4207J/08UW-1.375
BU4207J/08UW-1.438	0769096	2	3/8 x 3/16 x 5 3/4					7.3
BU4207J/08UW-1.500	0769097	2	3/8 x 3/16 x 5 3/4					7.1
BU4207J/08UW-1.625	0765848	2	3/8 x 3/16 x 5 3/4					6.7
BU4207J/08UW-1.688	0769098	2	3/8 x 3/16 x 5 1/4					6.4
BU4207J/08UW-1.750	0769099	2	3/8 x 3/16 x 5 1/4					6.1
BU4207J/08UW-1.875	0769100	2	1/2 x 1/4 x 3 1/2					5.6
BU4207J/08UW-1.938	0769101	1	1/2 x 1/4 x 4 1/4					5.3
BU4207J/08UW-2.000	0769102	1	1/2 x 1/4 x 4 1/4					5.0
BU4207J/08UW-2.188	0769103	1	1/2 x 1/4 x 4 1/4					4.4
BU4207J/08UW-2.250	0769104	1	1/2 x 1/4 x 4 1/4					3.7
BU4207J/08UW-2.375	2113886	1	5/8 x 5/16 x 4 1/4					3.0
BU4207J/08UW-2.438	0769105	1	5/8 x 5/16 x 4 1/4					2.6
09UW	2.09	3.50	7.08					BU4215J/09UW-1.938
				BU4215J/09UW-2.000	0769138	2	1/2 x 1/4 x 4 3/4	11.1
				BU4215J/09UW-2.188	0769139	2	1/2 x 1/4 x 4 1/2	9.9
				BU4215J/09UW-2.250	0769140	2	1/2 x 1/4 x 4 1/4	9.5
				BU4215J/09UW-2.438	0769141	1	5/8 x 5/16 x 3 1/2	8.3
				BU4215J/09UW-2.500	0769142	1	5/8 x 5/16 x 3 1/2	7.8
				BU4215J/09UW-2.688	0769143	1	5/8 x 5/16 x 3 1/2	6.5
				BU4215J/09UW-2.750	2116065	1	5/8 x 5/16 x 3 1/2	5.5
				BU4215J/09UW-2.938	0769144	1	3/4 x 3/8 x 3 1/2	4.5
10UW	1.59	5.00	7.39	BU4307J/10UJW-2.000	0769155	2	1/2 x 1/4 x 7	17.8
				BU4307J/10UJW-2.188	0769156	2	1/2 x 1/4 x 7	16.6
				BU4307J/10UJW-2.250	0769157	2	1/2 x 1/4 x 7	16.2
				BU4307J/10UJW-2.438	0769158	2	5/8 x 5/16 x 5 1/2	14.9
				BU4307J/10UJW-2.500	0769159	2	5/8 x 5/16 x 5	14.4
				BU4307J/10UJW-2.688	0769160	1	5/8 x 5/16 x 5	13.0
				BU4307J/10UJW-2.938	0769161	1	3/4 x 3/8 x 5	10.9
				BU4307J/10UJW-3.000	0769162	1	3/4 x 3/8 x 5	10.3
				BU4307J/10UJW-3.188	0769163	1	3/4 x 3/8 x 5	8.6
				BU4307J/10UJW-3.438	0769164	1	7/8 x 7/16 x 5	6.1

† Consists of bushing, drive key, nut, retaining ring and setscrew.
 • Check strength of driven shaft and unfurnished key.

Type UW Double Reduction Gearmotor

Sizes 07-10 — Dimensions — Inches

BASIC DRIVE HOLLOW LOW SPEED SHAFT WITH DRYWELL FLANGE MOUNTED

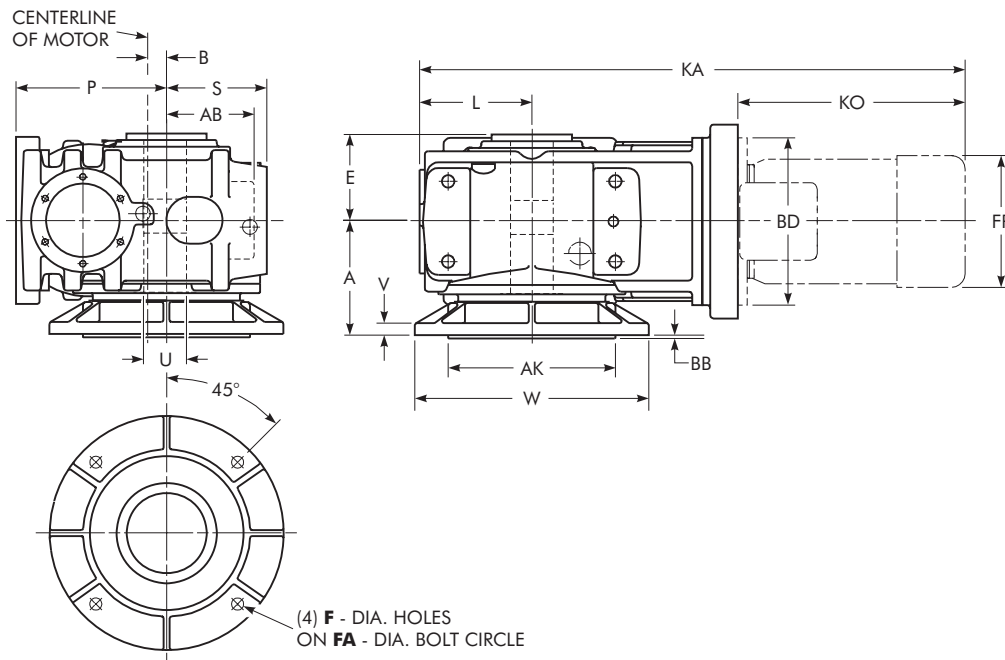

SIZE ★	A	AK	B	BB	E	F	FA	L	P	S	Hollow L.S. Shaft		V	W
											U +.001 -.000	Keyway		
07	5.43	7.09	1.02	0.16	4.90	0.55	8.46	5.63	7.1	4.80	2.000	.50 x .23 x 8.58	0.47	9.84
08	6.69	9.84	1.10	0.20	5.63	0.71	11.81	6.61	8.9	5.91	2.375	.63 x .29 x 9.84	0.71	13.78
09	7.87	13.78	1.57	0.20	6.65	0.71 ‡	15.75	7.68	11.0	6.97	2.750	.63 x .29 x 11.82	0.79	17.72
10	9.13	13.78	2.56	0.20	7.80	0.71 ‡	15.75	9.25	13.2	9.06	3.250	.75 X .34 X 13.78	0.87	17.72

‡ Size 09 & 10 have (8) F - DIA. HOLES.

Typical NEMA Motor Dimensions ★

Frame Size	DRIVE SIZE							
	All Sizes				07	08	09	10
	AB	BD	FP	KO (Max)	KA (Max)	KA (Max)	KA (Max)	KA (Max)
56C	5.25	6.50	7.19	12.00	27.78	30.78
143TC/145TC	5.25	6.50	7.19	12.06	27.84	30.84
182TC/184TC	5.88	9.00	8.50	15.44	32.02	34.22	37.45	41.04
213TC/215TC	7.38	9.00	10.19	16.31	32.90	35.09	38.32	41.91
254TC/256TC	8.94	9.13	12.50	19.63	39.54	41.73	46.33	49.73
284TC/286TC	13.13	11.19	15.56	23.19	50.76	56.97
324TC/326TC	14.13	13.38	16.94	25.25	58.32	61.72

★ Refer to Page 6 for General Information and Reference Notes.

Type UW Triple Reduction Gearmotor

Sizes 07 — Dimensions – Inches

BASIC DRIVE HOLLOW LOW SPEED SHAFT WITH DRYWELL FLANGE MOUNTED

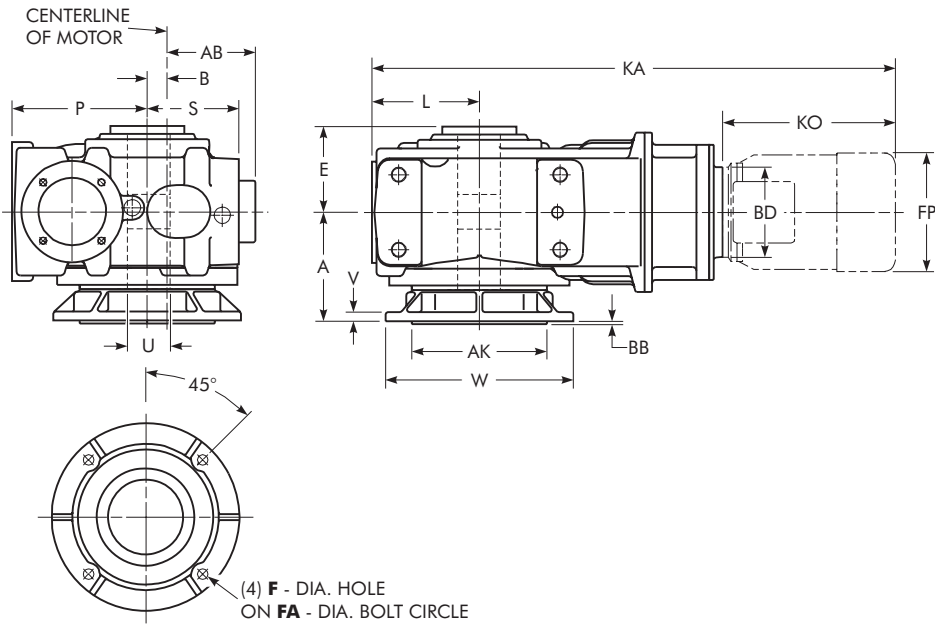

SIZE ★	A	AK	B	BB	E	F	FA	L	P	S	Hollow L.S. Shaft		V	W
											U +.001 -.000	Keyway		
07	5.43	7.09	1.02	0.16	4.90	0.55	8.46	5.63	7.1	4.80	2.000	.50 x .23 x 8.58	0.47	9.84

Typical NEMA Motor Dimensions ★

Frame Size	DRIVE SIZE				
	All Sizes				07
	AB	BD	FP	KO (Max)	KA (Max)
56C	5.25	6.50	7.19	12.00	31.02
143TC/145TC	5.25	6.50	7.19	12.06	31.08
182TC/184TC	5.88	9.00	8.50	15.44	35.97
213TC/215TC	7.38	9.00	10.19	16.31	36.84

★ Refer to Page 6 for General Information and Reference Notes.

UW – Overhung Loads

High & Low Speed Shaft

Overhung load is imposed upon a shaft when a pinion, sprocket or sheave is used as a power take-off. The magnitude of the load varies with the type of take-off and its proximity to the shaft bearing. Calculate the load and check the result against the tabulated overhung load rating.

OVERHUNG LOAD FORMULA:

$$\text{Overhung Load} = \frac{126,000 \times \text{hp} \times F_c \times L_f}{\text{Pitch Dia} \times \text{rpm}}$$

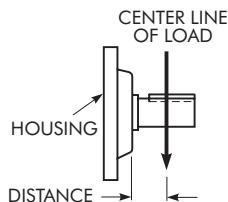

F_c = Load Connection Factor.

- Sprocket or Timing Belt . . . 1.00
- Machined Pinion & Gear . . 1.25
- V-Belt 1.50
- Flat Belt 2.50

L_f = Load Location Factor.

For overhung loads applied at the midpoint of the usable shaft extension, $L_f = 1.00$

Locate the centerline of the load as close to the drive housing as practical to minimize the overhung load and increase bearing life. The above overhung load formula employs the transmitted horsepower, without Service Factor, providing the overloads, starting loads, and brake capacities do not exceed the amounts listed in Basic Information on Page 5.

Consult Factory for Higher Overhung Load Ratings — In many cases, overhung load capacity in excess of that published is available. Published ratings are based on a combination of the most unfavorable conditions of rotation, speed, direction of applied load, and drive loading. If the actual load should exceed the published capacity, refer full details to Factory; provide complete application information, as well as direction of rotation, location and direction of applied load.

Gearmotor Overhung Load Capacity — The overhung load capacity at the low speed shaft is found in the Selection Tables on Pages 20 through 42.

Gear Drive Overhung Load Capacity — The overhung load capacity at the high speed shaft and low speed shaft are found on Page 56.

Example:

Gear Drive Size = 04UWAQ2A40.N₁, exact ratio of 39.26:1.

Motor = .50 hp at 1750 rpm.

Low speed shaft rpm = 1750 ÷ 39.26 = 44.2 rpm.

3" diameter sprocket mounted on low speed shaft. Centerline of sprocket overhung load is positioned at B = 0.91 inches. Calculate the overhung load as follows:

$$\text{OHL} = \frac{126,000 \times .50 \times 1.00 \times 1.00}{3 \times 44.2} = 473 \text{ lb}$$

Allowable OHL on Page 56 is 1770 lb and is satisfactory for this selection.

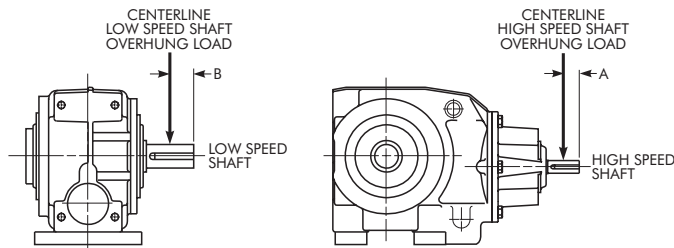

Usable Shaft Extension Midpoint

DRIVE SIZE	No. of Reductions	HSS A (in)	LSS B (in)
03	2-3	0.79	0.69
04	2-3	0.79	0.91
05	2-3	0.79	1.18
06	2-5	0.79	1.24
07	2	0.98	1.50
07	3-5	0.79	1.50
08	2	1.18	2.36
08	4-5	0.79	2.36
09	2	1.57	2.66
09	4-5	0.79	2.66
10	2	2.17	3.35
10	4	0.98	3.35
10	5	0.49	3.35

UW – Gear Drive HSS Overhung Load Ratings/Pounds

Double, Triple, Quadruple & Quintuple Reductions

Consult Factory for higher overhung load ratings

Reduction	Ratio	DRIVE SIZE †							
		03	04	05	06	07	08	09	10
Double	8.0	290	270	255	300	397	616	686	820
	14.0	300	280	260	315	412	622	713	867
	20.0	300	285	265	320	416	629	725	877
	32.0	305	290	265	320	417	631	731	884
	50.0	310	290	270	320	413	626	722	873
	71.0	310	295	265	315	410	603	727	846
	112.0	310	305	280	320	420	450	727	873
	160.0	320	305	280	335	480	697	797	1050
	250.0	320	310	290	345	480	697	797	1050
Triple	100.0	315	310	295	280	336
	180.0	315	315	300	285	345
	280.0	315	315	305	285	349
	400.0	315	315	305	290	351
	560.0	320	315	305	295	373
	900.0	320	315	305	300	374
Quadruple	All Ratios	380	380	376	376	490
Quintuple	All Ratios	380	380	380	376	376

† Published ratings are based on a combination of the most unfavorable conditions of loading. For higher ratings, refer full data to Falk.

UW – Gearmotor & Gear Drive LSS Overhung Load Ratings/Pounds

Double, Triple, Quadruple & Quintuple Reductions

Consult Factory for higher overhung load ratings

Approx L. S. Shaft rpm	DRIVE SIZE *							
	03	04	05	06	07	08	09	10
180	440	1770	1670	1730	4600	5500	7820	9110
125	440	1770	1670	1720	5030	5950	7820	9110
80	440	1770	1670	1700	5030	6470	7820	9110
50	440	1770	1670	1660	3020	6460	7820	9090
32	440	1770	1670	1640	5020	6460	7790	9080
25	440	1770	1670	1620	5000	6450	7780	9060
10	430	1770	1670	1570	5000	6450	7760	9050
5	430	1770	1670	1560	4990	6440	7760	9040
1*	430	1770	1660	1560	4990	6440	7730	9030

* The last overhung load value in each Drive Size column applies to all lower output speeds for that drive. Published ratings are based on a combination of the most unfavorable conditions of loading.

UW – Gearmotor & Gear Drive LSS Thrust Loads/Pounds

Double, Triple, Quadruple & Quintuple Reductions

Axial Thrust Capacities/Inward or Outward

Thrust capacities tabulated refer to output shafts, and are calculated without any overhung loads being applied. In cases where combined axial thrusts and overhung loads are to be applied, refer to the Factory.

Approx L. S. Shaft rpm	DRIVE SIZE *															
	03		04		05		06		07		08		09		10	
	Final Worm Ratio															
	10	20	10	20	10	20	10	20	10	20	10	20	10	20	10	20
180	980	1070	1570	1710	1480	1600	2530	2700	2790	3060	3550	3890	4080	4470	4120	4520
125	800	1070	1270	1700	1200	1590	2060	2690	2240	3050	2880	3880	3320	4470	3350	4510
80	640	1020	1020	1630	960	1520	1650	2570	1820	2920	2310	3710	2660	4270	2690	4310
50	530	940	860	1500	810	1400	1380	2380	1520	2690	1940	3430	2230	3940	2250	3980
32	490	890	780	1420	740	1330	1260	2260	1390	2560	1770	3250	2030	3740	2050	3780
25	440	840	700	1340	660	1250	1140	2120	1250	2400	1600	3050	1840	3520	1860	3550
10	400	800	640	1290	610	1200	1040	2040	1140	2310	1450	2940	1670	3380	1690	3420
5	370	790	600	1260	570	1180	980	2000	1070	2270	1370	2880	1570	3320	1590	3350
1 *	360	780	580	580	550	1170	930	1980	1030	2240	1310	2850	1510	3280	1520	3340

* The last thrust capacity value in each Drive Size column applies to all lower output speeds for that drive.

UW – Gearmotor & Gear Drive Moments of Inertia

Double Reduction

WR² (lb-in²) Referred to H.S. Shaft

Ratio	DRIVE SIZE							
	03	04	05	06	07	08	09	10
8.	0.38	0.51	1.05	3.45	9.38	28.95	77.99	157.14
11.	0.30	0.37	0.67	2.18	5.89	18.05	50.67	98.43
12.	0.27	0.33	0.59	1.88	5.08	15.80	44.13	88.11
14.	0.25	0.30	0.51	1.64	4.59	13.88	38.57	74.86
16.	0.39	0.51	1.00	3.69	7.95	24.47	69.81	124.00
18.	0.22	0.25	0.39	1.26	3.34	10.33	29.82	54.41
20.	0.22	0.24	0.35	1.11	2.92	9.11	26.10	48.75
22.	0.30	0.37	0.65	2.30	5.15	15.82	46.35	81.44
25.	0.27	0.33	0.58	1.98	4.49	14.00	40.69	73.75
28.	0.26	0.30	0.49	1.72	4.10	12.42	35.84	63.73
32.	0.19	0.20	0.26	0.75	1.94	5.70	17.28	28.64
36.	0.22	0.25	0.38	1.31	3.05	9.45	28.18	47.85
40.	0.22	0.24	0.35	1.15	2.70	8.42	24.78	43.12
45.	0.18	0.18	0.22	0.61	1.47	4.37	13.25	21.98
50.	0.17	0.18	0.21	0.59	1.34	3.97	12.16	19.79
56.	0.19	0.21	0.28	0.86	2.12	6.09	18.68	30.31
63.	0.19	0.20	0.26	0.76	1.85	5.43	16.75	26.58
71.	0.17	0.17	0.19	0.50	1.13	3.12	10.00	15.33
80.	0.17	0.17	0.18	0.49	1.09	2.99	9.50	14.06
90.	0.18	0.18	0.22	0.61	1.42	4.23	12.99	20.88
100	0.17	0.18	0.21	0.59	1.30	3.86	11.94	18.90
112	0.17	0.17	0.18	0.46	0.98	2.61	8.40	12.64
125	0.17	0.17	0.17	0.45	0.95	2.56	8.21	12.06
140	0.17	0.17	0.19	0.50	1.11	3.06	9.90	14.89
160	0.17	0.17	0.18	0.49	1.07	2.94	9.41	13.73
212	0.17	0.17	0.18	0.46	0.98	2.59	8.36	12.46
250	0.17	0.17	0.17	0.45	0.94	2.54	8.18	11.90

Values shown in the table above are referred to the drive high speed shaft. The WR² referred to the low speed shaft equals the exact total ratio squared times the H.S. shaft WR².

Triple Reduction

WR² (lb-in²) Referred to H.S. Shaft

Ratio	DRIVE SIZE				
	03	04	05	06	07
100	0.19	0.19	0.20	0.29	0.88
118	0.19	0.19	0.19	0.27	0.78
132	0.22	0.22	0.24	0.42	1.34
150	0.21	0.21	0.23	0.38	1.17
160	0.18	0.18	0.18	0.22	0.62
180	0.17	0.17	0.18	0.21	0.60
200	0.19	0.19	0.20	0.30	0.87
225	0.19	0.19	0.19	0.27	0.77
265	0.17	0.17	0.17	0.19	0.51
280	0.17	0.17	0.17	0.18	0.49
315	0.18	0.18	0.18	0.22	0.62
360	0.17	0.17	0.18	0.21	0.60
400	0.17	0.17	0.17	0.18	0.46
450	0.16	0.16	0.17	0.17	0.45
500	0.17	0.17	0.17	0.19	0.51
560	0.17	0.17	0.17	0.18	0.49
800	0.17	0.17	0.17	0.18	0.46
900	0.16	0.16	0.17	0.17	0.45

UW – Gearmotor & Gear Drive Moments of Inertia

Quadruple Reduction

WR2 (lb-in²) Referred to H.S. Shaft

Ratio	DRIVE SIZE				
	06	07	08	09	10
280	1.38	2.43	...
315	1.20	3.03	...
360	0.98	2.56	...
400	0.85	2.48	...
450	0.89	2.13	...
500	0.92	1.59	2.48
560	0.81	1.37	2.12
630	0.22	...	0.85	1.38	2.43
710	0.21	...	0.91	1.20	2.09
800	0.22	0.23	0.80	0.98	2.22
900	0.22	0.22	0.85	0.85	2.08
10C	0.21	0.22	0.76	0.89	2.21
11C	0.21	0.21	0.63	0.79	1.92
12C	0.19	0.19	0.61	0.84	1.54
14C	0.18	0.19	0.61	0.63	1.40
16C	0.18	0.19	0.59	0.62	1.47
18C	0.18	0.18	0.51	0.63	1.34
20C	0.18	0.19	0.50	0.52	1.17
22C	0.18	0.19	0.50	0.62	1.12
25C	0.17	0.18	0.49	0.51	1.14
28C	0.17	0.19	0.50	0.50	1.09
32C	0.17	0.18	0.46	0.51	1.12
36C	0.18	0.17	0.05	0.49	1.08
40C	0.17	0.18	0.45	0.50	0.99
45C	0.17	0.18	0.44	0.49	0.96
50C	0.17	0.17	0.48	0.46	0.98
56C	0.17	0.19	0.46	0.45	0.95
60C	0.17	0.18	0.45	0.46	0.96
65C	0.17	0.18	0.45	0.45	0.98
75C	0.17	0.17	0.44	0.45	0.95
85C	0.17	0.18	0.45	0.46	1.09
95C	0.17	0.17	0.44	0.45	1.12
10K	0.17	0.17	0.48	0.50	1.08
11K	0.17	0.18	0.46	0.49	0.99
12K	0.17	0.17	0.45	0.46	0.96
14K	0.17	0.18	0.45	0.45	0.98
16K	0.17	0.17	0.44	0.44	0.95

Quintuple Reduction

WR2 (lb-in²) Referred to H.S. Shaft

Ratio	DRIVE SIZE				
	06	07	08	09	10
18K	0.17	0.17	0.17	0.18	0.18
20K	0.17	0.17	0.17	0.17	0.19
22K	0.17	0.17	0.17	0.18	0.18
25K	0.17	0.17	0.17	0.17	0.18
28K	0.17	0.17	0.17	0.17	0.17
32K	0.17	0.17	0.17	0.18	0.18
36K	0.17	0.17	0.17	0.17	0.17
40K	0.17	0.17	0.17	0.18	0.18
43K	0.17	0.17	0.17	0.18	0.18
48K	0.17	0.17	0.17	0.17	0.17
53K	0.17	0.17	0.17	0.18	0.18
60K	0.17	0.17	0.17	0.17	0.17

UW – Gear Drive Horsepower & Torque Ratings

3500 High Speed Shaft rpm/Double Reduction

Ratio Code *	Approx Output rpm	SIZE 03					SIZE 04					SIZE 05					SIZE 06				
		Horsepower			Mech Output Torque (lb-in)	Eff %	Horsepower			Mech Output Torque (lb-in)	Eff %	Horsepower			Mech Output Torque (lb-in)	Eff %	Horsepower			Mech Output Torque (lb-in)	Eff %
		Mech Input	Therm Input ‡	Mech Output			Mech Input	Therm Input ‡	Mech Output			Mech Input	Therm Input ‡	Mech Output			Mech Input	Therm Input ‡	Mech Output		
8.0	407	4.24	4.69	3.54	547	83	6.74	5.17	5.77	893	84	9.54	2.79	8.29	1240	76	16.80	3.05	14.80	2200	65
11.	301	3.54	4.24	2.96	619	84	5.73	5.60	4.93	1030	85	7.95	4.33	6.96	1460	85	13.90	5.43	12.40	2590	84
12.	265	3.26	3.95	2.73	649	84	5.32	5.65	4.59	1090	86	7.55	4.40	6.57	1520	85	13.10	5.19	11.70	2730	84
14.	234	3.01	3.61	2.51	676	83	4.95	5.66	4.24	1140	86	7.05	5.11	6.13	1610	86	12.30	4.53	11.00	2880	84
16.	214	2.66	2.10	1.94	570	70	4.15	4.30	3.16	932	76	8.70	1.47	7.01	2030	56	13.60	2.03	11.00	3160	44
18.	183	2.52	2.77	2.09	720	83	4.20	5.54	3.57	1230	85	6.18	5.86	5.37	1790	86	10.70	6.40	9.58	3190	88
20.	170	2.39	3.17	1.98	735	83	3.99	5.48	3.40	1260	85	5.76	6.09	4.96	1880	86	9.98	6.93	8.93	3370	88
22.	158	2.23	2.10	1.64	652	73	3.49	4.09	2.66	1060	76	7.24	3.25	5.79	2350	76	11.20	3.48	9.13	3680	72
25.	139	2.07	2.48	1.52	686	73	3.24	3.98	2.47	1120	76	6.86	4.39	5.47	2450	78	10.40	4.31	8.54	3860	76
28.	123	1.92	2.88	1.41	721	73	3.01	3.86	2.28	1170	76	6.40	4.60	5.08	2580	78	9.77	4.68	7.98	4050	78
32.	104	1.68	2.70	1.37	833	82	2.82	4.76	2.34	1420	83	4.48	6.16	3.81	2230	85	7.58	7.99	6.72	4050	89
36.	96	1.63	2.57	1.18	776	73	2.61	4.02	1.95	1280	75	5.58	4.75	4.37	2820	78	8.50	6.90	6.91	4450	81
40.	89	1.56	2.47	1.12	794	72	2.49	3.88	1.85	1310	74	5.14	4.72	4.00	2930	77	7.90	6.75	6.41	4680	81
45.	77	1.36	2.28	1.09	896	80	2.26	4.09	1.86	1520	82	3.60	5.50	3.01	2540	84	6.14	8.18	5.39	4590	88
50.	66	1.21	2.06	0.97	927	80	2.01	3.69	1.64	1570	81	3.42	5.26	2.85	2610	83	5.90	8.18	5.17	4700	88
56.	62	1.22	1.82	0.87	878	71	1.96	3.12	1.43	1450	73	4.16	4.37	3.17	3160	76	6.57	5.85	5.25	5270	80
63.	55	1.12	1.85	0.79	912	70	1.80	3.04	1.30	1500	72	3.81	4.12	2.87	3260	75	5.94	6.46	4.72	5500	79
71.	47	1.00	1.88	0.79	1060	79	1.67	3.28	1.34	1800	80	2.72	4.61	2.23	2950	82	4.66	8.00	4.03	5360	86
80.	42	0.92	1.80	0.72	1080	79	1.47	3.12	1.18	1760	80	2.53	4.46	2.06	3070	82	4.40	7.79	3.79	5520	86
90.	40	0.96	1.70	0.67	1040	69	1.54	2.84	1.10	1710	71	3.06	3.67	2.24	3660	73	4.83	6.26	3.76	6190	78
100	34	0.85	1.55	0.58	1060	68	1.37	2.73	0.96	1750	70	2.88	3.64	2.10	3730	73	4.59	6.19	3.56	6260	77
112	31	0.72	1.57	0.56	1150	78	0.90	2.60	0.71	1450	78	1.92	4.04	1.55	3040	81	3.60	6.94	3.06	6090	85
125	27	0.66	1.44	0.51	1190	78	0.69	2.33	0.53	1250	78	1.46	3.74	1.17	2620	80	2.56	6.57	2.16	4820	84
140	25	0.66	1.39	0.44	1130	67	1.06	2.45	0.73	1860	69	2.16	3.37	1.53	3920	71	3.40	5.66	2.56	6600	75
160	22	0.61	1.33	0.41	1160	67	0.98	2.34	0.67	1900	68	1.98	3.23	1.39	4010	70	3.16	5.50	2.37	6690	75
212	16	0.49	1.12	0.32	1240	65	0.78	2.01	0.52	2030	67	1.61	2.83	1.11	4230	69	2.51	4.84	1.84	7080	73
250	14	0.44	1.02	0.29	1270	64	0.69	1.85	0.45	2010	66	1.46	2.58	1.00	4320	68	2.30	4.55	1.67	7230	73

Ratio Code *	Approx Output rpm	SIZE 07					SIZE 08					SIZE 09					SIZE 10				
		Horsepower			Mech Output Torque (lb-in)	Eff %	Horsepower			Mech Output Torque (lb-in)	Eff %	Horsepower			Mech Output Torque (lb-in)	Eff %	Horsepower			Mech Output Torque (lb-in)	Eff %
		Mech Input	Therm Input ‡	Mech Output			Mech Input	Therm Input ‡	Mech Output			Mech Input	Therm Input ‡	Mech Output			Mech Input	Therm Input ‡	Mech Output		
8.0	407	29.40	...	26.60	3780	90	52.60	...	47.60	6660	91	93.90	...	85.70	12300	91	164.00	24.60	151.00	21600	68
11.	301	24.60	...	22.50	4430	91	43.60	...	39.90	7920	92	79.40	...	73.40	14500	92	138.00	62.10	128.00	25600	89
12.	265	23.10	...	21.10	4680	92	41.20	...	37.80	8330	92	74.70	23.80	69.10	15300	86	132.00	69.80	123.00	26700	90
14.	234	21.90	...	20.10	4880	92	38.90	3.25	35.70	8750	58	70.10	34.60	65.20	16200	90	123.00	76.30	115.00	28300	92
16.	214	19.60	...	16.80	4770	86	35.00	...	30.20	8440	86	61.00	12.40	52.60	15800	60	109.00	24.50	95.50	28600	67
18.	183	18.90	3.21	17.30	5500	80	33.70	7.77	31.00	9830	83	61.00	38.40	56.50	18100	92	106.00	74.70	99.50	32000	92
20.	170	17.50	5.16	16.10	5810	86	31.50	10.10	29.00	10300	87	57.30	38.60	53.10	19000	92	102.00	76.10	95.30	33100	93
22.	158	15.90	...	13.80	5430	87	28.50	2.93	24.90	9870	40	50.60	22.50	44.30	18300	81	89.40	44.50	79.60	33300	84
25.	139	14.60	2.80	12.70	5620	66	26.80	8.23	23.40	10300	76	47.40	24.70	41.40	19200	83	85.10	48.70	76.10	34600	86
28.	123	13.60	4.50	11.90	5770	78	25.10	12.10	22.00	10800	82	44.20	26.60	38.80	20200	85	78.90	47.40	70.70	36500	87
32.	104	13.60	11.10	12.40	6900	91	23.90	14.70	21.90	12500	91	43.80	36.50	40.50	22900	92	76.30	72.10	71.20	40800	93
36.	96	11.20	6.79	9.75	6200	85	21.50	15.40	18.90	12000	86	38.00	30.30	33.40	22400	87	67.40	43.70	60.50	40700	88
40.	89	10.20	7.05	8.90	6430	85	20.00	16.20	17.60	12500	87	35.50	30.80	31.30	23400	88	64.30	46.10	57.80	42000	89
45.	77	10.90	11.90	9.92	7880	91	19.70	16.30	17.90	14100	91	35.50	33.00	32.70	26200	92	63.10	69.70	58.70	46100	93
50.	66	10.20	11.50	9.17	8240	90	18.30	16.00	16.70	14800	91	33.30	31.90	30.60	27300	92	59.20	67.20	54.90	47900	93
56.	62	8.29	7.97	7.19	6940	87	16.40	16.60	14.40	14200	88	29.10	31.20	25.60	26600	88	51.10	41.30	45.90	48600	89
63.	55	7.49	7.69	6.46	7170	86	14.90	15.70	13.00	14900	87	26.90	30.20	23.60	27900	88	46.70	40.20	41.80	50100	89
71.	47	8.31	10.40	7.43	9230	89	14.80	14.40	13.30	16700	90	26.90	28.80	24.60	30900	91	47.60	57.00	43.80	54600	92
80.	42	7.85	10.40	7.00	9520	89	14.00	14.10	12.60	17300	90	25.30	27.00	23.00	32000	91	43.60	51.70	40.00	57400	92
90.	40	5.73	6.96	4.89	7770	85	11.80	14.50	10.20	16000	86	21.70	27.70	18.90	31700	87	36.80	38.00	32.70	53700	89
100	34	5.22	6.53	4.44	7970	85	10.70	13.80	9.25	16400	86	20.40	26.80	17.70	32900	87	34.00	36.40	30.10	54900	88
112	31	6.39	8.82	5.64	1060	88	11.60	13.10	10.30	19000	89	20.70	24.40	18.60	35600	90	36.10	42.80	32.80	63700	91
125	27	5.16	8.07	4.52	9440	88	10.60	12.50	9.38	19900	88	18.80	22.80	16.80	36200	90	34.60	41.00	31.30	65200	90
140	25	4.07	5.63	3.41	8470	84	8.23	12.30	6.98	17500	85	16.50	23.70	14.10	37000	85	25.80	30.40	22.60	58800	87
160	22	3.79	5.39	3.17	8610	84	7.64	12.20	6.46	17800	85	15.40	23.20	13.10	38200	85	23.10	28.40	20.10	60300	87
212	16	2.94	4.20	2.41	9070	82	6.06	11.00	5.07	18700	84	12.50	19.90	10.50	42000	84	18.20	24.20	15.60	63300	86
250	14	2.70	3.90	2.21	9220	82	5.43	10.80	4.50	19100	83	11.60	19.40	9.65	43400	83	17.20	24.60	14.70	63900	85

* Refer to Page 14 for exact ratios.
 ‡ Refer to Page 6 for Reference Note.

UW – Gear Drive Horsepower & Torque Ratings

3500 High Speed Shaft rpm/Triple Reduction

Ratio Code ★	Approx Output rpm	SIZE 03					SIZE 04					SIZE 05				
		Horsepower			Mech Output Torque (lb-in)	Eff %	Horsepower			Mech Output Torque (lb-in)	Eff %	Horsepower			Mech Output Torque (lb-in)	Eff %
		Mech Input	Therm Input ‡	Mech Output			Mech Input	Therm Input ‡	Mech Output			Mech Input	Therm Input ‡	Mech Output		
100	33	0.73	1.12	0.55	1050	76	1.20	2.05	0.93	1770	78	2.20	3.05	1.76	3290	80
118	29	0.67	1.07	0.51	1100	76	1.10	1.98	0.85	1840	77	2.01	2.87	1.60	3430	80
132	27	0.68	1.08	0.44	1020	64	1.08	1.91	0.71	1670	66	2.16	2.55	1.51	3550	70
150	25	0.65	1.06	0.41	1040	64	1.02	1.86	0.67	1700	66	2.05	2.53	1.43	3610	70
160	22	0.55	0.92	0.41	1210	75	0.82	1.78	0.63	1830	76	1.59	2.30	1.25	3610	79
180	18	0.50	0.97	0.37	1280	75	0.70	1.64	0.53	1820	76	1.36	2.17	1.06	3590	78
200	17	0.50	0.93	0.31	1130	63	0.78	1.58	0.51	1830	65	1.56	2.32	1.07	3860	68
225	15	0.46	0.87	0.29	1180	63	0.72	1.45	0.46	1900	64	1.42	2.19	0.96	3980	68
265	13	0.39	0.77	0.28	1360	74	0.50	1.28	0.38	1800	75	0.97	1.76	0.75	3540	77
280	12	0.35	0.69	0.26	1360	73	0.45	1.15	0.34	1790	74	0.88	1.62	0.67	3530	77
315	11	0.38	0.77	0.23	1300	62	0.60	1.31	0.38	2100	63	1.17	1.78	0.78	4350	67
360	10	0.34	0.70	0.21	1360	61	0.54	1.21	0.34	2220	63	1.06	1.64	0.70	4560	66
400	8.6	0.25	0.54	0.19	1360	73	0.33	0.88	0.24	1770	74	0.63	1.32	0.48	3490	76
450	7.5	0.23	0.49	0.16	1360	72	0.29	0.76	0.21	1770	73	0.56	1.14	0.42	3480	76
500	6.9	0.25	0.52	0.15	1360	60	0.44	0.96	0.27	2480	62	0.85	1.25	0.55	5010	64
560	6.2	0.22	0.48	0.13	1360	60	0.41	0.92	0.25	2570	62	0.78	1.15	0.50	5100	64
800	4.5	0.17	0.38	0.10	1360	59	0.33	0.74	0.20	2780	61	0.60	0.92	0.38	5260	63
900	4.0	0.15	0.33	0.09	1360	59	0.29	0.65	0.17	2760	60	0.53	0.80	0.33	5260	62

Ratio Code ★	Approx Output rpm	SIZE 06					SIZE 07				
		Horsepower			Mech Output Torque (lb-in)	Eff %	Horsepower			Mech Output Torque (lb-in)	Eff %
		Mech Input	Therm Input ‡	Mech Output			Mech Input	Therm Input ‡	Mech Output		
100	33	3.79	5.69	3.20	5980	84	6.76	6.51	5.88	10300	87
118	29	3.48	5.48	2.92	6210	84	6.12	6.02	5.30	10800	87
132	27	3.42	4.23	2.53	5930	74	4.53	7.15	3.70	8320	82
150	25	3.10	4.17	2.29	6080	74	4.10	6.50	3.34	8510	81
160	22	2.72	4.67	2.25	6890	83	4.83	4.83	4.17	12000	86
180	18	2.56	4.45	2.12	7050	83	4.58	4.65	3.94	12100	86
200	17	2.46	3.91	1.78	6440	72	3.18	5.18	2.56	8980	81
225	15	2.23	3.76	1.61	6600	72	2.81	4.67	2.26	9190	80
265	13	1.92	3.24	1.57	7520	82	3.17	3.43	2.69	12100	85
280	12	1.72	2.76	1.39	7520	81	2.90	3.19	2.46	12100	85
315	11	1.75	3.22	1.23	7290	70	2.15	3.88	1.71	9830	79
360	10	1.66	3.07	1.16	7480	70	2.04	3.75	1.62	9950	79
400	8.6	1.31	2.45	1.06	7520	81	2.15	2.44	1.80	12100	84
450	7.5	1.16	2.16	0.93	7520	80	1.92	2.22	1.60	12100	84
500	6.9	1.19	2.24	0.81	7520	68	1.51	2.97	1.18	10600	78
560	6.2	1.07	2.07	0.72	7520	67	1.40	2.75	1.10	10800	78
800	4.5	0.82	1.74	0.55	7520	67	1.09	2.08	0.84	11300	77
900	4.0	0.73	1.56	0.48	7520	66	0.97	1.88	0.75	11300	77

★ Refer to Page 14 for exact ratios.

‡ Refer to Page 6 for Reference Note.

UW – Gear Drive Horsepower & Torque Ratings

2400 High Speed Shaft rpm/Double Reduction

Ratio Code *	Approx Output rpm	SIZE 03					SIZE 04					SIZE 05					SIZE 06				
		Horsepower			Mech Output Torque (lb-in)	Eff %	Horsepower			Mech Output Torque (lb-in)	Eff %	Horsepower			Mech Output Torque (lb-in)	Eff %	Horsepower			Mech Output Torque (lb-in)	Eff %
		Mech Input	Therm Input ‡	Mech Output			Mech Input	Therm Input ‡	Mech Output			Mech Input	Therm Input ‡	Mech Output			Mech Input	Therm Input ‡	Mech Output		
8.0	279	3.33	4.06	2.79	630	84	5.41	5.14	4.66	1050	86	7.76	7.21	6.78	1480	87	13.60	7.19	12.20	2640	87
11.	207	2.71	3.56	2.27	691	84	4.51	5.08	3.87	1180	86	6.47	6.85	5.62	1720	87	11.20	7.44	10.10	3070	88
12.	182	2.47	3.29	2.06	713	83	4.11	4.99	3.49	1210	85	6.13	6.56	5.31	1790	87	10.50	6.89	9.46	3220	89
14.	161	2.27	2.99	1.88	739	83	3.78	4.88	3.21	1260	85	5.71	6.66	4.94	1890	86	9.87	6.10	8.84	3380	88
16.	147	2.11	1.91	1.56	668	73	3.30	3.41	2.51	1080	76	7.06	3.94	5.66	2390	78	10.90	4.15	8.94	3740	76
18.	125	1.90	2.32	1.56	785	82	3.17	4.61	2.67	1340	84	4.98	6.55	4.28	2080	86	8.59	6.79	7.66	3720	89
20.	116	1.80	2.57	1.48	802	82	3.01	4.51	2.53	1370	84	4.62	6.44	3.95	2180	85	7.98	6.89	7.11	3910	89
22.	109	1.75	1.82	1.28	741	73	2.78	3.19	2.10	1220	76	5.86	4.44	4.63	2740	78	8.93	4.45	7.31	4300	79
25.	95	1.60	2.06	1.16	767	73	2.55	3.08	1.92	1270	75	5.54	5.07	4.34	2830	78	8.36	4.83	6.81	4490	80
28.	84	1.47	2.31	1.06	795	72	2.35	2.97	1.75	1310	75	5.06	5.00	3.94	2920	78	7.81	4.91	6.35	4700	80
32.	71	1.27	2.11	1.02	903	80	2.11	3.76	1.73	1530	82	3.56	5.75	2.98	2550	84	6.01	6.88	5.28	4640	88
36.	66	1.25	2.04	0.89	850	71	1.99	3.04	1.46	1400	74	4.27	4.77	3.27	3080	77	6.80	6.15	5.47	5140	80
40.	61	1.19	1.95	0.84	869	71	1.90	2.93	1.39	1430	73	3.91	4.60	2.96	3170	76	6.23	5.91	4.99	5310	80
45.	53	1.02	1.76	0.81	969	80	1.70	3.18	1.38	1650	81	2.84	4.86	2.34	2880	82	4.85	6.64	4.21	5230	87
50.	45	0.91	1.58	0.72	1000	79	1.51	2.85	1.21	1700	80	2.69	4.61	2.21	2960	82	4.65	6.58	4.03	5350	87
56.	43	0.93	1.43	0.64	950	69	1.48	2.34	1.06	1560	71	3.13	4.04	2.32	3380	74	4.94	4.99	3.88	5680	79
63.	37	0.85	1.44	0.58	983	69	1.35	2.27	0.96	1610	71	2.84	3.76	2.09	3460	74	4.41	5.31	3.43	5830	78
71.	32	0.75	1.41	0.58	1140	78	1.20	2.49	0.95	1860	79	2.13	3.88	1.72	3320	81	3.64	6.19	3.12	6050	86
80.	29	0.69	1.35	0.54	1170	78	1.01	2.36	0.80	1730	79	1.97	3.70	1.59	3440	80	3.43	5.99	2.92	6210	85
90.	28	0.72	1.30	0.48	1100	68	1.15	2.10	0.80	1810	69	2.28	3.20	1.63	3880	72	3.57	4.97	2.72	6540	76
100	24	0.64	1.18	0.43	1140	67	1.02	2.00	0.70	1870	69	2.14	3.13	1.52	3930	71	3.39	4.89	2.57	6600	76
112	21	0.54	1.16	0.42	1250	77	0.64	1.95	0.49	1480	78	1.32	3.27	1.05	3010	80	2.76	5.25	2.32	6730	84
125	18	0.49	1.07	0.37	1260	76	0.49	1.74	0.37	1270	77	1.01	3.01	0.80	2590	79	1.75	4.95	1.46	4760	84
140	17	0.50	1.05	0.33	1230	66	0.81	1.78	0.54	2010	67	1.63	2.78	1.13	4210	69	2.55	4.36	1.88	7060	74
160	15	0.47	1.00	0.30	1250	65	0.75	1.71	0.50	2050	66	1.49	2.64	1.03	4310	69	2.38	4.21	1.75	7180	73
212	11	0.37	0.83	0.23	1340	64	0.59	1.45	0.38	2190	65	1.21	2.27	0.82	4540	68	1.87	3.66	1.34	7520	72
250	10	0.33	0.75	0.21	1360	63	0.49	1.33	0.31	2030	64	1.01	2.06	0.67	4240	67	1.68	3.43	1.19	7520	71

Ratio Code *	Approx Output rpm	SIZE 07					SIZE 08					SIZE 09					SIZE 10				
		Horsepower			Mech Output Torque (lb-in)	Eff %	Horsepower			Mech Output Torque (lb-in)	Eff %	Horsepower			Mech Output Torque (lb-in)	Eff %	Horsepower			Mech Output Torque (lb-in)	Eff %
		Mech Input	Therm Input ‡	Mech Output			Mech Input	Therm Input ‡	Mech Output			Mech Input	Therm Input ‡	Mech Output			Mech Input	Therm Input ‡	Mech Output		
8.0	279	23.80	...	21.90	4540	92	42.80	...	39.40	8030	92	76.60	...	71.20	14900	93	134.00	27.80	125.00	26100	83
11.	207	19.90	...	18.30	5260	92	35.30	...	32.70	9440	92	64.40	5.60	60.00	17300	69	112.00	50.80	105.00	30600	91
12.	182	18.60	2.38	17.10	5530	77	33.30	4.48	30.80	9890	78	60.50	24.00	56.40	18200	90	107.00	55.40	100.00	31800	92
14.	161	17.60	5.34	16.20	5760	88	31.40	9.26	28.80	10300	87	56.60	30.60	52.70	19100	92	99.60	59.10	93.30	33600	93
16.	147	15.20	...	13.30	5520	88	27.80	...	24.50	9990	88	48.60	13.80	42.90	18800	77	86.70	21.50	77.60	33900	78
18.	125	15.10	7.77	13.90	6430	90	27.00	10.80	24.90	11500	90	48.90	31.80	45.60	21300	92	85.60	56.60	80.20	37600	93
20.	116	14.00	8.47	12.80	6760	91	25.20	11.80	23.30	12100	91	45.80	31.40	42.50	22200	92	81.90	57.30	76.60	38800	93
22.	109	12.00	4.99	10.50	6030	82	22.60	6.33	19.90	11500	79	40.20	19.50	35.70	21500	85	71.10	34.30	64.10	39100	87
25.	95	11.00	5.95	9.64	6220	85	21.20	9.60	18.70	12000	84	37.60	20.60	33.30	22500	86	67.60	36.90	61.10	40500	88
28.	84	10.30	6.79	9.00	6390	86	19.90	11.90	17.50	12500	86	35.10	21.60	31.00	23500	87	62.70	35.70	56.50	42600	88
32.	71	10.80	10.90	9.81	7930	91	18.90	13.30	17.30	14400	91	34.80	28.30	32.10	26500	92	60.60	52.70	56.30	47100	93
36.	66	8.50	7.56	7.41	6870	87	17.00	13.50	14.90	13800	87	30.10	23.50	26.60	26000	88	53.40	32.60	48.10	47200	88
40.	61	7.75	7.43	6.73	7090	87	15.80	13.70	13.90	14400	88	28.10	23.60	24.80	27100	88	51.00	34.10	45.90	48600	89
45.	53	8.65	10.60	7.78	9010	90	15.60	13.60	14.10	16200	90	28.10	25.00	25.70	30100	92	50.00	50.40	46.30	53000	93
50.	45	8.01	9.99	7.18	9400	90	14.50	13.10	13.10	16900	90	26.30	24.10	24.00	31200	91	46.90	48.40	43.20	55000	92
56.	43	6.25	7.47	5.38	7580	86	12.50	13.30	11.00	15700	88	23.10	23.40	20.20	30600	88	38.50	30.20	34.30	53000	89
63.	37	5.63	7.04	4.82	7800	86	11.20	12.50	9.71	16200	87	21.30	22.50	18.50	32000	87	35.00	29.30	31.10	54400	89
71.	32	6.51	8.74	5.74	10400	88	11.60	11.40	10.40	19000	89	21.20	21.40	19.10	35100	90	37.50	40.90	34.30	62300	91
80.	29	6.14	8.61	5.44	10800	89	10.90	11.10	9.71	19500	89	19.60	20.00	17.70	35900	90	34.30	37.10	31.20	65300	91
90.	28	4.28	6.06	3.61	8370	84	8.79	11.30	7.51	17200	85	17.20	20.40	14.80	36100	86	27.40	27.50	34.20	57900	88
100	24	3.89	5.63	3.26	8550	84	8.00	10.70	6.81	17600	85	16.10	19.60	13.80	37400	85	25.30	26.30	22.10	59000	88
112	21	4.79	7.13	4.16	11400	87	9.01	10.10	7.93	21300	88	15.00	17.90	13.40	37300	89	28.20	30.60	25.30	71700	90
125	18	3.54	6.51	3.07	9340	87	8.20	9.56	7.17	22200	87	13.60	16.70	12.10	37800	89	26.30	29.30	23.60	71600	90
140	17	3.01	4.72	2.49	9020	83	6.09	9.33	5.09	18600	84	12.90	17.30	10.80	41500	84	19.10	21.90	16.50	62600	86
160	15	2.80	4.49	2.31	9150	82	5.65	9.22	4.71	18900	83	12.00	16.90	10.10	42700	84	17.00	20.40	14.60	64000	86
212	11	2.19	3.46	1.78	9740	81	4.52	8.21	3.72	20000	82	9.66	14.40	7.96	46400	82	13.60	17.30	11.50	67900	84
250	10	2.02	3.21	1.63	9930	81	4.07	7.97	3.33	20600	82	8.91	14.00	7.29	47800	82	12.90	17.60	10.80	68900	84

* Refer to Page 14 for exact ratios.
 ‡ Refer to Page 6 for Reference Note.

UW – Gear Drive Horsepower & Torque Ratings

2400 High Speed Shaft rpm/Triple Reduction

Ratio Code ★	Approx Output rpm	SIZE 03					SIZE 04					SIZE 05				
		Horsepower			Mech Output Torque (lb-in)	Eff %	Horsepower			Mech Output Torque (lb-in)	Eff %	Horsepower			Mech Output Torque (lb-in)	Eff %
		Mech Input	Therm Input ‡	Mech Output			Mech Input	Therm Input ‡	Mech Output			Mech Input	Therm Input ‡	Mech Output		
100	23	0.57	0.86	0.43	1190	75	0.87	1.57	0.67	1840	77	1.68	2.60	1.32	3610	79
118	20	0.52	0.81	0.39	1240	75	0.76	1.50	0.58	1830	76	1.47	2.42	1.16	3600	79
132	18	0.51	0.83	0.33	1110	63	0.81	1.41	0.53	1810	65	1.63	2.23	1.12	3820	68
150	17	0.49	0.81	0.31	1140	63	0.77	1.37	0.50	1840	65	1.54	2.19	1.05	3870	68
160	15	0.43	0.69	0.32	1360	74	0.56	1.33	0.42	1810	76	1.09	1.92	0.85	3560	78
180	13	0.37	0.72	0.27	1360	74	0.48	1.23	0.36	1800	75	0.93	1.78	0.72	3540	77
200	12	0.39	0.70	0.24	1280	62	0.61	1.15	0.39	2070	64	1.21	1.92	0.81	4280	67
225	10	0.36	0.65	0.22	1340	62	0.56	1.06	0.36	2160	64	1.11	1.80	0.74	4450	66
265	9.0	0.27	0.56	0.20	1360	73	0.34	0.95	0.26	1780	74	0.67	1.42	0.51	3500	76
280	8.1	0.24	0.51	0.18	1360	73	0.31	0.85	0.23	1770	74	0.60	1.31	0.46	3490	76
315	7.8	0.28	0.57	0.17	1360	61	0.47	0.95	0.29	2380	62	0.92	1.45	0.60	4870	65
360	6.6	0.24	0.52	0.14	1360	60	0.43	0.88	0.26	2510	62	0.82	1.32	0.53	5050	65
400	5.9	0.18	0.39	0.13	1360	72	0.22	0.65	0.16	1750	73	0.43	1.04	0.33	3450	75
450	5.2	0.16	0.36	0.11	1360	72	0.20	0.57	0.14	1750	73	0.38	0.91	0.29	3440	75
500	4.7	0.17	0.38	0.10	1360	59	0.34	0.69	0.21	2790	61	0.62	1.00	0.39	5260	63
560	4.3	0.16	0.35	0.09	1360	59	0.31	0.66	0.19	2770	60	0.56	0.92	0.36	5260	63
800	3.1	0.11	0.28	0.07	1360	58	0.22	0.53	0.13	2730	60	0.42	0.73	0.26	5260	62
900	2.7	0.10	0.24	0.06	1360	58	0.20	0.47	0.12	2710	59	0.37	0.63	0.23	5260	61

Ratio Code ★	Approx Output rpm	SIZE 06					SIZE 07				
		Horsepower			Mech Output Torque (lb-in)	Eff %	Horsepower			Mech Output Torque (lb-in)	Eff %
		Mech Input	Therm Input ‡	Mech Output			Mech Input	Therm Input ‡	Mech Output		
100	23	2.93	4.41	2.45	6680	84	5.23	5.22	4.54	11600	87
118	20	2.68	4.21	2.23	6920	83	4.71	4.70	4.07	12100	87
132	18	2.56	3.38	1.87	6370	73	3.33	5.40	2.71	8880	81
150	17	2.33	3.29	1.68	6530	72	3.01	4.95	2.43	9060	81
160	15	2.05	3.53	1.69	7520	82	3.37	3.61	2.88	12100	86
180	13	1.89	3.35	1.55	7520	82	3.17	3.44	2.70	12100	85
200	12	1.88	3.02	1.34	7050	71	2.35	4.11	1.88	9610	80
225	10	1.73	2.89	1.22	7320	71	2.09	3.80	1.66	9890	80
265	9.0	1.33	2.43	1.08	7520	81	2.19	2.49	1.84	12100	84
280	8.1	1.19	2.08	0.96	7520	80	2.01	2.30	1.68	12100	84
315	7.8	1.27	2.44	0.87	7520	69	1.59	3.13	1.25	10500	79
360	6.6	1.17	2.32	0.80	7520	69	1.51	2.97	1.18	10600	78
400	5.9	0.91	1.82	0.73	7520	80	1.48	1.74	1.23	12100	83
450	5.2	0.80	1.61	0.64	7520	79	1.33	1.57	1.10	12100	83
500	4.7	0.83	1.69	0.56	7520	67	1.11	2.12	0.86	11300	78
560	4.3	0.75	1.55	0.49	7520	66	1.02	1.96	0.79	11300	77
800	3.1	0.57	1.30	0.37	7520	65	0.75	1.47	0.57	11200	76
900	2.7	0.51	1.16	0.33	7520	65	0.67	1.33	0.51	11200	76

★ Refer to Page 14 for exact ratios.
‡ Refer to Page 6 for Reference Note.

UW – Gear Drive Horsepower & Torque Ratings

1750 High Speed Shaft rpm/Double Reduction

Ratio Code ★	Approx Output rpm	SIZE 03					SIZE 04					SIZE 05					SIZE 06				
		Horsepower			Mech Output Torque (lb-in)	Eff %	Horsepower			Mech Output Torque (lb-in)	Eff %	Horsepower			Mech Output Torque (lb-in)	Eff %	Horsepower			Mech Output Torque (lb-in)	Eff %
		Mech Input	Therm Input ‡	Mech Output			Mech Input	Therm Input ‡	Mech Output			Mech Input	Therm Input ‡	Mech Output			Mech Input	Therm Input ‡	Mech Output		
8.0	204	2.65	3.35	2.21	685	84	4.39	4.48	3.75	1160	85	6.54	7.63	5.71	1710	87	11.40	7.50	10.30	3040	89
11.	151	2.14	2.90	1.78	744	83	3.57	4.27	3.02	1260	84	5.41	6.74	4.67	1960	86	9.38	7.07	8.42	3510	89
12.	133	1.95	2.67	1.61	767	83	3.25	4.15	2.74	1300	84	5.12	6.38	4.41	2040	86	8.77	6.51	7.86	3670	89
14.	117	1.79	2.42	1.47	794	82	2.99	4.02	2.51	1350	84	4.75	6.28	4.07	2140	86	8.20	5.77	7.33	3840	89
16.	107	1.70	1.62	1.25	736	73	2.72	2.72	2.05	1210	76	5.92	4.23	4.68	2710	78	9.03	4.28	7.43	4260	79
18.	91	1.50	1.88	1.23	845	82	2.50	3.73	2.08	1430	83	4.13	5.93	3.51	2340	85	7.10	6.03	6.31	4200	88
20.	85	1.43	2.05	1.16	861	81	2.37	3.64	1.97	1460	83	3.82	5.72	3.23	2450	85	6.58	5.99	5.83	4400	88
22.	79	1.39	1.51	1.01	801	72	2.23	2.52	1.66	1320	74	4.71	4.27	3.64	2960	77	7.41	4.19	6.01	4850	80
25.	70	1.28	1.68	0.92	828	71	2.04	2.43	1.50	1360	74	4.40	4.66	3.38	3030	77	6.93	4.39	5.60	5060	80
28.	61	1.17	1.85	0.84	857	71	1.88	2.33	1.38	1410	73	4.02	4.52	3.06	3110	76	6.38	4.37	5.13	5200	80
32.	52	1.00	1.66	0.80	965	80	1.66	2.97	1.35	1640	81	2.89	4.88	2.40	2810	83	4.93	5.65	4.30	5180	87
36.	48	0.99	1.62	0.70	913	70	1.59	2.36	1.14	1500	72	3.39	4.19	2.54	3280	75	5.38	5.16	4.26	5490	79
40.	45	0.94	1.55	0.66	931	70	1.51	2.27	1.08	1530	72	3.07	3.99	2.28	3350	74	4.88	4.91	3.84	5610	79
45.	38	0.80	1.37	0.64	1040	79	1.34	2.49	1.07	1760	80	2.21	4.04	1.81	3050	82	3.95	5.31	3.41	5810	86
50.	33	0.71	1.23	0.56	1070	78	1.19	2.23	0.95	1820	80	2.08	3.82	1.69	3100	81	3.79	5.25	3.26	5930	86
56.	31	0.74	1.14	0.50	1020	69	1.18	1.81	0.83	1670	70	2.46	3.44	1.79	3570	73	3.85	4.10	2.97	5960	77
63.	27	0.67	1.13	0.45	1050	68	1.07	1.75	0.74	1720	70	2.25	3.18	1.62	3670	72	3.46	4.29	2.64	6160	76
71.	23	0.59	1.09	0.46	1220	77	0.88	1.93	0.69	1840	78	1.51	3.16	1.21	3190	80	2.83	4.83	2.39	6370	85
80.	21	0.54	1.04	0.42	1250	77	0.74	1.83	0.57	1710	78	1.36	2.99	1.08	3220	80	2.61	4.66	2.21	6430	85
90.	20	0.57	1.02	0.38	1180	66	0.91	1.61	0.62	1930	68	1.79	2.65	1.26	4110	70	2.80	3.95	2.09	6880	75
100	17	0.51	0.21	0.33	1220	64	0.81	0.37	0.54	1990	66	1.69	2.58	1.18	4180	70	2.66	3.87	1.98	6970	74
112	15	0.44	0.13	0.33	1360	75	0.48	0.23	0.36	1500	76	0.99	2.61	0.78	3050	79	2.01	4.06	1.67	6660	83
125	13	0.36	0.12	0.28	1290	74	0.36	0.21	0.28	1290	75	0.75	2.40	0.59	2630	78	1.28	3.82	1.06	4720	83
140	12	0.40	0.22	0.26	1310	63	0.64	0.39	0.42	2140	65	1.29	2.24	0.87	4470	68	2.01	3.41	1.45	7490	72
160	11	0.37	0.12	0.24	1340	61	0.59	0.22	0.39	2190	64	1.18	2.12	0.79	4570	67	1.86	3.29	1.33	7520	72
212	8.0	0.28	0.15	0.17	1360	62	0.47	0.27	0.30	2370	63	0.96	1.81	0.63	4820	66	1.39	2.84	0.98	7520	70
250	7.1	0.25	0.13	0.15	1360	62	0.36	0.24	0.23	2050	63	0.75	1.64	0.49	4270	66	1.25	2.66	0.87	7520	70

Ratio Code ★	Approx Output rpm	SIZE 07					SIZE 08					SIZE 09					SIZE 10				
		Horsepower			Mech Output Torque (lb-in)	Eff %	Horsepower			Mech Output Torque (lb-in)	Eff %	Horsepower			Mech Output Torque (lb-in)	Eff %	Horsepower			Mech Output Torque (lb-in)	Eff %
		Mech Input	Therm Input ‡	Mech Output			Mech Input	Therm Input ‡	Mech Output			Mech Input	Therm Input ‡	Mech Output			Mech Input	Therm Input ‡	Mech Output		
8.0	204	20.00	24.80	18.40	5240	92	35.90	38.70	33.20	9300	93	64.40	62.00	60.30	17300	93	113.00	109.00	106.00	30400	93
11.	151	16.60	19.00	15.30	6020	92	29.50	29.50	27.20	10800	92	53.80	49.10	50.10	19800	93	93.70	85.60	88.00	35200	94
12.	133	15.50	17.20	14.30	6310	92	27.70	27.20	25.70	11300	93	50.40	45.00	47.00	20800	93	89.30	80.60	83.90	36500	94
14.	117	14.60	16.00	13.50	3550	92	26.00	25.00	24.10	11800	92	47.10	41.30	43.90	21800	93	83.00	73.50	77.70	38400	94
16.	107	12.00	16.40	10.60	6020	88	22.90	25.80	20.40	11400	89	40.20	36.40	35.60	21400	89	71.70	69.70	64.80	38800	90
18.	91	12.50	12.80	11.40	7260	91	22.30	20.40	20.50	13000	92	40.50	34.00	37.60	24100	93	70.90	60.10	66.40	42700	93
20.	85	11.50	11.70	10.50	7620	92	20.80	18.60	19.10	13600	91	37.90	31.20	35.10	25100	92	67.80	57.10	63.20	43900	93
22.	79	9.52	12.80	8.35	6580	88	18.60	20.00	16.50	13100	89	33.20	29.40	29.40	24300	88	58.70	55.90	53.10	44400	90
25.	70	8.76	12.50	7.66	6780	87	17.40	19.70	15.40	13600	89	31.00	29.00	27.40	25400	89	55.80	56.50	50.40	45800	90
28.	61	8.18	12.10	7.14	6950	87	16.30	19.00	14.40	14100	88	28.90	27.80	25.60	26600	89	51.60	53.70	46.60	48100	90
32.	52	6.70	9.81	6.02	6680	90	15.60	15.00	14.20	16200	91	28.60	25.80	26.30	29700	92	49.90	44.80	46.20	53000	92
36.	48	6.72	9.60	5.83	7410	87	13.70	15.00	12.10	15300	88	24.80	22.40	21.80	29200	88	42.60	42.70	38.20	54100	90
40.	45	6.11	8.54	5.27	7620	86	12.60	13.70	11.00	15700	88	23.20	20.30	20.30	30400	87	40.20	39.90	36.00	52300	90
45.	38	5.15	7.38	4.58	7280	89	12.80	11.60	11.50	18000	89	23.00	19.10	21.00	33600	91	41.10	34.30	37.70	59300	92
50.	33	4.62	6.74	4.09	7350	89	11.80	10.50	10.60	18800	90	21.50	17.60	19.50	34800	91	37.60	31.40	34.40	60100	91
56.	31	4.91	6.66	4.19	8090	85	9.86	10.30	8.50	16700	86	18.90	15.30	16.50	34200	87	30.20	28.30	26.70	56600	88
63.	27	4.41	6.24	3.74	8300	85	8.78	9.50	7.52	17200	86	17.50	14.50	15.10	35700	86	27.40	27.40	24.10	57900	88
71.	23	3.56	5.58	3.12	7750	88	9.43	8.52	8.34	20900	88	16.30	14.10	14.70	36900	89	27.90	24.50	25.20	62800	90
80.	21	3.29	5.35	2.87	7820	87	8.85	5.35	7.81	20500	88	15.00	13.30	13.40	37300	90	24.50	22.60	22.10	63500	90
90.	20	3.33	4.75	2.78	8840	84	6.85	4.75	5.79	18200	85	14.00	10.90	11.90	39900	84	21.40	20.80	18.60	61200	87
100	17	3.02	4.36	2.51	9010	83	6.22	4.36	5.24	18600	84	13.10	9.99	11.10	41200	84	19.70	19.10	17.00	62200	87
112	15	2.50	4.64	2.16	8110	86	7.23	4.64	6.32	23300	88	11.40	11.40	10.10	38600	89	20.70	19.40	18.50	71700	89
125	13	2.25	4.46	1.94	8080	86	5.91	4.46	5.11	21700	87	10.30	10.90	9.07	39000	88	18.40	18.70	16.40	68200	89
140	12	2.35	3.64	1.92	9550	82	4.76	3.64	3.95	19800	83	10.40	8.07	8.59	45200	83	14.90	15.10	12.70	66300	85
160	11	2.19	3.50	1.79	9720	82	4.43	3.50	3.65	20100	82	9.65	7.67	7.98	46400	83	13.40	14.00	11.30	68100	85
212	8.0	1.71	3.07	1.37	10300	80	3.53	3.07	2.88	21200	81	7.70	6.62	6.25	50000	81	10.60	12.10	8.86	71900	84
250	7.1	1.58	2.95	1.26	10500	80	3.17	2.95	2.56	21700	81	7.08	6.31	5.71	51300	81	10.00	11.70	8.34	72700	83

★ Refer to Page 14 for exact ratios.
‡ Refer to Page 6 for Reference Note.

UW – Gear Drive Horsepower & Torque Ratings

1750 High Speed Shaft rpm/Triple Reduction

Ratio Code ★	Approx Output rpm	SIZE 03					SIZE 04					SIZE 05				
		Horsepower			Mech Output Torque (lb-in)	Eff %	Horsepower			Mech Output Torque (lb-in)	Eff %	Horsepower			Mech Output Torque (lb-in)	Eff %
		Mech Input	Therm Input ‡	Mech Output			Mech Input	Therm Input ‡	Mech Output			Mech Input	Therm Input ‡	Mech Output		
100	17	0.47	0.66	0.35	1320	75	0.63	1.22	0.48	1820	76	1.22	2.13	0.95	3570	78
118	15	0.42	0.63	0.31	1360	75	0.55	1.17	0.42	1810	76	1.07	1.97	0.83	3560	78
132	13	0.42	0.65	0.26	1230	63	0.66	1.07	0.43	1990	65	1.30	1.85	0.88	4130	68
150	12	0.40	0.63	0.25	1260	63	0.63	1.04	0.40	2040	64	1.24	1.81	0.83	4220	67
160	11	0.32	0.53	0.23	1360	74	0.41	1.03	0.31	1790	75	0.79	1.55	0.61	3520	77
180	9.2	0.27	0.55	0.20	1360	73	0.35	0.94	0.26	1780	74	0.68	1.43	0.52	3500	76
200	8.7	0.31	0.54	0.19	1360	62	0.50	0.88	0.32	2290	63	0.99	1.56	0.65	4700	66
225	7.6	0.27	0.50	0.17	1360	61	0.46	0.80	0.29	2400	63	0.91	1.45	0.59	4900	65
265	6.6	0.20	0.43	0.14	1360	72	0.25	0.73	0.18	1760	73	0.49	1.13	0.37	3460	75
280	5.9	0.18	0.39	0.13	1360	72	0.23	0.65	0.16	1750	73	0.44	1.04	0.33	3450	75
315	5.7	0.20	0.44	0.12	1360	60	0.39	0.72	0.24	2650	62	0.72	1.16	0.46	5170	64
360	4.8	0.18	0.40	0.10	1360	60	0.35	0.66	0.21	2790	61	0.63	1.05	0.40	5260	64
400	4.3	0.13	0.30	0.09	1360	72	0.16	0.49	0.12	1740	73	0.32	0.83	0.24	3420	74
450	3.8	0.11	0.27	0.08	1360	71	0.14	0.43	0.10	1730	72	0.28	0.72	0.21	3410	74
500	3.5	0.13	0.29	0.07	1360	59	0.25	0.52	0.15	2740	60	0.46	0.79	0.29	5260	62
560	3.1	0.12	0.27	0.07	1360	58	0.23	0.50	0.14	2730	60	0.42	0.73	0.26	5260	62
800	2.2	0.08	0.21	0.05	1360	58	0.16	0.40	0.10	2690	59	0.31	0.57	0.19	5260	61
900	2.0	0.07	0.18	0.04	1360	57	0.14	0.35	0.08	2670	58	0.27	0.50	0.17	5260	61

Ratio Code ★	Approx Output rpm	SIZE 06					SIZE 07				
		Horsepower			Mech Output Torque (lb-in)	Eff %	Horsepower			Mech Output Torque (lb-in)	Eff %
		Mech Input	Therm Input ‡	Mech Output			Mech Input	Therm Input ‡	Mech Output		
100	17	2.34	3.44	1.94	7270	83	4.01	4.81	3.45	12100	86
118	15	2.14	3.27	1.77	7500	83	3.46	4.52	2.97	12100	86
132	13	2.03	2.69	1.45	6800	72	2.58	3.87	2.08	9370	81
150	12	1.87	2.61	1.33	7060	71	2.34	3.65	1.88	9600	80
160	11	1.51	2.72	1.23	7520	81	2.48	3.97	2.10	12100	85
180	9.2	1.39	2.58	1.13	7520	81	2.33	3.88	1.97	12100	84
200	8.7	1.49	2.37	1.04	7520	70	1.83	3.18	1.46	10200	80
225	7.6	1.32	2.26	0.92	7520	69	1.62	3.00	1.28	10400	79
265	6.6	0.98	1.87	0.79	7520	80	1.61	3.65	1.34	12100	84
280	5.9	0.88	1.60	0.70	7520	80	1.47	3.60	1.23	12100	84
315	5.7	0.94	1.89	0.64	7520	68	1.23	2.65	0.96	11000	78
360	4.8	0.87	1.79	0.59	7520	67	1.16	2.60	0.90	11100	78
400	4.3	0.67	1.40	0.53	7520	79	1.09	3.44	0.90	12100	82
450	3.8	0.59	1.23	0.46	7510	79	0.98	3.39	0.80	12100	82
500	3.5	0.62	1.31	0.41	7520	66	0.82	2.46	0.62	11200	76
560	3.1	0.55	1.20	0.36	7520	65	0.75	2.43	0.57	11200	76
800	2.2	0.43	1.00	0.27	7520	64	0.55	2.34	0.42	11200	75
900	2.0	0.38	0.89	0.24	7520	64	0.49	2.31	0.37	11200	75

★ Refer to Page 14 for exact ratios.
‡ Refer to Page 6 for Reference Note.

UW – Gear Drive Horsepower & Torque Ratings

1430 High Speed Shaft rpm/Double Reduction

Ratio Code *	Approx Output rpm	SIZE 03					SIZE 04					SIZE 05					SIZE 06				
		Horsepower			Mech Output Torque (lb-in)	Eff %	Horsepower			Mech Output Torque (lb-in)	Eff %	Horsepower			Mech Output Torque (lb-in)	Eff %	Horsepower			Mech Output Torque (lb-in)	Eff %
		Mech Input	Therm Input ‡	Mech Output			Mech Input	Therm Input ‡	Mech Output			Mech Input	Therm Input ‡	Mech Output			Mech Input	Therm Input ‡	Mech Output		
8.0	166	2.30	2.93	1.92	716	83	3.81	4.01	3.24	1210	85	5.89	7.27	5.12	1850	87	10.20	7.10	9.20	3290	89
11.	123	1.86	2.53	1.54	776	83	3.10	3.77	2.62	1320	84	4.85	6.27	4.17	2110	86	8.39	6.51	7.52	3780	89
12.	108	1.70	2.32	1.39	800	82	2.83	3.64	2.37	1360	84	4.58	5.92	3.92	2190	86	7.84	5.98	7.01	3950	89
14.	96	1.56	2.11	1.28	830	82	2.60	3.52	2.17	1410	83	4.25	5.77	3.61	2290	85	7.32	5.31	6.51	4120	88
16.	87	1.49	1.44	1.08	771	73	2.38	2.35	1.79	1270	75	5.23	4.06	4.09	2860	78	8.09	4.05	6.62	4580	80
18.	75	1.30	1.63	1.06	879	81	2.17	3.24	1.79	1490	83	3.68	5.37	3.11	2500	84	6.33	5.42	5.60	4500	88
20.	69	1.24	1.78	1.00	896	81	2.06	3.16	1.70	1520	82	3.40	5.15	2.85	2610	84	5.86	5.34	5.16	4700	88
22.	65	1.22	1.33	0.87	837	71	1.95	2.17	1.44	1380	74	4.11	3.96	3.14	3080	77	6.53	3.85	5.26	5120	80
25.	57	1.12	1.46	0.79	865	71	1.79	2.09	1.31	1430	73	3.84	4.26	2.92	3150	76	6.02	3.99	4.82	5260	79
28.	50	1.03	1.60	0.72	896	70	1.65	2.01	1.20	1480	72	3.50	4.10	2.64	3240	75	5.54	3.94	4.41	5400	79
32.	42	0.86	1.42	0.68	1000	79	1.44	2.55	1.16	1700	81	2.59	4.32	2.14	3020	82	4.37	4.94	3.79	5520	87
36.	39	0.87	1.40	0.60	951	69	1.38	2.02	0.99	1560	71	2.92	3.76	2.16	3370	74	4.62	4.55	3.63	5640	78
40.	36	0.82	1.34	0.57	970	69	1.31	1.94	0.93	1590	71	2.67	3.57	1.96	3470	73	4.20	4.32	3.27	5760	78
45.	31	0.70	1.17	0.55	1080	79	1.16	2.14	0.93	1830	80	2.04	3.54	1.66	3380	81	3.49	4.59	2.99	6150	86
50.	27	0.62	1.05	0.48	1120	78	1.01	1.91	0.80	1850	79	1.93	3.35	1.56	3460	81	3.34	4.53	2.86	6280	86
56.	25	0.64	0.98	0.43	1060	68	1.03	1.54	0.71	1730	69	2.14	3.05	1.54	3700	72	3.35	3.59	2.55	6180	76
63..	22	0.59	0.97	0.39	1090	67	0.94	1.49	0.64	1790	68	1.95	2.81	1.39	3810	71	3.00	3.74	2.27	6380	76
71.	19	0.51	0.93	0.39	1270	77	0.73	1.65	0.56	1830	78	1.42	2.75	1.13	3590	79	2.58	4.14	2.17	6980	84
80.	17	0.47	0.88	0.36	1300	76	0.61	1.55	0.47	1700	77	1.24	2.60	0.98	3530	79	2.42	3.99	2.03	7150	84
90.	16	0.50	0.87	0.33	1230	66	0.79	1.37	0.53	2010	67	1.56	2.33	1.08	4260	69	2.43	3.41	1.79	7130	74
100	14	0.44	0.79	0.29	1270	65	0.71	1.30	0.47	2070	66	1.47	2.26	1.01	4330	69	2.31	3.34	1.70	7220	74
112	13	0.36	0.75	0.27	1360	75	0.40	1.27	0.31	1520	76	0.83	2.26	0.65	3080	78	1.67	3.46	1.38	6620	83
125	11	0.31	0.69	0.23	1300	75	0.31	1.14	0.23	1310	76	0.63	2.07	0.49	2650	78	1.06	3.25	0.87	4690	82
140	10	0.35	0.69	0.22	1360	64	0.56	1.15	0.36	2230	65	1.12	1.95	0.75	4630	67	1.69	2.93	1.21	7520	72
160	9.1	0.32	0.65	0.20	1360	63	0.52	1.09	0.33	2280	64	1.02	1.84	0.68	4740	67	1.56	2.82	1.10	7520	71
212	6.6	0.23	0.54	0.14	1360	62	0.40	0.93	0.25	2390	63	0.83	1.57	0.54	4990	66	1.17	2.43	0.81	7520	69
250	5.8	0.21	0.49	0.13	1360	61	0.31	0.85	0.19	2060	63	0.63	1.42	0.41	4290	65	1.05	2.27	0.72	7520	69

Ratio Code *	Approx Output rpm	SIZE 07					SIZE 08					SIZE 09					SIZE 10				
		Horsepower			Mech Output Torque (lb-in)	Eff %	Horsepower			Mech Output Torque (lb-in)	Eff %	Horsepower			Mech Output Torque (lb-in)	Eff %	Horsepower			Mech Output Torque (lb-in)	Eff %
		Mech Input	Therm Input ‡	Mech Output			Mech Input	Therm Input ‡	Mech Output			Mech Input	Therm Input ‡	Mech Output			Mech Input	Therm Input ‡	Mech Output		
8.0	166	17.30	5.54	15.90	5470	88	27.20	6.16	25.20	8500	85	57.90	14.40	54.30	18800	89	102.00	31.60	95.50	33000	91
11.	123	14.80	7.39	13.60	6490	91	26.40	11.00	24.40	11700	91	48.20	14.40	44.90	21400	90	84.00	41.60	79.00	38100	93
12.	108	13.80	7.66	12.70	6800	91	24.80	12.80	22.90	12200	91	45.00	24.40	41.90	22400	92	80.00	43.60	75.10	39400	93
14.	96	13.10	8.93	12.00	7050	91	23.30	14.70	21.50	12700	92	42.00	27.40	39.20	23500	92	74.20	44.70	69.50	41400	93
16.	87	10.50	4.87	9.23	6340	85	20.40	6.91	18.20	12300	83	35.80	15.70	31.90	23100	86	64.00	20.00	58.00	41900	86
18.	75	11.10	9.13	10.10	7780	91	19.90	13.70	18.30	14000	91	36.10	26.30	33.50	25900	92	63.30	41.30	59.00	45800	93
20.	69	10.30	9.05	9.34	8150	91	18.50	13.60	17.00	14600	91	33.70	25.30	31.10	26900	92	60.40	41.20	56.30	47200	93
22.	65	8.31	6.64	7.27	6910	87	16.50	9.58	14.60	14000	87	29.60	17.30	26.30	26200	87	52.30	26.00	47.30	47700	88
25.	57	7.63	6.86	6.66	7110	87	15.50	11.00	13.70	14600	88	27.60	17.40	24.40	27300	87	49.50	27.20	44.60	49000	89
28.	50	7.11	7.10	6.19	7270	87	14.40	12.00	12.70	15000	87	25.70	17.50	22.70	28500	88	45.00	26.00	40.50	50500	89
32.	42	7.87	9.26	7.07	9470	90	13.80	12.10	12.50	17300	90	25.40	21.30	23.30	31800	91	44.40	36.10	41.00	56700	92
36.	39	5.84	6.94	5.03	7720	86	11.90	11.90	10.40	15900	87	22.10	17.90	19.40	31300	87	36.90	23.20	33.00	53600	89
40.	36	5.30	6.60	4.54	7920	86	10.90	11.70	9.49	16300	87	20.60	17.60	18.00	32600	87	34.90	24.00	31.10	54500	88
45.	31	6.25	8.30	5.53	10600	88	11.30	11.30	10.10	19200	89	20.40	18.20	18.40	35700	91	36.40	33.70	33.30	63200	91
50.	27	5.76	7.75	5.07	11000	88	10.40	10.70	9.30	19900	89	18.60	17.30	16.80	36200	90	34.10	32.30	31.00	65400	91
56.	25	4.24	6.15	3.60	8380	85	8.52	10.70	7.29	17300	86	16.90	16.70	14.50	36400	86	26.00	20.70	22.90	58600	88
63..	22	3.81	5.70	3.21	8590	84	7.57	9.82	6.45	17800	85	15.50	15.90	13.30	38000	86	23.60	19.90	20.70	59900	87
71.	19	4.62	6.54	4.04	12100	87	8.29	8.90	7.30	22100	88	13.90	15.00	12.40	37700	89	26.90	26.90	24.30	73000	90
80.	17	4.23	6.37	3.69	12100	87	7.77	8.55	6.83	22700	88	12.70	13.90	11.40	38100	89	23.90	24.30	21.50	74300	90
90.	16	2.86	4.70	2.37	9100	83	5.89	8.55	4.96	18800	84	12.40	14.10	10.40	42200	84	18.40	18.40	15.90	63000	86
100	14	2.60	4.33	2.14	9300	82	5.35	8.01	4.46	19100	83	11.50	13.50	9.65	43400	84	16.90	17.50	14.50	64100	86
112	13	2.89	5.17	2.49	11300	86	6.31	7.50	5.49	24400	87	9.68	12.20	8.52	39300	88	18.40	20.00	16.40	76600	89
125	11	2.14	4.71	1.83	9210	85	5.62	7.00	4.86	24900	87	8.76	11.30	7.65	39700	87	15.90	19.10	14.00	70700	88
140	10	2.03	3.54	1.65	9900	81	4.11	6.77	3.39	20500	82	9.06	11.70	7.46	47400	82	12.90	14.40	10.90	68700	85
160	9.1	1.90	3.35	1.54	10100	81	3.83	6.61	3.13	20800	82	8.44	11.30	6.91	48500	82	11.60	13.40	9.73	70500	84
212	6.6	1.47	2.56	1.17	10600	80	3.04	5.76	2.46	21900	81	6.70	9.57	5.40	52100	81	9.12	11.30	7.56	74100	83
250	5.8	1.35	2.36	1.07	10800	79	2.72	5.53	2.19	22400	80	6.16	9.22	4.92	53400	80	8.62	11.40	7.12	74900	83

★ Refer to Page 14 for exact ratios.
 ‡ Refer to Page 6 for Reference Note.

UW – Gear Drive Horsepower & Torque Ratings

1430 High Speed Shaft rpm/Triple Reduction

Ratio Code ★	Approx Output rpm	SIZE 03					SIZE 04					SIZE 05				
		Horsepower			Mech Output Torque (lb-in)	Eff %	Horsepower			Mech Output Torque (lb-in)	Eff %	Horsepower			Mech Output Torque (lb-in)	Eff %
		Mech Input	Therm Input ‡	Mech Output			Mech Input	Therm Input ‡	Mech Output			Mech Input	Therm Input ‡	Mech Output		
100	14	0.40	0.57	0.30	1360	74	0.52	1.04	0.39	1800	75	1.01	1.86	0.79	3550	78
118	12	0.35	0.53	0.26	1360	74	0.46	1.00	0.34	1800	75	0.88	1.71	0.68	3530	77
132	11	0.37	0.55	0.23	1310	62	0.58	0.91	0.37	2110	64	1.15	1.63	0.77	4370	67
150	10	0.35	0.54	0.22	1340	62	0.56	0.88	0.36	2170	64	1.10	1.58	0.73	4470	67
160	8.8	0.26	0.45	0.19	1360	73	0.34	0.87	0.25	1780	74	0.66	1.35	0.50	3500	77
180	7.5	0.23	0.46	0.16	1360	73	0.29	0.80	0.21	1770	74	0.56	1.24	0.43	3480	76
200	7.1	0.26	0.46	0.16	1360	61	0.45	0.74	0.28	2440	63	0.87	1.35	0.57	4980	65
225	6.2	0.23	0.43	0.14	1360	61	0.41	0.68	0.26	2550	62	0.79	1.26	0.51	5080	65
265	5.4	0.16	0.36	0.12	1360	72	0.21	0.62	0.15	1750	73	0.40	0.98	0.30	3450	75
280	4.8	0.15	0.33	0.11	1360	72	0.19	0.55	0.14	1740	72	0.36	0.90	0.27	3440	75
315	4.6	0.17	0.37	0.10	1360	59	0.34	0.60	0.21	2790	61	0.61	1.00	0.39	5260	64
360	3.9	0.15	0.34	0.09	1360	59	0.29	0.56	0.18	2760	61	0.53	0.91	0.33	5260	63
400	3.5	0.11	0.25	0.08	1360	71	0.14	0.42	0.10	1730	72	0.26	0.71	0.20	3410	74
450	3.1	0.09	0.23	0.07	1360	71	0.12	0.37	0.09	1720	72	0.23	0.62	0.17	3390	74
500	2.8	0.11	0.25	0.06	1360	58	0.21	0.44	0.12	2720	60	0.39	0.69	0.24	5260	62
560	2.5	0.10	0.23	0.06	1360	58	0.19	0.42	0.11	2700	59	0.35	0.63	0.21	5260	61
800	1.8	0.07	0.18	0.04	1360	57	0.14	0.33	0.08	2670	59	0.26	0.49	0.16	5260	61
900	1.6	0.06	0.16	0.04	1360	57	0.12	0.29	0.07	2650	58	0.23	0.43	0.14	5260	60

Ratio Code ★	Approx Output rpm	SIZE 06					SIZE 07				
		Horsepower			Mech Output Torque (lb-in)	Eff %	Horsepower			Mech Output Torque (lb-in)	Eff %
		Mech Input	Therm Input ‡	Mech Output			Mech Input	Therm Input ‡	Mech Output		
100	14	2.02	2.95	1.67	7520	82	3.34	3.58	2.86	12100	86
118	12	1.79	2.80	1.47	7520	82	2.88	3.16	2.46	12100	85
132	11	1.79	2.33	1.27	7190	71	2.23	3.97	1.79	9720	80
150	10	1.65	2.25	1.16	7470	71	2.02	3.72	1.62	9950	80
160	8.8	1.26	2.32	1.02	7520	81	2.06	2.35	1.74	12100	85
180	7.5	1.16	2.19	0.94	7520	81	1.94	2.23	1.63	12100	84
200	7.1	1.25	2.03	0.86	7520	69	1.57	3.10	1.24	10500	79
225	6.2	1.11	1.93	0.76	7520	68	1.39	2.72	1.10	10800	79
265	5.4	0.82	1.59	0.65	7520	80	1.34	1.58	1.11	12100	83
280	4.8	0.73	1.36	0.58	7520	79	1.23	1.45	1.02	12100	83
315	4.6	0.79	1.61	0.53	7520	67	1.04	2.00	0.81	11300	78
360	3.9	0.73	1.53	0.48	7520	67	0.98	1.89	0.76	11300	78
400	3.5	0.56	1.18	0.44	7500	79	0.91	1.09	0.75	12100	82
450	3.1	0.49	1.05	0.38	7470	78	0.81	0.98	0.66	12100	82
500	2.8	0.52	1.11	0.34	7520	65	0.68	1.34	0.52	11200	76
560	2.5	0.46	1.02	0.30	7520	64	0.62	1.23	0.47	11200	76
800	1.8	0.36	0.85	0.23	7520	64	0.46	0.92	0.35	11200	75
900	1.6	0.32	0.76	0.20	7520	63	0.41	0.83	0.31	11200	75

★ Refer to Page 14 for exact ratios.
 ‡ Refer to Page 6 for Reference Note.

UW – Gear Drive Horsepower & Torque Ratings

1170 High Speed Shaft rpm/Double Reduction

Ratio Code *	Approx Output rpm	SIZE 03					SIZE 04					SIZE 05					SIZE 06				
		Horsepower			Mech Output Torque (lb-in)	Eff %	Horsepower			Mech Output Torque (lb-in)	Eff %	Horsepower			Mech Output Torque (lb-in)	Eff %	Horsepower			Mech Output Torque (lb-in)	Eff %
		Mech Input	Therm Input ‡	Mech Output			Mech Input	Therm Input ‡	Mech Output			Mech Input	Therm Input ‡	Mech Output			Mech Input	Therm Input ‡	Mech Output		
8.0	136	1.95	2.48	1.61	753	83	3.23	3.45	2.72	1270	84	5.18	6.57	4.47	2020	86	8.98	6.38	8.07	3610	89
11.	101	1.58	2.12	1.30	818	82	2.63	3.20	2.19	1380	83	4.25	5.57	3.62	2290	85	7.34	5.72	6.54	4110	89
12.	89	1.44	1.95	1.18	844	82	2.39	3.08	1.98	1420	83	4.01	5.24	3.41	2380	85	6.85	5.25	6.09	4290	88
14.	78	1.32	1.76	1.07	871	81	2.19	2.96	1.81	1470	83	3.71	5.07	3.13	2480	84	6.38	4.66	5.65	4470	88
16.	72	1.27	1.23	0.92	813	72	2.03	1.97	1.51	1340	74	4.45	3.70	3.43	3000	77	7.06	3.65	5.73	4960	79
18.	61	1.10	1.37	0.89	921	81	1.83	2.72	1.50	1560	82	3.20	4.66	2.68	2700	84	5.51	4.67	4.85	4870	88
20.	57	1.05	1.48	0.84	939	80	1.74	2.64	1.42	1590	82	2.96	4.44	2.47	2820	83	5.10	4.58	4.46	5080	87
22.	53	1.04	1.13	0.74	882	71	1.66	1.81	1.21	1450	73	3.49	3.52	2.64	3230	76	5.53	3.40	4.41	5360	79
25.	47	0.95	1.23	0.67	911	70	1.52	1.74	1.09	1490	72	3.25	3.73	2.44	3290	75	5.08	3.48	4.02	5480	79
28.	41	0.87	1.34	0.61	941	70	1.39	1.67	1.00	1540	72	2.95	3.57	2.19	3360	74	4.64	3.42	3.65	5590	78
32.	35	0.73	1.18	0.57	1050	79	1.22	2.12	0.97	1780	80	2.24	3.68	1.83	3240	82	3.78	4.16	3.26	5930	86
36.	32	0.74	1.17	0.50	997	69	1.17	1.67	0.82	1630	70	2.48	3.25	1.81	3520	73	3.89	3.87	3.01	5860	78
40.	30	0.70	1.12	0.48	1020	68	1.12	1.61	0.78	1660	70	2.26	3.07	1.64	3620	72	3.55	3.67	2.73	6010	77
45.	26	0.60	0.97	0.47	1150	78	0.95	1.77	0.75	1850	79	1.65	2.99	1.32	3370	80	3.00	3.83	2.56	6570	85
50.	22	0.54	0.87	0.42	1210	77	0.81	1.58	0.64	1840	78	1.63	2.83	1.31	3610	80	2.87	3.77	2.44	6690	85
56.	21	0.55	0.82	0.36	1110	67	0.87	1.27	0.60	1820	68	1.81	2.61	1.28	3860	71	2.83	3.04	2.13	6450	75
63.	18	0.50	0.81	0.33	1150	66	0.80	1.23	0.54	1880	68	1.66	2.40	1.16	3970	70	2.54	3.14	1.89	6660	75
71.	16	0.44	0.76	0.34	1360	77	0.58	1.36	0.45	1810	77	1.13	2.30	0.89	3560	79	2.20	3.42	1.84	7400	84
80.	14	0.40	0.73	0.30	1360	76	0.49	1.28	0.37	1680	76	0.99	2.17	0.78	3500	78	2.05	3.29	1.71	7520	83
90.	13	0.42	0.72	0.27	1290	65	0.68	1.12	0.45	2100	66	1.32	1.97	0.90	4450	68	2.06	2.84	1.50	7440	73
100	12	0.38	0.65	0.24	1330	64	0.60	1.06	0.39	2170	65	1.24	1.91	0.84	4520	68	1.96	2.79	1.42	7520	72
112	10	0.29	0.62	0.22	1360	75	0.33	1.04	0.25	1530	75	0.68	1.88	0.53	3120	78	1.33	2.84	1.10	6580	82
125	9.0	0.25	0.56	0.19	1320	75	0.25	0.93	0.19	1330	75	0.52	1.72	0.40	2690	77	0.85	2.67	0.69	4660	82
140	8.2	0.28	0.57	0.18	1360	63	0.48	0.94	0.31	2350	64	0.95	1.64	0.63	4840	66	1.37	2.43	0.97	7520	71
160	7.4	0.26	0.54	0.16	1360	62	0.45	0.90	0.28	2430	63	0.87	1.54	0.57	4970	66	1.26	2.34	0.88	7520	70
212	5.4	0.19	0.44	0.12	1360	61	0.33	0.76	0.20	2410	62	0.68	1.30	0.44	5030	65	0.95	2.00	0.65	7520	68
250	4.7	0.17	0.40	0.10	1360	61	0.25	0.69	0.16	2080	62	0.52	1.18	0.33	4330	64	0.85	1.87	0.58	7490	68

Ratio Code *	Approx Output rpm	SIZE 07					SIZE 08					SIZE 09					SIZE 10				
		Horsepower			Mech Output Torque (lb-in)	Eff %	Horsepower			Mech Output Torque (lb-in)	Eff %	Horsepower			Mech Output Torque (lb-in)	Eff %	Horsepower			Mech Output Torque (lb-in)	Eff %
		Mech Input	Therm Input ‡	Mech Output			Mech Input	Therm Input ‡	Mech Output			Mech Input	Therm Input ‡	Mech Output			Mech Input	Therm Input ‡	Mech Output		
8.0	136	13.80	7.36	12.70	5460	91	21.80	10.40	20.10	8490	91	50.90	16.90	47.60	20600	91	83.90	30.60	78.70	34000	92
11.	101	13.00	8.07	11.90	7080	91	21.80	12.80	20.10	12000	91	42.20	15.40	39.30	23400	92	73.60	37.10	69.00	41600	93
12.	89	12.10	8.05	11.10	7400	91	21.70	13.80	20.00	13300	92	39.40	23.10	36.70	24500	92	70.00	38.50	65.50	43000	93
14.	78	11.40	8.91	10.40	7660	91	20.30	15.00	18.70	13800	92	36.70	25.10	34.10	25600	92	64.80	39.00	60.50	45100	93
16.	72	8.92	5.42	7.84	6730	86	17.80	8.37	15.90	13400	86	31.30	15.20	27.80	25200	86	55.90	18.60	50.60	45700	87
18.	61	9.69	8.68	8.79	8430	91	17.30	13.50	15.90	15200	91	31.40	23.50	29.10	28100	92	55.20	35.50	51.30	49800	93
20.	57	8.95	8.47	8.09	8820	90	16.20	13.10	14.70	15800	91	29.40	22.60	27.00	29200	92	52.70	35.30	49.00	51300	92
22.	53	7.04	6.45	6.13	7290	87	14.30	9.74	12.60	15100	88	25.80	15.80	22.90	28500	88	44.60	22.80	40.20	50700	88
25.	47	6.46	6.52	5.61	7490	87	13.20	10.70	11.60	15400	88	24.10	15.80	21.30	29700	87	41.90	23.60	37.60	51600	89
28.	41	6.02	6.63	5.21	7650	87	12.20	11.30	10.70	15800	87	22.50	15.70	19.80	31000	87	38.10	22.40	34.10	53100	89
32.	35	6.82	8.24	6.10	10200	89	12.00	11.20	10.80	18600	89	22.10	18.50	20.10	34300	91	38.60	30.40	35.40	61300	92
36.	32	4.92	6.30	4.21	8080	86	10.00	10.90	8.68	16600	87	19.20	15.60	16.80	33900	87	31.10	19.90	27.60	56100	88
40.	30	4.46	5.95	3.80	8280	85	9.20	10.60	7.92	17000	86	18.00	15.30	15.60	35200	87	29.30	20.40	26.00	56900	88
45.	26	5.38	7.24	4.76	11400	88	9.75	10.10	8.69	20600	89	16.80	15.60	15.20	36700	90	31.50	28.10	28.60	67900	91
50.	22	4.95	6.73	4.35	11800	88	8.99	9.52	7.96	21300	89	15.40	14.90	13.80	37100	89	29.40	26.90	26.60	70200	91
56.	21	3.56	5.44	2.99	8710	84	7.15	9.47	6.07	18000	85	14.60	14.30	12.50	39100	86	21.80	17.50	19.10	60900	87
63.	18	3.19	5.02	2.66	8910	83	6.34	8.67	5.36	18500	85	13.40	13.60	11.40	40700	85	19.80	16.80	17.20	62100	87
71.	16	3.72	5.63	3.23	12100	87	7.08	7.83	6.19	23400	87	11.50	12.70	10.20	38600	88	22.20	22.30	19.90	74900	90
80.	14	3.41	5.46	2.95	12100	86	6.63	7.49	5.78	24000	87	10.50	11.80	9.28	38900	88	19.70	20.10	17.60	76000	89
90.	13	2.41	4.09	1.98	9490	82	4.95	7.45	4.11	19500	83	10.60	11.90	8.85	44800	84	15.40	15.40	13.20	65700	85
100	12	2.19	3.76	1.79	9720	82	4.51	6.96	3.74	20000	83	9.86	11.40	8.18	46000	83	14.30	14.60	12.20	67000	85
112	10	2.31	4.40	1.98	11200	86	5.36	6.50	4.62	25700	86	7.95	10.30	6.95	40100	87	15.00	16.50	13.20	77400	88
125	9.0	1.71	4.01	1.45	9150	85	4.62	6.04	3.97	25400	86	7.19	9.52	6.25	40500	87	12.70	15.80	11.20	70200	88
140	8.2	1.71	3.05	1.37	10300	80	3.45	5.82	2.82	21300	82	7.71	9.76	6.28	49900	81	10.80	12.00	9.10	71500	84
160	7.4	1.59	2.88	1.28	10500	80	3.21	5.66	2.60	21600	81	7.17	9.47	5.82	51000	81	9.69	11.10	8.08	73200	83
212	5.4	1.23	2.20	0.97	11000	79	2.54	4.90	2.03	22600	80	5.67	7.97	4.53	54600	80	7.61	9.35	6.25	76600	82
250	4.7	1.13	2.03	0.89	11200	79	2.27	4.68	1.80	23100	79	5.10	7.66	4.03	54700	79	7.19	9.44	5.89	77500	82

* Refer to Page 14 for exact ratios.
 ‡ Refer to Page 6 for Reference Note.

UW – Gear Drive Horsepower & Torque Ratings

1170 High Speed Shaft rpm/Triple Reduction

Ratio Code ★	Approx Output rpm	SIZE 03					SIZE 04					SIZE 05				
		Horsepower			Mech Output Torque (lb-in)	Eff %	Horsepower			Mech Output Torque (lb-in)	Eff %	Horsepower			Mech Output Torque (lb-in)	Eff %
		Mech Input	Therm Input ‡	Mech Output			Mech Input	Therm Input ‡	Mech Output			Mech Input	Therm Input ‡	Mech Output		
100	11	0.32	0.47	0.24	1360	74	0.42	0.86	0.31	1790	75	0.81	1.56	0.62	3520	77
118	10	0.28	0.44	0.21	1360	74	0.37	0.82	0.27	1780	75	0.71	1.44	0.54	3510	77
132	9.0	0.31	0.46	0.19	1360	62	0.51	0.75	0.32	2280	64	1.00	1.38	0.66	4670	66
150	8.3	0.29	0.44	0.18	1360	62	0.49	0.73	0.31	2330	63	0.95	1.34	0.63	4780	66
160	7.2	0.21	0.37	0.15	1360	73	0.27	0.71	0.20	1760	74	0.53	1.13	0.40	3470	76
180	6.1	0.18	0.38	0.13	1360	73	0.23	0.65	0.17	1760	74	0.45	1.03	0.34	3460	76
200	5.8	0.21	0.38	0.13	1360	60	0.39	0.61	0.24	2630	62	0.73	1.13	0.47	5160	65
225	5.1	0.18	0.35	0.11	1360	60	0.36	0.56	0.22	2750	62	0.66	1.05	0.42	5260	64
265	4.4	0.13	0.30	0.09	1360	72	0.17	0.50	0.12	1740	72	0.32	0.81	0.24	3420	75
280	4.0	0.12	0.27	0.08	1360	72	0.15	0.45	0.11	1730	72	0.29	0.75	0.22	3410	74
315	3.8	0.14	0.30	0.08	1360	59	0.27	0.49	0.16	2750	60	0.50	0.84	0.31	5260	63
360	3.2	0.12	0.27	0.07	1360	59	0.23	0.45	0.14	2730	60	0.43	0.76	0.27	5260	62
400	2.9	0.09	0.21	0.06	1360	71	0.11	0.34	0.08	1720	72	0.21	0.59	0.16	3390	74
450	2.5	0.08	0.19	0.05	1360	71	0.10	0.30	0.07	1710	71	0.19	0.51	0.14	3380	74
500	2.3	0.09	0.20	0.05	1360	58	0.17	0.36	0.10	2690	59	0.31	0.57	0.19	5260	61
560	2.1	0.08	0.19	0.04	1360	57	0.15	0.34	0.09	2680	59	0.28	0.52	0.17	5260	61
800	1.5	0.06	0.15	0.03	1360	57	0.11	0.27	0.06	2640	58	0.21	0.41	0.12	5260	60
900	1.3	0.05	0.13	0.03	1360	56	0.10	0.24	0.05	2630	58	0.18	0.36	0.11	5260	60

Ratio Code ★	Approx Output rpm	SIZE 06					SIZE 07				
		Horsepower			Mech Output Torque (lb-in)	Eff %	Horsepower			Mech Output Torque (lb-in)	Eff %
		Mech Input	Therm Input ‡	Mech Output			Mech Input	Therm Input ‡	Mech Output		
100	11	1.63	2.43	1.33	7520	82	2.69	2.97	2.29	12100	85
118	10	1.44	2.31	1.17	7520	81	2.32	2.61	1.97	12100	85
132	9.0	1.52	1.94	1.07	7520	70	1.87	3.54	1.49	10100	80
150	8.3	1.35	1.87	0.94	7520	69	1.69	3.33	1.34	10300	79
160	7.2	1.01	1.90	0.82	7520	81	1.66	1.93	1.39	12100	84
180	6.1	0.93	1.80	0.75	7520	80	1.56	1.82	1.30	12100	84
200	5.8	1.01	1.68	0.69	7520	68	1.31	2.55	1.03	10900	79
225	5.1	0.90	1.60	0.61	7520	68	1.16	2.23	0.90	11100	78
265	4.4	0.66	1.30	0.52	7520	79	1.08	1.28	0.89	12100	83
280	4.0	0.59	1.12	0.46	7510	79	0.99	1.18	0.81	12100	83
315	3.8	0.64	1.33	0.42	7520	66	0.84	1.64	0.65	11200	77
360	3.2	0.59	1.26	0.39	7520	66	0.79	1.54	0.60	11200	77
400	2.9	0.44	0.97	0.35	7460	78	0.73	0.88	0.60	12100	82
450	2.5	0.39	0.86	0.30	7430	78	0.65	0.79	0.53	12100	81
500	2.3	0.42	0.92	0.27	7520	64	0.54	1.08	0.41	11200	76
560	2.1	0.37	0.84	0.24	7520	64	0.50	1.00	0.38	11200	76
800	1.5	0.29	0.70	0.18	7520	63	0.37	0.74	0.28	11200	75
900	1.3	0.26	0.62	0.16	7520	62	0.33	0.67	0.24	11100	74

★ Refer to Page 14 for exact ratios.
‡ Refer to Page 6 for Reference Note.

UW – Gear Drive Horsepower & Torque Ratings

870 High Speed Shaft rpm/Double Reduction

Ratio Code *	Approx Output rpm	SIZE 03					SIZE 04					SIZE 05					SIZE 06				
		Horsepower			Mech Output Torque (lb-in)	Eff %	Horsepower			Mech Output Torque (lb-in)	Eff %	Horsepower			Mech Output Torque (lb-in)	Eff %	Horsepower			Mech Output Torque (lb-in)	Eff %
		Mech Input	Therm Input ‡	Mech Output			Mech Input	Therm Input ‡	Mech Output			Mech Input	Therm Input ‡	Mech Output			Mech Input	Therm Input ‡	Mech Output		
8.0	101	1.58	1.97	1.30	805	82	2.62	2.79	2.20	1360	84	4.39	5.54	3.76	2250	86	7.60	5.35	6.78	4020	89
11.	75	1.28	1.68	1.04	871	81	2.12	2.56	1.76	1470	83	3.58	4.63	3.03	2540	85	6.18	4.72	5.47	4560	88
12.	66	1.17	1.54	0.94	895	80	1.93	2.46	1.59	1510	82	3.37	4.35	2.83	2620	84	5.76	4.32	5.08	4740	88
14.	58	1.07	1.40	0.86	925	80	1.77	2.36	1.45	1560	82	3.12	4.18	2.61	2740	84	5.36	3.84	4.71	4940	88
16.	53	1.04	1.00	0.74	869	71	1.66	1.56	1.21	1430	73	3.63	3.15	2.75	3180	76	5.72	3.08	4.58	5250	79
18.	45	0.89	1.08	0.71	977	80	1.48	2.15	1.20	1650	81	2.68	3.80	2.22	2960	83	4.61	3.79	4.03	5360	87
20.	42	0.85	1.17	0.67	996	79	1.41	2.09	1.13	1680	80	2.47	3.61	2.04	3090	83	4.26	3.69	3.70	5580	87
22.	39	0.85	0.91	0.59	940	70	1.35	1.43	0.97	1540	72	2.82	2.93	2.09	3390	74	4.42	2.81	3.47	5600	78
25.	35	0.78	0.98	0.54	969	69	1.24	1.37	0.87	1580	70	2.63	3.08	1.93	3460	73	4.07	2.86	3.17	5730	77
28.	31	0.71	1.06	0.49	1000	68	1.14	1.31	0.80	1630	70	2.39	2.93	1.74	3540	73	3.74	2.80	2.90	5880	77
32.	26	0.60	0.92	0.47	1140	78	0.96	1.66	0.76	1850	79	1.85	2.95	1.50	3520	81	3.13	3.30	2.68	6450	85
36.	24	0.60	0.92	0.40	1060	67	0.96	1.31	0.66	1730	69	2.01	2.65	1.44	3720	72	3.15	3.11	2.40	6180	76
40.	22	0.57	0.88	0.38	1080	67	0.91	1.26	0.63	1770	69	1.83	2.49	1.30	3820	71	2.88	2.94	2.17	6350	75
45.	19	0.50	0.76	0.39	1260	77	0.72	1.38	0.56	1830	78	1.24	2.38	0.99	3340	80	2.47	3.01	2.08	7090	84
50.	16	0.45	0.68	0.35	1330	77	0.61	1.23	0.47	1820	78	1.23	2.25	0.97	3570	79	2.36	2.96	1.98	7210	84
56.	15	0.44	0.64	0.29	1180	66	0.71	0.99	0.48	1930	67	1.47	2.10	1.02	4080	70	2.29	2.43	1.70	6800	74
63.	14	0.41	0.64	0.27	1230	65	0.65	0.96	0.43	1990	66	1.34	1.93	0.92	4190	69	2.06	2.49	1.50	7020	73
71.	12	0.34	0.59	0.25	1360	75	0.44	1.05	0.33	1790	76	0.86	1.82	0.67	3530	78	1.70	2.66	1.41	7520	83
80.	11	0.30	0.56	0.23	1360	75	0.37	0.99	0.28	1670	76	0.75	1.71	0.58	3470	78	1.56	2.56	1.29	7520	83
90.	10	0.34	0.56	0.22	1360	64	0.55	0.87	0.36	2230	65	1.07	1.58	0.72	4690	67	1.60	2.24	1.14	7520	71
100	8.6	0.30	0.51	0.19	1360	63	0.49	0.83	0.32	2300	64	1.00	1.52	0.67	4770	67	1.50	2.19	1.07	7520	71
112	7.6	0.22	0.48	0.17	1360	74	0.25	0.81	0.19	1560	75	0.52	1.47	0.40	3170	77	1.01	2.20	0.82	6520	81
125	6.7	0.19	0.44	0.14	1340	74	0.19	0.72	0.14	1350	74	0.40	1.35	0.31	2730	76	0.64	2.07	0.52	4620	81
140	6.1	0.22	0.44	0.13	1360	62	0.40	0.73	0.25	2580	63	0.76	1.29	0.50	5100	65	1.06	1.90	0.73	7520	69
160	5.5	0.20	0.42	0.12	1360	61	0.37	0.69	0.23	2620	63	0.70	1.22	0.45	5200	65	0.97	1.83	0.67	7520	69
212	4.0	0.14	0.34	0.09	1360	60	0.25	0.58	0.16	2440	62	0.52	1.03	0.33	5080	64	0.73	1.56	0.49	7520	67
250	3.5	0.13	0.31	0.08	1360	60	0.19	0.53	0.12	2100	61	0.40	0.93	0.25	4370	63	0.64	1.46	0.43	7370	67

Ratio Code *	Approx Output rpm	SIZE 07					SIZE 08					SIZE 09					SIZE 10				
		Horsepower			Mech Output Torque (lb-in)	Eff %	Horsepower			Mech Output Torque (lb-in)	Eff %	Horsepower			Mech Output Torque (lb-in)	Eff %	Horsepower			Mech Output Torque (lb-in)	Eff %
		Mech Input	Therm Input ‡	Mech Output			Mech Input	Therm Input ‡	Mech Output			Mech Input	Therm Input ‡	Mech Output			Mech Input	Therm Input ‡	Mech Output		
8.0	101	10.40	7.76	9.55	5430	91	16.40	12.00	15.10	8460	92	43.10	16.70	40.20	23100	92	63.30	27.10	59.20	33900	92
11.	75	10.40	7.71	9.52	7500	91	16.40	12.60	15.10	12000	92	35.50	14.60	33.00	26100	92	62.00	31.00	58.00	46400	93
12.	66	10.20	7.54	9.26	8200	91	16.40	13.10	15.10	13300	92	33.10	20.10	30.70	27200	92	59.00	31.80	55.00	47800	93
14.	58	9.59	8.07	8.71	8480	91	16.40	13.80	15.00	14700	91	30.90	21.40	28.60	28400	92	54.60	31.90	50.80	50200	93
16.	53	7.26	5.24	6.35	7220	87	15.00	8.48	13.20	14800	87	26.30	13.50	23.40	28100	87	46.30	16.00	41.80	50000	88
18.	45	8.12	7.61	7.32	9300	90	14.60	12.10	13.30	16800	91	26.40	19.70	24.30	31100	92	46.40	28.70	42.90	55200	92
20.	42	7.48	7.33	6.72	9710	90	13.50	11.70	12.20	17400	90	24.60	18.80	22.60	32300	91	44.20	28.50	40.90	56800	92
22.	39	5.70	5.75	4.92	7760	86	11.50	8.94	10.10	16000	87	21.70	13.50	19.10	31500	87	36.00	18.70	32.20	53900	88
25.	35	5.22	5.71	4.49	7950	86	10.70	9.55	9.31	16400	87	20.30	13.30	17.70	32800	87	33.80	19.20	30.20	54900	88
28.	31	4.86	5.74	4.16	8100	86	9.84	9.86	8.52	16700	87	18.90	13.10	16.40	34200	87	30.70	18.20	27.20	56300	88
32.	26	5.66	6.86	5.00	11100	88	9.97	9.56	8.87	20300	89	17.80	15.10	16.10	36400	90	32.20	24.10	29.30	67200	91
36.	24	3.95	5.34	3.35	8510	85	8.07	9.32	6.91	17500	86	16.10	12.90	13.90	37200	86	25.00	16.00	22.00	59100	88
40.	22	3.57	5.01	3.01	8700	84	7.37	9.00	6.29	17900	85	15.00	12.50	12.90	38600	85	23.50	16.40	20.60	59900	87
45.	19	4.35	5.92	3.81	12100	88	8.04	8.47	7.10	22300	88	13.20	12.60	11.80	37900	90	25.90	22.10	23.40	73500	90
50.	16	3.86	5.49	3.37	12100	87	7.39	7.93	6.48	23000	88	12.10	12.00	10.70	38300	89	23.70	21.10	21.30	74400	90
56.	15	2.84	4.51	2.36	9110	83	5.70	7.88	4.81	18900	84	12.10	11.50	10.20	42500	85	17.40	13.90	15.00	63700	86
63.	14	2.55	4.14	2.11	9340	83	5.07	7.18	4.24	19400	84	11.10	10.90	9.30	44000	84	15.80	13.30	13.60	65200	86
71.	12	2.83	4.55	2.44	12100	86	5.77	6.45	5.01	25100	87	8.94	10.10	7.87	39600	88	17.40	17.40	15.50	77000	89
80.	11	2.59	4.40	2.22	12100	86	5.10	6.15	4.41	24300	87	8.19	9.41	7.20	40000	88	15.40	15.70	13.60	78000	88
90.	10	1.94	3.35	1.57	10000	81	3.98	6.11	3.28	20600	82	8.68	9.47	7.15	48000	82	12.40	12.10	10.50	69300	85
100	8.6	1.76	3.07	1.42	10200	81	3.62	5.68	2.97	21100	82	8.05	9.04	6.60	49200	82	11.40	11.50	9.66	70600	85
112	7.6	1.74	3.53	1.48	11100	85	4.34	5.28	3.72	27400	86	6.19	8.12	5.38	41100	87	11.30	12.90	9.89	76800	88
125	6.7	1.29	3.21	1.09	9090	84	3.55	4.89	3.03	25700	85	5.59	7.52	4.83	41500	86	9.59	12.30	8.36	69700	87
140	6.1	1.36	2.47	1.09	10800	80	2.76	4.71	2.22	22300	81	6.26	7.72	5.04	53100	81	8.64	9.40	7.18	74800	83
160	5.5	1.27	2.33	1.00	10900	79	2.56	4.56	2.05	22600	80	5.81	7.47	4.66	54200	80	7.71	8.70	6.36	76400	83
212	4.0	0.96	1.77	0.75	11300	79	1.99	3.92	1.57	23200	79	4.34	6.26	3.42	54700	79	5.91	7.30	4.81	78100	81
250	3.5	0.87	1.63	0.67	11200	77	1.74	3.73	1.37	23200	79	3.89	6.00	3.04	54700	78	5.53	7.35	4.47	78000	81

* Refer to Page 14 for exact ratios.

‡ Refer to Page 6 for Reference Note.

UW – Gear Drive Horsepower & Torque Ratings

870 High Speed Shaft rpm/Triple Reduction

Ratio Code ★	Approx Output rpm	SIZE 03					SIZE 04					SIZE 05				
		Horsepower			Mech Output Torque (lb-in)	Eff %	Horsepower			Mech Output Torque (lb-in)	Eff %	Horsepower			Mech Output Torque (lb-in)	Eff %
		Mech Input	Therm Input ‡	Mech Output			Mech Input	Therm Input ‡	Mech Output			Mech Input	Therm Input ‡	Mech Output		
100	8.3	0.24	0.36	0.18	1360	73	0.31	0.67	0.23	1770	74	0.61	1.23	0.47	3490	77
118	7.2	0.21	0.34	0.16	1360	73	0.28	0.64	0.20	1770	74	0.53	1.13	0.41	3480	76
132	6.7	0.24	0.36	0.15	1360	61	0.43	0.58	0.27	2500	63	0.82	1.10	0.54	5030	65
150	6.2	0.22	0.35	0.14	1360	61	0.41	0.56	0.25	2560	62	0.78	1.07	0.50	5090	65
160	5.4	0.16	0.28	0.12	1360	73	0.20	0.55	0.15	1750	73	0.40	0.89	0.30	3440	75
180	4.6	0.14	0.29	0.10	1360	72	0.17	0.50	0.13	1740	73	0.34	0.81	0.25	3430	75
200	4.3	0.16	0.29	0.09	1360	60	0.31	0.47	0.19	2770	61	0.57	0.90	0.36	5260	64
225	3.8	0.14	0.27	0.08	1360	59	0.28	0.43	0.17	2760	61	0.50	0.83	0.32	5260	63
265	3.3	0.10	0.23	0.07	1360	71	0.13	0.39	0.09	1730	72	0.24	0.64	0.18	3400	74
280	2.9	0.09	0.21	0.06	1360	71	0.11	0.35	0.08	1720	72	0.22	0.58	0.16	3390	74
315	2.8	0.10	0.24	0.06	1360	59	0.20	0.38	0.12	2720	60	0.38	0.66	0.24	5260	62
360	2.4	0.09	0.21	0.05	1360	58	0.17	0.35	0.10	2700	59	0.33	0.60	0.20	5260	61
400	2.1	0.07	0.16	0.05	1360	71	0.08	0.26	0.06	1710	71	0.16	0.46	0.12	3360	73
450	1.9	0.06	0.14	0.04	1360	70	0.07	0.23	0.05	1700	71	0.14	0.40	0.10	3350	73
500	1.7	0.07	0.16	0.04	1360	57	0.13	0.27	0.07	2660	58	0.24	0.45	0.14	5260	61
560	1.5	0.06	0.14	0.03	1360	57	0.11	0.26	0.07	2650	58	0.22	0.41	0.13	5260	60
800	1.1	0.04	0.11	0.02	1360	56	0.08	0.21	0.05	2610	57	0.16	0.32	0.09	5260	59
900	1.0	0.04	0.10	0.02	1360	56	0.07	0.18	0.04	2600	57	0.14	0.28	0.08	5260	59

Ratio Code ★	Approx Output rpm	SIZE 06					SIZE 07				
		Horsepower			Mech Output Torque (lb-in)	Eff %	Horsepower			Mech Output Torque (lb-in)	Eff %
		Mech Input	Therm Input ‡	Mech Output			Mech Input	Therm Input ‡	Mech Output		
100	8.3	1.24	1.90	1.01	7520	81	2.04	2.33	1.73	12100	85
118	7.2	1.09	1.79	0.89	7520	81	1.76	2.04	1.48	12100	84
132	6.7	1.17	1.53	0.80	7520	69	1.49	2.94	1.18	10600	79
150	6.2	1.03	1.47	0.71	7520	69	1.35	2.63	1.06	10800	78
160	5.4	0.77	1.47	0.62	7520	80	1.26	1.49	1.05	12100	83
180	4.6	0.71	1.40	0.57	7520	80	1.18	1.41	0.98	12100	83
200	4.3	0.78	1.32	0.52	7520	67	1.03	1.98	0.81	11300	78
225	3.8	0.69	1.25	0.46	7520	67	0.89	1.73	0.69	11200	77
265	3.3	0.50	1.01	0.39	7480	79	0.82	0.99	0.67	12100	82
280	2.9	0.44	0.87	0.35	7450	78	0.75	0.91	0.61	12100	82
315	2.8	0.49	1.04	0.32	7520	65	0.64	1.26	0.49	11200	76
360	2.4	0.45	0.98	0.29	7520	65	0.60	1.19	0.46	11200	76
400	2.1	0.33	0.75	0.26	7400	78	0.55	0.68	0.45	12100	81
450	1.9	0.30	0.66	0.23	7380	77	0.50	0.61	0.40	12100	81
500	1.7	0.32	0.71	0.20	7520	63	0.41	0.83	0.31	11200	75
560	1.5	0.29	0.65	0.18	7520	63	0.38	0.76	0.28	11200	75
800	1.1	0.22	0.54	0.14	7520	62	0.28	0.57	0.21	11100	74
900	1.0	0.20	0.48	0.12	7520	62	0.25	0.51	0.18	11100	74

★ Refer to Page 14 for exact ratios.

‡ Refer to Page 6 for Reference Note.

UW – Gear Drive Horsepower & Torque Ratings

500 High Speed Shaft rpm/Double Reduction

Ratio Code *	Approx Output rpm	SIZE 03					SIZE 04					SIZE 05					SIZE 06				
		Horsepower			Mech Output Torque (lb-in)	Eff %	Horsepower			Mech Output Torque (lb-in)	Eff %	Horsepower			Mech Output Torque (lb-in)	Eff %	Horsepower			Mech Output Torque (lb-in)	Eff %
		Mech Input	Therm Input ‡	Mech Output			Mech Input	Therm Input ‡	Mech Output			Mech Input	Therm Input ‡	Mech Output			Mech Input	Therm Input ‡	Mech Output		
8.0	58	1.04	1.22	0.84	908	81	1.71	1.75	1.39	1510	82	3.12	3.64	2.61	2730	84	5.39	3.50	4.74	4920	88
11.	43	0.84	1.03	0.67	978	80	1.39	1.59	1.13	1650	81	2.52	3.00	2.08	3060	83	4.35	3.02	3.79	5520	87
12.	38	0.76	0.94	0.61	1010	80	1.24	1.52	0.99	1650	80	2.36	2.81	1.95	3150	82	4.04	2.76	3.51	5730	87
14.	33	0.70	0.85	0.55	1040	79	1.15	1.45	0.92	1740	80	2.17	2.68	1.78	3280	82	3.75	2.46	3.24	5940	86
16.	31	0.70	0.63	0.48	985	68	1.11	0.96	0.78	1600	70	2.39	2.12	1.74	3530	73	3.72	2.04	2.88	5790	77
18.	26	0.60	0.66	0.47	1130	78	0.92	1.31	0.73	1760	79	1.85	2.41	1.50	3510	81	3.20	2.38	2.74	6390	86
20.	24	0.57	0.71	0.45	1160	78	0.89	1.27	0.71	1830	79	1.69	2.27	1.36	3620	81	2.94	2.31	2.51	6620	85
22.	23	0.56	0.57	0.38	1060	67	0.90	0.88	0.62	1730	69	1.86	1.92	1.33	3780	71	2.91	1.83	2.21	6230	75
25.	20	0.52	0.61	0.34	1090	67	0.82	0.84	0.56	1780	68	1.74	1.99	1.23	3850	71	2.68	1.84	2.02	6380	75
28.	18	0.47	0.65	0.32	1130	67	0.76	0.80	0.51	1840	68	1.58	1.88	1.11	3940	70	2.46	1.79	1.84	6530	74
32.	15	0.42	0.55	0.32	1360	76	0.55	1.00	0.43	1810	77	1.09	1.83	0.87	3560	80	2.11	2.02	1.78	7490	84
36.	14	0.41	0.57	0.27	1220	66	0.64	0.79	0.43	1960	67	1.33	1.69	0.92	4140	69	2.07	1.95	1.52	6870	73
40.	13	0.39	0.54	0.25	1250	65	0.61	0.76	0.41	2010	66	1.22	1.58	0.84	4300	69	1.89	1.84	1.38	7050	73
45.	11	0.31	0.45	0.24	1360	76	0.41	0.83	0.31	1790	77	0.71	1.47	0.55	3270	78	1.52	1.82	1.26	7520	83
50.	9.4	0.27	0.41	0.20	1360	75	0.35	0.74	0.27	1780	76	0.70	1.38	0.55	3510	78	1.43	1.79	1.18	7520	83
56.	8.9	0.30	0.39	0.19	1360	64	0.50	0.60	0.32	2280	65	1.00	1.32	0.67	4710	67	1.50	1.51	1.07	7520	71
63.	7.8	0.27	0.39	0.17	1360	63	0.46	0.58	0.29	2380	64	0.93	1.21	0.62	4900	67	1.31	1.54	0.92	7520	70
71.	6.7	0.20	0.35	0.15	1360	74	0.25	0.63	0.19	1760	75	0.49	1.11	0.38	3470	77	0.99	1.60	0.81	7520	81
80.	6.0	0.18	0.33	0.13	1360	74	0.21	0.59	0.16	1640	74	0.43	1.04	0.33	3410	76	0.91	1.53	0.74	7520	81
90.	5.8	0.20	0.34	0.13	1360	62	0.38	0.52	0.24	2630	63	0.70	0.98	0.45	5190	65	0.95	1.37	0.65	7520	69
100	4.9	0.17	0.31	0.11	1360	61	0.35	0.49	0.22	2770	62	0.65	0.94	0.42	5260	65	0.89	1.34	0.61	7520	69
112	4.4	0.13	0.28	0.09	1360	73	0.15	0.48	0.11	1620	74	0.32	0.89	0.24	3280	76	0.57	1.31	0.46	6420	80
125	3.8	0.11	0.26	0.08	1360	73	0.12	0.43	0.09	1400	73	0.24	0.81	0.18	2830	75	0.37	1.23	0.29	4550	80
140	3.5	0.13	0.26	0.08	1360	60	0.25	0.43	0.15	2740	61	0.46	0.79	0.29	5260	63	0.62	1.15	0.42	7520	67
160	3.2	0.11	0.25	0.07	1360	60	0.21	0.41	0.13	2550	61	0.41	0.74	0.26	5260	63	0.57	1.11	0.38	7520	66
212	2.3	0.08	0.21	0.05	1360	59	0.15	0.35	0.09	2500	60	0.32	0.62	0.20	5210	62	0.43	0.94	0.28	7520	65
250	2.0	0.07	0.19	0.04	1360	59	0.12	0.32	0.07	2160	59	0.24	0.56	0.15	4480	62	0.37	0.88	0.24	7150	65

Ratio Code *	Approx Output rpm	SIZE 07					SIZE 08					SIZE 09					SIZE 10				
		Horsepower			Mech Output Torque (lb-in)	Eff %	Horsepower			Mech Output Torque (lb-in)	Eff %	Horsepower			Mech Output Torque (lb-in)	Eff %	Horsepower			Mech Output Torque (lb-in)	Eff %
		Mech Input	Therm Input ‡	Mech Output			Mech Input	Therm Input ‡	Mech Output			Mech Input	Therm Input ‡	Mech Output			Mech Input	Therm Input ‡	Mech Output		
8.0	58	5.96	6.16	5.39	5370	91	9.39	10.10	8.55	8370	91	30.60	12.60	28.40	28500	92	36.20	18.60	33.60	33700	92
11.	43	5.96	5.69	5.35	7380	90	9.39	9.57	8.50	11800	91	25.10	10.70	23.10	31900	91	36.20	20.10	33.40	46800	92
12.	38	5.96	5.47	5.34	8270	90	9.39	9.65	8.50	13100	90	23.40	13.60	21.40	33200	92	36.20	20.40	33.40	50800	92
14.	33	5.96	5.68	5.33	9070	89	9.39	9.84	8.46	14500	90	21.70	14.20	19.80	34500	91	36.20	20.20	33.30	57500	92
16.	31	4.76	3.94	4.08	8130	85	9.39	6.58	8.17	16000	86	18.70	9.34	16.30	34300	87	30.30	10.70	26.90	56400	87
18.	26	5.63	5.19	4.99	11100	88	9.39	8.47	8.39	18600	89	17.90	12.80	16.20	36400	91	32.50	18.00	29.70	66800	91
20.	24	5.17	4.93	4.59	11600	88	9.39	8.05	8.36	20800	89	16.30	12.10	14.70	36800	90	30.90	17.80	28.20	68500	91
22.	23	3.70	4.01	3.13	8630	85	7.50	6.41	6.41	17800	85	15.30	9.01	13.20	38100	86	23.30	11.90	20.50	60000	88
25.	20	3.37	3.92	2.84	8800	84	6.90	6.66	5.87	18100	85	14.20	8.79	12.20	39500	85	21.80	12.20	19.10	60900	87
28.	18	3.13	3.89	2.62	8940	84	6.34	6.74	5.39	18500	85	13.20	8.59	11.20	40900	85	19.70	11.50	17.20	62100	87
32.	15	3.57	4.43	3.12	12100	87	6.76	6.36	5.94	23800	88	11.00	9.58	9.77	38700	89	20.30	14.80	18.30	73300	90
36.	14	2.53	3.53	2.10	9350	83	5.18	6.21	4.35	19300	84	11.10	8.25	9.36	43900	84	16.00	10.10	13.80	65000	85
40.	13	2.30	3.29	1.90	9590	82	4.74	5.94	3.96	19700	83	10.30	7.98	8.63	45200	83	15.10	10.20	13.00	66000	86
45.	11	2.52	3.76	2.18	12100	86	4.85	5.51	4.22	23200	87	8.10	7.91	7.13	40000	88	15.60	13.40	13.90	76400	89
50.	9.4	2.24	3.47	1.92	12100	86	4.22	5.13	3.66	22700	87	7.38	7.47	6.48	40400	88	13.80	12.80	12.20	74700	88
56.	8.9	1.84	2.91	1.49	10100	81	3.70	5.11	3.04	20900	82	8.18	7.24	6.73	48900	82	11.30	8.58	9.55	70800	84
63.	7.8	1.65	2.66	1.34	10400	81	3.28	4.63	2.68	21500	82	7.44	6.82	6.08	50400	82	10.20	8.18	8.61	72300	84
71.	6.7	1.64	2.85	1.39	12100	85	3.36	4.12	2.87	25200	85	5.44	6.25	4.72	41600	87	10.10	10.50	8.85	77100	88
80.	6.0	1.50	2.74	1.27	12100	85	2.91	3.92	2.48	23900	85	4.97	5.80	4.31	41900	87	8.81	9.45	7.69	77200	87
90.	5.8	1.24	2.13	0.99	11000	80	2.55	3.89	2.05	22600	81	5.75	5.85	4.62	54300	80	7.96	7.37	6.60	75900	83
100	4.9	1.12	1.94	0.89	11200	80	2.31	3.61	1.85	23000	80	5.25	5.57	4.19	54700	80	7.31	6.98	6.03	77100	82
112	4.4	1.00	2.18	0.84	11000	84	2.61	3.32	2.21	28500	85	3.74	4.95	3.20	42800	86	6.46	7.69	5.57	75700	86
125	3.8	0.74	1.99	0.61	8960	83	2.03	3.06	1.70	25300	84	3.37	4.58	2.87	43200	85	5.48	7.34	4.71	68700	86
140	3.5	0.83	1.56	0.64	11200	78	1.67	2.95	1.32	23200	79	3.78	4.72	2.97	54700	79	5.26	5.68	4.28	78000	81
160	3.2	0.76	1.46	0.59	11200	78	1.53	2.85	1.20	23200	79	3.44	4.55	2.69	54700	78	4.59	5.25	3.71	77900	81
212	2.3	0.56	1.11	0.43	11200	77	1.15	2.43	0.90	23100	78	2.54	3.79	1.95	54700	77	3.43	4.38	2.73	77700	80
250	2.0	0.50	1.02	0.38	11200	76	1.01	2.30	0.78	23100	77	2.28	3.63	1.74	54700	76	3.21	4.41	2.54	77600	79

* Refer to Page 14 for exact ratios.

‡ Refer to Page 6 for Reference Note.

UW – Gear Drive Horsepower & Torque Ratings

500 High Speed Shaft rpm/Triple Reduction

Ratio Code ★	Approx Output rpm	SIZE 03					SIZE 04					SIZE 05				
		Horsepower			Mech Output Torque (lb-in)	Eff %	Horsepower			Mech Output Torque (lb-in)	Eff %	Horsepower			Mech Output Torque (lb-in)	Eff %
		Mech Input	Therm Input ‡	Mech Output			Mech Input	Therm Input ‡	Mech Output			Mech Input	Therm Input ‡	Mech Output		
100	4.7	0.14	0.22	0.10	1360	73	0.18	0.40	0.13	1740	73	0.35	0.75	0.26	3430	76
118	4.2	0.12	0.20	0.09	1360	72	0.16	0.38	0.12	1740	73	0.30	0.69	0.23	3420	75
132	3.8	0.14	0.22	0.08	1360	60	0.28	0.35	0.17	2760	61	0.51	0.68	0.32	5260	63
150	3.6	0.13	0.21	0.08	1360	59	0.26	0.34	0.16	2750	61	0.47	0.66	0.30	5260	63
160	3.1	0.09	0.17	0.07	1360	72	0.12	0.33	0.08	1720	72	0.23	0.54	0.17	3390	74
180	2.6	0.08	0.17	0.06	1360	71	0.10	0.30	0.07	1720	72	0.19	0.49	0.14	3380	74
200	2.5	0.09	0.18	0.05	1360	58	0.18	0.28	0.11	2700	60	0.34	0.55	0.21	5260	62
225	2.2	0.08	0.16	0.05	1360	58	0.16	0.25	0.09	2680	59	0.30	0.51	0.18	5260	62
265	1.9	0.06	0.13	0.04	1360	71	0.07	0.23	0.05	1700	71	0.14	0.38	0.10	3350	73
280	1.7	0.05	0.12	0.04	1360	70	0.06	0.21	0.05	1700	71	0.13	0.35	0.09	3350	73
315	1.6	0.06	0.14	0.03	1360	57	0.12	0.22	0.07	2650	59	0.22	0.40	0.14	5260	61
360	1.4	0.05	0.13	0.03	1360	57	0.10	0.21	0.06	2630	58	0.19	0.36	0.12	5260	60
400	1.2	0.04	0.09	0.03	1360	70	0.05	0.16	0.03	1690	71	0.09	0.28	0.07	3320	72
450	1.1	0.03	0.08	0.02	1360	70	0.04	0.14	0.03	1680	70	0.08	0.24	0.06	3320	72
500	1.0	0.04	0.09	0.02	1360	56	0.07	0.16	0.04	2600	57	0.14	0.27	0.08	5260	60
560	0.9	0.03	0.09	0.02	1360	56	0.06	0.15	0.04	2590	57	0.13	0.25	0.07	5240	59
800	0.6	0.02	0.07	0.01	1360	56	0.05	0.12	0.03	2560	56	0.09	0.19	0.05	5180	58
900	0.6	0.02	0.06	0.01	1360	55	0.04	0.11	0.02	2550	56	0.08	0.17	0.05	5160	58

Ratio Code ★	Approx Output rpm	SIZE 06					SIZE 07				
		Horsepower			Mech Output Torque (lb-in)	Eff %	Horsepower			Mech Output Torque (lb-in)	Eff %
		Mech Input	Therm Input ‡	Mech Output			Mech Input	Therm Input ‡	Mech Output		
100	4.7	0.72	1.14	0.58	7520	80	1.18	1.40	0.99	12100	84
118	4.2	0.64	1.07	0.51	7520	80	1.02	1.22	0.85	12100	83
132	3.8	0.69	0.94	0.46	7520	67	0.92	1.78	0.71	11200	77
150	3.6	0.61	0.90	0.40	7520	66	0.81	1.59	0.63	11200	77
160	3.1	0.44	0.88	0.35	7460	79	0.73	0.88	0.60	12100	82
180	2.6	0.41	0.83	0.32	7440	79	0.68	0.83	0.56	12100	82
200	2.5	0.46	0.80	0.30	7520	65	0.60	1.18	0.46	11200	76
225	2.2	0.40	0.76	0.26	7520	65	0.52	1.03	0.39	11200	76
265	1.9	0.28	0.60	0.22	7370	77	0.47	0.58	0.38	12100	81
280	1.7	0.25	0.51	0.20	7350	77	0.43	0.53	0.35	12100	81
315	1.6	0.29	0.62	0.18	7520	63	0.37	0.74	0.28	11200	75
360	1.4	0.27	0.59	0.17	7520	63	0.35	0.70	0.26	11100	75
400	1.2	0.19	0.44	0.15	7310	77	0.32	0.39	0.26	12100	81
450	1.1	0.17	0.39	0.13	7290	77	0.29	0.35	0.23	12100	80
500	1.0	0.19	0.43	0.12	7520	62	0.24	0.49	0.18	11100	74
560	0.9	0.17	0.39	0.10	7520	61	0.22	0.45	0.16	11100	74
800	0.6	0.13	0.32	0.08	7520	61	0.16	0.33	0.12	11100	73
900	0.6	0.11	0.29	0.07	7520	60	0.14	0.30	0.11	11100	73

★ Refer to Page 14 for exact ratios.

‡ Refer to Page 6 for Reference Note.

UW – Gear Drive Horsepower & Torque Ratings

250 High Speed Shaft rpm/Double Reduction

Ratio Code *	Approx Output rpm	SIZE 03					SIZE 04					SIZE 05					SIZE 06				
		Horsepower			Mech Output Torque (lb-in)	Eff %	Horsepower			Mech Output Torque (lb-in)	Eff %	Horsepower			Mech Output Torque (lb-in)	Eff %	Horsepower			Mech Output Torque (lb-in)	Eff %
		Mech Input	Therm Input ‡	Mech Output			Mech Input	Therm Input ‡	Mech Output			Mech Input	Therm Input ‡	Mech Output			Mech Input	Therm Input ‡	Mech Output		
8.0	29	0.63	0.65	0.49	1070	78	0.85	0.95	0.68	1470	80	1.58	2.01	1.29	2700	82	2.95	1.92	2.54	5270	86
11.	22	0.53	0.55	0.41	1200	78	0.70	0.85	0.55	1600	79	1.52	1.64	1.23	3600	81	2.74	1.64	2.34	6810	85
12.	19	0.49	0.50	0.38	1250	77	0.62	0.81	0.48	1610	78	1.38	1.53	1.11	3590	80	2.53	1.50	2.15	7020	85
14.	17	0.45	0.45	0.35	1310	77	0.58	0.77	0.45	1690	78	1.22	1.46	0.97	3570	80	2.33	1.33	1.97	7230	85
16.	15	0.43	0.34	0.28	1160	65	0.67	0.52	0.45	1860	67	1.43	1.19	0.99	4030	70	2.22	1.15	1.64	6600	73
18.	13	0.37	0.35	0.28	1360	77	0.46	0.69	0.36	1710	77	0.96	1.30	0.76	3540	79	1.92	1.28	1.61	7520	84
20.	12	0.34	0.37	0.26	1360	76	0.45	0.67	0.34	1780	77	0.84	1.22	0.67	3530	79	1.71	1.23	1.42	7520	84
22.	11	0.36	0.31	0.23	1290	65	0.56	0.47	0.37	2070	66	1.15	1.06	0.78	4450	68	1.76	1.01	1.28	7220	72
25.	10	0.33	0.33	0.21	1350	64	0.52	0.45	0.34	2170	65	1.08	1.10	0.73	4580	68	1.64	1.02	1.18	7480	71
28.	8.8	0.30	0.35	0.19	1360	64	0.49	0.43	0.32	2270	65	0.99	1.03	0.67	4750	67	1.48	0.98	1.06	7520	71
32.	7.4	0.21	0.29	0.16	1360	75	0.28	0.52	0.21	1770	76	0.55	0.97	0.42	3480	78	1.09	1.07	0.89	7520	82
36.	6.9	0.24	0.30	0.15	1360	63	0.42	0.42	0.27	2460	64	0.84	0.92	0.55	5000	66	1.19	1.06	0.83	7520	70
40.	6.4	0.22	0.29	0.14	1360	62	0.40	0.40	0.26	2530	64	0.76	0.86	0.50	5110	66	1.06	1.00	0.74	7520	70
45.	5.5	0.16	0.24	0.12	1360	74	0.20	0.43	0.15	1750	75	0.36	0.78	0.27	3210	77	0.78	0.96	0.63	7520	81
50.	4.7	0.14	0.21	0.10	1360	73	0.18	0.39	0.13	1740	74	0.35	0.73	0.27	3430	76	0.73	0.94	0.59	7520	81
56.	4.4	0.16	0.21	0.10	1360	61	0.31	0.32	0.20	2780	63	0.58	0.71	0.38	5260	65	0.78	0.81	0.54	7520	68
63.	3.9	0.14	0.20	0.08	1360	61	0.28	0.30	0.17	2760	62	0.52	0.65	0.33	5260	64	0.68	0.82	0.46	7520	68
71.	3.4	0.10	0.18	0.07	1360	73	0.13	0.33	0.09	1730	74	0.24	0.58	0.18	3400	75	0.50	0.83	0.40	7480	80
80.	3.0	0.09	0.17	0.07	1360	72	0.11	0.31	0.08	1610	73	0.21	0.55	0.16	3350	75	0.46	0.80	0.37	7470	80
90.	2.9	0.10	0.18	0.06	1360	60	0.20	0.27	0.13	2720	61	0.36	0.52	0.22	5110	63	0.49	0.73	0.33	7520	66
100	2.5	0.09	0.16	0.05	1360	59	0.18	0.26	0.11	2700	60	0.34	0.50	0.21	5260	63	0.46	0.71	0.31	7520	66
112	2.2	0.07	0.15	0.05	1360	72	0.08	0.25	0.06	1710	73	0.16	0.47	0.12	3370	75	0.29	0.68	0.23	6300	79
125	1.9	0.06	0.13	0.04	1360	71	0.06	0.22	0.04	1410	72	0.12	0.42	0.09	2780	74	0.18	0.64	0.14	4470	78
140	1.8	0.06	0.14	0.04	1360	58	0.13	0.22	0.07	2660	59	0.24	0.42	0.15	5260	62	0.32	0.61	0.21	7520	65
160	1.6	0.06	0.13	0.03	1360	58	0.11	0.21	0.06	2470	59	0.21	0.39	0.13	5260	61	0.30	0.58	0.19	7520	64
212	1.1	0.04	0.11	0.02	1360	57	0.08	0.18	0.05	2610	58	0.16	0.33	0.10	5260	60	0.22	0.50	0.14	7520	63
250	1.0	0.04	0.10	0.02	1360	57	0.06	0.16	0.03	2150	58	0.12	0.30	0.07	4360	60	0.18	0.46	0.11	6910	62

Ratio Code *	Approx Output rpm	SIZE 07					SIZE 08					SIZE 09					SIZE 10				
		Horsepower			Mech Output Torque (lb-in)	Eff %	Horsepower			Mech Output Torque (lb-in)	Eff %	Horsepower			Mech Output Torque (lb-in)	Eff %	Horsepower			Mech Output Torque (lb-in)	Eff %
		Mech Input	Therm Input ‡	Mech Output			Mech Input	Therm Input ‡	Mech Output			Mech Input	Therm Input ‡	Mech Output			Mech Input	Therm Input ‡	Mech Output		
8.0	29	2.98	3.71	2.64	5260	89	4.69	6.22	4.19	8210	89	18.10	7.47	16.40	33000	91	18.10	10.50	16.50	33100	90
11.	22	2.98	3.32	2.63	7240	88	4.69	5.64	4.18	11600	89	14.90	6.18	13.50	37300	90	18.10	10.90	16.40	45900	91
12.	19	2.98	3.16	2.62	8110	88	4.69	5.61	4.15	12800	89	13.60	7.62	12.20	37700	90	18.10	11.10	16.40	49800	90
14.	17	2.98	3.23	2.61	8890	88	4.69	5.64	4.14	14200	88	12.30	7.83	11.00	38200	90	18.10	10.90	16.30	56400	90
16.	15	2.76	2.33	2.30	9160	83	4.69	3.95	3.96	15500	84	12.00	5.35	10.10	42600	84	17.50	6.00	15.20	63600	85
18.	13	2.98	2.91	2.58	11500	87	4.69	4.81	4.13	18300	88	9.84	7.01	8.74	39200	89	17.30	9.65	15.50	69800	90
20.	12	2.76	2.75	2.39	12100	87	4.69	4.54	4.10	20400	88	8.93	6.61	7.90	39600	88	15.80	9.49	14.10	68500	89
22.	11	2.15	2.28	1.77	9750	82	4.36	3.70	3.62	20100	83	9.60	5.04	8.00	46300	83	13.50	6.50	11.60	67800	85
25.	10	1.96	2.22	1.61	9960	82	4.02	3.80	3.32	20500	83	8.86	4.89	7.34	47600	83	12.70	6.61	10.80	68900	85
28.	8.8	1.82	2.18	1.48	10100	81	3.70	3.80	3.05	20900	82	8.16	4.75	6.72	48900	82	11.50	6.21	9.75	70500	84
32.	7.4	1.82	2.41	1.56	12100	86	4.04	3.52	3.48	27900	86	5.95	5.16	5.20	41200	87	10.20	7.80	8.96	71900	88
36.	6.9	1.48	1.96	1.19	10600	80	3.02	3.46	2.47	21900	82	6.78	4.51	5.52	51800	81	9.33	5.41	7.81	73600	83
40.	6.4	1.33	1.82	1.07	10800	80	2.75	3.29	2.24	22300	81	6.25	4.34	5.06	53000	81	8.77	5.47	7.33	74500	83
45.	5.5	1.29	2.02	1.09	12100	84	2.43	3.01	2.06	22700	85	4.36	4.22	3.77	42300	87	7.81	7.03	6.82	75000	87
50.	4.7	1.14	1.86	0.96	12100	84	2.11	2.79	1.79	22200	85	3.96	3.98	3.42	42600	86	6.90	6.68	6.00	73400	87
56.	4.4	1.05	1.59	0.84	11300	80	2.11	2.80	1.69	23200	80	4.72	3.90	3.76	54700	80	6.40	4.56	5.27	78200	82
63.	3.9	0.92	1.45	0.72	11200	79	1.82	2.53	1.45	23200	80	4.17	3.66	3.30	54700	79	5.68	4.34	4.65	78100	82
71	3.4	0.83	1.52	0.70	12100	83	1.68	2.23	1.41	24700	84	2.90	3.30	2.47	43600	85	5.04	5.46	4.34	75700	86
80..	3.0	0.76	1.46	0.64	12100	83	1.46	2.11	1.22	23500	83	2.65	3.06	2.26	43900	85	4.40	4.92	3.78	75900	86
90.	2.9	0.65	1.15	0.50	11200	78	1.34	2.11	1.05	23100	78	2.99	3.12	2.33	54700	78	4.19	3.89	3.38	77800	81
100	2.5	0.58	1.05	0.45	11200	77	1.19	1.95	0.93	23100	78	2.70	2.96	2.10	54700	78	3.78	3.67	3.04	77700	80
112	2.2	0.50	1.16	0.41	10800	82	1.31	1.78	1.09	28000	83	1.98	2.60	1.67	44600	84	3.23	3.99	2.74	74500	85
125	1.9	0.37	1.05	0.30	8820	82	1.01	1.63	0.84	24900	83	1.75	2.40	1.47	44100	84	2.74	3.81	2.32	67600	85
140	1.8	0.42	0.84	0.32	11200	76	0.85	1.58	0.66	23000	77	1.94	2.49	1.48	54700	77	2.68	2.98	2.13	77500	79
160	1.6	0.39	0.78	0.29	11200	76	0.78	1.53	0.60	23000	77	1.77	2.40	1.34	54700	76	2.34	2.75	1.84	77400	79
212	1.1	0.28	0.59	0.21	11100	75	0.59	1.29	0.45	23000	76	1.30	1.99	0.98	54700	75	1.75	2.29	1.36	77200	78
250	1.0	0.26	0.54	0.19	11100	75	0.51	1.22	0.39	22900	75	1.17	1.90	0.87	54700	74	1.63	2.30	1.26	77100	77

* Refer to Page 14 for exact ratios.
 ‡ Refer to Page 6 for Reference Note.

UW – Gear Drive Horsepower & Torque Ratings

250 High Speed Shaft rpm/Triple Reduction

Ratio Code ★	Approx Output rpm	SIZE 03					SIZE 04					SIZE 05				
		Horsepower			Mech Output Torque (lb-in)	Eff %	Horsepower			Mech Output Torque (lb-in)	Eff %	Horsepower			Mech Output Torque (lb-in)	Eff %
		Mech Input	Therm Input ‡	Mech Output			Mech Input	Therm Input ‡	Mech Output			Mech Input	Therm Input ‡	Mech Output		
100	2.4	0.07	0.11	0.05	1360	71	0.09	0.21	0.06	1710	72	0.17	0.40	0.13	3370	74
118	2.1	0.06	0.10	0.04	1360	71	0.08	0.20	0.06	1710	72	0.15	0.36	0.11	3360	74
132	1.9	0.07	0.11	0.04	1360	58	0.14	0.18	0.08	2670	59	0.26	0.36	0.16	5260	61
150	1.8	0.07	0.11	0.04	1360	58	0.13	0.17	0.08	2660	59	0.24	0.35	0.15	5260	61
160	1.5	0.05	0.09	0.03	1360	71	0.06	0.17	0.04	1690	71	0.11	0.28	0.08	3340	73
180	1.3	0.04	0.09	0.03	1360	70	0.05	0.15	0.04	1690	71	0.10	0.26	0.07	3330	73
200	1.2	0.05	0.09	0.03	1360	57	0.09	0.14	0.05	2620	58	0.17	0.29	0.10	5260	60
225	1.1	0.04	0.08	0.02	1360	57	0.08	0.13	0.05	2610	58	0.15	0.27	0.09	5260	60
265	0.9	0.03	0.07	0.02	1360	70	0.04	0.12	0.02	1680	70	0.07	0.20	0.05	3310	72
280	0.8	0.03	0.06	0.02	1360	69	0.03	0.11	0.02	1670	70	0.06	0.18	0.04	3300	72
315	0.8	0.03	0.07	0.02	1360	56	0.06	0.12	0.03	2580	57	0.11	0.21	0.07	5220	59
360	0.7	0.03	0.07	0.01	1360	56	0.05	0.11	0.03	2570	57	0.10	0.19	0.06	5190	59
400	0.6	0.02	0.05	0.01	1360	69	0.02	0.08	0.02	1660	70	0.05	0.14	0.03	3280	72
450	0.5	0.02	0.04	0.01	1360	69	0.02	0.07	0.01	1660	69	0.04	0.13	0.03	3280	71
500	0.5	0.02	0.05	0.01	1360	55	0.04	0.08	0.02	2540	56	0.07	0.14	0.04	5140	58
560	0.4	0.02	0.04	0.01	1360	55	0.03	0.08	0.02	2530	56	0.06	0.13	0.04	5130	58
800	0.3	0.01	0.03	0.01	1360	55	0.02	0.06	0.01	2510	55	0.05	0.10	0.03	5080	57
900	0.3	0.01	0.03	0.01	1360	54	0.02	0.05	0.01	2500	55	0.04	0.09	0.02	5060	57

Ratio Code ★	Approx Output rpm	SIZE 06					SIZE 07				
		Horsepower			Mech Output Torque (lb-in)	Eff %	Horsepower			Mech Output Torque (lb-in)	Eff %
		Mech Input	Therm Input ‡	Mech Output			Mech Input	Therm Input ‡	Mech Output		
100	2.4	0.36	0.59	0.28	7420	79	0.60	0.73	0.49	12100	82
118	2.1	0.32	0.56	0.25	7390	78	0.52	0.63	0.42	12100	82
132	1.9	0.36	0.50	0.23	7520	64	0.47	0.94	0.36	11200	76
150	1.8	0.32	0.48	0.20	7520	64	0.41	0.83	0.31	11200	76
160	1.5	0.22	0.45	0.17	7330	78	0.37	0.45	0.30	12100	81
180	1.3	0.20	0.43	0.16	7320	78	0.35	0.43	0.28	12100	81
200	1.2	0.24	0.42	0.15	7520	63	0.30	0.62	0.23	11100	75
225	1.1	0.21	0.40	0.13	7520	63	0.26	0.53	0.20	11100	75
265	0.9	0.14	0.31	0.11	7260	76	0.24	0.30	0.19	12100	80
280	0.8	0.13	0.27	0.10	7250	76	0.22	0.27	0.18	12100	80
315	0.8	0.15	0.33	0.09	7520	61	0.19	0.38	0.14	11100	74
360	0.7	0.14	0.31	0.08	7520	61	0.18	0.36	0.13	11100	74
400	0.6	0.10	0.23	0.07	7210	76	0.16	0.20	0.13	12100	79
450	0.5	0.08	0.20	0.06	7190	75	0.15	0.18	0.12	12100	79
500	0.5	0.10	0.22	0.06	7520	60	0.12	0.25	0.09	11100	73
560	0.4	0.09	0.20	0.05	7520	60	0.11	0.23	0.08	11100	73
800	0.3	0.07	0.17	0.04	7520	59	0.08	0.17	0.06	11000	72
900	0.3	0.06	0.15	0.03	7520	59	0.07	0.15	0.05	11000	71

★ Refer to Page 14 for exact ratios.
‡ Refer to Page 6 for Reference Note.

UW – Gear Drive Part Numbers

Hollow Low Speed Shaft Basic Gear Drive – Double Reduction

Drive Size	Ratio Code	Exact Ratio	Drive Designation	Drive Part No.	Drive Size	Ratio Code	Exact Ratio	Drive Designation	Drive Part No.	Drive Size	Ratio Code	Exact Ratio	Drive Designation	Drive Part No.
03	8.0	8.591	03UWAQ2A8.0N	4760285	04	28.	28.48	04UWAQ2A28.N	4760413	05	80.	82.67	05UWAQ2A80.N	4760538
03	11.	11.61	03UWAQ2A11.N	4760289	04	32.	33.71	04UWAQ2A32.N	4760416	05	90.	90.67	05UWAQ2A90.N	4760541
03	12.	13.20	03UWAQ2A12.N	4760293	04	36.	36.43	04UWAQ2A36.N	4760420	05	100	98.57	05UWAQ2A100N	4760544
03	14.	14.95	03UWAQ2A14.N	4760297	04	40.	39.26	04UWAQ2A40.N	4760424	05	112	109.1	05UWAQ2A112N	4760546
03	16.	16.36	03UWAQ2A16.N	4760301	04	45.	45.50	04UWAQ2A45.N	4760427	05	125	124.0	05UWAQ2A125N	4760549
03	18.	19.13	03UWAQ2A18.N	4760305	04	50.	53.31	04UWAQ2A50.N	4760430	05	140	142.0	05UWAQ2A140N	4760552
03	20.	20.61	03UWAQ2A20.N	4760309	04	56.	56.19	04UWAQ2A56.N	4760433	05	160	160.0	05UWAQ2A160N	4760555
03	22.	22.11	03UWAQ2A22.N	4760313	04	63.	64.21	04UWAQ2A63.N	4760436	05	212	211.1	05UWAQ2A212N	4760558
03	25.	25.14	03UWAQ2A25.N	4760317	04	71.	74.55	04UWAQ2A71.N	4760439	05	250	240.0	05UWAQ2A250N	4760561
03	28.	28.48	03UWAQ2A28.N	4760321	04	80.	82.83	04UWAQ2A80.N	4760442	06	8.0	8.232	06UWAQ2A8.0N	4760564
03	32.	33.71	03UWAQ2A32.N	4760324	04	90.	86.67	04UWAQ2A90.N	4760445	06	11.	11.57	06UWAQ2A11.N	4760567
03	36.	36.43	03UWAQ2A36.N	4760328	04	100	101.5	04UWAQ2A100N	4760448	06	12.	12.97	06UWAQ2A12.N	4760570
03	40.	39.26	03UWAQ2A40.N	4760332	04	112	114.3	04UWAQ2A112N	4760451	06	14.	14.56	06UWAQ2A14.N	4760573
03	45.	45.50	03UWAQ2A45.N	4760335	04	125	129.9	04UWAQ2A125N	4760454	06	16.	15.93	06UWAQ2A16.N	4760576
03	50.	53.31	03UWAQ2A50.N	4760337	04	140	142.0	04UWAQ2A140N	4760457	06	18.	18.49	06UWAQ2A18.N	4760579
03	56.	56.19	03UWAQ2A56.N	4760340	04	160	157.8	04UWAQ2A160N	4760460	06	20.	20.96	06UWAQ2A20.N	4760582
03	63.	64.21	03UWAQ2A63.N	4760343	04	212	217.8	04UWAQ2A212N	4760463	06	22.	22.40	06UWAQ2A22.N	4760585
03	71.	74.55	03UWAQ2A71.N	4760346	04	250	247.5	04UWAQ2A250N	4760466	06	25.	25.11	06UWAQ2A25.N	4760588
03	80.	82.83	03UWAQ2A80.N	4760349	05	8.0	8.312	05UWAQ2A8.0N	4760470	06	28.	28.18	06UWAQ2A28.N	4760591
03	90.	86.67	03UWAQ2A90.N	4760352	05	11.	11.66	05UWAQ2A11.N	4760474	06	32.	33.48	06UWAQ2A32.N	4760595
03	100	101.5	03UWAQ2A100N	4760355	05	12.	12.85	05UWAQ2A12.N	4760478	06	36.	35.79	06UWAQ2A36.N	4760598
03	112	114.3	03UWAQ2A112N	4760358	05	14.	14.59	05UWAQ2A14.N	4760482	06	40.	40.57	06UWAQ2A40.N	4760601
03	125	129.9	03UWAQ2A125N	4760361	05	16.	16.09	05UWAQ2A16.N	4760486	06	45.	47.32	06UWAQ2A45.N	4760605
03	140	142.0	03UWAQ2A140N	4760364	05	18.	18.53	05UWAQ2A18.N	4760490	06	50.	50.52	06UWAQ2A50.N	4760609
03	160	157.8	03UWAQ2A160N	4760367	05	20.	21.05	05UWAQ2A20.N	4760494	06	56.	55.71	06UWAQ2A56.N	4760613
03	212	217.8	03UWAQ2A212N	4760370	05	22.	22.56	05UWAQ2A22.N	4760498	06	63.	64.80	06UWAQ2A63.N	4760617
03	250	247.5	03UWAQ2A250N	4760373	05	25.	24.86	05UWAQ2A25.N	4760502	06	71.	73.92	06UWAQ2A71.N	4760621
04	8.0	8.591	04UWAQ2A8.0N	4760377	05	28.	28.24	05UWAQ2A28.N	4760506	06	80.	80.94	06UWAQ2A80.N	4760625
04	11.	11.61	04UWAQ2A11.N	4760381	05	32.	32.55	05UWAQ2A32.N	4760510	06	90.	91.58	06UWAQ2A90.N	4760629
04	12.	13.20	04UWAQ2A12.N	4760385	05	36.	35.86	05UWAQ2A36.N	4760514	06	100	97.78	06UWAQ2A100N	4760633
04	14.	14.95	04UWAQ2A14.N	4760389	05	40.	40.74	05UWAQ2A40.N	4760518	06	112	110.6	06UWAQ2A112N	4760637
04	16.	16.36	04UWAQ2A16.N	4760393	05	45.	46.84	05UWAQ2A45.N	4760521	06	125	124.0	06UWAQ2A125N	4760641
04	18.	19.13	04UWAQ2A18.N	4760397	05	50.	50.93	05UWAQ2A50.N	4760524	06	140	143.1	06UWAQ2A140N	4760645
04	20.	20.61	04UWAQ2A20.N	4760401	05	56.	55.45	05UWAQ2A56.N	4760528	06	160	156.7	06UWAQ2A160N	4760649
04	22.	22.11	04UWAQ2A22.N	4760405	05	63.	63.00	05UWAQ2A63.N	4760532	06	212	214.0	06UWAQ2A212N	4760653
04	25.	25.14	04UWAQ2A25.N	4760409	05	71.	73.37	05UWAQ2A71.N	4760535	06	250	240.0	06UWAQ2A250N	4760657

Continued on next page

UW – Gear Drive Part Numbers

Hollow Low Speed Shaft Basic Gear Drive – Double Reduction (Continued)

Drive Size	Ratio Code	Exact Ratio	Drive Designation	Drive Part No.	Drive Size	Ratio Code	Exact Ratio	Drive Designation	Drive Part No.	Drive Size	Ratio Code	Exact Ratio	Drive Designation	Drive Part No.
07	8.0	7.901	07UWBQ2A8.0N	4760661	08	28.	27.22	08UWBQ2A28.N	4760818	09	80.	77.18	09UWBQ2A80.N	4760994
07	11.	10.94	07UWBQ2A11.N	4760665	08	32.	31.78	08UWBQ2A32.N	4760822	09	90.	93.18	09UWBQ2A90.N	4761000
07	12.	12.29	07UWBQ2A12.N	4761816	08	36.	35.20	08UWBQ2A36.N	4760826	09	100	103.5	09UWBQ2A100N	4761006
07	14.	13.52	07UWBQ2A14.N	4760672	08	40.	39.51	08UWBQ2A40.N	4760830	09	112	106.2	09UWBQ2A112N	4761012
07	16.	15.80	07UWBQ2A16.N	4760676	08	45.	43.64	08UWBQ2A45.N	4760836	09	125	119.4	09UWBQ2A125N	4761018
07	18.	17.66	07UWBQ2A18.N	4760680	08	50.	49.26	08UWBQ2A50.N	4760842	09	140	146.2	09UWBQ2A140N	4761024
07	20.	20.07	07UWBQ2A20.N	4760684	08	56.	54.60	08UWBQ2A56.N	4760846	09	160	161.4	09UWBQ2A160N	4761030
07	22.	21.89	07UWBQ2A22.N	4760688	08	63.	63.56	08UWBQ2A63.N	4760850	09	212	222.1	09UWBQ2A212N	4761036
07	25.	24.59	07UWBQ2A25.N	4760692	08	71.	69.64	08UWBQ2A71.N	4760856	09	250	249.7	09UWBQ2A250N	4761042
07	28.	27.03	07UWBQ2A28.N	4761817	08	80.	76.50	08UWBQ2A80.N	4760862	10	8.0	7.951	10UWBQ2A8.0N	4763422
07	32.	30.81	07UWBQ2A32.N	4760700	08	90.	87.29	08UWBQ2A90.N	4760868	10	11.	11.11	10UWBQ2A11.N	4763426
07	36.	35.31	07UWBQ2A36.N	4760704	08	100	98.53	08UWBQ2A100N	4760874	10	12.	12.08	10UWBQ2A12.N	4763430
07	40.	40.15	07UWBQ2A40.N	4760708	08	112	102.4	08UWBQ2A112N	4760880	10	14.	13.72	10UWBQ2A14.N	4763434
07	45.	44.13	07UWBQ2A45.N	4760713	08	125	117.9	08UWBQ2A125N	4760886	10	16.	16.63	10UWBQ2A16.N	4763438
07	50.	49.90	07UWBQ2A50.N	4760718	08	140	139.3	08UWBQ2A140N	4760892	10	18.	17.87	10UWBQ2A18.N	4763442
07	56.	53.63	07UWBQ2A56.N	4760723	08	160	153.0	08UWBQ2A160N	4760898	10	20.	19.29	10UWBQ2A20.N	4763446
07	63.	61.62	07UWBQ2A63.N	4760728	08	212	204.8	08UWBQ2A212N	4760904	10	22.	23.23	10UWBQ2A22.N	4763450
07	71.	69.00	07UWBQ2A71.N	4760733	08	250	235.8	08UWBQ2A250N	4760910	10	25.	25.27	10UWBQ2A25.N	4763454
07	80.	75.56	07UWBQ2A80.N	4760738	09	8.0	7.973	09UWBQ2A8.0N	4760914	10	28.	28.70	10UWBQ2A28.N	4763458
07	90.	88.26	07UWBQ2A90.N	4760743	09	11.	10.98	09UWBQ2A11.N	4760918	10	32.	31.85	10UWBQ2A32.N	4763462
07	100	99.79	07UWBQ2A100N	4760748	09	12.	12.30	09UWBQ2A12.N	4760922	10	36.	37.38	10UWBQ2A36.N	4763466
07	112	104.3	07UWBQ2A112N	4760753	09	14.	13.81	09UWBQ2A14.N	4760926	10	40.	40.36	10UWBQ2A40.N	4763470
07	125	115.9	07UWBQ2A125N	4760758	09	16.	16.68	09UWBQ2A16.N	4760930	10	45.	46.65	10UWBQ2A45.N	4763476
07	140	138.0	07UWBQ2A140N	4760763	09	18.	17.79	09UWBQ2A18.N	4760934	10	50.	48.51	10UWBQ2A50.N	4763482
07	160	151.1	07UWBQ2A160N	4760768	09	20.	19.88	09UWBQ2A20.N	4760938	10	56.	58.85	10UWBQ2A56.N	4763486
07	212	208.6	07UWBQ2A212N	4760773	09	22.	22.96	09UWBQ2A22.N	4760942	10	63.	66.63	10UWBQ2A63.N	4763490
07	250	231.8	07UWBQ2A250N	4760778	09	25.	25.73	09UWBQ2A25.N	4760946	10	71.	69.18	10UWBQ2A71.N	4763496
08	8.0	7.770	08UWBQ2A8.0N	4760782	09	28.	28.89	09UWBQ2A28.N	4760950	10	80.	79.71	10UWBQ2A80.N	4763502
08	11.	11.01	08UWBQ2A11.N	4760786	09	32.	31.43	09UWBQ2A32.N	4760954	10	90.	91.32	10UWBQ2A90.N	4763508
08	12.	12.24	08UWBQ2A12.N	4760790	09	36.	37.22	09UWBQ2A36.N	4760958	10	100	101.5	10UWBQ2A100N	4763514
08	14.	13.61	08UWBQ2A14.N	4760794	09	40.	41.59	09UWBQ2A40.N	4760962	10	112	107.8	10UWBQ2A112N	4763520
08	16.	15.54	08UWBQ2A16.N	4760798	09	45.	44.55	09UWBQ2A45.N	4760968	10	125	115.8	10UWBQ2A125N	4763526
08	18.	17.60	08UWBQ2A18.N	4760802	09	50.	49.49	09UWBQ2A50.N	4760974	10	140	144.7	10UWBQ2A140N	4763532
08	20.	19.76	08UWBQ2A20.N	4760806	09	56.	57.66	09UWBQ2A56.N	4760978	10	160	166.7	10UWBQ2A160N	4763538
08	22.	22.03	08UWBQ2A22.N	4760810	09	63.	65.74	09UWBQ2A63.N	4760982	10	212	225.5	10UWBQ2A212N	4763544
08	25.	24.47	08UWBQ2A25.N	4760814	09	71.	69.91	09UWBQ2A71.N	4760988	10	250	242.3	10UWBQ2A250N	4763550

UW – Gear Drive Part Numbers

Hollow Low Speed Shaft Basic Gear Drive – Triple Reduction

Drive Size	Ratio Code	Exact Ratio	Drive Designation	Drive Part No.	Drive Size	Ratio Code	Exact Ratio	Drive Designation	Drive Part No.	Drive Size	Ratio Code	Exact Ratio	Drive Designation	Drive Part No.
03	100	105.4	03UWAQ3A100N	4761432	04	400	408.3	04UWAQ3A400N	4761526	06	200	201.0	06UWAQ3A200N	4761623
03	118	120.4	03UWAQ3A118N	4761435	04	450	464.1	04UWAQ3A450N	4761529	06	225	228.4	06UWAQ3A225N	4761627
03	132	130.1	03UWAQ3A132N	4761439	04	500	507.1	04UWAQ3A500N	4761532	06	265	266.0	06UWAQ3A265N	4761630
03	150	140.2	03UWAQ3A150N	4761443	04	560	563.5	04UWAQ3A560N	4761535	06	280	299.7	06UWAQ3A280N	4761633
03	160	162.5	03UWAQ3A160N	4761446	04	800	777.8	04UWAQ3A800N	4761538	06	315	328.7	06UWAQ3A315N	4761636
03	180	190.4	03UWAQ3A180N	4761449	04	900	883.9	04UWAQ3A900N	4761541	06	360	357.3	06UWAQ3A360N	4761639
03	200	200.7	03UWAQ3A200N	4761452	05	100	103.9	05UWAQ3A100N	4761544	06	400	395.4	06UWAQ3A400N	4761642
03	225	229.3	03UWAQ3A225N	4761455	05	118	118.7	05UWAQ3A118N	4761547	06	450	449.5	06UWAQ3A450N	4761645
03	265	266.3	03UWAQ3A265N	4761458	05	132	130.4	05UWAQ3A132N	4761551	06	500	514.8	06UWAQ3A500N	4761648
03	280	295.8	03UWAQ3A280N	4761461	05	150	140.5	05UWAQ3A150N	4761555	06	560	580.0	06UWAQ3A560N	4761651
03	315	309.5	03UWAQ3A315N	4761464	05	160	160.3	05UWAQ3A160N	4761558	06	800	765.3	06UWAQ3A800N	4761654
03	360	362.6	03UWAQ3A360N	4761467	05	180	187.8	05UWAQ3A180N	4761561	06	900	870.0	06UWAQ3A900N	4761657
03	400	408.3	03UWAQ3A400N	4761470	05	200	201.1	05UWAQ3A200N	4761564	07	100	97.33	07UWBQ3A100N	4761661
03	450	464.1	03UWAQ3A450N	4761473	05	225	229.8	05UWAQ3A225N	4761567	07	118	113.2	07UWBQ3A118N	4761665
03	500	507.1	03UWAQ3A500N	4761476	05	265	262.6	05UWAQ3A265N	4761570	07	132	125.0	07UWBQ3A132N	4761668
03	560	563.5	03UWAQ3A560N	4761479	05	280	291.8	05UWAQ3A280N	4761573	07	150	141.7	07UWBQ3A150N	4761671
03	800	777.8	03UWAQ3A800N	4761482	05	315	310.2	05UWAQ3A315N	4761576	07	160	160.0	06UWBQ3A160N	4761675
03	900	883.9	03UWAQ3A900N	4761485	05	360	363.4	05UWAQ3A360N	4761579	07	180	170.8	07UWBQ3A180N	4761679
04	100	105.4	04UWAQ3A100N	4761488	05	400	402.7	05UWAQ3A400N	4761582	07	200	194.7	07UWBQ3A200N	4761683
04	118	120.4	04UWAQ3A118N	4761491	05	450	457.7	05UWAQ3A450N	4761585	07	225	226.4	07UWBQ3A225N	4761687
04	132	130.1	04UWAQ3A132N	4761495	05	500	508.2	05UWAQ3A500N	4761588	07	265	249.9	07UWBQ3A265N	4761691
04	150	140.2	04UWAQ3A150N	4761499	05	560	564.7	05UWAQ3A560N	4761591	07	280	273.7	07UWBQ3A280N	4761695
04	160	162.5	04UWAQ3A160N	4761502	05	800	779.4	05UWAQ3A800N	4761594	07	315	320.0	07UWBQ3A315N	4761699
04	180	190.4	04UWAQ3A180N	4761505	05	900	885.8	05UWAQ3A900N	4761597	07	360	341.6	07UWBQ3A360N	4761703
04	200	200.7	04UWAQ3A200N	4761508	06	100	103.9	06UWAQ3A100N	4761601	07	400	373.8	07UWBQ3A400N	4761707
04	225	229.3	04UWAQ3A225N	4761511	06	118	118.0	06UWAQ3A118N	4761605	07	450	419.3	07UWBQ3A450N	4761711
04	265	266.3	04UWAQ3A265N	4761514	06	132	130.0	06UWAQ3A132N	4761609	07	500	499.9	07UWBQ3A500N	4761715
04	280	295.8	04UWAQ3A280N	4761517	06	150	147.7	06UWAQ3A150N	4761613	07	560	547.4	07UWBQ2A560N	4761719
04	315	309.5	04UWAQ3A315N	4761520	06	160	169.8	06UWAQ3A160N	4761616	07	800	747.7	07UWBQ2A800N	4761723
04	360	362.6	04UWAQ3A360N	4761523	06	180	184.6	06UWAQ3A180N	4761619	07	900	838.5	07UWBQ2A900N	4761727

UW – Gear Drive Part Numbers

Hollow Low Speed Shaft With Drywell – Flange Mounted – Double Reduction

Drive Size	Ratio Code	Exact Ratio	Drive Designation	Drive Part No.	Drive Size	Ratio Code	Exact Ratio	Drive Designation	Drive Part No.
07	8.0	7.901	07UWXQ2A8.0N	4761046	08	8.0	7.770	08UWXQ2A8.0N	4761169
07	11.	10.94	07UWXQ2A11.N	4761050	08	11.	11.01	08UWXQ2A11.N	4761173
07	12.	12.29	07UWXQ2A12.N	4761054	08	12.	12.24	08UWXQ2A12.N	4761177
07	14.	13.52	07UWXQ2A14.N	4761058	08	14.	13.61	08UWXQ2A14.N	4761181
07	16.	15.80	07UWXQ2A16.N	4761062	08	16.	15.54	08UWXQ2A16.N	4761185
07	18.	17.66	07UWXQ2A18.N	4761066	08	18.	17.60	08UWXQ2A18.N	4761189
07	20.	20.07	07UWXQ2A20.N	4761070	08	20.	19.76	08UWXQ2A20.N	4761193
07	22.	21.89	07UWXQ2A22.N	4761074	08	22.	22.03	08UWXQ2A22.N	4761197
07	25.	24.59	07UWXQ2A25.N	4761078	08	25.	24.47	08UWXQ2A25.N	4761201
07	28.	27.03	07UWXQ2A28.N	4761082	08	28.	27.22	08UWXQ2A28.N	4761205
07	32.	30.81	07UWXQ2A32.N	4761087	08	32.	31.78	08UWXQ2A32.N	4761209
07	36.	35.31	07UWXQ2A36.N	4761091	08	36.	35.20	08UWXQ2A36.N	4761213
07	40.	40.15	07UWXQ2A40.N	4761095	08	40.	39.51	08UWXQ2A40.N	4761217
07	45.	44.13	07UWXQ2A45.N	4761100	08	45.	43.64	08UWXQ2A45.N	4761223
07	50.	49.90	07UWXQ2A50.N	4761105	08	50.	49.26	08UWXQ2A50.N	4761229
07	56.	53.63	07UWXQ2A56.N	4761110	08	56.	54.60	08UWXQ2A56.N	4761233
07	63.	61.62	07UWXQ2A63.N	4761115	08	63.	63.56	08UWXQ2A63.N	4761237
07	71.	69.00	07UWXQ2A71.N	4761120	08	71.	69.64	08UWXQ2A71.N	4761243
07	80.	75.56	07UWXQ2A80.N	4761125	08	80.	76.50	08UWXQ2A80.N	4761249
07	90.	88.26	07UWXQ2A90.N	4761130	08	90.	87.29	08UWXQ2A90.N	4761255
07	100	99.79	07UWXQ2A100N	4761135	08	100	98.53	08UWXQ2A100N	4761261
07	112	104.3	07UWXQ2A112N	4761140	08	112	102.4	08UWXQ2A112N	4761267
07	125	115.9	07UWXQ2A125N	4761145	08	125	117.9	08UWXQ2A125N	4761273
07	140	138.0	07UWXQ2A140N	4761150	08	140	139.3	08UWXQ2A140N	4761279
07	160	151.1	07UWXQ2A160N	4761155	08	160	153.0	08UWXQ2A160N	4761285
07	212	208.6	07UWXQ2A212N	4761160	08	212	204.8	08UWXQ2A212N	4761291
07	250	231.8	07UWXQ2A250N	4761165	08	250	235.8	08UWXQ2A250N	4761297

Continued on next page

UW – Gear Drive Part Numbers

Hollow Low Speed Shaft With Drywell – Flange Mounted – Double Reduction (Continued)

Drive Size	Ratio Code	Exact Ratio	Drive Designation	Drive Part No.	Drive Size	Ratio Code	Exact Ratio	Drive Designation	Drive Part No.
09	8.0	7.973	09UWXQ2A8.0N	4761301	10	8.0	7.951	10UWXQ2A8.0N	4763982
09	11.	10.98	09UWXQ2A11.N	4761305	10	11.	11.11	10UWXQ2A11.N	4763986
09	12.	12.30	08UWXQ2A12.N	4761309	10	12.	12.08	10UWXQ2A12.N	4763990
09	14.	13.81	09UWXQ2A14.N	4761313	10	14.	13.72	10UWXQ2A14.N	4763994
09	16.	16.68	09UWXQ2A16.N	4761317	10	16.	16.63	10UWXQ2A16.N	4763998
09	18.	17.79	09UWXQ2A18.N	4761321	10	18.	17.87	10UWXQ2A18.N	4764002
09	20.	19.88	09UWXQ2A20.N	4761325	10	20.	19.29	10UWXQ2A20.N	4764006
09	22.	22.96	09UWXQ2A22.N	4761329	10	22.	23.23	10UWXQ2A22.N	4764010
09	25.	25.73	09UWXQ2A25.N	4761333	10	25.	25.27	10UWXQ2A25.N	4764014
09	28.	28.89	09UWXQ2A28.N	4761337	10	28.	28.70	10UWXQ2A28.N	4764018
09	32.	31.43	09UWXQ2A32.N	4761341	10	32.	31.85	10UWXQ2A32.N	4764022
09	36.	37.22	09UWXQ2A36.N	4761345	10	36.	37.38	10UWXQ2A36.N	4764026
09	40.	41.59	09UWXQ2A40.N	4761349	10	40.	40.36	10UWXQ2A40.N	4764030
09	45.	44.55	09UWXQ2A45.N	4761355	10	45.	43.65	10UWXQ2A45.N	4764036
09	50.	49.49	09UWXQ2A50.N	4761361	10	50.	48.51	10UWXQ2A50.N	4764042
09	56.	57.66	09UWXQ2A56.N	4761365	10	56.	58.85	10UWXQ2A56.N	4764046
09	63.	65.74	09UWXQ2A63.N	4761369	10	63.	66.63	10UWXQ2A63.N	4764050
09	71.	69.91	09UWXQ2A71.N	4761375	10	71.	69.18	10UWXQ2A71.N	4764056
09	80.	77.18	09UWXQ2A80.N	4761381	10	80.	79.71	10UWXQ2A80.N	4764062
09	90.	93.18	09UWXQ2A90.N	4761387	10	90.	91.32	10UWXQ2A90.N	4764068
09	100	103.5	09UWXQ2A100N	4761393	10	100	101.5	10UWXQ2A100N	4764074
09	112	106.2	09UWXQ2A112N	4761399	10	112	107.8	10UWXQ2A112N	4764080
09	125	119.4	09UWXQ2A125N	4761405	10	125	115.8	10UWXQ2A125N	4764086
09	140	146.2	09UWXQ2A140N	4761411	10	140	144.7	10UWXQ2A140N	4764092
09	160	161.4	09UWXQ2A160N	4761417	10	160	166.7	10UWXQ2A160N	4764098
09	212	222.1	09UWXQ2A212N	4761423	10	212	225.5	10UWXQ2A212N	4764104
09	250	249.7	09UWXQ2A250N	4761429	10	250	242.3	10UWXQ2A250N	4764110

UW – Gear Drive Part Numbers

Hollow Low Speed Shaft With Drywell – Flange Mounted – Triple Reduction

Drive Size	Ratio Code	Exact Ratio	Drive Designation	Drive Part No.
07	100	97.33	07UWXQ3A100N	4761731
07	118	113.2	07UWXQ3A118N	4761735
07	132	125.0	07UWXQ3A132N	4761738
07	150	141.7	07UWXQ3A150N	4761741
07	160	160.0	06UWXQ3A160N	4761745
07	180	170.8	07UWXQ3A180N	4761749
07	200	194.7	07UWXQ3A200N	4761753
07	225	226.4	07UWXQ3A225N	4761757
07	265	249.9	07UWXQ3A265N	4761761
07	280	273.7	07UWXQ3A280N	4761765
07	315	320.0	07UWXQ3A315N	4761769
07	360	341.6	07UWXQ3A360N	4761773
07	400	373.8	07UWXQ3A400N	4761777
07	450	419.3	07UWXQ3A450N	4761781
07	500	499.9	07UWXQ3A500N	4761785
07	560	547.4	07UWXQ3A560N	4761789
07	800	747.7	07UWXQ3A800N	4761793
07	900	838.5	07UWXQ3A900N	4761797

Type UW Double Reduction Gear Drive

Sizes 03-06 — Dimensions — Inches

BASIC GEAR DRIVE HOLLOW LOW SPEED SHAFT

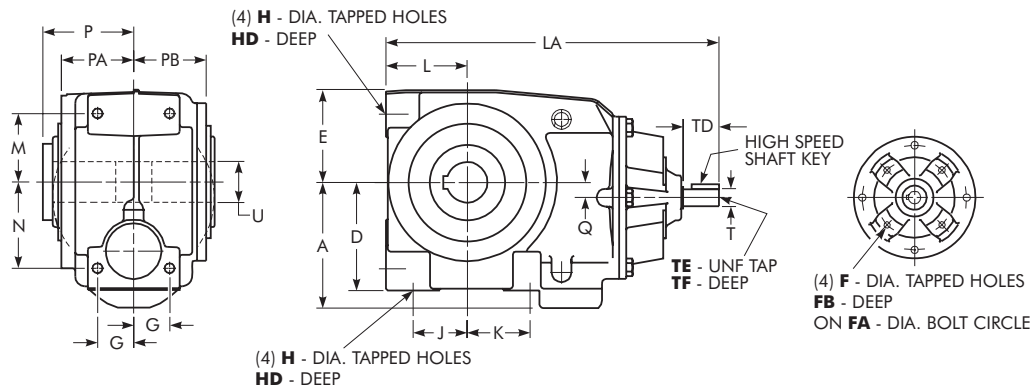

SIZE ★	A	D	E	F	FA	FB	G	H	HD	J	K	L
03	3.13	2.80	2.68	M8 x 1.25	3.54	0.63	1.06	M8 x 1.25	0.59	1.38	1.10	2.13
04	3.66	3.39	2.95	M8 x 1.25	3.54	0.63	1.10	M10 x 1.50	0.79	1.38	1.77	2.52
05	4.41	3.78	3.46	M8 x 1.25	3.54	0.63	1.34	M10 x 1.50	0.71	1.77	2.17	2.68
06	5.49	4.72	4.06	M10 x 1.50	4.53	0.67	1.57	M12 x 1.75	0.79	2.20	2.60	3.54

SIZE ★	LA	M	N	P	PA	PB	Q	H.S. Shaft		TD	TE	TF	Hollow L.S. Shaft	
								T + .0000 - .0005	Key				U + .0005 - .0000	Keyway
03	10.79	1.57	1.57	2.76	2.40	2.24	0.21	0.6250	.19 x .19 x 1.28	1.57	1/4	0.63	0.7500	.19 x .09 x 4.88
04	11.54	2.09	2.56	2.93	2.58	2.56	0.59	0.6250	.19 x .19 x 1.28	1.57	1/4	0.63	1.2500	.25 x .12 x 5.12
05	12.32	2.56	3.03	3.11	2.76	2.76	0.51	0.6250	.19 x .19 x 1.28	1.57	3/8	0.87	1.3750	.31 x .16 x 5.52
06	14.57	2.99	3.78	3.98	3.54	3.56	0.67	0.7500	.19 x .19 x 1.28	1.57	1/2	1.125	1.5000	.38 x .17 x 7.08

★ Refer to Page 6 for General Information and Reference Notes.

Type UW Triple Reduction Gear Drive

Sizes 03-06 — Dimensions – Inches

BASIC GEAR DRIVE HOLLOW LOW SPEED SHAFT

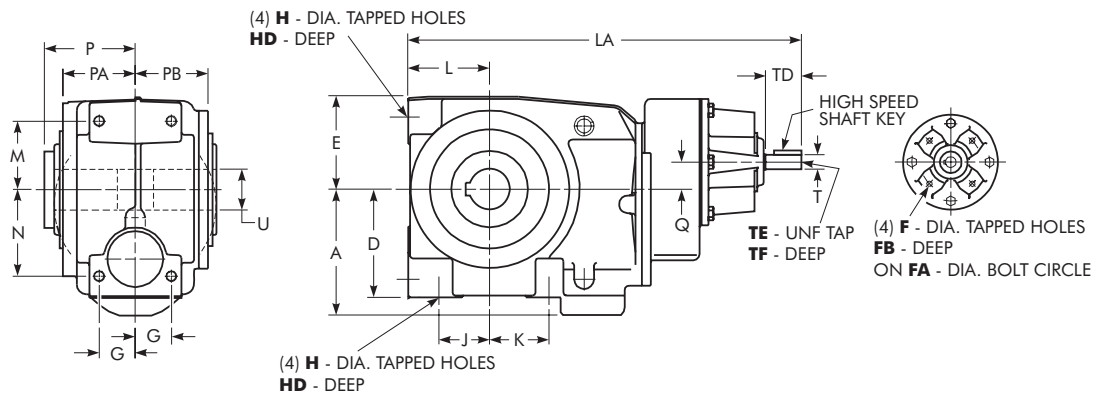

SIZE ★	A	D	E	F	FA	FB	G	H	HD	J	K	L
03	3.13	2.80	2.68	M8 x 1.25	3.54	0.63	1.06	M8 x 1.25	0.59	1.38	1.10	2.13
04	3.66	3.39	2.95	M8 x 1.25	3.54	0.63	1.10	M10 x 1.50	0.79	1.38	1.77	2.52
05	4.41	3.78	3.46	M8 x 1.25	3.54	0.63	1.34	M10 x 1.50	0.71	1.77	2.17	2.68
06	5.49	4.72	4.06	M10 x 1.50	4.53	0.63	1.57	M12 x 1.75	0.79	2.20	2.60	3.54

SIZE ★	LA	M	N	P	PA	PB	Q	H.S. Shaft		TD	TE	TF	Hollow L.S. Shaft	
								T +.0000 -.0005	Key				U +.0005 -.0000	Keyway
03	12.99	1.57	1.57	2.76	2.40	2.24	1.21	0.6250	.19 x .19 x 1.28	1.57	1/4	0.49	0.7500	.19 x .09 x 4.88
04	13.74	2.09	2.56	2.93	2.58	2.56	0.83	0.6250	.19 x .19 x 1.28	1.57	1/4	0.49	1.2500	.25 x .12 x 5.12
05	14.53	2.56	3.03	3.11	2.76	2.76	0.91	0.6250	.19 x .19 x 1.28	1.57	1/4	0.49	1.3750	.31 x .16 x 5.52
06	17.17	2.99	3.78	3.98	3.54	3.56	1.18	0.7500	.19 x .19 x 1.28	1.57	1/4	0.49	1.5000	.38 x .17 x 7.08

★ Refer to Page 6 for General Information and Reference Notes.

Type UW Quadruple Reduction Gear Drive

Size 06 — Dimensions – Inches

BASIC GEAR DRIVE HOLLOW LOW SPEED SHAFT

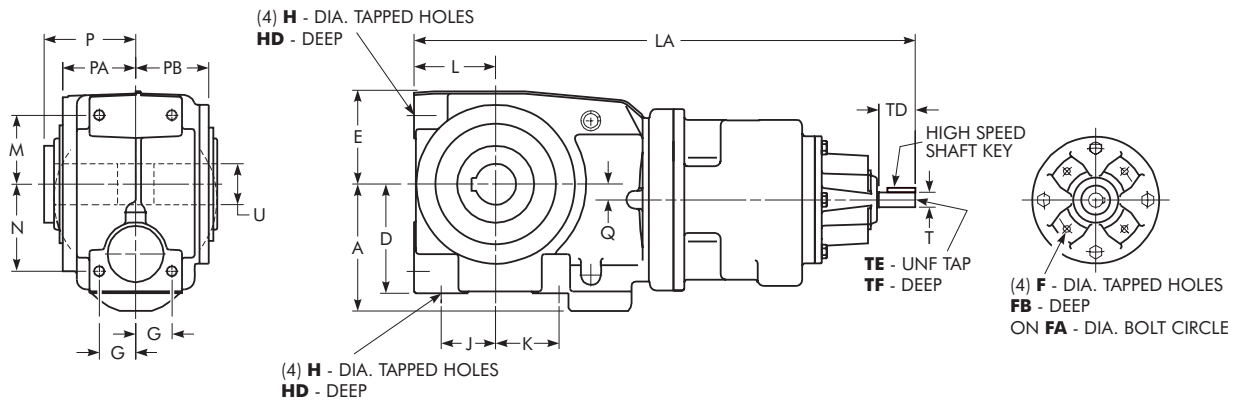

SIZE ★	A	D	E	F	FA	FB	G	H	HD	J	K	L
06	5.49	4.72	4.06	M8 x 1.25	0.63	3.54	1.57	M12 x 1.75	0.79	2.20	2.60	3.54

SIZE ★	LA	M	N	P	PA	PB	Q	H.S. Shaft		TD	TE	TF	Hollow L.S. Shaft	
								T +.0000 -.0005	Key				U +.0005 -.0000	Keyway
06	20.98	2.99	3.78	3.98	3.54	3.56	0.67	0.6250	.19 x .19 x 1.28	1.57	1/4	0.49	1.5000	.38 x .17 x 7.08

★ Refer to Page 6 for General Information and Reference Notes.

Type UW Quintuple Reduction Gear Drive

Size 06 — Dimensions – Inches

BASIC GEAR DRIVE HOLLOW LOW SPEED SHAFT

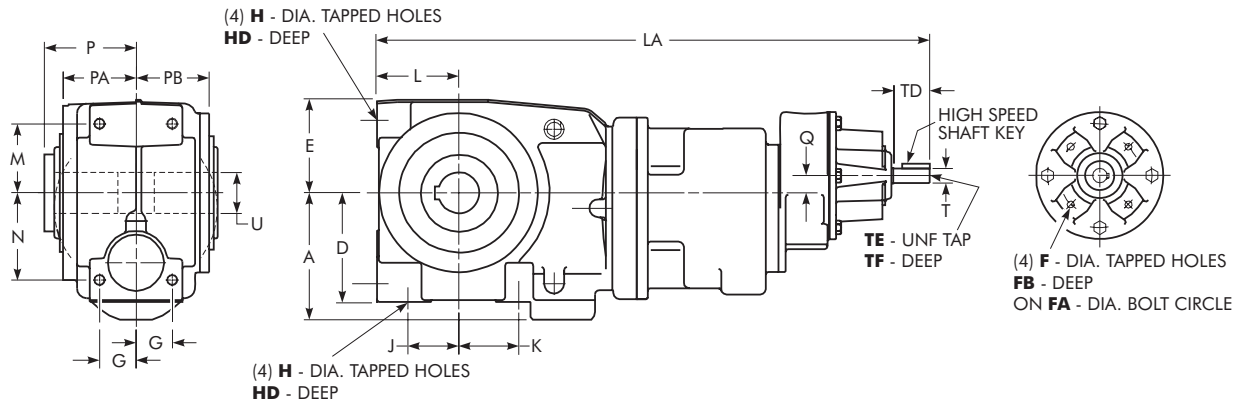

SIZE ★	A	D	E	F	FA	FB	G	H	HD	J	K	L
06	5.49	4.72	4.06	M8 x 1.25	0.63	3.54	1.57	M12 x 1.75	0.79	2.20	2.60	3.54

SIZE ★	LA	M	N	P	PA	PB	Q	H.S. Shaft		TD	TE	TF	Hollow L.S. Shaft	
								T + .0000 - .0005	Key				U + .0005 - .0000	Keyway
06	23.98	2.99	3.78	3.98	3.54	3.56	0.75	0.6250	.19 x .19 x 1.28	1.57	1/4	0.49	1.5000	.38 x .17 x 7.08

★ Refer to Page 6 for General Information and Reference Notes.

Type UW Double Reduction Gear Drive

Sizes 07-10 — Dimensions — Inches

BASIC GEAR DRIVE HOLLOW LOW SPEED SHAFT INTEGRAL BASE MOUNTED FEET

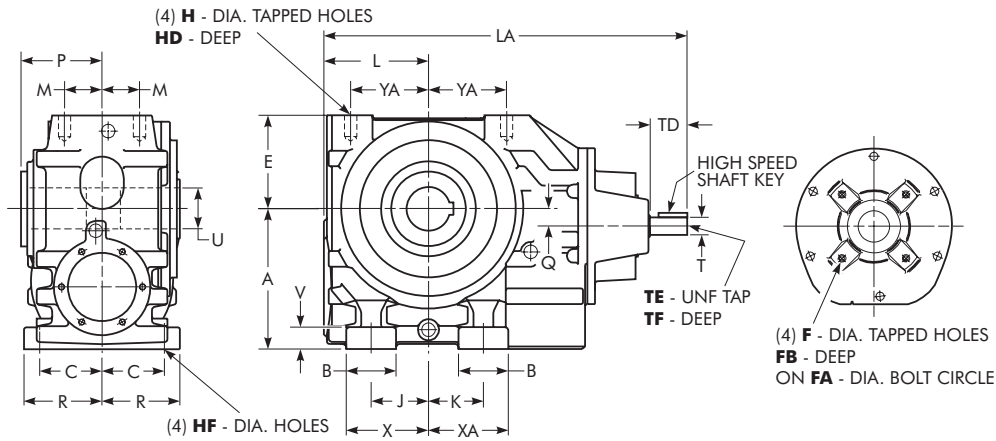

SIZE ★	A	B	C	E	F	FA	FB	H	HD	HF	J	K	L	LA	M
07	7.1	2.64	2.95	4.80	M12 x 2.50	5.71	0.79	M20 x 2.50	1.34	0.71	2.95	2.36	5.63	18.82	1.97
08	8.9	3.15	3.94	5.91	M12 x 1.75	5.71	0.79	M20 x 2.50	1.34	0.87	3.62	3.46	6.61	22.95	2.36
09	11.0	3.35	4.92	6.97	M16 x 2.00	6.89	1.18	M24 x 3.00	1.77	1.02	4.53	4.72	7.68	27.17	2.66
10	13.2	4.33	5.91	9.06	M20 x 2.50	8.27	1.14	M24 x 3.00	1.77	1.02	6.69	5.51	9.25	32.40	2.95

SIZE ★	P	Q	R	H.S. Shaft		TD	TE	TF	Hollow L.S. Shaft		V	X	XA	YA
				T + .0000 - .0005	Key				U + .001 - .000	Keyway				
07	4.90	1.02	3.64	0.8750	.19 x .19 x 1.28	1.97	5/8	1.44	2.000	.50 x .23 x 8.58	1.10	4.27	3.68	4.23
08	5.63	1.10	4.92	1.1250	.25 x .25 x 2.00	2.36	3/4	1.75	2.375	.63 x .29 x 9.84	1.38	5.20	5.04	4.92
09	6.65	1.57	6.00	1.3750	.31 x .31 x 2.40	3.15	3/4	1.75	2.750	.63 x .29 x 11.82	1.57	6.20	6.40	5.71
10	7.80	2.56	7.09	1.6250 †	.38 x .38 x 3.69	4.33	1	2.25	3.250	.75 x .34 x 13.78	1.77	8.86	7.68	6.79

★ Refer to Page 6 for General Information and Reference Notes.

† Tolerance is +.0000 - .0010.

Type UW Triple Reduction Gear Drive

Size 07 — Dimensions – Inches

BASIC GEAR DRIVE HOLLOW LOW SPEED SHAFT INTEGRAL BASE MOUNTED FEET

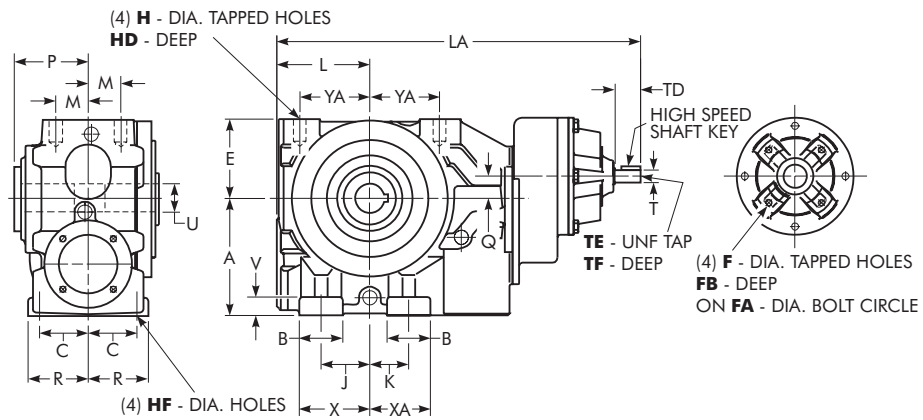

SIZE ★	A	B	C	E	F	FA	FB	H	HD	HF	J	K	L	LA	M
07	7.1	2.64	2.95	4.80	M10 x 1.50	4.53	0.67	M20 x 2.50	1.34	0.71	2.95	2.36	5.63	22.05	1.97

SIZE ★	P	Q	R	H.S. Shaft		TD	TE	TF	Hollow L.S. Shaft		V	X	XA	YA
				T +.0000 -.0005	Key				U +.001 -.000	Keyway				
07	4.90	1.34	3.64	0.7500	.19 x .19 x 1.28	1.57	5/8	1.44	2.000	.50 x .23 x 8.58	1.10	4.27	3.68	4.23

★ Refer to Page 6 for General Information and Reference Notes.

Type UW Quadruple Reduction Gear Drive

Sizes 07-10 — Dimensions — Inches

BASIC GEAR DRIVE HOLLOW LOW SPEED SHAFT INTEGRAL BASE MOUNTED FEET

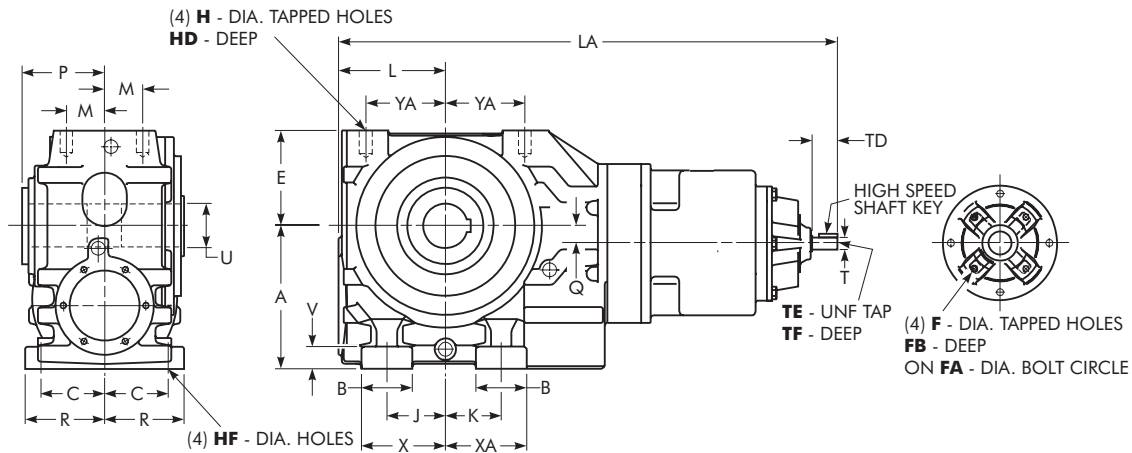

SIZE ★	A	B	C	E	F	FA	FB	H	HD	HF	J	K	L	LA	M
07	7.1	2.64	2.95	4.80	M8 x 1.25	3.54	0.63	M20 x 2.50	1.34	0.71	2.95	2.36	5.63	26.14	1.97
08	8.9	3.15	3.94	5.91	M10 x 1.50	4.53	0.67	M20 x 2.50	1.34	0.87	3.62	3.46	6.61	30.91	2.36
09	11.0	3.35	4.92	6.97	M10 x 1.50	4.53	0.67	M24 x 3.00	1.77	1.02	4.53	4.72	7.68	34.17	2.66
10	13.2	4.33	5.91	9.06	M12 x 1.75	5.71	0.79	M24 x 3.00	1.77	1.02	6.69	5.51	9.25	39.25	2.95

SIZE ★	P	Q	R	H.S. Shaft		TD	TE	TF	Hollow L.S. Shaft		V	X	XA	YA
				T +.0000 -.0005	Key				U +.001 -.000	Keyway				
07	4.90	1.02	3.64	0.6250	.19 x .19 x 1.28	1.57	5/8	1.44	2.000	.50 x .23 x 8.58	1.10	4.27	3.68	4.23
08	5.63	1.10	4.92	0.7500	.19 x .19 x 1.28	1.57	3/4	1.75	2.375	.63 x .29 x 9.84	1.38	5.20	5.04	4.92
09	6.65	1.57	6.00	0.7500	.19 x .19 x 1.28	1.57	3/4	1.75	2.750	.63 x .29 x 11.82	1.57	6.20	6.40	5.71
10	7.80	2.56	7.09	0.8745	.19 x .19 x 1.28	1.97	5/16	0.63	3.250	.75 x .34 x 13.78	1.77	8.86	7.68	6.79

★ Refer to Page 6 for General Information and Reference Notes.

Type UW Quintuple Reduction Gear Drive

Sizes 07-10 — Dimensions – Inches

BASIC GEAR DRIVE HOLLOW LOW SPEED SHAFT INTEGRAL BASE MOUNTED FEET

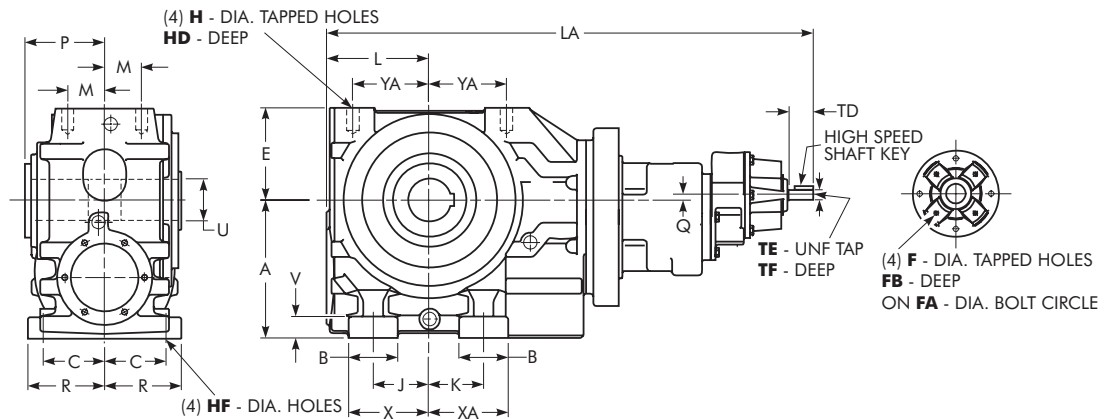

SIZE ★	A	B	C	E	F	FA	FB	H	HD	HF	J	K	L	LA	M
07	7.1	2.64	2.95	4.80	M8 x 1.25	3.54	0.63	M20 x 2.50	1.34	0.71	2.95	2.36	5.63	28.34	1.97
08	8.9	3.15	3.94	5.91	M8 x 1.25	3.54	0.63	M20 x 2.50	1.34	0.87	3.62	3.46	6.61	31.22	2.36
09	11.0	3.35	4.92	6.97	M8 x 1.25	3.54	0.63	M24 x 3.00	1.77	1.02	4.53	4.72	7.68	36.77	2.66
10	13.2	4.33	5.91	9.06	M8 x 1.25	3.54	0.63	M24 x 3.00	1.77	1.02	6.69	5.51	9.25	39.84	2.95

SIZE ★	P	Q	R	H.S. Shaft		TD	TE	TF	Hollow L.S. Shaft		V	X	XA	YA
				T +.0000 -.0005	Key				U +.001 -.000	Keyway				
07	4.90	0.39	3.64	0.6250	.19 x .19 x 1.28	1.57	1/4	0.49	2.000	.50 x .23 x 8.58	1.10	4.27	3.68	4.23
08	5.63	0.32	4.92	0.6250	.19 x .19 x 1.28	1.57	1/4	0.49	2.375	.63 x .29 x 9.84	1.38	5.20	5.04	4.92
09	6.65	0.28	6.00	0.6250	.19 x .19 x 1.28	1.57	1/4	0.49	2.750	.63 x .29 x 11.82	1.57	6.20	6.40	5.71
10	7.80	0.71 ‡	7.09	0.6250	.19 x .19 x 1.28	1.57	1/4	0.49	3.250	.72 x .34 x 13.78	1.77	8.86	7.68	6.79

★ Refer to Page 6 for General Information and Reference Notes.

‡ Dimension is below the centerline.

Type UW Double Reduction Gear Drive

Sizes 07-10 — Dimensions — Inches

BASIC GEAR DRIVE HOLLOW LOW SPEED SHAFT WITH DRYWELL FLANGE MOUNTED

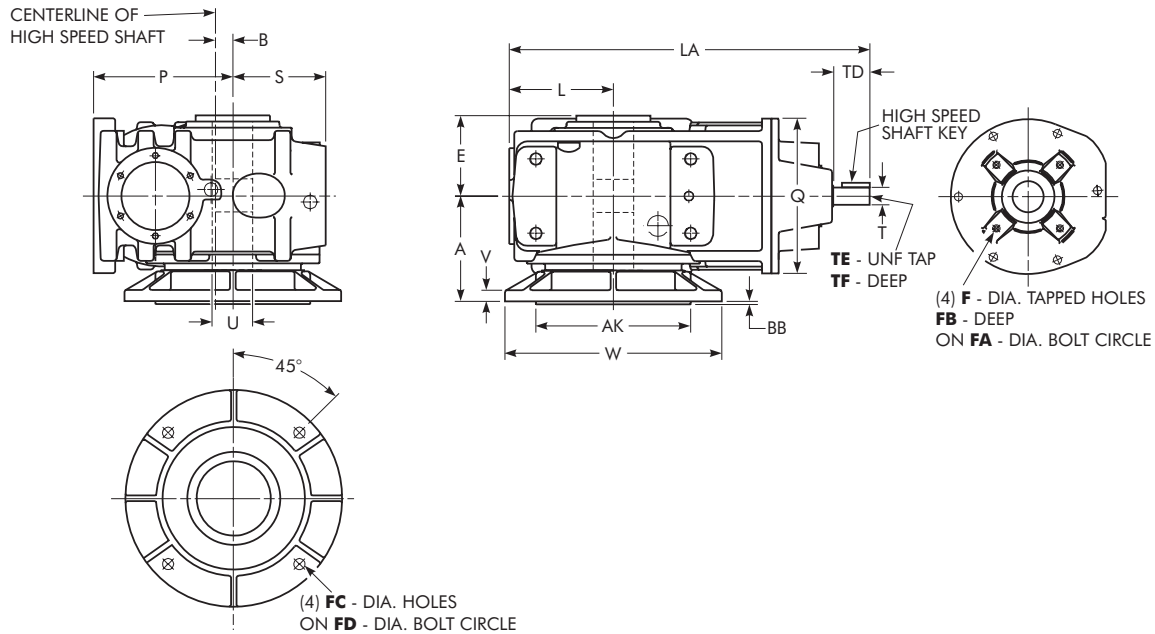

SIZE ★	A	AK	B	BB	E	F	FA	FB	FC	FD	L	LA
07	5.43	7.09	1.02	0.16	4.90	M12 x 1.75	5.71	0.79	0.55	8.46	5.63	18.82
08	6.69	9.84	1.10	0.20	5.63	M12 x 1.75	5.71	0.79	0.71	11.81	6.61	22.95
09	7.87	13.78	1.57	0.20	6.65	M16 x 2.00	6.89	1.18	0.71 ‡	15.75	7.68	27.17
10	9.13	13.78	2.56	0.20	7.80	M20 x 2.50	8.27	1.14	0.71 ‡	15.75	9.25	32.40

‡ Size 09 & 10 have (8) FC - DIA. HOLES.

SIZE ★	P	Q	S	H.S. Shaft		TD	TE	TF	Hollow L.S. Shaft		V	W
				T + .0000 - .0005	Key				U + .001 - .000	Keyway		
07	7.1	8.35	4.80	0.8750	.19 x .19 x 1.28	1.97	5/16	0.63	2.000	.50 x .23 x 8.58	0.47	9.84
08	8.9	9.84	5.91	1.1250	.25 x .25 x 2.00	2.36	3/8	0.87	2.375	.63 x .29 x 9.84	0.71	13.78
09	11.0	11.81	6.97	1.3750	.31 x .31 x 2.40	3.15	1/2	1.10	2.750	.63 x .29 x 11.82	0.79	17.72
10	13.2	14.17	9.06	1.6250	.38 x .38 x 3.69	4.33	5/8	1.42	3.250	.75 x .34 x 13.78	0.87	17.72

★ Refer to Page 6 for General Information and Reference Notes.

Type UW Triple Reduction Gear Drive

Sizes 07 — Dimensions – Inches

BASIC GEAR DRIVE HOLLOW LOW SPEED SHAFT WITH DRYWELL FLANGE MOUNTED

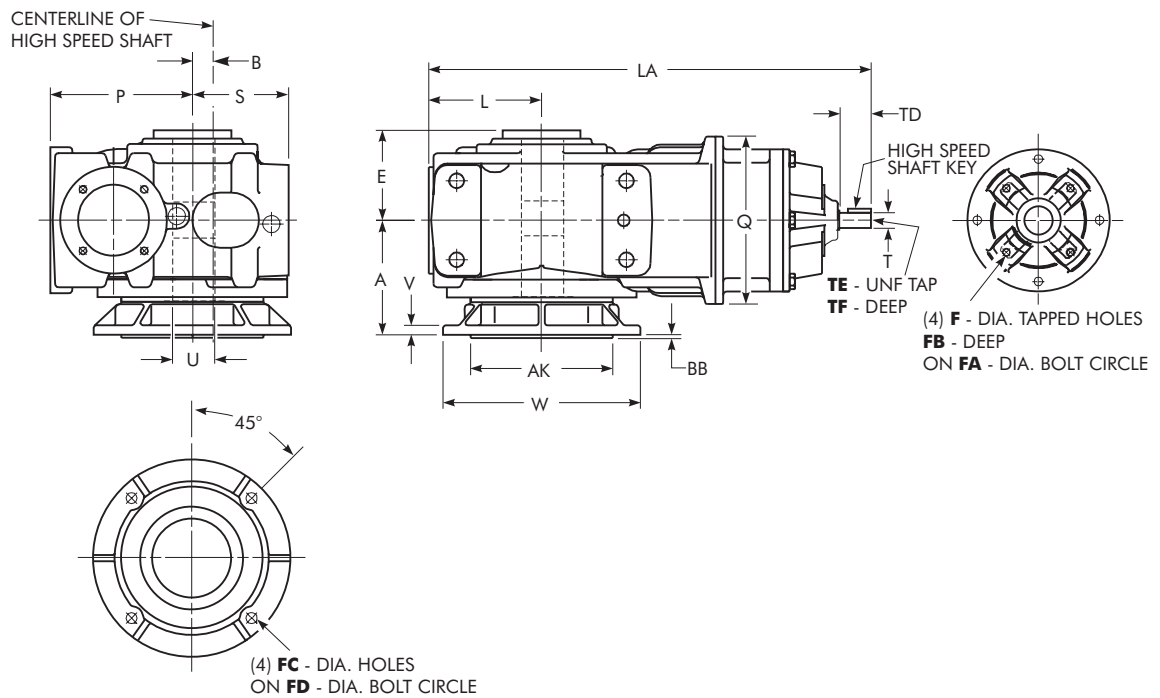

SIZE ★	A	AK	B	BB	E	F	FA	FB	FC	FD	L	LA
07	5.43	7.09	1.34	0.16	4.90	M10 x 1.50	4.53	0.67	0.55	8.46	5.63	22.05

SIZE ★	P	Q	S	H.S. Shaft		TD	TE	TF	Hollow L.S. Shaft		V	W
				T +.0000 -.0005	Key				U +.001 -.000	Keyway		
07	7.1	7.09	4.80	0.7500	.19 x .19 x 1.28	1.57	1/4	0.63	2.000	.50 x .23 x 8.58	0.47	9.84

★ Refer to Page 6 for General Information and Reference Notes.

UW – Accessories

Output Flange Kits

04UWF/UFF/UBF – Standard Output Flange

03UWG – Reduced Diameter Output Flange

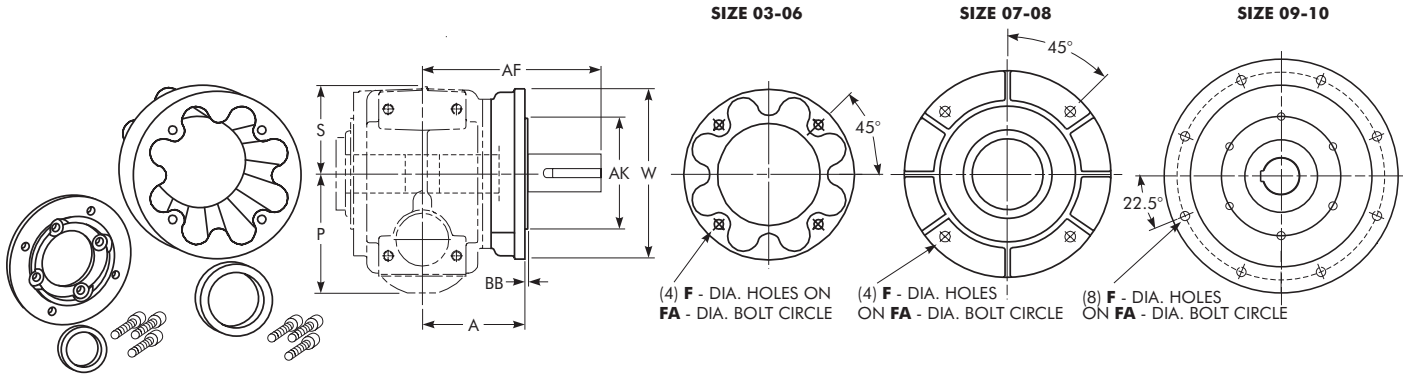

DIMENSIONS – INCHES

DRIVE SIZE *	A	AF	AK	BB	F	FA	P	S	W	Kit Part Number	Output Shaft Kit Part Number Single Extension Left or Right Hand Used With Output Flange Drive Only
03	2.95	...	4.3312 †	0.16	0.35	5.12	3.13	2.68	6.30	1940545	...
03 (Red. Dia.)	2.95	...	3.1501 †	0.12	0.26	3.94	3.13	2.68	4.72	1940546	...
04	3.39	...	4.3312 †	0.14	0.35	5.12	3.66	2.95	6.30	1940547	...
05	4.21	...	5.1187 †	0.14	0.43	6.50	4.41	3.46	7.87	1940548	...
06	4.72	...	5.1187 †	0.14	0.43	6.50	5.49	4.06	7.87	1940549	...
07	5.43	6.85	7.09	0.16	0.55	8.46	7.1	4.80	9.84	1940550	1941014
08	6.69	8.46	9.84	0.20	0.71	11.81	8.9	5.91	13.78	1940551	1941015
09	7.87	9.84	13.78	0.20	0.71	15.75	11.0	6.97	17.72	1940552	1941016
10	9.13	11.43	13.78	0.20	0.71	15.75	13.2	9.06	17.72	1940779	1940777

★ Refer to Page 6 for General Information and Reference Notes.

† Tolerance is +.0000 –.0008.

‡ Tolerance is +.0000 –.0010.

Banjo Torque Arm Kits

03UWK – Drive With Banjo Torque Arm

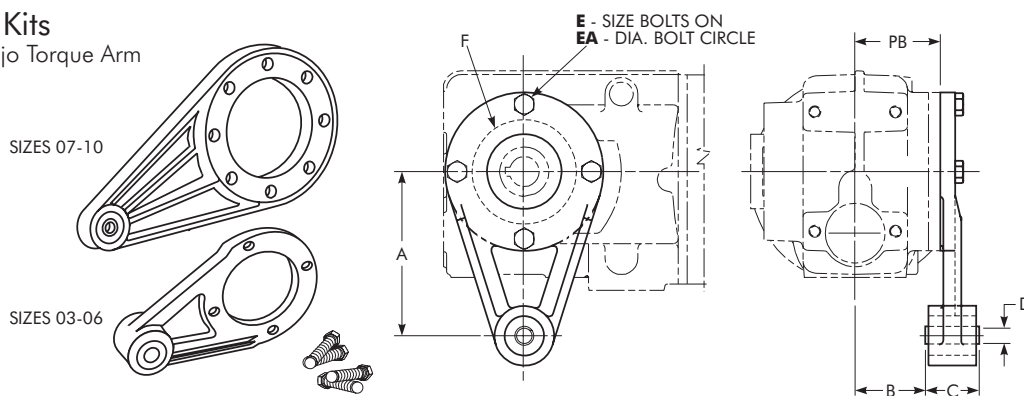

DIMENSIONS – INCHES

DRIVE SIZE *	A	B	C	D	E	EA	F (Register Dia)	PB	Kit Part Number Sizes 03-06	Kit Part Number Sizes 07-09
03	4.33	1.85	1.42	0.41	4 x M8	3.54	2.7555/2.7547	2.40	1940570	...
04	5.12	2.05	1.42	0.41	8 x M8	4.21	3.3461/3.3452	2.44	1940571	...
05	6.30	2.05	1.42	0.41	8 x M8	5.12	4.1335/4.1326	2.44	1940572	...
06	7.87	2.81	1.73	0.65	8 x M10	6.10	4.9209/4.9199	3.17	1940573	...
07	9.84	3.05	2.36	0.65	6 x M12	6.10	...	4.09	...	1940574
08	12.20	3.37	2.36	0.65	8 x M12	7.68	...	4.72	...	1940575
09	14.96	3.86	3.15	0.98	6 x M16	9.06	...	5.67	...	1940576
10	16.93	5.39	3.15	0.98	10 x M16	11.02	...	6.55	...	1940782

★ Refer to Page 6 for General Information and Reference Notes.

UW – Accessories

Base & End Mounted Foot Kits — Sizes 03-06

03UWC – Drive With Base Mounted Feet

03UWD – Drive With End Mounted Feet

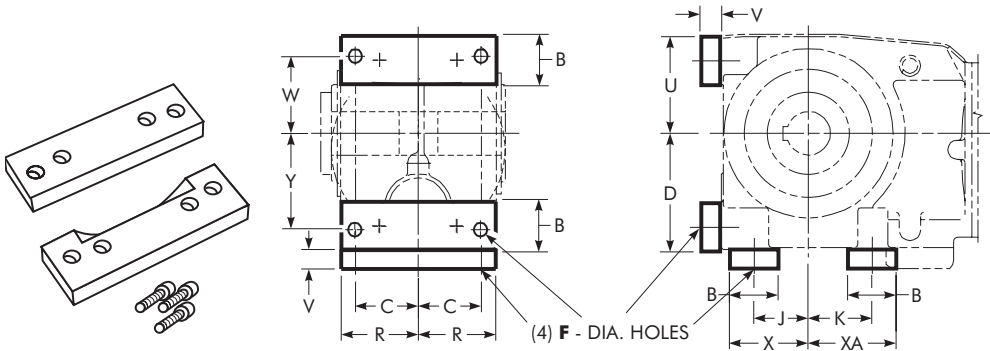

Drive Mounting Bolts Max Permissible Size

DRIVE SIZE	Metric Bolt	Inch Bolt
03	M8	5/16
04	M10	3/8
05	M10	3/8
06	M12	1/2
07	M16	5/8
08	M20	3/4
09	M24	1
10	M24	1

DIMENSIONS – INCHES

DRIVE SIZE *	B	C	D	F	J	K	R	U	V	W	X	XA	Y	Base & End Foot Mount Kit Part Number
03	0.98	1.77	2.07	0.35	1.38	1.10	2.17	2.07	0.35	1.57	1.85	1.61	1.57	1940556
04	1.38	1.97	3.25	0.43	1.38	1.77	2.44	2.78	0.55	2.09	2.09	2.44	2.56	1940557
05	1.57	2.17	3.82	0.43	1.77	2.17	2.68	3.35	0.63	2.56	2.56	2.95	3.03	1940558
06	1.97	2.56	4.76	0.55	2.36	2.76	3.15	3.98	0.79	3.15	3.19	3.58	3.94	1940559

* Refer to Page 6 for General Information and Reference Notes.

End & Top Mounted Foot Kits — Sizes 07-10

07UWE – Drive With Top Mounted Feet

07UWD – Drive With End Mounted Feet

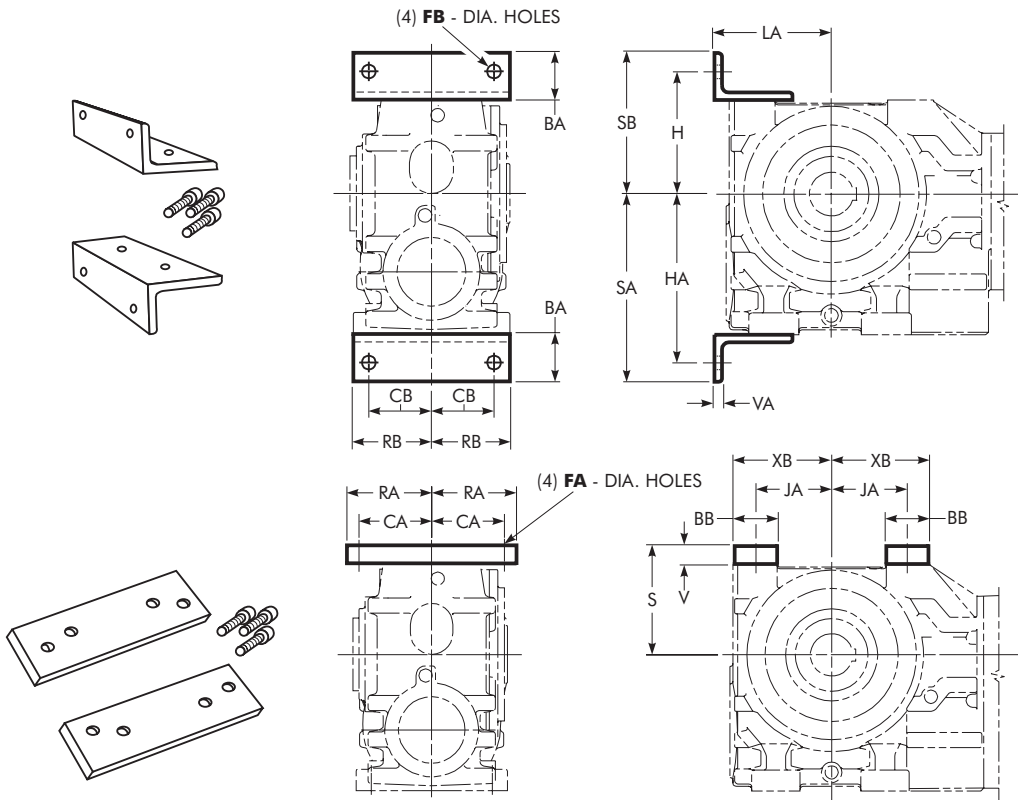

DIMENSIONS – INCHES

DRIVE SIZE *	BA	BB	CA	CB	FA	FB	H	HA	JA	LA	RA	RB	S	SA	SB	V	VA	End Mount Kit Part Number	Top Mount Kit Part Number
07	2.95	2.48	4.04	3.35	0.94	0.87	6.57	8.86	4.23	6.38	5.04	4.33	5.91	10.04	7.76	1.10	0.47	1940564	1940567
08	2.95	2.76	4.43	3.94	0.94	0.87	7.68	10.63	4.92	7.36	5.51	4.92	7.09	11.81	8.86	1.38	0.47	1940565	1940568
09	3.54	3.15	4.72	4.92	1.10	1.02	8.94	12.99	5.71	8.66	5.91	6.00	8.35	14.57	10.51	1.57	0.59	1940566	1940569
10	3.54	3.94	5.22	5.91	1.10	1.02	11.02	15.16	6.79	10.23	6.50	7.09	10.43	16.53	12.60	1.77	0.59	1940780	1940781

* Refer to Page 6 for General Information and Reference Notes.

UW – Accessories

Output Shaft Kits — Single & Double Ended When Viewed From L.S. End

NOTE: When L.S.S. is to be mounted, indicate L.H. or R.H. when viewing drive from L.S. End.

- 03UW_B – Single Ended L.H. (Left Hand)
- 03UW_C – Single Ended R.H. (Right Hand)
- 03UW_D – Double Ended

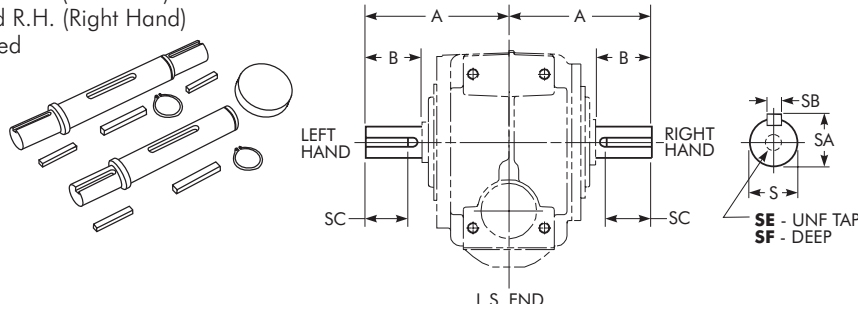

DIMENSIONS – INCHES

DRIVE SIZE *	A	B	SC	SE	SF	Single Extension			Double Extension			Kit Part Number Single Extension Left or Right Hand	Kit Part Number Double Extension
						S	SA	SB	S	SA	SB		
03	3.94	1.38	1.1875	1/4	0.63	0.7500 †	0.83	0.1875	0.7500 †	0.83	0.1875	1940531	1940538
04	4.53	1.81	1.5625	1/4	0.63	1.0000 †	1.10	0.2500	1.0000 †	1.10	0.2500	1940532	1940539
05	5.28	2.36	2.0000	3/4	0.87	1.2500 †	1.36	0.2500	1.2500 †	1.36	0.2500	1940533	1940540
06	6.30	2.48	2.1875	1/2	1.12	1.3750 †	1.51	0.3125	1.3750 †	1.51	0.3125	1940534	1940541
07	7.68	2.99	2.6875	5/8	1.44	1.7500 †	1.91	0.3750	1.7500 †	1.91	0.3750	1940535	1940542
08	10.04	4.72	4.1875	3/4	1.75	2.3750 †	2.64	0.6250	2.3125 †	2.58	0.6250	1940536	1940543
09	11.61	5.31	4.6875	3/4	1.75	2.8750 •	3.20	0.7500	2.6875 •	2.96	0.6250	1940537	1940544
10	14.41	6.69	6.3281	1	2.25	3.6250 •	4.009	0.8750	3.1875 •	3.52	0.7500	1940776	1940778

★ Refer to Page 6 for General Information and Reference Notes.

† Tolerance is +.0000 –.0005.

‡ Tolerance is +.0000 –.0006.

• Tolerance is +.0000 –.0010..

Customer Shaft

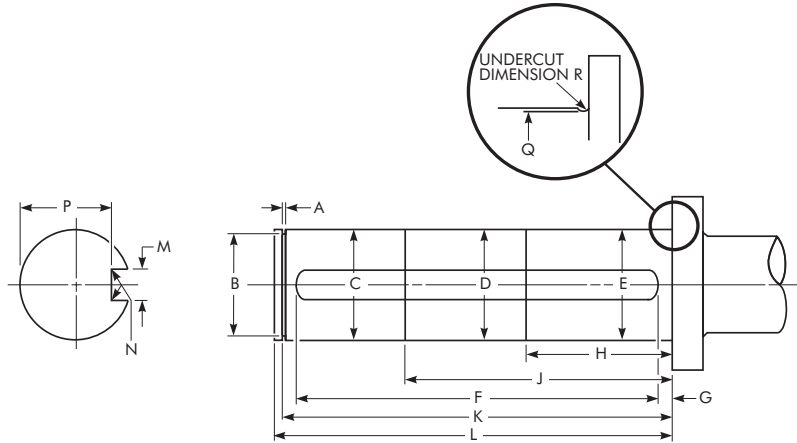

DIMENSIONS – INCHES

Drive Size *	A	B	C	D	E	F	G	H	J	K	L	M	N	P	Q	R
03	0.049 0.043	0.707 0.701	0.7497 0.7492	0.7497 0.7492	2.731 2.719	1.06	4.930 4.926	5.00	0.198 0.197	0.01R	0.644 0.638	0.710	0.03R
04	0.060 0.056	1.180 1.172	1.2486 1.2480	1.2486 1.2480	3.887 3.875	0.62	5.174 5.170	5.28	0.250 0.249	0.01R	1.112 1.106	1.210	0.03R
05	0.060 0.056	1.295 1.287	1.3746 1.3740	1.3746 1.3740	3.575 3.563	0.97	5.568 5.564	5.67	0.312 0.311	0.01R	1.201 1.195	1.335	0.03R
06	0.060 0.056	1.410 1.402	1.4996 1.4990	1.4996 1.4990	3.262 3.250	1.72	7.142 7.138	7.32	0.375 0.374	0.01R	1.289 1.283	1.480	0.03R
07	0.072 0.068	1.891 1.881	2.0000 1.9988	1.985 1.975	2.0000 1.9988	8.020 8.000	0.28	3.11	5.47	8.654 8.652	8.86	0.500 0.499	0.02R	1.718 1.712	1.920	0.05R
08	0.091 0.086	2.245 2.233	2.3750 2.3741	2.360 2.350	2.3750 2.3741	9.270 9.250	0.28	3.54	6.30	9.930 9.928	10.16	0.625 0.624	0.02R	2.021 2.015	2.275	0.05R
09	0.108 0.103	2.608 2.596	2.7500 2.7491	2.735 2.725	2.7500 2.7491	11.270 11.250	0.28	4.23	7.58	11.913 11.911	12.17	0.625 0.624	0.02R	2.402 2.396	2.670	0.05R
10	0.108 0.103	3.082 3.070	3.2500 3.2488	3.235 3.225	3.2500 3.2488	13.020 13.000	0.39	5.22	8.56	13.882 13.880	14.13	0.750 0.749	0.02R	2.831 2.825	3.170	0.05R

★ Refer to Page 6 for General Information and Reference Notes.

UW – Hollow Output Shaft

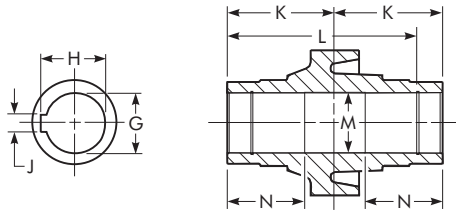

DIMENSIONS – INCHES

DRIVE SIZE	03	04	05	06	07	08	09	10
Dimensions								
G	0.7505 0.7500	1.2505 1.2500	1.3755 1.3750	1.5005 1.5000	2.0010 2.0000	2.3760 2.3750	2.7510 2.7500	3.2510 3.2500
H	0.84	1.37	1.53	1.67	2.23	2.66	3.04	3.59
J	0.19	0.25	0.31	0.375	0.50	0.63	0.63	0.75
K	2.44	2.56	2.76	3.54	4.29	4.92	5.91	6.89
L	†	†	†	†	7.48	8.76	10.75	12.44
M	0.76	1.26	1.39	1.51	2.02	2.40	2.76	3.26
N	2.05	2.13	2.20	2.76	3.11	3.54	4.23	5.22

† Sizes 03-06 do not have snap ring grooves, therefore no "L" dimension is required.

UW – Approximate Shipping Weights – lb ★

DRIVE SIZE	Motor Frame Size																												
	56C		143TC		145TC		182TC		184TC		213TC		215TC		254TC		256TC		284TC		286TC		324TC		326TC				
	Gearmotor Without Motor																												
	Base	Flange	Base	Flange	Base	Flange	Base	Flange	Base	Flange	Base	Flange	Base	Flange	Base	Flange	Base	Flange	Base	Flange	Base	Flange	Base	Flange	Base	Flange	Base	Flange	
03UW2	27	29	27	29	27	29	29	32	29	32																			
03UW3	34	37	34	37	34	37	37	39	37	39																			
04UW2	33	35	33	35	33	35	36	38	36	38																			
04UW3	41	43	41	43	41	43	44	45	44	45																			
05UW2	38	39	38	39	38	39	41	42	41	42																			
05UW3	46	47	47	47	47	47	47	50	49	50																			
06UW2	70	70	70	70	70	70	85	85	85	85	85	85	85	85															
06UW3	83	82	83	82	83	82	86	85	86	85																			
06UW4	105	105	105	105	105	105																							
07UW2	157	168	157	168	157	168	170	181	170	181	170	181	170	181	170	181	170	181											
07UW3	178	189	178	189	178	189	193	204	193	204	193	204	193	204															
07UW4	189	200	189	196	189	196																							
07UW5	198	209	198	209	198	209																							
08UW2	266	287	266	287	266	287	266	287	266	287	266	281	266	287	266	287	266	287											
08UW4	306	328	306	328	306	328	322	344	322	344	322	344	322	344															
08UW5	302	324	302	324	302	324																							
09UW2	396	428	396	428	396	428	396	428	412	434	412	434	417	439	417	439	421	443	421	443			
09UW4	456	489	456	489	456	489	471	514	471	514	471	514	471	514															
09UW5	467	500	467	500	467	500	471	504	471	504																			
10UW2	612	670	612	670	612	670	612	670	631	689	631	689	636	694	636	694	650	708	650	708			
10UW4	714	771	714	771	714	771	727	784	727	784	727	784	727	784															
10UW5	676	734	676	734	676	734	691	749	691	749	691	749	691	749															

DRIVE SIZE	Gearmotor With Motor																											
	Base	Flange	Base	Flange	Base	Flange	Base	Flange	Base	Flange	Base	Flange	Base	Flange	Base	Flange	Base	Flange	Base	Flange	Base	Flange	Base	Flange	Base	Flange	Base	Flange
03UW2	52	54	57	59	67	69	84	87	106	109																		
03UW3	59	62	64	67	74	77																						
04UW2	58	60	63	65	73	75	91	93	113	115																		
04UW3	66	68	71	73	81	82																						
05UW2	63	64	68	69	78	79	96	97	118	119																		
05UW3	71	72	76	77	86	87																						
06UW2	95	95	100	100	110	110	140	140	162	162	201	201	242	242														
06UW3	108	107	113	112	123	122	141	140	163	162																		
06UW4	130	130																										
07UW2	182	193	187	198	197	208	225	236	247	258	286	297	327	338	476	487	453	464										
07UW3	203	214	208	219	218	229	248	259	270	281																		
07UW4	214	225																										
07UW5																												
08UW2	291	312	296	317	306	327	321	342	343	364	382	403	423	444	572	593	549	570										
08UW4	331	353	336	358	346	368	377	399																				
08UW5																												
09UW2	451	483	473	505	511	543	553	585	718	740	695	717	846	868	863	885	944	966	1071	1093		
09UW4	481	514	486	519	496	529	526	569	548	591																		
09UW5																												
10UW2	667	725	689	747	727	785	769	827	937	995	914	972	1065	1123	1082	1140	1173	1231	1300	1358		
10UW4	739	796	744	801	754	811	782	839	804	861																		
10UW5																												

★ All weights exclude lubricant.

DRIVE SIZE	Inline Drive	
	Base	Flange
03UW2	25	27
03UW3	33	35
04UW2	34	35
04UW3	42	43
05UW2	47	43
05UW3	50	51
06UW2	76	75
06UW3	88	88
06UW4	101	101

DRIVE SIZE	Inline Drive	
	Base	Flange
07UW2	163	175
07UW3	179	190
07UW4	185	196
07UW5	194	205
08UW2	258	280
08UW4	307	329
08UW5	298	320
09UW2	400	432
09UW4	457	490
09UW5	463	496
10UW2	635	693
10UW4	720	777
10UW5	677	735



866-REXNORD/866-739-6673 (Within the US)
414-643-2366 (Outside the US)
www.rexnord.com

Why Choose Rexnord?

When it comes to providing highly engineered products that improve productivity and efficiency for industrial applications worldwide, Rexnord is the most reliable in the industry. Commitment to customer satisfaction and superior value extend across every business function.

Delivering Lowest Total Cost of Ownership

The highest quality products are designed to help prevent equipment downtime and increase productivity and dependable operation.

Valuable Expertise

An extensive product offering is accompanied by global sales specialists, customer service and maintenance support teams, available anytime.

Solutions to Enhance Ease of Doing Business

Commitment to operational excellence ensures the right products at the right place at the right time.

Rexnord Corporation

Rexnord is a growth-oriented, multi-platform industrial company with leading market shares and highly trusted brands that serve a diverse array of global end markets.

Process and Motion Control

The Rexnord Process and Motion Control platform designs, manufactures, markets and services specified, highly engineered mechanical components used within complex systems where our customers' reliability requirements and the cost of failure or downtime are extremely high.

Water Management

The Rexnord Water Management platform designs, procures, manufactures and markets products that provide and enhance water quality, safety, flow control and conservation.

REXNORD

Rex® FALK Link-Belt® mar/bett® MCC BERG highfield Stearns®