

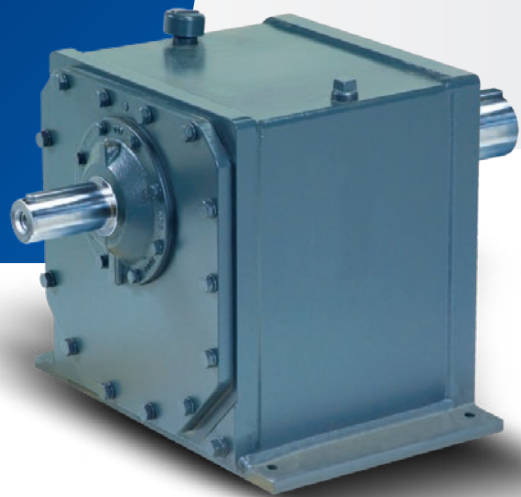

Falk™ UltraMax™
Concentric Gear Drives
IMPERIAL

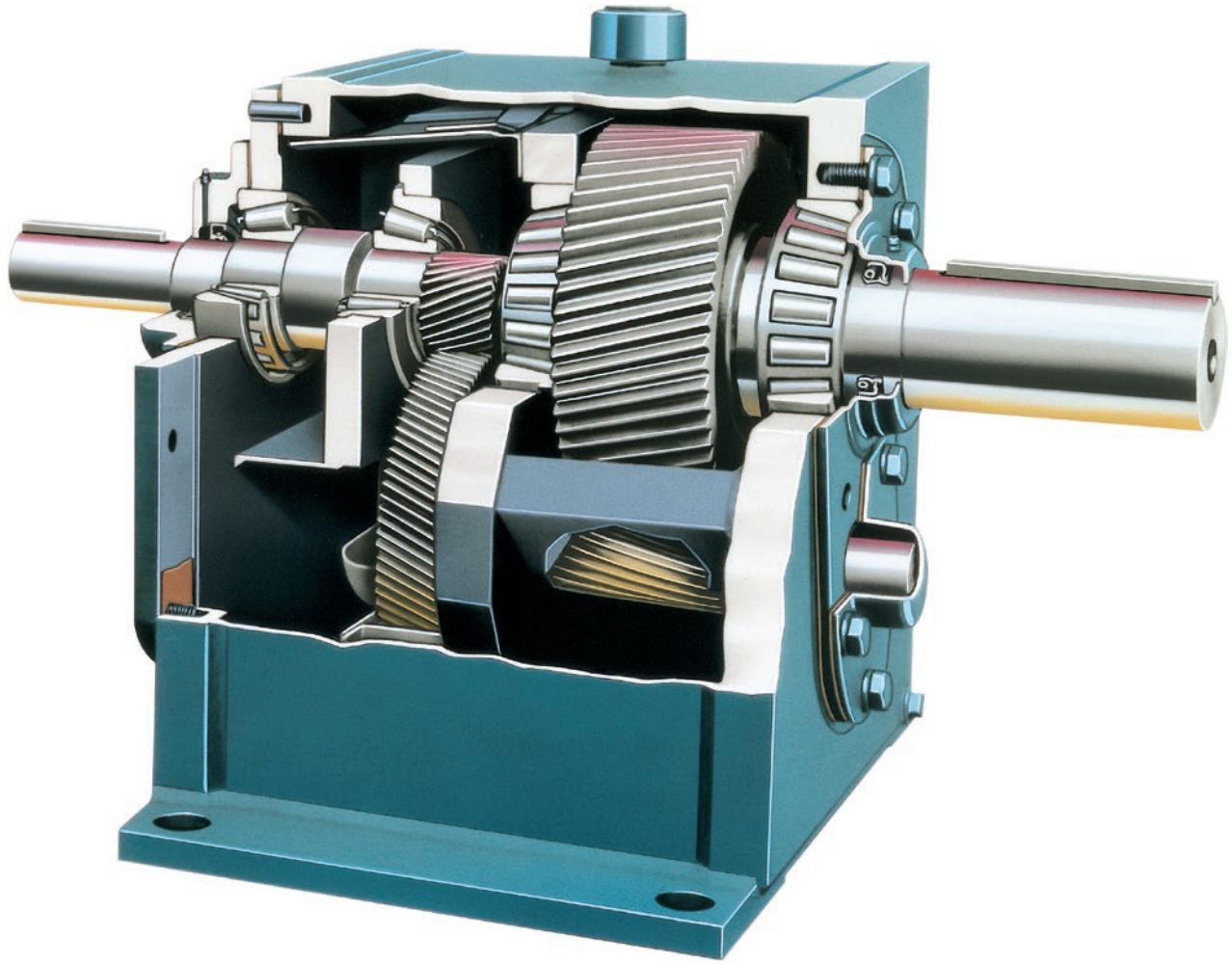

Falk™ UltraMax™ Concentric Gear Drive



To learn more about the Falk UltraMax Concentric Gear Drive,
go to regalrexnord.com, where you'll find:
Product information • Brochures • Catalogs • Manuals
Contact us at regalrexnord.com/contact



Table of Contents

DESCRIPTION	PAGE
Falk™ UltraMax™ Concentric Gear Drives Basic Information	4
Conditions Affecting Selection	5
Service Factors	7
Load Classification Factors	9
How to Select/Quick Selection Method	11
Drive Nomenclature	12
DRIVE SELECTION	
How to Order UltraMax™ Drives	13
Quick Selection Tables	14
How to Select/Horsepower & Torque Ratings Table Method	31
Horsepower & Torque Ratings	32
TECHNICAL DATA	
Thermal Horsepower	41
Basic Thermal Ratings	43
Cooling for UltraMax Drives	46
Overhung Loads	47
LSS Overhung Load Ratings	49
HSS Overhung Load Ratings	50
LSS Thrust Loads	54
Exact Ratios	55
Availability & Compatibility of Accessories	56
DIMENSIONS AND ACCESSORIES	
Double, Triple & Quadruple Reduction Dimensions	57
Motor Mounts	62
Motor Adapters	64
Motor Plates	65
Slide Rails	66
Slide Bases	67
Backstops	68
Electric Fans	70
Cooling Tubes	71
Coupling Guards	74
Notes	75

Falk™ UltraMax™ Concentric Gear Drives Basic Information

Safety Notes

Falk Gear Drives — The Falk and Rexnord™ name on the gear drive is the purchaser's assurance that the drive was engineered, rated and manufactured to sound design practices.

When one prime mover drives two pieces of equipment, one of which is either a standard Falk/Rexnord geared drive or a customer standard geared drive, the division of power between each machine is the responsibility of the customer. The power supplied to the geared drive must be equal to or less than the power for which the drive was selected, using the appropriate service factor for the application. The customer must also assume the responsibility of isolating the geared drive from any vibratory or transient load induced by the driven equipment.

Install and operate Regal Rexnord™ products in conformance with applicable local and national safety codes and per Regal Rexnord installation manuals which are shipped with gear drives and are also available upon request. Suitable guards for rotating members may be purchased from Regal Rexnord as optional accessories. Consult your local Regal Rexnord representative for complete details.

People Conveying Equipment — Selection of Rexnord gear drives for applications whose primary purpose is the transportation of people is not approved. This includes such applications as freight or passenger elevators, escalators, man-lift platforms, and ski tows and ski lifts.

If the primary purpose of the application is material conveyance and occasionally people are transported, the Regal Rexnord warranty may remain in effect, provided the design and load conditions are not exceeded and certification to the appropriate safety codes and load conditions has been obtained by the system designer or end user from the appropriate enforcement authorities.

Gear Drive Ratings

All gear drive ratings in this catalog allow 100% overload for starting loads and momentary overloads for electric-motor-driven applications operating ten hours per day under uniform conditions (unity service factor). For other conditions, compute an equivalent power by multiplying the actual power required for the application by the appropriate service factor.

Gear Drive Identification — Tables in this catalog identify gear drives by size, type and ratio. See Drive Nomenclature **page 12**.

Horsepower & Torque — Gear drive mechanical horsepower and torque ratings are tabulated in the catalog to permit selections for specific application requirements. NOTE: Drives may be selected using the Quick Selection tables under most circumstances. Refer to those tables starting on **page 14** for selection guidelines.

Thermal Ratings must be considered when selecting a gear drive. Refer to **page 41** for more information.

Stored & Inactive Drives — Each gear drive is spin-tested with a rust preventive oil that will protect parts against rust for a period of four months in an outdoor shelter or 12 months in a dry building after shipment from the Factory.

Periodically inspect stored or inactive drives and spray internal parts with rust inhibitor every six months or more often, if necessary. Drain oil before adding rust inhibitor. Indoor dry storage is recommended.

Drives ordered for extended storage can be treated at the Factory with a special preservative and sealed to rust-proof parts for periods longer than those cited above, if specified on the order.

Refer to appropriate service manual for extended storage of gear drives which have been in service.



Factory Warranty — We're so confident in the performance and reliability of our latest generation of Falk gear drives that we're backing this comprehensive offering with the best standard warranty in the business. Our full, three-year heavy-duty warranty provides shaft-to-shaft protection on all Falk components — including bearings and seals (warranty extends for three years from date of shipment). It's an industry first and one more powerful reason why Falk is your ultimate bottom-line value.

See Extended Warranty statement (100-003) on our website: regalrexnord.com

Conditions Affecting Selection

Non-Standard Application Procedures

The following conditions may affect the UltraMax™ gear drive selection procedure, drive size and auxiliary equipment being furnished.

Excessive Overloads — The maximum momentary or starting load must not exceed 200% of rated load (100% overload). Rated load is defined as gear drive rating with a service factor of 1.0. If the maximum starting or momentary load exceeds the above conditions, compute a second equivalent power rating by dividing the peak load by two. The gear drive selected must have capacity equal to, or in excess of, the larger equivalent power rating.

Frequency of Starts — Starting frequency is an important consideration when selecting a gear drive. Applications involving 2 to 3 equally spaced starts per hour must utilize a minimum 1.5 service factor for unloaded starts, and a minimum 1.75 service factor for fully loaded starts. For applications involving more than 3 starts per hour, refer to Regal Rexnord the application specifics such as starting frequency and maximum starting torque. AC motors also have similar limitations. The addition of a fluid coupling as a soft start device would increase the number of allowable starts.

Reversing Service — Applications involving either more than 20 reversals per ten hour period, or less than 20 reversals per ten hour period with peak torques greater than 200% of normal load must be referred to the Factory.

Brake-Equipped Applications — When a gear drive is equipped with a “working” brake that is used to decelerate the motion of the system and the brake is located between the prime mover and the gear drive, select the drive based on the brake rating or the highest equivalent power rating, whichever is greater. If the brake is used for holding only and is applied after the motion of the system has come to rest, the brake rating must be less than 200% of the catalog rating. Refer the application to the Factory. Also refer to the Factory all applications in which the brake is located on the output shaft of the gear drive.

Oversized Prime Mover — Published service factors do not cover applications that require oversized prime movers for high-energy or peak loads. Refer such applications to the Factory for selection of suitable drives.

Speed Variation or Multi-Speed Applications — Type FC and FZ gear drives offered in this catalog are designed to operate with splash lubrication on any single-speed application and any ratio shown in the catalog unless otherwise noted. It is essential that all orders indicate the desired operating speed and ratio so that the proper internal oil distribution accessories can be supplied for the specific speed.

These drives are assembled with a variety of standard internal lubrication components such as oil pans and oil deflectors to ensure proper splash lubrication. In addition, different oil levels are necessary for various drive sizes, speeds and ratios. Consequently, to operate an existing drive at different speeds from those shown on the nameplate, full application and nameplate information must be referred to the Factory for review of the lubrication system.

All variable or multi-speed applications will be referred to the Engineering Department to specify lubrication components for adequate lubrication at the slowest speed, without excessive heating or churning at the highest speed. It is essential that all orders indicate minimum and maximum speeds, as well as the speed duration cycles.

When selecting gear drives for multi-speed or variable speed applications, determine the speed which develops the greatest torque and select the drive on this basis. If the speed is not listed in the selection table, use the next lower speed.

Application-Adjusted Thermal Rating, page 41 — The Application-Adjusted Thermal Rating is the actual power rating without service factor that a gear drive will transmit continually for three hours or more without overheating. The Application-Adjusted Thermal Rating considers the environmental factors of the application which will affect the ability of the drive to dissipate heat. These factors include ambient temperature, air movement, altitude (thin air does not remove heat effectively), inlet water temperature and duty cycle (percentage of an hour that the drive operates). Factors for these conditions must be used to modify the Basic Thermal Rating when determining the Application-Adjusted Thermal Rating.

Checking the thermal rating is extremely important, for if a gear drive creates heat faster than it can be dissipated, severe damage may occur.

Thermal ratings need not be considered when the operating period does not exceed three hours and the shutdown time equals or exceeds the running time. However, when the running time exceeds the shutdown time, selection must be made on the basis of adequate thermal rating using the Application-Adjusted Thermal Rating.

Effects of Solar Energy — If a drive operates in the sun at ambient temperatures over 100°F (38°C), then special measures must be taken to protect the drive from solar energy. This protection can consist of a canopy over the drive or reflective paint on the drive. If neither is possible, additional cooling may be required, such as shaft fans, electric fans, cooling tubes or heat exchangers.

Overhung Loads & Thrust Loads — The overhung load and thrust load ratings published in this catalog are based on a service factor of unity and a combination of the most unfavorable conditions of rotation, speed, direction of applied load and drive loading. If the calculated load exceeds the published value, or if an overhung load and thrust load are applied simultaneously to a shaft, refer to tables and guidelines on pages 47-54.

Product Modifications — Regal Rexnord can supply special product modifications to suit your application needs. Contact your local Regal Rexnord™ representative for housing modifications, special ratios, special shafts, special mounting conditions, accessory modifications and other special application requirements.

Conditions Affecting Selection

Non-Standard Motors

Factory approval is required for motors and motor positions that vary from those shown in this catalog. Motor brackets are designed to suit the standard Type T10 Steelflex™ couplings furnished with the drives and current standard 1750 rpm, single-speed, A-C, NEMA, T & U series motor frames. Use of oversize motors, the extending or modifying of motor brackets, addition of clutches, brakes, etc., require Factory approval. Normally, motor plates are recommended for these applications.

Mounting Positions

UltraMax drives can be modified to permit mounting in positions other than conventional floor mounting. Some of these include ceiling, wall and various inclined vertical and tilted positions. Consult the Factory to determine what modifications are required for your specific application.

Motor Brackets

Motor brackets provide an economical option for mounting electric motors to gear drives. Due to the large variation in motor sizes/weights/starting torques/ & mounting positions (determined by coupling types), some motor bracket installations may deflect and vibrate beyond levels considered satisfactory to the end user.

When a motor bracket is purchased as the motor mounting structure, it becomes the customer's responsibility to support the motor bracket as necessary to diminish motor bracket deflection and vibration to satisfactory levels as determined by the end user. This may be accomplished with jacking screws or by adding other structural supports in the field.

Motor plates or special bedplates are recommended for applications subjected to high system vibration, torque fluctuations, impact loads, or other installations that require rigidly mounted machinery.

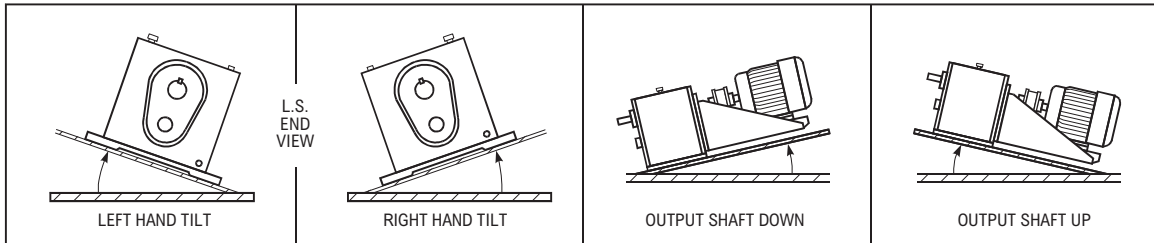

Maximum Standard Allowable Tilt & Incline Mounting Limits ①

Drive Size ①	Tilted ②						Inclined					
	Double Reduction		Triple Reduction		Quadruple Reduction		Double Reduction		Triple Reduction		Quadruple Reduction	
	Left-Hand	Right-Hand	Left-Hand	Right-Hand	Left-Hand	Right-Hand	L.S. Shaft Down	L.S. Shaft Up	L.S. Shaft Down	L.S. Shaft Up	L.S. Shaft Down	L.S. Shaft Up
2040	5°	5°	5°	5°	—	—	5°	10°	5°	10°	—	—
2050	2°	5°	2°	5°	10°	5°	2°	10°	2°	10°	2°	10°
2060	5°	5°	5°	5°	5°	5°	5°	2°	2°	2°	2°	2°
2070	5°	5°	5°	5°	5°	5°	5°	2°	2°	2°	2°	2°
2080	5°	5°	5°	5°	5°	5°	5°	2°	5°	2°	2°	2°
2090	5°	5°	5°	5°	5°	5°	5°	2°	5°	2°	5°	2°
2100	5°	5°	5°	5°	5°	5°	5°	2°	5°	2°	5°	2°
2110	5°	5°	5°	5°	5°	5°	5°	2°	5°	2°	5°	2°
2120	5°	5°	5°	5°	5°	5°	5°	2°	5°	2°	5°	2°
2130	5°	5°	5°	5°	5°	5°	5°	2°	5°	2°	5°	2°

① Maximum limits shown above apply to standard Type FC/FZ drives without modification. For applications requiring higher tilt or incline angles, refer to Factory. Oil level must be checked when drive is in the tilted or inclined position.

② Size 2060-2130 drives: dipstick must be located on high side of drive as shown in picture.

Service Factors

Table 1 — Class/Service Factor Conversion Table

Class	Service Factor
I	1.00
II	1.41
III	2.00

Service Factors

UltraMax™ drives may be selected by Service Factor or Load Classification. Selections may vary, so compare Service Factor against Load Classification on page 9 or page 10. Selecting the lowest Service Factor from Table 1 will result in the most economical selection.

A gear drive is rated to a specific application by the use of Service Factor. Each application has its conditions and operating requirements. These have been analyzed and cataloged. Numerical values, based on field experience, have been assigned to these classifications for intermittent service of 3 to 10 hours per day and for service over 10 hours per day and also for the type of prime mover, electric motor or engine. Values for most applications are listed by application on page 8, Table 4 and by industry at right, Table 3. Refer unlisted applications to the Factory.

Since most industrial applications are electric-motor-driven, Service Factors are based on the use of electric motors. These factors can be easily converted to engine-drive factors as outlined in Table 2.

Service Factors are based on the assumption that the system is free of dynamic vibrations, as explained in the Basic Information section, and that maximum momentary or starting loads do not exceed 200% of the rated load. Refer applications subject to repetitive shocks and applications where exceedingly high-energy load must be absorbed, as when stalling, to the Factory for special considerations.

Occasional & Intermittent Service or Engine-Driven Applications

Engine-driven applications and applications operating up to 3 hours per day, continuously or intermittently, require adjusted Service Factors. Determine normal Service Factor for the application from the 3 to 10 hours per day column in Table 3 or Table 4. Next, in the first column of Table 2 below, find this same Service Factor. Then, to the right, under the desired hours of service and prime mover, locate the converted Service Factor.

For example, from Table 4, the Service Factor is 1.25 for a uniformly-loaded belt conveyor. From Table 1, for the same application the following are the Service Factors for various conditions.

1. Engine-driven (multi-cylinder): 3 to 10 hours per day, use 1.50.
2. Engine-driven (multi-cylinder): over 10 hours per day, use 1.75.
3. Motor-driven (electric): up to 3 hours intermittently, use 1.00.

Table 2 — Service Factor Conversions

Table 3 or Table 4 3 to 10 Hour Service Factor	3 to 10 Hours per Day		Intermittent — Up to 3 Hours per Day ①	
	Multi-Cyl. Engine ②	Over 10 Hours per Day	Motor	Multi-Cyl. Engine ②
1.00 (Class I)	1.25	1.50	1.00	1.00
1.25	1.50	1.75	1.00	1.25
1.41 (Class II)	1.75	2.00	1.25	1.50
1.50	1.75	2.00	1.25	1.50
1.75	2.00	2.25	1.50	1.75
2.00 (Class III)	2.25	2.50	1.75	2.00

- ① For applications operating one half hour or less per day and applications driven by single-cylinder engines, refer to Factory.
- ② These service factors are based on the assumption that the system is free from serious critical and torsional vibrations and that maximum momentary or starting loads do not exceed 200% of the normal load.
- ③ Service factors for paper mill applications are applied to the nameplate rating of the electric drive motor at the motor-rated base speed and are consistent with those shown in TAPPI standards.
- ④ Anti-friction bearings only.
- ⑤ A service factor of 1.00 may be applied at base speed of a super calender operating over a speed range of part constant hp and part constant torque, where the constant hp speed range is greater than 1.5 to 1. A service factor of 1.25 is applicable to super calenders operating at constant torque over the entire speed range or where the constant hp speed range is less than 1.5 to 1.

Table 3 — Service Factors Listed by Industry

(For electric motor, steam turbine or hydraulic motor drives, recommendations are MINIMUM and normal conditions are assumed.)

Industry	Service		Industry	Service	
	3 to 10 Hour	Over 10 Hour		3 to 10 Hour	Over 10 Hour
BOTTLING AND BREWING					
Bottling Machinery.....	1.00	1.25	Embosser.....	—	1.25
Brew Kettles, Continuous Duty.....	1.25	1.25	Extruder.....	—	1.50
Can Filling Machines.....	1.00	1.25	Fourdrinier Rolls — Lumpbreaker, Wire Turning, Dandy & Return Rolls.....	—	1.25
Cookers — Continuous Duty.....	1.25	1.25	Jordan.....	—	1.50
Mash Tubs — Continuous Duty.....	1.25	1.25	Kiln Drive.....	—	1.50
Scale Hoppers — Frequent Starts.....	1.25	1.50	Mt. Hope & Paper Rolls.....	—	1.25
CLAY WORKING INDUSTRY					
Brick Press.....	1.75	2.00	Platter.....	—	1.50
Briquette Machines.....	1.75	2.00	Presses (Felt & Suction).....	—	1.25
Clay Working Machinery.....	1.25	1.50	Pulper (Continuous).....	—	2.00
Pug Mills.....	1.25	1.50	Repulper (Heavy Shock).....	—	2.00
DISTILLING DREDGES					
Cable Reels, Conveyors.....	1.25	1.50	Reel (Surface Type).....	—	1.25
Cutter Head, Jig Drives & Pumps.....	2.00	2.00	Screens.....	—	1.50
Maneuvering Winches.....	1.75	2.00	Chip & Rotary.....	—	1.50
Screen Drives.....	1.75	2.00	Vibrating.....	—	2.00
Stackers, Utility Winches.....	1.25	1.50	Size Press.....	—	1.25
FOOD INDUSTRY					
Beet Slicers.....	1.25	1.50	Super Calenders ④.....	—	1.25
Bottling, Can Filling Machine.....	1.00	1.25	Thickener & Washer.....	—	1.50
Cereal Cookers.....	1.00	1.25	AC Motor.....	—	1.25
Dough Mixers, Meal Grinders.....	1.25	1.50	DC Motor.....	—	1.25
LUMBER INDUSTRY					
Barkers — Spindle Feed.....	1.25	1.50	Vacuum Pumps.....	—	1.50
Barkers — Main Drive.....	1.75	1.75	Wind & Unwind Stand.....	—	1.25
Carriage Drive.....	Refer to Factory		Winders (Surface Type).....	—	1.25
Chains — Floor.....	1.50	1.50	④ Yankee Dryers.....	—	1.25
Chains — Green.....	1.50	1.75	PLASTIC INDUSTRY		
Conveyors.....			Batch Drop Mill, 2 smooth rolls.....	1.25	1.25
Burner.....	1.25	1.50	Calenders.....	1.50	1.50
Main or Heavy-Duty.....	1.50	1.50	Compounding Mills.....	1.25	1.25
Main Log.....	1.75	2.00	Continuous Feed, Holding & Blend Mill.....	1.25	1.25
Re-Saw Merry-Go-Round.....	1.25	1.50	Extruders.....	1.50	1.50
Slab.....	1.75	2.00	Variable Speed Drive.....	1.50	1.50
Transfer.....	1.25	1.50	Fixed Speed Drive.....	1.75	1.75
Cut-Off Saws — Chain & Drag.....	1.50	1.75	Intensive Internal Mixers		
Debarking Drums.....	1.75	2.00	Batch Mixers.....	1.75	1.75
Feeds — Edger.....	1.25	1.50	Continuous Mixers.....	1.50	1.50
Feeds — Gang.....	1.75	1.75	RUBBER INDUSTRY		
Feeds — Trimmer.....	1.25	1.50	Batch Drop Mill, 2 smooth rolls.....	1.50	1.50
Log Deck.....	1.75	1.75	Calenders.....	1.50	1.50
Log Hauls — Incline, Well Type.....	1.75	1.75	Cracker, 2 corrugated rolls.....	2.00	2.00
Log Turning Devices.....	1.75	1.75	Cracker Warmer — 2 roll, 1 corrugated roll.....	1.75	1.75
Planer Feed.....	1.25	1.50	Extruders.....		
Planer Tilting Hoists.....	1.50	1.50	Continuous Screw Operation.....	1.75	1.75
Rolls—Live-Off Bearing—Roll Cases.....	1.75	1.75	Intermittent Screw Operation.....	1.75	1.75
Sorting Table, Tipple Hoist.....	1.25	1.50	Holding, Feed & Blend Mill—2 Roll.....	1.25	1.25
Transfers — Chain & Craneway.....	1.50	1.75	Intensive Internal Mixers		
Tray Drives.....	1.25	1.50	Batch Mixers.....	1.75	1.75
Veneer Lathe Drives.....	Refer to Factory		Continuous Mixers.....	1.50	1.50
OIL INDUSTRY					
Chillers.....	1.25	1.50	Mixing Mill — 2 smooth rolls (if corrugated rolls are used, use Cracker Warmer service factors).....		
Oil Well Pumping.....	Refer to Factory		Refiner — 2 roll.....	1.50	1.50
Paraffin Filter Press.....	1.25	1.50	SEWAGE DISPOSAL		
Rotary Kilns.....	1.25	1.50	Bar Screens.....	1.25	1.25
PAPER MILLS ③					
Agitator (Mixer).....	—	1.50	Chemical Feeders.....	1.25	1.25
Agitator for Pure Liquids.....	—	1.25	Collectors.....	1.25	1.25
Barking Drums, Barkers — Mech.....	—	2.00	Dewatering Screens.....	1.50	1.50
Beater.....	—	1.50	Scum Breakers.....	1.50	1.50
Breaker Stack.....	—	1.25	Slow or Rapid Mixers.....	1.50	1.50
④ Calender.....	—	1.25	Thickeners.....	1.50	1.50
Chipper.....	—	2.00	Vacuum Filters.....	1.50	1.50
Chip Feeder.....	—	1.50	SUGAR INDUSTRY		
Coating Rolls.....	—	1.25	Cane Knives, Crushers.....	—	1.75
Conveyors —			Mills (low-speed end).....	1.75	1.75
Chip, Bark, Chemical.....	—	1.25	TEXTILE INDUSTRY		
Log (incl. Slab).....	—	2.00	Batchers, Calenders.....	1.25	1.50
Couch Rolls.....	—	1.25	Card Machines.....	1.25	1.50
Cutter.....	—	2.00	Dry Cans, Dryers.....	1.25	1.50
Cylinder Molds.....	—	1.25	Dyeing Machinery.....	1.25	1.50
④ Dryers —			Knitting Machinery.....	Refer to Factory	
Paper Mach. & Conveyor Type.....	—	1.25	Looms, Mangles, Nappers, Pads.....	1.25	1.50
			Range Drives.....	Refer to Factory	
			Slashers, Soapers, Spinners, Tenter Frames, Washers, Winders.....	1.25	1.50
			WINDLASS Refer to Factory		

Service Factors

Table 4 — Service Factors Listed by Application

(For electric motor, steam turbine or hydraulic motor drives, recommendations are MINIMUM and normal conditions are assumed.)

Application	Service		Application	Service		Application	Service		Application	Service	
	3 to 10 Hour	Over 10 Hour		3 to 10 Hour	Over 10 Hour		3 to 10 Hour	Over 10 Hour		3 to 10 Hour	Over 10 Hour
AGITATORS			ⓐ CONVEYORS — Uniformly-Loaded or Fed			ⓐ HOISTS			PUMPS		
Pure Liquids.....	1.00 ⓐ	1.25 ⓐ	Apron, Bucket.....	1.25	1.50	Heavy-Duty.....	1.75	2.00	Centrifugal.....	1.25	1.25
Liquids & Solids.....	1.25 ⓐ	1.50 ⓐ	Assembly, Belt, Chain, Flight, Oven, Screw.....	1.25	1.25	Medium Duty.....	1.25	1.50	Proportioning.....	1.25	1.50
Liquids — Variable Density.....	1.25 ⓐ	1.50 ⓐ				Skip Hoist.....	1.25	1.50	Reciprocating		
APRON CONVEYORS			ⓑ CONVEYORS — Heavy-Duty, Not Uniformly Fed			INDUCED DRAFT FANS	1.50	1.50	Single-Act., 3 or more Cyl.....	1.25	1.50
Uniformly-Loaded or Fed.....	1.25	1.50	Apron, Assembly, Belt, Bucket, Chain, Flight, Oven, Screw.....	1.25	1.50	See Mills, Rotary			Double-Act., 2 or more Cyl.....	1.25	1.50
Heavy-Duty.....	1.25	1.50				KILNS	1.50	1.50	Single-Act., 1 or 2 Cyl.....	Refer to Factory	
APRON FEEDERS	1.25	1.50	CONVEYORS — Severe Duty			LAUNDRY WASHERS	1.50	2.00	Double-Acting, 1 Cyl.....	Refer to Factory	
ASSEMBLY CONVEYORS			Live Roll.....	Refer to Factory		LAUNDRY TUMBLERS	1.25	1.50	Rotary: Gear, Lobe, Vane.....	1.00	1.25
Uniformly-Loaded or Fed.....	1.25	1.50	Reciprocating Shaker.....	1.75	2.00	LINE SHAFTS			PUNCH PRESSES		
Heavy-Duty.....	1.25	1.50	COOKERS (Brewing & Distilling), (Food)	1.25	1.25	Driving Processing Equipment.....	1.25	1.50	(Gear-Driven).....	1.75	2.00
BALL MILLS	See Mills, Rotary	2.00	COOLING TOWER FANS	Refer to Factory		Other Line Shafts, Light.....	1.00	1.25	RECIPROCATING		
BARGE HAUL PULLERS	1.75	2.00	ⓐ CRANES			LIVE ROLL CONVEYORS	Refer to Factory		Conveyors & Feeders.....	1.75	2.00
BARKING			Dry Dock Cranes, Main Hoist, Bridge and Trolley Travel.....	Refer to Factory		LOBE BLOWERS OR COMPRESSORS	1.25	1.50	RECIPROCATING COMPRESSORS		
Drums (Coupling-Connected).....	—	2.00	CRUSHERS			Multi-Cylinder.....	1.50	1.75	Single-Cylinder.....	1.75	2.00
Mechanical.....	—	2.00	Ore or Stone.....	1.75	2.00	ROD MILLS	See Mills, Rotary		ROTARY		
BAR SCREENS (Sewage)	1.25	1.25	Sugar.....	—	1.75	Pumps.....	1.00	1.25	Pumps.....	1.00	1.25
BATCHERS (Textile)	1.25	1.50	DEWATERING SCREENS (Sewage)	1.50	1.50	Screens (Sand or Gravel).....	1.25	1.50	RUBBER & PLASTICS INDUSTRIES	See Table 3	
BELT CONVEYORS			DISC FEEDERS	1.00	1.25	SAND MULLERS	1.25	1.50	SCREENS		
Uniformly-Loaded or Fed.....	1.25	1.25	DISTILLING	See Table 3		Air Washing.....	1.00	1.25	Air Washing.....	1.00	1.25
Heavy-Duty.....	1.25	1.50	DOUBLE-ACTING PUMPS			Rotary — Sand or Gravel.....	1.25	1.50	Traveling Water Intake.....	1.00	1.25
BELT FEEDERS	1.25	1.50	2 or more Cylinders.....	1.25	1.50	Traveling Water Intake.....	1.00	1.25	SCREW CONVEYORS		
BENDING ROLLS (Machine)	1.25	1.50	Single-Cylinder.....	Refer to Factory		Uniform.....	1.25	1.25	Heavy-Duty or Feeder.....	1.25	1.50
BLOWERS			DOUGH MIXER (Food)	1.25	1.50	Heavy-Duty or Feeder.....	1.25	1.50	SCUM BREAKERS (Sewage)	1.50	1.50
Centrifugal.....	1.25	1.25	DRAW BENCH (Metal Mills)			SEWAGE DISPOSAL	See Table 3		SHAKER CONVEYORS	1.75	2.00
Lobe.....	1.25	1.50	Carriage & Main Drive.....	1.25	1.50	SHETTERS (Rubber)	—	1.50	SINGLE-ACTING PUMP		
Vane.....	1.25	1.25	DREDGES	See Table 3		SINGLE-ACTING PUMP			1 or 2 Cylinders.....	Refer to Factory	
BOTTLING MACHINERY	1.00	1.25	DRY DOCK CRANES	Refer to Factory		3 or more Cylinders.....	1.25	1.50	ⓐ SKI TOWS & LIFTS	Not Approved	
BREWING	See Table 3		DRYERS & COOLERS (Mills, Rotary)	—	1.50	ⓐ SKIP HOIST	1.25	1.50	SLAB PUSHERS	1.50	1.50
BRICK PRESS (Clay Working)	1.75	2.00	DYEING MACHINERY (Textile)	1.25	1.50	SLITTERS (Metal)	1.25	1.50	SLITTERS (Metal)	1.25	1.50
BRIQUETTE MACHINES (Clay Working)	1.75	2.00	ELEVATORS			SLUDGE COLLECTORS (Sewage)	1.25	1.25	SOAPERS (Textile)	1.25	1.50
BUCKET			Bucket-Uniform Load.....	1.25	1.50	SOAPERS (Textile)	1.25	1.50	SPINNERS (Textile)	1.25	1.50
Conveyors Uniform.....	1.25	1.50	Bucket-Heavy-Duty.....	1.25	1.50	STEERING GEARS	Refer to Factory		STOKERS	1.00	1.25
Conveyors Heavy-Duty.....	1.25	1.50	Bucket-Continuous.....	1.25	1.50	STONE CRUSHERS	1.75	2.00	STONE CRUSHERS	1.75	2.00
Elevators Continuous.....	1.25	1.50	Centrifugal Discharge.....	1.25	1.25	SUGAR INDUSTRY	See Table 3		SUGAR INDUSTRY	See Table 3	
Elevators Uniform.....	1.25	1.50	ⓐ Escalators.....	Not Approved		TABLE CONVEYORS, Non-Reversing			TABLE CONVEYORS (Non-Reversing)		
Elevators Heavy-Duty.....	1.25	1.50	ⓑ Freight.....	Not Approved		Group Drives.....	1.50	1.50	Concrete, Cont. & Int.....	1.25	1.50
CALENDERS			ⓐ Gravity Discharge.....	1.00	1.25	Non-Reversing Individual Drives.....	2.00	2.00	Individual Drives.....	2.00	2.00
Rubber and Plastic.....	See Table 3		ⓑ Man Lifts, Passenger.....	Not Approved		Reversing.....	1.50	1.50	Reversing.....	Refer to Factory	
Textile.....	1.25	1.50	EXTRUDERS (Plastic & Rubber)	See Table 3		Wire Drawing & Flattening Machines.....	1.25	1.50	TENTER FRAMES (Textile)	1.25	1.50
CANE KNIVES	—	1.75	FANS			Wire Winding Machines.....	1.50	1.50	TEXTILE INDUSTRY	See Table 3	
CAN FILLING MACHINES	1.00	1.25	Centrifugal.....	1.25	1.25	MILLS, ROTARY			THICKENERS (Sewage)	1.50	1.50
CARD MACHINES (Textile)	1.25	1.50	Cooling Towers.....	Refer to Factory		Ball and Rod Mills			TUMBLING BARRELS	1.75	2.00
CAR DUMPERS	1.75	2.00	Forced Draft.....	—	1.25	with Spur Ring Gear.....	—	2.00	VACUUM FILTERS (Sewage)	1.50	1.50
CAR PULLERS	1.25	1.50	Induced Draft.....	1.50	1.50	with Helical Ring Gear.....	—	1.50	VANE BLOWERS	1.25	1.50
CEMENT KILNS	See Mills, Rotary		Large (Mine, etc.).....	1.50	1.50	Direct-Connected.....	—	2.00	WINCHES (Dredges)	1.25	1.50
CENTRIFUGAL			Large Industrial.....	1.50	1.50	Cement Kilns, Dryers & Coolers, Pebble, Plain & Wedge Bar Mills.....	—	1.50	WINDERS (Textile)	1.25	1.50
Blowers, Compressors, Discharge Elevators, Fans or Pumps.....	1.25	1.25	Light (Small Diameter).....	1.00	1.25	Tumbling Barrels.....	1.75	2.00	WINDLASS	Refer to Factory	
CHAIN CONVEYORS			FEEDERS			MIXER (Also see Agitators)			WIRE		
Uniformly-Loaded or Fed.....	1.25	1.25	Apron, Belt.....	1.25	1.50	Concrete, Cont. & Int.....	1.25	1.50	Drawing Machines.....	1.25	1.50
Heavy-Duty.....	1.25	1.50	Disc.....	1.00	1.25	Constani Density.....	1.25	1.50	Winding Machines.....	1.50	1.50
CHEMICAL FEEDERS (Sewage)	1.25	1.25	Reciprocating.....	1.75	2.00	Variable Density.....	1.25	1.50			
CLARIFIERS	1.00	1.25	Screw.....	1.25	1.50	NAPPERS (Textile)	1.25	1.50			
CLASSIFIERS	1.25	1.50	FLIGHT CONVEYORS			OIL INDUSTRY	See Table 3				
CLAY WORKING	See Table 3		Uniform.....	1.25	1.25	ORE CRUSHERS	1.75	2.00			
COLLECTORS (Sewage)	1.25	1.25	Heavy.....	1.25	1.50	OVEN CONVEYORS					
COMPRESSORS			FOOD INDUSTRY	See Table 3		Uniform.....	1.25	1.25			
Centrifugal.....	1.25	1.25	GENERATORS (Not Welding)	1.00	1.25	Heavy-Duty.....	1.25	1.50			
Lobe.....	1.25	1.50	GRAVITY DISCHARGE ELEVATORS	1.00	1.25	PAPER MILLS	See Table 3				
Reciprocating			HAMMER MILLS	1.75	2.00	ⓐ PASSENGER ELEVATORS	Not Approved				
Multi-Cylinder.....	1.50	1.75				PEBBLE MILLS	—	1.50			
Single-Cylinder.....	1.75	2.00				PLATE PLANERS	1.75	2.00			
CONCRETE MIXERS						PRINTING PRESSES	Refer to Factory				
Continuous.....	1.25	1.50				PROPORTIONING PUMPS	1.25	1.50			
Intermittent.....	1.25	1.50				PUG MILLS (Clay)	1.25	1.50			
						PULLERS (Barge Haul)	1.75	2.00			

ⓐ Selection of Regal Rexnord™ products for applications whose primary purpose is the transportation of people is not approved. This includes such applications as freight or passenger elevators, escalators, man lifts, work lift platforms and ski lifts. If the primary purpose of the application is material conveyance and occasionally people are transported, the Factory warranty may remain in effect provided the design load conditions are not exceeded and certification to the appropriate safety codes and load conditions has been obtained by the system designer or end user from the appropriate enforcement authorities.

ⓑ Contact Regal Rexnord for proper selection of a Falk™ RAM mixer drive.

Load Classification Factors

Table 5 — Class/Service Factor Conversion Table

Class	Service Factor
I	1.00
II	1.41
III	2.00

Load Classification Factors

UltraMax™ drives may be selected by Service Factor or Load Classification. Selections may vary, so compare Load Classification against Service Factor on page 7 or page 8. Selecting the lowest Service Factor from Table 5 will result in the most economical selection.

A drive is rated to a specific application by the use of Load Classification Factors. Each application has its own conditions and operating requirements. These have been analyzed and cataloged. Numerical values, based on field experience, have been assigned to these classifications for intermittent service of 3 to 10 hours per day and for service over 10 hours per day and also for the type of prime mover, electric motor or engine. Values for most applications are listed by application on page 10, Table 7 and by industry at right, Table 6. Refer unlisted applications to the Factory.

Since most industrial applications are electric-motor-driven, Load Classification Factors are based on the use of electric motors. These factors can be easily converted to engine-drive factors as outlined in Table 2, page 7.

Load Classification Factors are based on the assumption that the system is free of dynamic vibrations, as explained in the Basic Information section, and that maximum momentary or starting loads do not exceed 200% of the rated load. Refer applications subject to repetitive shocks and applications where exceedingly high-energy load must be absorbed, as when stalling, to the Factory for special consideration.

Table 6 — Load Classification Factors Listed by Industry

(For electric motor, steam turbine or hydraulic motor drives, recommendations are MINIMUM and normal conditions are assumed.)

Industry	Service		Industry	Service	
	3 to 10 Hour	Over 10 Hour		3 to 10 Hour	Over 10 Hour
BREWING & DISTILLING			PAPER MILLS		
Bottling Machinery.....	I	II	Agitator (Mixer).....	II	II
Brew Kettles, Continuous Duty.....	—	II	Barker—Auxiliaries—Hyd.....	—	III
Can Filling Machines.....	I	II	Barker, Mechanical.....	—	III
Cookers — Continuous Duty.....	—	II	Barking Drum.....	—	III
Mash Tubs — Continuous Duty.....	—	II	Beater & Pulper.....	—	II
Scale Hoppers — Frequent Starts.....	II	II	Bleacher.....	—	II
CLAY WORKING INDUSTRY			ⓐ Calenders.....	—	II
Brick Press.....	III	III	ⓐ Calenders — Super.....	—	II
Briquette Machines.....	III	III	Converting Mach. — Except		
Clay Working Machinery.....	II	II	Cutters-Platers.....	—	II
Pug Mills.....	II	II	Conveyors.....	—	II
DISTILLING DREDGES			Couch.....	—	II
Cable Reels.....	II	—	Cutters, Platers.....	—	III
Conveyors.....	II	II	Cylinders.....	—	II
Cutter Head Drives.....	III	III	ⓐ Dryers.....	—	II
Jig Drives.....	III	III	Felt Stretchers.....	—	II
Maneuvering Winches.....	III	—	Felt Whippers.....	—	III
Pumps.....	III	III	Jordans.....	—	II
Screen Drives.....	III	III	Log Haul.....	—	III
Stackers.....	II	II	Presses.....	—	II
Utility Winches.....	II	—	Pulper (Continuous).....	—	III
FOOD INDUSTRY			Repulper (Heavy Shock).....	—	III
Beet Slicers.....	II	II	Stock Chests.....	—	II
Bottling, Can Filling Machine.....	I	II	Suction Rolls.....	—	II
Cereal Cookers.....	I	II	Washers & Thickeners.....	—	II
Dough Mixers, Meat Grinders.....	II	II	Winders.....	—	II
LUMBER INDUSTRY			RUBBER INDUSTRY		
Barkers — Spindle Feed.....	II	III	Mixer.....	III	III
Barkers — Main Drive.....	III	III	Rubber Calender.....	II	II
Carriage Drive.....	Refer to Factory		Rubber Mill (2 or more).....	II	II
Chains — Floor.....	II	III	Sheeter.....	II	II
Chains — Green.....	II	III	Tire Building Machines.....	Refer to Factory	
Conveyors			Tire, Tube Press Openers.....	Refer to Factory	
Burner.....	II	III	Tubers & Strainers.....	II	II
Main or Heavy-Duty.....	II	III	SEWAGE DISPOSAL		
Main Log.....	III	III	Aerators.....	Refer to Factory	
Re-Saw Merry-Go-Round.....	II	III	Bar Screens.....	II	II
Slab.....	III	III	Chemical Feeders.....	II	II
Transfer.....	II	III	Collectors.....	II	II
Cut-Off Saws — Chain & Drag.....	II	III	Dewatering Screens.....	II	II
Debarking Drums.....	III	III	Grit Collectors.....	II	II
Feeds — Edger.....	II	III	Scum Breakers.....	II	II
Feeds — Gang.....	III	III	Slow or Rapid Mixers.....	II	II
Feeds — Trimmer.....	II	III	Sludge Collectors.....	II	II
Log Deck.....	III	III	Thickeners.....	II	II
Log Hauls — Incline, Well Type.....	III	III	Vacuum Filters.....	II	II
Log Turning Devices.....	III	III	TEXTILE INDUSTRY		
Planer Feed.....	II	III	Batchers, Calenders.....	II	II
Planer Tilting Hoists.....	II	III	Card Machines.....	II	II
Rolls — Live — Off Bearing — Roll Cases.....	III	III	Cloth Finishing Machines, Calenders, Dryers, Pads, Tenters, Washers.....	II	II
Sorting Table, Tipple Hoist.....	II	III	Dry Cans.....	II	II
Transfers — Chain & Craneway.....	II	III	Dyeing Machinery.....	II	II
Tray Drives.....	II	III	Knitting Machinery.....	Refer to Factory	
OIL INDUSTRY			Looms, Mangles, Nappers.....	II	II
Chillers.....	II	II	Range Drives.....	Refer to Factory	
Oil Well Pumping.....	Refer to Factory		Soapers, Spinners.....	II	II
Paraffin Filter Press.....	II	II	Tenter Frames.....	II	II
Rotary Kilns.....	II	II	Winders.....	II	II
			Yarn Preparatory Machinery, (Cards, Spinners, Slashers).....	II	II

ⓐ Anti-friction bearings only.

Load Classification Factors

Table 7 — Load Classification Factors Listed by Application

(For electric motor, steam turbine or hydraulic motor drives, recommendations are MINIMUM and normal conditions are assumed.)

Application	Service		Application	Service		Application	Service		Application	Service	
	3 to 10 Hour	Over 10 Hour		3 to 10 Hour	Over 10 Hour		3 to 10 Hour	Over 10 Hour		3 to 10 Hour	Over 10 Hour
AERATORS	Refer to Factory		CONVERTING MACHINES (Paper) ...	—	II	GRIT COLLECTORS (Sewage).....	II	II	PUNCH PRESSES (Gear Driven).....	III	III
AGITATORS			ⓐ CONVEYORS—Uniformly-Loaded or Fed:			HAMMER MILLS.....	III	III	RECIPROCATING		
Paper Mills.....	II	II	Apron, Assembly, Belt, Bucket, Chain, Flight, Oven, Screw.....	II	II	INDUCED DRAFT FANS.....	II	II	Conveyors & Feeders.....	III	III
Pure Liquids.....	I ②	II ②	ⓑ CONVEYORS—Heavy-Duty, Not Uniformly Fed			Cement.....	Refer to Factory		RECIPROCATING COMPRESSORS		
Liquids & Solids.....	II ②	II ②	Apron, Assembly, Belt, Bucket, Chain, Flight, Oven, Screw.....	II	II	LAUNDRY WASHERS.....	II	III	Multi-Cylinder.....	II	III
Liquids — Variable Density.....	II ②	II ②	Live Roll (Package).....	II	II	LAUNDRY TUMBLERS.....	II	II	Single Cylinder.....	III	III
APRON CONVEYORS			Reciprocating, Shaker.....	III	III	LINE SHAFTS			ROD MILLS.....	III	III
Uniformly-Loaded or Fed.....	II	II	COOKERS (Brewing & Distilling), (Food).....			Heavy Shock Load.....	III	III	ROTARY		
Heavy-Duty.....	II	II	COOLING TOWER FANS.....	Refer to Factory		Moderate Shock Load.....	II	II	Pumps: Gear, Lobe, Vane.....	I	II
APRON FEEDERS.....	II	II	COUCH (Paper).....	—	II	Uniform Load.....	I	II	Screens (Sand or Gravel).....	II	II
ASSEMBLY CONVEYORS			ⓐ CRANES & HOISTS			LIVE ROLL CONVEYORS			RUBBER & PLASTICS INDUSTRIES	See Table 6	
Uniformly-Loaded or Fed.....	II	II	Main Hoists			Package.....	II	II	SAND MULLERS.....	Refer to Factory	
Heavy-Duty.....	II	II	Heavy-Duty.....	III	III	LOBE BLOWERS OR COMPRESSORS.....	II	II	SCREENS		
BALL MILLS.....	III	III	Medium Duty.....	II	II	LOG HAULS (Paper & Lumber).....	III	III	Air Washing.....	I	II
BARGE HAUL PULLERS.....	III	III	Reversing.....	II	II	LOOMS (Textile).....	II	II	Rotary — Sand or Gravel.....	II	II
BARKING			Skip Hoists.....	II	II	LUMBER INDUSTRY.....	See Table 6		Traveling Water Intake.....	I	II
Drums.....	—	III	Trolley Drive.....	II	II	MACHINE TOOLS			SCREW CONVEYORS		
Hydraulic Auxiliaries.....	—	III	Bridge Drive.....	II	II	Auxiliary Drives.....	I	II	Uniform.....	II	II
Mechanical.....	—	III	CRUSHERS			Bending Rolls.....	II	II	Heavy-Duty or Feeder.....	II	II
BAR SCREENS (Sewage).....	II	II	Ore or Stone.....	III	III	Main Drives.....	II	II	SCUM BREAKERS (Sewage).....	II	II
BATCHERS (Textile).....	II	II	CUTTERS (Paper).....	—	III	Notching Press (Belted).....	Refer to Factory		SEWAGE DISPOSAL.....	See Table 6	
BEATERS & PULPERS (Paper).....	—	II	CYLINDERS (Paper).....	—	II	Plate Planers.....	III	III	SHAKER CONVEYORS.....	III	III
BELT CONVEYORS			DEWATERING SCREENS (Sewage).....	II	II	Punch Press (Geared).....	III	III	SHEETERS (Rubber).....	II	II
Uniformly-Loaded or Fed.....	II	II	DISC FEEDERS.....	I	II	Tapping Machines.....	III	III	SINGLE-ACTING PUMP		
Heavy-Duty.....	II	II	DISTILLING.....	See Table 6		MANGLE (Textile).....	II	II	1 or 2 Cylinders.....	Refer to Factory	
BELT FEEDERS.....	II	II	DOUBLE-ACTING PUMPS			MASH TUBS (Brewing & Distilling).....	—	II	3 or more Cylinders.....	Not Approved	
BENDING ROLLS (Machine).....	II	II	2 or more Cylinders.....	II	II	MEAT GRINDERS (Food).....	II	II	SKI TOWS & LIFTS.....	Not Approved	
BLEACHERS (Paper).....	—	II	Single Cylinder.....	Refer to Factory		METAL MILLS			ⓐ SKIP HOIST.....	II	II
BLOWERS			DOUGH MIXER (Food).....	II	II	Draw Bench Carriages & Main Drives.....	III	III	SLAB PUSHERS.....	II	II
Centrifugal.....	II	II	DRAW BENCH (Metal Mills)			Forming Machines.....	III	III	SLITTERS (Metal).....	II	II
Lobe.....	II	II	Carriage & Main Drive.....	III	III	Pinch, Dryer & Scrubber Rolls, Reversing.....	Refer to Factory		SLUDGE COLLECTORS (Sewage).....	I	II
Vane.....	II	II	DREDGES.....	See Table 6		Slitters.....	II	II	SOAPERS (Textile).....	II	II
BOTTLING MACHINERY.....	I	II	DRYERS & COOLERS (Mills, Rotary).....	II	II	Table Conveyors			SPINNERS (Textile).....	II	II
BREWING.....	See Table 6		DYEING MACHINERY (Textile).....	II	II	Non-Reversing.....	III	III	STEERING GEARS.....	II	II
BRICK PRESS (Clay Working).....	III	III	ELEVATORS			Reversing.....	Refer to Factory		STOCK CHESTS (Paper).....	—	II
BRIQUETTE MACHINES (Clay Working).....	III	III	Bucket-Uniform Load.....	II	II	Wire Drawing & Flattening Machines.....	II	III	STOKERS.....	I	II
BUCKET			Bucket-Heavy-Duty.....	II	II	Wire Winding Machines.....	II	II	STONE CRUSHERS.....	III	III
Conveyors Uniform.....	II	II	Bucket-Continuous.....	II	II	MILLS, ROTARY			SUCTION ROLLS (Paper).....	—	II
Conveyors Heavy-Duty.....	II	II	Centrifugal Discharge.....	II	II	Ball, Pebble, Rod.....	III	III	TABLE CONVEYORS (Metal Mills)		
Elevators Continuous.....	II	II	Escalators.....	Not Approved		Cement Kilns.....	Refer to Factory		Non-Reversing.....	III	III
Elevators Uniform.....	II	II	Freight.....	Not Approved		Coolers, Dryers, Kilns.....	II	III	Reversing.....	Refer to Factory	
Elevators Heavy-Duty.....	II	II	Gravity Discharge.....	I	II	Tumbling Barrels.....	III	III	TENTER FRAMES (Textile).....	II	II
CALENDERS			Man Lifts, Passenger.....	Not Approved		MIXER (Also see Agitators)			TEXTILE INDUSTRY.....	See Table 6	
Rubber.....	II	II	FANS			Concrete — Continuous.....	II ②	II ②	THICKENERS (Sewage).....	II	II
Textile.....	II	II	Centrifugal.....	II	II	Concrete — Intermittent.....	II ②	—	TUMBLING BARRELS.....	III	III
CANE KNIVES.....	II	III	Escalators.....	Not Approved		Constant Density.....	II ②	II ②	VACUUM FILTERS (Sewage).....	II	II
CAN FILLING MACHINES.....	I	II	Freight.....	Not Approved		Variable Density.....	II ②	II ②	VANE BLOWERS.....	II	II
CARD MACHINES (Textile).....	II	II	Gravity Discharge.....	I	II	NAPPERS (Textile).....	II	II	WINCHES (Dredges).....	II	—
CAR DUMPERS.....	III	—	Man Lifts, Passenger.....	Not Approved		OIL INDUSTRY.....	See Table 6		WINDERS (Textile).....	—	II
CAR PULLERS.....	II	—	FANS			ORE CRUSHERS.....	III	III	Paper.....	—	II
CEMENT KILNS.....	Refer to Factory		Centrifugal.....	II	II	OVEN CONVEYORS			Textile.....	II	II
CENTRIFUGAL			Cooling Towers.....	Refer to Factory		Uniform.....	II	II	WINDLASS.....	Refer to Factory	
Blowers, Compressors, Discharge Elevators, Fans or Pumps.....	II	II	Forced Draft.....	II	II	Heavy-Duty.....	II	II	WIRE		
CHAIN CONVEYORS			Induced Draft.....	II	II	PAPER MILLS.....	See Table 6		Drawing Machines.....	II	III
Uniformly-Loaded or Fed.....	II	II	Large (Mine, etc.).....	II	II	PEBBLE MILLS.....	III	III	Winding Machines.....	II	II
Heavy-Duty.....	II	II	Large Industrial.....	II	II	PLATE PLANERS.....	III	III			
CHEMICAL FEEDERS (Sewage).....	I	II	Light (Small Diameter).....	I	II	PRESSES PAPER.....	—	II			
CLARIFIERS.....	I	II	FEEDERS			PROPORTIONING PUMPS.....	II	II			
CLASSIFIERS.....	I	II	Apron, Belt.....	II	II	PUG MILLS (Clay).....	II	—			
CLAY WORKING.....	See Table 6		Disc.....	I	II	PULLERS (Barge Haul).....	III	III			
COLLECTORS (Sewage).....	II	II	Reciprocating.....	III	III	PUMPS					
COMPRESSORS			Screw.....	II	II	Centrifugal.....	II	II			
Centrifugal.....	II	II	FELT			Proportioning.....	II	II			
Lobe.....	II	II	Stretchers (Paper).....	—	II	Reciprocating					
Reciprocating			Whippers (Paper).....	—	III	Single-Act., 3 or more Cyl.....	II	II			
Multi-Cylinder.....	II	III	FLIGHT CONVEYORS			Double-Act., 2 or more Cyl.....	II	II			
Single-Cylinder.....	III	III	Uniform.....	II	II	Single Act., 1 or 2 Cyl.....	Refer to Factory				
CONCRETE MIXERS			Heavy.....	II	II	Rotary: Gear, Lobe, Vane.....	I	II			
Continuous.....	II ②	II ②	FOOD INDUSTRY.....	See Table 6							
Intermittent.....	II ②	—	FORMING MACHINES (Metal Mills).....	III	III						
			GENERATORS (Not Welding).....	I	II						
			GRAVITY DISCHARGE ELEVATORS.....	I	II						

① Selection of Regal Rexnord™ products for applications whose primary purpose is the transportation of people is not approved. This includes such applications as freight or passenger elevators, escalators, man lifts, work lift platforms and ski tows and ski lifts. If the primary purpose of the application is material conveyance and occasionally people are transported, the Factory warranty may remain in effect provided the design load conditions are not exceeded and certification to the appropriate safety codes and load conditions has been obtained by the system designer or end user from the appropriate enforcement authorities.

② Contact Regal Rexnord for proper selection of a Falk™ RAM mixer drive.

How to Select/Quick Selection Method

Selection Information

This catalog contains two methods of selection. The Quick Selection Method and the Horsepower & Torque Ratings Table Method.

Before proceeding, determine which selection procedure to use. Use the Quick Selection Method if your application meets the following guidelines.

- 1750 rpm input
- Standard ratios for double, triple or quadruple reductions
- 80°F ambient at sea level (0 to 2500 ft.)

NOTE: If the above guidelines cannot be met, use the Horsepower & Torque Ratings Table Method, page 31. Also, if you have an unusual application involving any of the following conditions, refer to pages 5 and 6.

- Excessive Overloads
- Reversing Service
- Brake-Equipped Applications
- Oversized Prime Movers
- Multi-Speed or Variable Speed Applications
- Excessive Ambient Temperatures
- Thermal Rating Application Factors
- Excessive Overhung Loads or Thrust Loads
- Product Modifications
- Non-Standard Motors or Prime Movers
- Non-Standard Motor Bracket Applications
- Non-Horizontal Mounting Positions

How to Select by Quick Selection

1. Determine Service Factor or Load Classification Factor — See pages 7 and 8 or pages 9 and 10.
2. Determine Motor Horsepower.
3. Determine Drive Output Speed.
4. Select Drive Size — Use Quick Selection Tables, pages 14-30; find the table for your motor horsepower and locate the correct drive size opposite the nearest output rpm and the required service factor determined in Steps 1 thru 3.
5. Select Drive Configuration — Type FC or FZ, see pages 57-61.
6. Check Minimum Cooling Required — If a required cooling accessory is not acceptable, check a larger size drive.
7. Check Overhung Load — Minimum allowable sprocket pitch diameters are provided for the L.S. Shaft based on the sprocket being mounted one shaft diameter from the seal cage and a service factor of unity. Where overhung load is proportional to torque; e.g., pinion, sprocket or sheave applications, adjustment to the published values must be made based on the required service factor. The pitch diameter of the sprocket being used must not be less than the value (Pd) shown. If the sprocket is located at a distance other than one shaft diameter from the seal cage, refer to the instructions on page 47.
8. Check External Thrust Load — Thrust loads are provided on page 54. If thrust and overhung loads are applied simultaneously, or if loads exceed these capacities, consult the Factory.
9. Check Drive Dimensions — pages 57-61.
10. Place the Order — How to Order information on page 13.

Example

Application: Belt conveyor, heavy-duty, head shaft speed is 40 rpm, ambient temperature 100°F (38°C) at sea level.

Duty Cycle: 16 hours per day.

Driver: 50 hp electric motor, 1750 rpm.

Output: 11.3" pitch diameter sprocket with a 2:1 chain drive to the headshaft. Sprocket will be mounted 4.00" from drive seal cage.

1. Service factor from page 8 is 1.50.
2. Motor horsepower is 50 hp.
3. The head shaft speed must be multiplied by the chain drive ratio to obtain the drive output rpm (40 rpm x 2 = 80 rpm).
4. From page 24, in the 50 hp Quick Selection Table, the correct selection is a Size 2070F2, 20.54:1 exact ratio drive.

50 HP/1750 RPM/326T Motor

Approx. L.S. Shaft RPM	Drive Size & Reduction	Exact Ratio	HP Rating	Service Factor	Minimum Cooling Required	L.S. Shaft OHL Capacity (lb) ①	Minimum L.S. Shaft Sprocket Pitch Dia. ①
100	2060F_2	17.19	69.8	1.40	None	6500	9.69
100	2070F_2	17.33	102	2.04	None	8500	7.41
100	2080F_2	17.34	149	2.98	None	7480	8.42
84	2060F_2	21.13	59.3	1.19	None	6500	11.54
→ 84	2070F_2	20.54	84.8	1.70	None	8500	8.82
84	2080F_2	20.98	117	2.34	None	10200	7.35
68	2070F_2	25.12	68.0	1.36	None	8500	10.90
68	2080F_2	25.17	96.7	1.93	None	11000	8.42
56	2070F_2	31.08	53.1	1.06	None	8500	13.24

5. From page 61, the desired configuration is a Type FZ.
6. No cooling accessory is required.
7. Overhung load check — from the 50 hp Quick Selection Table, the minimum sprocket diameter is 8.82". This value is based on the sprocket being mounted one shaft diameter from the seal cage. Since the sprocket will be mounted 4.00" from the seal cage, refer to the Load Location Factor Table on page 48. Opposite the 4.00" and Size 2070, find the Load Location Factor for this distance. Multiply the allowable pitch diameter by the load location factor (8.82 x 1.13) to determine the actual minimum pitch diameter. The 11.3" sprocket diameter in the example exceeds the actual minimum allowable (9.97") and is therefore acceptable.
8. Check external thrust load capacity on page 54. For this example there is no external thrust.
9. Check dimensions on pages 57-61.
10. Place the order. How to Order information on page 13.

Drive Nomenclature

UltraMax™ drives in this catalog, product nameplates and customer orders are identified through the following nomenclature. Use the appropriate designations when placing an order or inquiring with a Regal Rexnord™ representative.

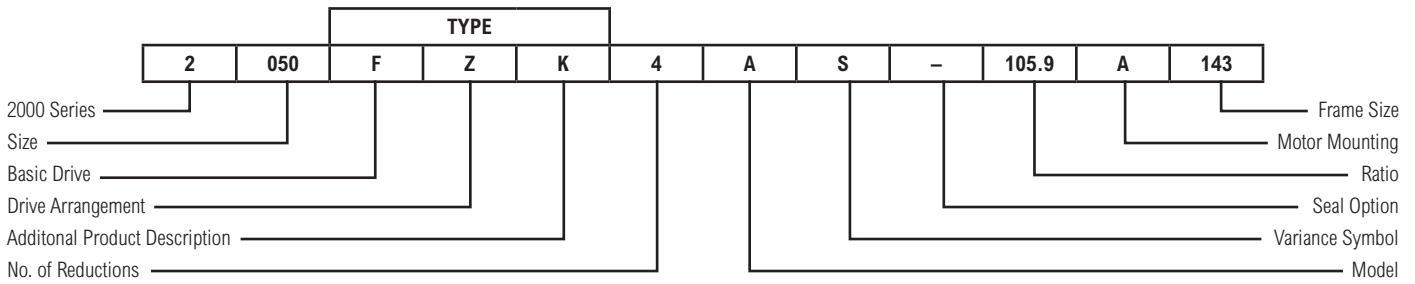

Size

- 2040 thru 2050 — Cast iron housings
- 2060 thru 2130 — Fabricated steel housings

Drive Arrangement

- C — Concentric Gear Drive
- Z — Concentric Gear Drive w/ motor bracket & input coupling
- M — Concentric Gear Drive w/ motor plate & input coupling
- A — Concentric Gear Drive w/ motor adapter
- D — Concentric Gear Drive w/ motor mount

Additional Product Description

- K — Torque rated basic drive

Reductions

- 2, 3, 4, etc.

Model

- A, B, C, etc.

Variance Symbol

- A — Drive w/ backstop
- B — Drive w/ shaft fan
- C — Drive w/ backstop & shaft fan
- D — Drive w/ electric fan
- E — Drive w/ electric fan & backstop
- F — Drive w/ cooling tubes
- G — Drive w/ cooling tubes & backstop
- H — Drive w/ pump & cooler (air)
- J — Drive w/ pump & cooler (air) & backstop
- K — Drive w/ pump & cooler (water)
- L — Drive w/ pump & cooler (water) & backstop
- S — Modified or special drive

Seal Option

- — Standard Nitrile seals
- V — Viton®* seals

Ratio

Exact ratio to four digits.

Motor Mounting

- A — NEMA Foot-Mounted motor, T Frame
- B — NEMA Foot-Mounted motor, TS Frame
- C — NEMA "C" Face motor, T Frame
- E — NEMA "C" Face motor, TS Frame
- G — IEC Foot-Mounted motor, Short (S) Frame
- H — IEC Foot-Mounted motor, Medium (M) Frame
- J — IEC Foot-Mounted motor, Long (L) Frame
- L — IEC B-5 ("D" flange) motor
- S — Special Motor/Motor Mounting; e.g., DC motor, Fluid Coupling

Frame Size

NEMA 042-500 or IEC 055-1080 (Note: 108 used for IEC 1080 frame).
NEMA motor frame is Falk™ standard.

* Viton is believed to be the trademark and/or trade name of The Chemours Company, FC, LLC, and is not owned or controlled by Regal Rexnord Corporation or its affiliates.

How to Order UltraMax™ Drives

The following information is required to quote or ship UltraMax drives to your requirements.

Drive

- A. Size and Type from selection tables.
- B. Ratio.
- C. Input and/or output speed (rpm).
- D. Horsepower — Motor or brake.
- E. Service Factor for application.
- F. Mounting position — Horizontal. See page 6 for tilt limits.
- G. Auxiliary equipment — Bed plate, couplings, backstop, etc.
- H. Thrust and overhung loads — Specify type and amount.

Motor — Prime Mover

- A. Type — Motor or engine.
- B. Horsepower.
- C. Speed — rpm.
- D. Frame size — Dimension prints if Regal Rexnord™ is to furnish mounting surface and/or mount the equipment.
- E. Motor — Weight, driver characteristics; e.g., enclosure, modifications and accessories, altitude, brake, etc.
- F. Furnished by: Regal Rexnord...Purchaser...
- G. Fitted by: Regal Rexnord...Purchaser...

Driven Machine

- A. Required horsepower or torque.
- B. Rpm.
- C. Application description — Belt conveyor, agitator, etc.
- D. Service — Duty cycle, hours per day, reversals per minute if reversing.
- E. Ambient temperature and operating conditions — Outdoor, taconite dust, etc.

Auxiliary Equipment

- A. Motors — If Regal Rexnord is to furnish, specify complete information, e.g. current characteristics, enclosure, modifications, accessories, etc.
- B. Couplings — Specify size, type, driver or driven hub bore and keyway size.
- C. Backstop — Specify direction of rotation of the low-speed shaft (clockwise or counterclockwise) when looking toward the drive from the low-speed end.
- D. Motor Mount — Specify complete motor information, required belt centers and mounting arrangement.
- E. Motor Plate — Specify complete motor, auxiliary equipment and coupling information.
- F. Electric Fan Position.
- G. Cooling Tube Water Inlet & Outlet Position.
- H. Coupling Guards — Furnish description of couplings or other equipment to be guarded and all dimensions A-G below.
- I. Motor Bracket — Specify complete motor information including motor weight, auxiliary equipment and coupling information.

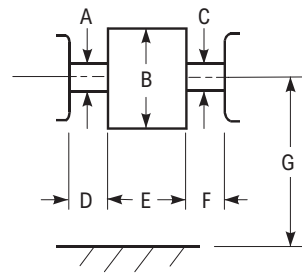

B & E...Max Cplg Dim
D & F...Exposed Shaft

Quick Selection Tables

1 HP/1750 RPM/143T Motor ①

Approx. L.S. Shaft RPM	Drive Size & Reduction	Exact Ratio	HP Rating	Service Factor	Minimum Cooling Required	L.S. Shaft OHL Capacity (lb) ②	Minimum L.S. Shaft Sprocket Pitch Dia (in) ②
11.0	2040F_3	159.4	2.50	2.50	None	3400	3.37
6.0	2050F_4	286.1	2.49	2.49	None	5250	4.00
5.0	2050F_4	343.3	2.08	2.08	None	5250	4.80
4.0	2050F_4	417.1	1.71	1.71	None	5250	6.00
4.0	2060F_4	449.4	2.80	2.80	None	6500	4.85
3.2	2050F_4	508.3	1.40	1.40	None	5250	7.50
3.2	2060F_4	543.0	2.32	2.32	None	6500	6.06
2.7	2060F_4	649.5	1.94	1.94	None	6500	7.18
2.7	2070F_4	641.4	2.81	2.81	None	8500	5.49
2.2	2060F_4	795.9	1.58	1.58	None	6500	8.81
2.2	2070F_4	785.9	2.29	2.29	None	8500	6.74
2.2	2080F_4	772.8	2.86	2.86	None	11000	5.21
1.8	2060F_4	965.5	1.30	1.30	None	6500	10.77
1.8	2070F_4	961.2	1.86	1.86	None	8500	8.24
1.8	2080F_4	927.2	2.25	2.25	None	11000	6.36

Motors are available from Regal Rexnord™ or Rexnord™ distributors.

1 HP/143T Motor

Energy Efficient Motor
Falk™ Part No. 2918104 TEFC, 1750 rpm 208-230/460 Volts, 3 Phase, 60 Hz, NEMA B, 1.15 Service Factor

Premium Efficiency Motor
Falk Part No. 2918124 TEFC, 1750 rpm 230/460 Volts, 3 Phase, 60 Hz, NEMA B, 1.15 Service Factor

Motors meeting other specifications are available upon request.

1.5 HP/1750 RPM/145T Motor ①

Approx. L.S. Shaft RPM	Drive Size & Reduction	Exact Ratio	HP Rating	Service Factor	Minimum Cooling Required	L.S. Shaft OHL Capacity (lb) ②	Minimum L.S. Shaft Sprocket Pitch Dia (in) ②
16.5	2040F_3	105.0	3.80	2.53	None	3400	3.37
13.5	2040F_3	125.0	3.16	2.11	None	3400	4.12
11.0	2040F_3	159.4	2.50	1.67	None	3400	5.05
9.0	2050F_4	187.5	3.53	2.35	None	5250	4.00
7.5	2050F_4	231.5	3.08	2.05	None	5250	4.80
6.0	2050F_4	286.1	2.49	1.66	None	5250	6.00
6.0	2060F_4	296.3	4.24	2.83	None	6500	4.85
5.0	2050F_4	343.3	2.08	1.39	None	5250	7.20
5.0	2060F_4	363.2	3.46	2.31	None	6500	5.82
4.0	2050F_4	417.1	1.71	1.14	None	5250	9.00
4.0	2060F_4	449.4	2.80	1.87	None	6500	7.27
4.0	2070F_4	443.8	4.06	2.71	None	8500	5.56
3.2	2060F_4	543.0	2.32	1.55	None	6500	9.09
3.2	2070F_4	542.7	3.30	2.20	None	8500	6.95
3.2	2080F_4	523.5	3.98	2.65	None	11000	5.37
2.7	2060F_4	649.5	1.94	1.29	None	6500	10.77
2.7	2070F_4	641.4	2.81	1.87	None	8500	8.24
2.7	2080F_4	638.7	4.14	2.76	None	11000	6.36
2.2	2060F_4	795.9	1.58	1.05	None	6500	13.22
2.2	2070F_4	785.9	2.29	1.53	None	8500	10.11
2.2	2080F_4	772.8	2.86	1.91	None	11000	7.81
1.8	2070F_4	961.2	1.86	1.24	None	8500	12.35
1.8	2080F_4	927.2	2.25	1.50	None	11000	9.55
1.8	2090F_4	945.2	4.44	2.96	None	14000	7.50

Motors are available from Regal Rexnord or Rexnord distributors.

1.5 HP/145T Motor

Energy Efficient Motor
Falk Part No. 2918105 TEFC, 1750 rpm 230/460 Volts, 3 Phase, 60 Hz, NEMA B, 1.15 Service Factor

Premium Efficiency Motor
Falk Part No. 2918125 TEFC, 1750 rpm 230/460 Volts, 3 Phase, 60 Hz, NEMA B, 1.15 Service Factor

Motors meeting other specifications are available upon request.

- ① Drive selections found in the Quick Selection Tables are based on an ambient temperature of 80°F (27°C) at sea level (0 to 2500 ft.). If the environmental factors differ for your specific application, the application-adjusted thermal rating must be calculated to verify the drive selection. See the Quick Selection example on page 11 and the application-adjusted thermal rating procedure on page 41.
- ② Published values of overhung load and sprocket pitch diameter are for loads applied one shaft diameter from the seal cage with a service factor of unity. Where overhung load is proportional to torque (i.e. pinion, sprocket or sheave applications) adjustment to the published values must be made based on the minimum required service factor. Refer to page 47 for additional information.

Quick Selection Tables

2 HP/1750 RPM/145T Motor ①

Approx. L.S. Shaft RPM	Drive Size & Reduction	Exact Ratio	HP Rating	Service Factor	Minimum Cooling Required	L.S. Shaft OHL Capacity (lb) ②	Minimum L.S. Shaft Sprocket Pitch Dia (in) ②
25.0	2040F_3	69.99	5.69	2.85	None	3400	2.96
20.0	2040F_3	82.37	4.79	2.40	None	3400	3.71
16.5	2040F_3	105.0	3.80	1.90	None	3400	4.49
13.5	2040F_3	125.0	3.16	1.58	None	3400	5.49
13.5	2050F_3	127.7	5.58	2.79	None	5250	3.56
11.0	2040F_3	159.4	2.50	1.25	None	3400	6.74
11.0	2050F_3	156.9	4.54	2.27	None	5250	4.36
9.0	2050F_4	187.5	3.53	1.77	None	5250	5.33
7.5	2050F_4	231.5	3.08	1.54	None	5250	6.40
7.5	2060F_4	239.6	5.17	2.59	None	6500	5.17
6.0	2050F_4	286.1	2.49	1.25	None	5250	8.00
6.0	2060F_4	296.3	4.24	2.12	None	6500	6.46
5.0	2050F_4	343.3	2.08	1.04	None	5250	9.60
5.0	2060F_4	363.2	3.46	1.73	None	6500	7.75
5.0	2070F_4	358.7	5.03	2.52	None	8500	5.93
4.0	2060F_4	449.4	2.80	1.40	None	6500	9.69
4.0	2070F_4	443.8	4.06	2.03	None	8500	7.41
4.0	2080F_4	436.4	5.06	2.53	None	11000	5.73
3.2	2060F_4	543.0	2.32	1.16	None	6500	12.12
3.2	2070F_4	542.7	3.30	1.65	None	8500	9.26
3.2	2080F_4	523.5	3.98	1.99	None	11000	7.16
2.7	2070F_4	641.4	2.81	1.41	None	8500	10.98
2.7	2080F_4	638.7	4.14	2.07	None	11000	8.48
2.2	2070F_4	785.9	2.29	1.15	None	8500	13.48
2.2	2080F_4	772.8	2.86	1.43	None	11000	10.41
2.2	2090F_4	783.1	5.36	2.68	None	14000	8.18
1.8	2080F_4	927.2	2.25	1.13	None	11000	12.73
1.8	2090F_4	945.2	4.44	2.22	None	14000	10.00
1.8	2100F_4	999.9	5.88	2.94	None	17000	8.24

Motors are available from Regal Rexnord™ or Rexnord™ distributors.

2 HP/145T Motor

Energy Efficient Motor
Falk™ Part No. 2918106 TEFC, 1750 rpm 208-230/460 Volts, 3 Phase, 60 Hz, NEMA B, 1.15 Service Factor

Premium Efficiency Motor
Falk Part No. 2918126 TEFC, 1750 rpm 230/460 Volts, 3 Phase, 60 Hz, NEMA B, 1.15 Service Factor

Motors meeting other specifications are available upon request.

3 HP/1750 RPM/182T Motor ①

Approx. L.S. Shaft RPM	Drive Size & Reduction	Exact Ratio	HP Rating	Service Factor	Minimum Cooling Required	L.S. Shaft OHL Capacity (lb) ②	Minimum L.S. Shaft Sprocket Pitch Dia (in) ②
37.0	2040F_3	45.86	8.67	2.89	None	3400	3.00
30.0	2040F_3	57.62	6.91	2.30	None	3400	3.71
25.0	2040F_3	69.99	5.69	1.90	None	3400	4.45
20.0	2040F_3	82.37	4.79	1.60	None	3400	5.56
20.0	2050F_3	84.70	8.41	2.80	None	5250	3.60
16.5	2040F_3	105.0	3.80	1.27	None	3400	6.74
16.5	2050F_3	104.1	6.85	2.28	None	5250	4.36
13.5	2040F_3	125.0	3.16	1.05	None	3400	8.24
13.5	2050F_3	127.7	5.58	1.86	None	5250	5.33
11.0	2050F_3	156.9	4.54	1.51	None	5250	6.55
11.0	2060F_3	156.7	7.96	2.65	None	6500	5.29
9.0	2050F_4	187.5	3.53	1.18	None	5250	8.00
9.0	2060F_3	190.1	6.62	2.21	None	6500	6.46
7.5	2050F_4	231.5	3.08	1.03	None	5250	9.60
7.5	2060F_4	239.6	5.17	1.72	None	6500	7.75
7.5	2070F_4	236.6	7.62	2.54	None	8500	5.93
6.0	2060F_4	296.3	4.24	1.41	None	6500	9.69
6.0	2070F_4	292.6	6.16	2.05	None	8500	7.41
5.0	2060F_4	363.2	3.46	1.15	None	6500	11.63
5.0	2070F_4	358.7	5.03	1.68	None	8500	8.89
5.0	2080F_4	360.7	7.32	2.44	None	11000	6.87
4.0	2070F_4	443.8	4.06	1.35	None	8500	11.12
4.0	2080F_4	436.4	5.06	1.69	None	11000	8.59
3.2	2070F_4	542.7	3.30	1.10	None	8500	13.90
3.2	2080F_4	523.5	3.98	1.33	None	11000	10.74
3.2	2090F_4	533.7	7.86	2.62	None	14000	8.44
2.7	2080F_4	638.7	4.14	1.38	None	11000	12.73
2.7	2090F_4	644.9	6.50	2.17	None	14000	10.00
2.7	2100F_4	660.4	8.90	2.97	None	17000	8.24
2.2	2090F_4	783.1	5.36	1.79	None	14000	12.27
2.2	2100F_4	844.5	6.90	2.30	None	17000	10.11
1.8	2090F_4	945.2	4.44	1.48	None	14000	15.00
1.8	2100F_4	999.9	5.88	1.96	None	17000	12.35
1.8	2110F_4	967.6	8.75	2.92	None	18500	11.35

Motors are available from Regal Rexnord or Rexnord distributors.

3 HP/182T Motor

Energy Efficient Motor
Falk Part No. 2918107 TEFC, 1750 rpm 208-230/460 Volts, 3 Phase, 60 Hz, NEMA B, 1.15 Service Factor

Premium Efficiency Motor
Falk Part No. 2918127 TEFC, 1750 rpm 230/460 Volts, 3 Phase, 60 Hz, NEMA B, 1.15 Service Factor

Motors meeting other specifications are available upon request.

① Drive selections found in the Quick Selection Tables are based on an ambient temperature of 80°F (27°C) at sea level (0 to 2500 ft.). If the environmental factors differ for your specific application, the application-adjusted thermal rating must be calculated to verify the drive selection. See the Quick Selection example on page 11 and the application-adjusted thermal rating procedure on page 41.

② Published values of overhung load and sprocket pitch diameter are for loads applied one shaft diameter from the seal cage with a service factor of unity. Where overhung load is proportional to torque (i.e. pinion, sprocket or sheave applications) adjustment to the published values must be made based on the minimum required service factor. Refer to page 47 for additional information.

Quick Selection Tables

5 HP/1750 RPM/184T Motor ①

Approx. L.S. Shaft RPM	Drive Size & Reduction	Exact Ratio	HP Rating	Service Factor	Minimum Cooling Required	L.S. Shaft OHL Capacity (lb) ②	Minimum L.S. Shaft Sprocket Pitch Dia (in) ②
68.0	2040F_2	25.25	14.6	2.92	None	3400	2.72
56.0	2040F_2	29.43	12.8	2.56	None	3400	3.31
45.0	2040F_3	38.08	10.4	2.08	None	3400	4.12
37.0	2040F_3	45.86	8.67	1.73	None	3400	5.01
30.0	2040F_3	57.62	6.91	1.38	None	3400	6.18
30.0	2050F_3	55.63	12.8	2.56	None	5250	4.00
25.0	2040F_3	69.99	5.69	1.14	None	3400	7.41
25.0	2050F_3	68.61	10.4	2.08	None	5250	4.80
20.0	2050F_3	84.70	8.41	1.68	None	5250	6.00
20.0	2060F_3	85.69	14.7	2.94	None	6500	4.85
16.5	2050F_3	104.1	6.85	1.37	None	5250	7.27
16.5	2060F_3	106.5	11.4	2.28	None	6500	5.87
13.5	2050F_3	127.7	5.58	1.12	None	5250	8.89
13.5	2060F_3	131.3	9.54	1.91	None	6500	7.18
13.5	2070F_3	129.6	13.9	2.78	None	8500	5.49
11.0	2060F_3	156.7	7.96	1.59	None	6500	8.81
11.0	2070F_3	151.1	11.9	2.38	None	8500	6.74
9.0	2060F_3	190.1	6.62	1.32	None	6500	10.77
9.0	2070F_3	184.8	9.65	1.93	None	8500	8.24
9.0	2080F_4	192.3	13.7	2.74	None	11000	6.36
7.5	2060F_4	239.6	5.17	1.03	None	6500	12.92
7.5	2070F_4	236.6	7.62	1.52	None	8500	9.88
7.5	2080F_4	237.8	11.1	2.22	None	11000	7.64
6.0	2070F_4	292.6	6.16	1.23	None	8500	12.35
6.0	2080F_4	291.5	9.06	1.81	None	11000	9.55
6.0	2090F_4	284.5	14.7	2.94	None	14000	7.50
5.0	2070F_4	358.7	5.03	1.01	None	8500	14.82
5.0	2080F_4	360.7	7.32	1.46	None	11000	11.45
5.0	2090F_4	351.9	11.9	2.38	None	14000	9.00
4.0	2080F_4	436.4	5.06	1.01	None	11000	14.32
4.0	2090F_4	431.4	9.72	1.94	None	14000	11.25
4.0	2100F_4	437.6	13.4	2.68	None	17000	9.26
3.2	2090F_4	533.7	7.86	1.57	None	14000	14.06
3.2	2100F_4	518.1	11.3	2.26	None	17000	11.58
2.7	2090F_4	644.9	6.50	1.30	None	14000	16.67
2.7	2100F_4	660.4	8.90	1.78	None	17000	13.73
2.7	2110F_4	653.6	12.9	2.58	None	18500	12.61
2.2	2090F_4	783.1	5.36	1.07	None	14000	20.45
2.2	2100F_4	844.5	6.90	1.38	None	17000	16.84
2.2	2110F_4	791.4	11.1	2.22	None	18500	15.48
2.2	2120F_4	783.6	14.8	2.96	None	19000	15.07
1.8	2100F_4	999.9	5.88	1.18	None	17000	20.59
1.8	2110F_4	967.6	8.75	1.75	None	18500	18.92
1.8	2120F_4	961.3	12.1	2.42	None	19000	18.42

Motors are available from Regal Rexnord™ or Rexnord™ distributors.

5 HP/184T Motor

Energy Efficient Motor
Falk™ Part No. 2918108 TEFC,
1750 rpm 208-230/460 Volts,
3 Phase, 60 Hz, NEMA B,
1.15 Service Factor

Premium Efficiency Motor
Falk Part No. 2918128 TEFC,
1750 rpm 230/460 Volts, 3 Phase,
60 Hz, NEMA B, 1.15 Service
Factor

Motors meeting other
specifications are available
upon request.

- ① Drive selections found in the Quick Selection Tables are based on an ambient temperature of 80°F (27°C) at sea level (0 to 2500 ft.). If the environmental factors differ for your specific application, the application-adjusted thermal rating must be calculated to verify the drive selection. See the Quick Selection example on page 11 and the application-adjusted thermal rating procedure on page 41.
- ② Published values of overhung load and sprocket pitch diameter are for loads applied one shaft diameter from the seal cage with a service factor of unity. Where overhung load is proportional to torque (i.e. pinion, sprocket or sheave applications) adjustment to the published values must be made based on the minimum required service factor. Refer to page 47 for additional information.

Quick Selection Tables

7.5 HP/1750 RPM/213T Motor ①

Approx. L.S. Shaft RPM	Drive Size & Reduction	Exact Ratio	HP Rating	Service Factor	Minimum Cooling Required	L.S. Shaft OHL Capacity (lb) ②	Minimum L.S. Shaft Sprocket Pitch Dia (in) ②
84.0	2040F_2	19.81	19.3	2.57	None	3400	3.31
68.0	2040F_2	25.25	14.6	1.95	None	3400	4.09
56.0	2040F_2	29.43	12.8	1.71	None	3400	4.96
45.0	2040F_3	38.08	10.4	1.39	None	3400	6.18
45.0	2050F_3	37.57	18.9	2.52	None	5250	4.00
37.0	2040F_3	45.86	8.67	1.16	None	3400	7.51
37.0	2050F_3	45.64	15.6	2.08	None	5250	4.86
30.0	2050F_3	55.63	12.8	1.71	None	5250	6.00
30.0	2060F_3	56.62	22.2	2.96	None	6500	4.85
25.0	2050F_3	68.61	10.4	1.39	None	5250	7.20
25.0	2060F_3	70.64	17.1	2.28	None	6500	5.82
20.0	2050F_3	84.70	8.41	1.12	None	5250	9.00
20.0	2060F_3	85.69	14.7	1.96	None	6500	7.27
20.0	2070F_3	86.43	20.8	2.77	None	8500	5.56
16.5	2060F_3	106.5	11.4	1.52	None	6500	8.81
16.5	2070F_3	101.7	17.7	2.36	None	8500	6.74
13.5	2060F_3	131.3	9.54	1.27	None	6500	10.77
13.5	2070F_3	129.6	13.9	1.85	None	8500	8.24
13.5	2080F_3	130.4	19.9	2.65	None	11000	6.36
11.0	2060F_3	156.7	7.96	1.06	None	6500	13.22
11.0	2070F_3	151.1	11.9	1.59	None	8500	10.11
11.0	2080F_3	156.4	16.3	2.17	None	11000	7.81
9.0	2070F_3	184.8	9.65	1.29	None	8500	12.35
9.0	2080F_4	192.3	13.7	1.83	None	11000	9.55
9.0	2090F_3	193.6	21.6	2.88	None	14000	7.50
7.5	2070F_4	236.6	7.62	1.02	None	8500	14.82
7.5	2080F_4	237.8	11.1	1.48	None	11000	11.45
7.5	2090F_4	236.7	17.7	2.36	None	14000	9.00
6.0	2080F_4	291.5	9.06	1.21	None	11000	14.32
6.0	2090F_4	284.5	14.7	1.96	None	14000	11.25
6.0	2100F_4	306.1	19.2	2.56	None	17000	9.26
5.0	2090F_4	351.9	11.9	1.59	None	14000	13.50
5.0	2100F_4	371.9	15.8	2.11	None	17000	11.12
4.0	2090F_4	431.4	9.72	1.30	None	14000	16.88
4.0	2100F_4	437.6	13.4	1.79	None	17000	13.90
4.0	2110F_4	434.9	20.1	2.68	None	18500	12.77
3.2	2090F_4	533.7	7.86	1.05	None	14000	21.09
3.2	2100F_4	518.1	11.3	1.51	None	17000	17.37
3.2	2110F_4	531.7	15.9	2.12	None	18500	15.96
3.2	2120F_4	535.7	21.7	2.89	None	19000	15.54
2.7	2100F_4	660.4	8.90	1.19	None	17000	20.59
2.7	2110F_4	653.6	12.9	1.72	None	18500	18.92
2.7	2120F_4	657.2	17.7	2.36	None	19000	18.42
2.2	2110F_4	791.4	11.1	1.48	None	18500	23.22
2.2	2120F_4	783.6	14.8	1.97	None	19000	22.61
2.2	2130F_4	782.8	18.3	2.44	None	22500	19.09
1.8	2110F_4	967.6	8.75	1.17	None	18500	28.38
1.8	2120F_4	961.3	12.1	1.61	None	19000	27.63
1.8	2130F_4	940.9	15.4	2.05	None	22500	23.33

Motors are available from Regal Rexnord™ or Rexnord™ distributors.

7.5 HP/213T Motor

Energy Efficient Motor
Falk™ Part No. 2918109 TEFC,
1750 rpm 208-230/460 Volts,
3 Phase, 60 Hz, NEMA B,
1.15 Service Factor

Premium Efficiency Motor
Falk Part No. 2918129 TEFC,
1750 rpm 230/460 Volts, 3 Phase,
60 Hz, NEMA B, 1.15 Service
Factor

Motors meeting other
specifications are available
upon request.

① Drive selections found in the Quick Selection Tables are based on an ambient temperature of 80°F (27°C) at sea level (0 to 2500 ft.). If the environmental factors differ for your specific application, the application-adjusted thermal rating must be calculated to verify the drive selection. See the Quick Selection example on page 11 and the application-adjusted thermal rating procedure on page 41.

② Published values of overhung load and sprocket pitch diameter are for loads applied one shaft diameter from the seal cage with a service factor of unity. Where overhung load is proportional to torque (i.e. pinion, sprocket or sheave applications) adjustment to the published values must be made based on the minimum required service factor. Refer to page 47 for additional information.

Quick Selection Tables

10 HP/1750 RPM/215T Motor ①

Approx. L.S. Shaft RPM	Drive Size & Reduction	Exact Ratio	HP Rating	Service Factor	Minimum Cooling Required	L.S. Shaft OHL Capacity (lb) ②	Minimum L.S. Shaft Sprocket Pitch Dia (in) ②
420	2040F_2	4.120	28.5	2.85	None	2530	1.19
380	2040F_2	4.655	28.5	2.85	None	2650	1.25
125	2040F_2	13.86	28.1	2.81	None	3030	3.33
100	2040F_2	16.83	23.3	2.33	None	3030	4.16
84.0	2040F_2	19.81	19.3	1.93	None	3400	4.41
68.0	2040F_2	25.25	14.6	1.46	None	3400	5.45
68.0	2050F_2	25.27	28.0	2.80	None	5250	3.53
56.0	2040F_2	29.43	12.8	1.28	None	3400	6.62
56.0	2050F_2	30.16	23.5	2.35	None	5250	4.29
45.0	2040F_3	38.08	10.4	1.04	None	3400	8.24
45.0	2050F_3	37.57	18.9	1.89	None	5250	5.33
37.0	2050F_3	45.64	15.6	1.56	None	5250	6.49
37.0	2060F_3	46.65	26.9	2.69	None	6500	5.24
30.0	2050F_3	55.63	12.8	1.28	None	5250	8.00
30.0	2060F_3	56.62	22.2	2.22	None	6500	6.46
25.0	2050F_3	68.61	10.4	1.04	None	5250	9.60
25.0	2060F_3	70.64	17.1	1.71	None	6500	7.75
25.0	2070F_3	71.14	25.3	2.53	None	8500	5.93
20.0	2060F_3	85.69	14.7	1.47	None	6500	9.69
20.0	2070F_3	86.43	20.8	2.08	None	8500	7.41
16.5	2060F_3	106.5	11.4	1.14	None	6500	11.75
16.5	2070F_3	101.7	17.7	1.77	None	8500	8.98
16.5	2080F_3	107.7	23.8	2.38	None	11000	6.94
13.5	2070F_3	129.6	13.9	1.39	None	8500	10.98
13.5	2080F_3	130.4	19.9	1.99	None	11000	8.48
11.0	2070F_3	151.1	11.9	1.19	None	8500	13.48
11.0	2080F_3	156.4	16.3	1.63	None	11000	10.41
11.0	2090F_3	157.5	26.6	2.66	None	14000	8.18
9.0	2080F_4	192.3	13.7	1.37	None	11000	12.73
9.0	2090F_3	193.6	21.6	2.16	None	14000	10.00
9.0	2100F_4	202.3	28.9	2.89	None	17000	8.24
7.5	2080F_4	237.8	11.1	1.11	None	11000	15.27
7.5	2090F_4	236.7	17.7	1.77	None	14000	12.00
7.5	2100F_4	243.7	24.1	2.41	None	17000	9.88
6.0	2090F_4	284.5	14.7	1.47	None	14000	15.00
6.0	2100F_4	306.1	19.2	1.92	None	17000	12.35
5.0	2090F_4	351.9	11.9	1.19	None	14000	18.00
5.0	2100F_4	371.9	15.8	1.58	None	17000	14.82
5.0	2110F_4	352.3	24.8	2.48	None	18500	13.62
4.0	2100F_4	437.6	13.4	1.34	None	17000	18.53
4.0	2110F_4	434.9	20.1	2.01	None	18500	17.03
4.0	2120F_4	445.7	26.0	2.60	None	19000	16.58
3.2	2100F_4	518.1	11.3	1.13	None	17000	23.16
3.2	2110F_4	531.7	15.9	1.59	None	18500	21.28
3.2	2120F_4	535.7	21.7	2.17	None	19000	20.72
2.7	2110F_4	653.6	12.9	1.29	None	18500	25.23
2.7	2120F_4	657.2	17.7	1.77	None	19000	24.56
2.7	2130F_4	643.3	25.9	2.59	None	22500	20.74
2.2	2110F_4	791.4	11.1	1.11	None	18500	30.96
2.2	2120F_4	783.6	14.8	1.48	None	19000	30.14
2.2	2130F_4	782.8	18.3	1.83	None	22500	25.45
1.8	2120F_4	961.3	12.1	1.21	None	19000	36.84
1.8	2130F_4	940.9	15.4	1.54	None	22500	31.11

Motors are available from Regal Rexnord™ or Rexnord™ distributors.

10 HP/215T Motor

Energy Efficient Motor
Falk™ Part No. 2918110 TEFC, 1750 rpm 208-230/460 Volts, 3 Phase, 60 Hz, NEMA B, 1.15 Service Factor

Premium Efficiency Motor
Falk Part No. 2918130 TEFC, 1750 rpm 230/460 Volts, 3 Phase, 60 Hz, NEMA B, 1.15 Service Factor

Motors meeting other specifications are available upon request.

- ① Drive selections found in the Quick Selection Tables are based on an ambient temperature of 80°F (27°C) at sea level (0 to 2500 ft.). If the environmental factors differ for your specific application, the application-adjusted thermal rating must be calculated to verify the drive selection. See the Quick Selection example on page 11 and the application-adjusted thermal rating procedure on page 41.
- ② Published values of overhung load and sprocket pitch diameter are for loads applied one shaft diameter from the seal cage with a service factor of unity. Where overhung load is proportional to torque (i.e. pinion, sprocket or sheave applications) adjustment to the published values must be made based on the minimum required service factor. Refer to page 47 for additional information.

Quick Selection Tables

15 HP/1750 RPM/254T Motor ①

Approx. L.S. Shaft RPM	Drive Size & Reduction	Exact Ratio	HP Rating	Service Factor	Minimum Cooling Required	L.S. Shaft OHL Capacity (lb) ②	Minimum L.S. Shaft Sprocket Pitch Dia (in) ②
640	2040F_2	2.723	39.8	2.65	None	2380	1.24
575	2040F_2	3.076	39.8	2.65	None	2380	1.38
520	2040F_2	3.279	34.7	2.31	None	2530	1.44
470	2040F_2	3.705	34.7	2.31	None	2530	1.59
420	2040F_2	4.120	28.5	1.90	None	2530	1.78
380	2040F_2	4.655	28.5	1.90	None	2650	1.88
230	2040F_2	7.368	44.7	2.98	None	2380	3.45
190	2040F_2	9.158	38.2	2.55	None	2670	3.73
155	2040F_2	11.03	33.3	2.22	None	2840	4.29
125	2040F_2	13.86	28.1	1.87	None	3030	4.99
100	2040F_2	16.83	23.3	1.55	None	3030	6.24
100	2050F_2	16.65	42.3	2.82	None	4370	4.32
84	2040F_2	19.81	19.3	1.29	None	3400	6.62
84	2050F_2	20.56	34.4	2.29	None	5120	4.39
68	2050F_2	25.27	28.0	1.87	None	5250	5.29
56	2050F_2	30.16	23.5	1.57	None	5250	6.43
56	2060F_2	31.69	39.7	2.65	None	6500	5.19
45	2050F_3	37.57	18.9	1.26	None	5250	8.00
45	2060F_3	38.46	32.3	2.15	None	6500	6.46
37	2050F_3	45.64	15.6	1.04	None	5250	9.73
37	2060F_3	46.65	26.9	1.79	None	6500	7.86
37	2070F_3	46.27	37.8	2.52	None	8500	6.01
30	2060F_3	56.62	22.2	1.48	None	6500	9.69
30	2070F_3	56.63	31.7	2.11	None	8500	7.41
30	2080F_3	57.56	44.9	2.99	None	11000	5.73
25	2060F_3	70.64	17.1	1.14	None	6500	11.63
25	2070F_3	71.14	25.3	1.69	None	8500	8.89
25	2080F_3	69.64	36.9	2.46	None	11000	6.87
20	2070F_3	86.43	20.8	1.39	None	8500	11.12
20	2080F_3	87.65	30.1	2.01	None	11000	8.59
16.5	2070F_3	101.7	17.7	1.18	None	8500	13.48
16.5	2080F_3	107.7	23.8	1.59	None	11000	10.41
16.5	2090F_3	103.4	40.4	2.69	None	14000	8.18
13.5	2080F_3	130.4	19.9	1.33	None	11000	12.73
13.5	2090F_3	129.7	32.3	2.15	None	14000	10.00
13.5	2100F_3	133.8	43.8	2.92	None	17000	8.24
11.0	2080F_3	156.4	16.3	1.09	None	11000	15.62
11.0	2090F_3	157.5	26.6	1.77	None	14000	12.27
11.0	2100F_3	158.4	37.0	2.47	None	17000	10.11
9.0	2090F_3	193.6	21.6	1.44	None	14000	15.00
9.0	2100F_4	202.3	28.9	1.93	None	17000	12.35
7.5	2090F_4	236.7	17.7	1.18	None	14000	18.00
7.5	2100F_4	243.7	24.1	1.61	None	17000	14.82
7.5	2110F_4	234.3	37.3	2.49	None	18500	13.62
6.0	2100F_4	306.1	19.2	1.28	None	17000	18.53
6.0	2110F_4	285.6	30.6	2.04	None	18500	17.03
6.0	2120F_4	292.7	39.6	2.64	None	19000	16.58
5.0	2100F_4	371.9	15.8	1.05	None	17000	22.24
5.0	2110F_4	352.3	24.8	1.65	None	18500	20.43
5.0	2120F_4	361.0	32.1	2.14	None	19000	19.89
4.0	2110F_4	434.9	20.1	1.34	None	18500	25.54
4.0	2120F_4	445.7	26.0	1.73	None	19000	24.87
4.0	2130F_4	433.5	38.5	2.57	None	22500	21.00
3.2	2110F_4	531.7	15.9	1.06	None	18500	31.93
3.2	2120F_4	535.7	21.7	1.45	None	19000	31.09
3.2	2130F_4	535.1	31.1	2.07	None	22500	26.25
2.7	2120F_4	657.2	17.7	1.18	None	19000	36.84
2.7	2130F_4	643.3	25.9	1.73	None	22500	31.11
2.2	2130F_4	782.8	18.3	1.22	None	22500	38.18
1.8	2130F_4	940.9	15.4	1.03	None	22500	46.67

Motors are available from Regal Rexnord™ or Rexnord™ distributors.

15 HP/254T Motor

Energy Efficient Motor

Falk™ Part No. 2918111 TEFC, 1750 rpm 230/460 Volts, 3 Phase, 60 Hz, NEMA B, 1.15 Service Factor

Premium Efficiency Motor

Falk Part No. 2918131 TEFC, 1750 rpm 230/460 Volts, 3 Phase, 60 Hz, NEMA B, 1.15 Service Factor

Motors meeting other specifications are available upon request.

① Drive selections found in the Quick Selection Tables are based on an ambient temperature of 80°F (27°C) at sea level (0 to 2500 ft.). If the environmental factors differ for your specific application, the application-adjusted thermal rating must be calculated to verify the drive selection. See the Quick Selection example on page 11 and the application-adjusted thermal rating procedure on page 41.

② Published values of overhung load and sprocket pitch diameter are for loads applied one shaft diameter from the seal cage with a service factor of unity. Where overhung load is proportional to torque (i.e. pinion, sprocket or sheave applications) adjustment to the published values must be made based on the minimum required service factor. Refer to page 47 for additional information.

Quick Selection Tables

20 HP/1750 RPM/256T Motor ①

Approx. L.S. Shaft RPM	Drive Size & Reduction	Exact Ratio	HP Rating	Service Factor	Minimum Cooling Required	L.S. Shaft OHL Capacity (lb) ②	Minimum L.S. Shaft Sprocket Pitch Dia (in) ②
1170	2040F 2	1.465	57.6	2.88	None	2030	1.06
950	2040F 2	1.820	50.8	2.54	None	2040	1.30
860	2040F 2	2.057	50.8	2.54	None	2150	1.36
780	2040F 2	2.191	50.1	2.50	None	2200	1.47
700	2040F 2	2.475	45.4	2.27	None	2290	1.57
640	2040F 2	2.723	39.8	1.99	None	2380	1.65
575	2040F 2	3.076	39.8	1.99	None	2380	1.84
520	2040F 2	3.279	34.7	1.74	None	2530	1.92
470	2040F 2	3.705	34.7	1.74	None	2530	2.12
420	2040F 2	4.120	28.5	1.43	None	2530	2.37
420	2050F 2	4.001	56.7	2.84	None	2730	2.20
380	2040F 2	4.655	28.5	1.43	None	2650	2.50
350	2040F 2	4.929	57.6	2.88	None	2260	3.19
280	2040F 2	6.122	50.8	2.54	None	2280	3.95
230	2040F 2	7.368	44.7	2.24	None	2380	4.60
190	2040F 2	9.158	38.2	1.91	None	2670	4.97
155	2040F 2	11.03	33.3	1.67	None	2840	5.72
125	2040F 2	13.86	28.1	1.41	None	3030	6.65
125	2050F 2	13.50	52.1	2.61	None	4370	4.61
100	2040F 2	16.83	23.3	1.17	None	3030	8.32
100	2050F 2	16.65	42.3	2.12	None	4370	5.77
84	2050F 2	20.56	34.4	1.72	None	5120	5.86
84	2060F 2	21.13	59.3	2.97	None	6500	4.62
68	2050F 2	25.27	28.0	1.40	None	5250	7.06
68	2060F 2	25.63	49.0	2.45	None	6500	5.70
56	2050F 2	30.16	23.5	1.18	None	5250	8.57
56	2060F 2	31.69	39.7	1.99	None	6500	6.92
56	2070F 2	31.08	53.1	2.66	None	8500	5.29
45	2060F 3	38.46	32.3	1.62	None	6500	8.62
45	2070F 3	37.83	46.2	2.31	None	8500	6.59
37	2060F 3	46.65	26.9	1.35	None	6500	10.48
37	2070F 3	46.27	37.8	1.89	None	8500	8.01
37	2080F 3	47.23	53.9	2.70	None	11000	6.19
30	2060F 3	56.62	22.2	1.11	None	6500	12.92
30	2070F 3	56.63	31.7	1.59	None	8500	9.88
30	2080F 3	57.56	44.9	2.25	None	11000	7.64
25	2070F 3	71.14	25.3	1.27	None	8500	11.86
25	2080F 3	69.64	36.9	1.85	None	11000	9.16
25	2090F 3	69.86	59.8	2.99	None	14000	7.20
20	2070F 3	86.43	20.8	1.04	None	8500	14.82
20	2080F 3	87.65	30.1	1.51	None	11000	11.45
20	2090F 3	85.18	49.1	2.46	None	14000	9.00
16.5	2080F 3	107.7	23.8	1.19	None	11000	13.88
16.5	2090F 3	103.4	40.4	2.02	None	14000	10.91
16.5	2100F 3	104.6	56.0	2.80	None	17000	8.98
13.5	2080F 3	130.4	19.9	1.00	None	11000	16.97
13.5	2090F 3	129.7	32.3	1.62	None	14000	13.33
13.5	2100F 3	133.8	43.8	2.19	None	17000	10.98
11.0	2090F 3	157.5	26.6	1.33	None	14000	16.36
11.0	2100F 3	158.4	37.0	1.85	None	17000	13.48
11.0	2110F 3	155.7	53.8	2.69	None	18500	12.38
9.0	2090F 3	193.6	21.6	1.08	None	14000	20.00
9.0	2100F 4	202.3	28.9	1.45	None	17000	16.47
9.0	2110F 4	192.9	45.3	2.27	None	18500	15.14
9.0	2120F 4	197.7	58.6	2.93	None	19000	14.74
7.5	2100F 4	243.7	24.1	1.21	None	17000	19.76
7.5	2110F 4	234.3	37.3	1.87	None	18500	18.16
7.5	2120F 4	240.1	48.3	2.42	None	19000	17.68
6.0	2110F 4	285.6	30.6	1.53	None	18500	22.70
6.0	2120F 4	292.7	39.6	1.98	None	19000	22.11
6.0	2130F 4	288.4	57.8	2.89	None	22500	18.67
5.0	2110F 4	352.3	24.8	1.24	None	18500	27.24
5.0	2120F 4	361.0	32.1	1.61	None	19000	26.53
5.0	2130F 4	351.4	47.4	2.37	None	22500	22.40
4.0	2110F 4	434.9	20.1	1.01	None	18500	34.05
4.0	2120F 4	445.7	26.0	1.30	None	19000	33.16
4.0	2130F 4	433.5	38.5	1.93	None	22500	28.00
3.2	2120F 4	535.7	21.7	1.09	None	19000	41.45
3.2	2130F 4	535.1	31.1	1.56	None	22500	35.00
2.7	2130F 4	643.3	25.9	1.30	None	22500	41.48

Motors are available from Regal Rexnord™ or Rexnord™ distributors.

20 HP/256T Motor

Energy Efficient Motor

Falk™ Part No. 2918112 TEFC, 1750 rpm 230/460 Volts, 3 Phase, 60 Hz, NEMA B, 1.15 Service Factor

Premium Efficiency Motor

Falk Part No. 2918132 TEFC, 1750 rpm 230/460 Volts, 3 Phase, 60 Hz, NEMA B, 1.15 Service Factor

Motors meeting other specifications are available upon request.

① Drive selections found in the Quick Selection Tables are based on an ambient temperature of 80°F (27°C) at sea level (0 to 2500 ft.). If the environmental factors differ for your specific application, the application-adjusted thermal rating must be calculated to verify the drive selection. See the Quick Selection example on page 11 and the application-adjusted thermal rating procedure on page 41.

② Published values of overhung load and sprocket pitch diameter are for loads applied one shaft diameter from the seal cage with a service factor of unity. Where overhung load is proportional to torque (i.e. pinion, sprocket or sheave applications) adjustment to the published values must be made based on the minimum required service factor. Refer to page 47 for additional information.

Quick Selection Tables

25 HP/1750 RPM/284T Motor ①

Approx. L.S. Shaft RPM	Drive Size & Reduction	Exact Ratio	HP Rating	Service Factor	Minimum Cooling Required	L.S. Shaft OHL Capacity (lb) ②	Minimum L.S. Shaft Sprocket Pitch Dia (in) ②
1170	2040F 2	1.465	57.6	2.30	None	2030	1.33
950	2040F 2	1.820	50.8	2.03	None	2040	1.63
860	2040F 2	2.057	50.8	2.03	None	2150	1.70
780	2040F 2	2.191	50.1	2.00	None	2200	1.84
700	2040F 2	2.475	45.4	1.82	None	2290	1.97
640	2040F 2	2.723	39.8	1.59	None	2380	2.07
575	2040F 2	3.076	39.8	1.59	None	2380	2.30
520	2040F 2	3.279	34.7	1.39	None	2530	2.39
520	2050F 2	3.283	68.0	2.72	None	2730	2.22
470	2040F 2	3.705	34.7	1.39	None	2530	2.65
420	2040F 2	4.120	28.5	1.14	None	2530	2.96
420	2050F 2	4.001	56.7	2.27	None	2730	2.75
380	2040F 2	4.655	28.5	1.14	None	2650	3.13
380	2050F 2	4.512	68.0	2.72	None	3140	2.64
350	2040F 2	4.929	57.6	2.30	None	2260	3.98
280	2040F 2	6.122	50.8	2.03	None	2280	4.93
230	2040F 2	7.368	44.7	1.79	None	2380	5.75
190	2040F 2	9.158	38.2	1.53	None	2670	6.21
155	2040F 2	11.03	33.3	1.33	None	2840	7.16
155	2050F 2	11.08	63.2	2.53	None	4020	5.06
125	2040F 2	13.86	28.1	1.12	None	3030	8.32
125	2050F 2	13.50	52.1	2.08	None	4370	5.77
100	2050F 2	16.65	42.3	1.69	None	4370	7.21
100	2060F 2	17.19	69.8	2.79	None	6500	4.85
84	2050F 2	20.56	34.4	1.38	None	5120	7.32
84	2060F 2	21.13	59.3	2.37	None	6500	5.77
68	2050F 2	25.27	28.0	1.12	None	5250	8.82
68	2060F 2	25.63	49.0	1.96	None	6500	7.13
68	2070F 2	25.12	68.0	2.72	None	8500	5.45
56	2060F 2	31.69	39.7	1.59	None	6500	8.65
56	2070F 2	31.08	53.1	2.12	None	8500	6.62
45	2060F 3	38.46	32.3	1.29	None	6500	10.77
45	2070F 3	37.83	46.2	1.85	None	8500	8.24
45	2080F 3	38.88	63.7	2.55	None	11000	6.36
37	2060F 3	46.65	26.9	1.08	None	6500	13.10
37	2070F 3	46.27	37.8	1.51	None	8500	10.02
37	2080F 3	47.23	53.9	2.16	None	11000	7.74
30	2070F 3	56.63	31.7	1.27	None	8500	12.35
30	2080F 3	57.56	44.9	1.80	None	11000	9.55
30	2090F 3	57.53	72.3	2.89	None	14000	7.50
25	2070F 3	71.14	25.3	1.01	None	8500	14.82
25	2080F 3	69.64	36.9	1.48	None	11000	11.45
25	2090F 3	69.86	59.8	2.39	None	14000	9.00
20	2080F 3	87.65	30.1	1.20	None	11000	14.32
20	2090F 3	85.18	49.1	1.96	None	14000	11.25
20	2100F 3	88.36	66.2	2.65	None	17000	9.26
16.5	2090F 3	103.4	40.4	1.62	None	14000	13.64
16.5	2100F 3	104.6	56.0	2.24	None	17000	11.23
13.5	2090F 3	129.7	32.3	1.29	None	14000	16.67
13.5	2100F 3	133.8	43.8	1.75	None	17000	13.73
13.5	2110F 3	128.2	65.1	2.60	None	18500	12.61
11.0	2090F 3	157.5	26.6	1.06	None	14000	20.45
11.0	2100F 3	158.4	37.0	1.48	None	17000	16.84
11.0	2110F 3	155.7	53.8	2.15	None	18500	15.48
11.0	2120F 3	158.2	73.2	2.93	None	19000	15.07
9.0	2100F 4	202.3	28.9	1.16	None	17000	20.59
9.0	2110F 4	192.9	45.3	1.81	None	18500	18.92
9.0	2120F 4	197.7	58.6	2.34	None	19000	18.42
7.5	2110F 4	234.3	37.3	1.49	None	18500	22.70
7.5	2120F 4	240.1	48.3	1.93	None	19000	22.11
7.5	2130F 4	237.4	67.0	2.68	None	22500	18.67
6.0	2110F 4	285.6	30.6	1.22	None	18500	28.38
6.0	2120F 4	292.7	39.6	1.58	None	19000	27.63
6.0	2130F 4	288.4	57.8	2.31	None	22500	23.33
5.0	2120F 4	361.0	32.1	1.28	None	19000	33.16
5.0	2130F 4	351.4	47.4	1.90	None	22500	28.00
4.0	2120F 4	445.7	26.0	1.04	None	19000	41.45
4.0	2130F 4	433.5	38.5	1.54	None	22500	35.00
3.2	2130F 4	535.1	31.1	1.24	None	22500	43.75
2.7	2130F 4	643.3	25.9	1.04	None	22500	51.85

Motors are available from Regal Rexnord™ or Rexnord™ distributors.

25 HP/284T Motor

Energy Efficient Motor

Falk™ Part No. 2918113 TEFC, 1750 rpm 230/460 Volts, 3 Phase, 60 Hz, NEMA B, 1.15 Service Factor

Premium Efficiency Motor

Falk Part No. 2918133 TEFC, 1750 rpm 230/460 Volts, 3 Phase, 60 Hz, NEMA B, 1.15 Service Factor

Motors meeting other specifications are available upon request.

① Drive selections found in the Quick Selection Tables are based on an ambient temperature of 80°F (27°C) at sea level (0 to 2500 ft.). If the environmental factors differ for your specific application, the application-adjusted thermal rating must be calculated to verify the drive selection. See the Quick Selection example on page 11 and the application-adjusted thermal rating procedure on page 41.

② Published values of overhung load and sprocket pitch diameter are for loads applied one shaft diameter from the seal cage with a service factor of unity. Where overhung load is proportional to torque (i.e. pinion, sprocket or sheave applications) adjustment to the published values must be made based on the minimum required service factor. Refer to page 47 for additional information.

Quick Selection Tables

30 HP/1750 RPM/286T Motor ①

Approx. L.S. Shaft RPM	Drive Size & Reduction	Exact Ratio	HP Rating	Service Factor	Minimum Cooling Required	L.S. Shaft OHL Capacity (lb) ②	Minimum L.S. Shaft Sprocket Pitch Dia (in) ②
1170	2040F 2	1.465	57.6	1.92	None	2030	1.59
950	2040F 2	1.820	50.8	1.69	None	2040	1.95
950	2050F 2	1.822	87.5	2.92	None	2450	1.62
860	2040F 2	2.057	50.8	1.69	None	2150	2.04
780	2040F 2	2.191	50.1	1.67	None	2200	2.20
700	2040F 2	2.475	45.4	1.51	None	2290	2.36
640	2040F 2	2.723	39.8	1.33	None	2380	2.48
640	2050F 2	2.702	79.2	2.64	None	2580	2.29
575	2040F 2	3.076	39.8	1.33	None	2380	2.76
520	2040F 2	3.279	34.7	1.16	None	2530	2.87
520	2050F 2	3.283	68.0	2.27	None	2730	2.66
470	2040F 2	3.705	34.7	1.16	None	2530	3.18
470	2050F 2	3.714	79.2	2.64	None	2730	2.95
420	2050F 2	4.001	56.7	1.89	None	2730	3.30
380	2050F 2	4.512	68.0	2.27	None	3140	3.17
350	2040F 2	4.929	57.6	1.92	None	2260	4.78
280	2040F 2	6.122	50.8	1.69	None	2280	5.92
230	2040F 2	7.368	44.7	1.49	None	2380	6.91
230	2050F 2	7.598	87.0	2.90	None	3300	4.98
190	2040F 2	9.158	38.2	1.27	None	2670	7.45
190	2050F 2	9.119	76.5	2.55	None	3700	5.38
155	2040F 2	11.03	33.3	1.11	None	2840	8.59
155	2050F 2	11.08	63.2	2.11	None	4020	6.07
125	2050F 2	13.50	52.1	1.74	None	4370	6.92
100	2050F 2	16.65	42.3	1.41	None	4370	8.65
100	2060F 2	17.19	69.8	2.33	None	6500	5.82
84	2050F 2	20.56	34.4	1.15	None	5120	8.79
84	2060F 2	21.13	59.3	1.98	None	6500	6.92
84	2070F 2	20.54	84.8	2.83	None	8500	5.29
68	2060F 2	25.63	49.0	1.63	None	6500	8.55
68	2070F 2	25.12	68.0	2.27	None	8500	6.54
56	2060F 2	31.69	39.7	1.32	None	6500	10.38
56	2070F 2	31.08	53.1	1.77	None	8500	7.94
56	2080F 2	31.15	77.7	2.59	None	11000	6.14
45	2060F 3	38.46	32.3	1.08	None	6500	12.92
45	2070F 3	37.83	46.2	1.54	None	8500	9.88
45	2080F 3	38.88	63.7	2.12	None	11000	7.64
37	2070F 3	46.27	37.8	1.26	None	8500	12.02
37	2080F 3	47.23	53.9	1.80	None	11000	9.29
37	2090F 3	48.23	86.3	2.88	None	14000	7.30
30	2070F 3	56.63	31.7	1.06	None	8500	14.82
30	2080F 3	57.56	44.9	1.50	None	11000	11.45
30	2090F 3	57.53	72.3	2.41	None	14000	9.00
25	2080F 3	69.64	36.9	1.23	None	11000	13.75
25	2090F 3	69.86	59.8	1.99	None	14000	10.80
25	2100F 3	71.64	81.6	2.72	None	17000	8.89
20	2080F 3	87.65	30.1	1.00	None	11000	17.18
20	2090F 3	85.18	49.1	1.64	None	14000	13.50
20	2100F 3	88.36	66.2	2.21	None	17000	11.12
16.5	2090F 3	103.4	40.4	1.35	None	14000	16.36
16.5	2100F 3	104.6	56.0	1.87	None	17000	13.48
16.5	2110F 3	104.9	82.5	2.75	None	18500	12.38
13.5	2090F 3	129.7	32.3	1.08	None	14000	20.00
13.5	2100F 3	133.8	43.8	1.46	None	17000	16.47
13.5	2110F 3	128.2	65.1	2.17	None	18500	15.14
13.5	2120F 3	128.9	89.7	2.99	None	19000	14.74
11.0	2100F 3	158.4	37.0	1.23	None	17000	20.21
11.0	2110F 3	155.7	53.8	1.79	None	18500	18.57
11.0	2120F 3	158.2	73.2	2.44	None	19000	18.09
9.0	2110F 4	192.9	45.3	1.51	None	18500	22.70
9.0	2120F 4	197.7	58.6	1.95	None	19000	22.11
9.0	2130F 4	199.0	81.0	2.70	None	22500	18.67
7.5	2110F 4	234.3	37.3	1.24	None	18500	27.24
7.5	2120F 4	240.1	48.3	1.61	None	19000	26.53
7.5	2130F 4	237.4	67.0	2.23	None	22500	22.40
6.0	2110F 4	285.6	30.6	1.02	None	18500	34.05
6.0	2120F 4	292.7	39.6	1.32	None	19000	33.16
6.0	2130F 4	288.4	57.8	1.93	None	22500	28.00
5.0	2120F 4	361.0	32.1	1.07	None	19000	39.79
5.0	2130F 4	351.4	47.4	1.58	None	22500	33.60
4.0	2130F 4	433.5	38.5	1.28	None	22500	42.00
3.2	2130F 4	535.1	31.1	1.04	None	22500	52.50

Motors are available from Regal Rexnord™ or Rexnord™ distributors.

30 HP/286T Motor

Energy Efficient Motor

Falk™ Part No. 2918114 TEFC, 1750 rpm 230/460 Volts, 3 Phase, 60 Hz, NEMA B, 1.15 Service Factor

Premium Efficiency Motor

Falk Part No. 2918134 TEFC, 1750 rpm 230/460 Volts, 3 Phase, 60 Hz, NEMA B, 1.15 Service Factor

Motors meeting other specifications are available upon request.

① Drive selections found in the Quick Selection Tables are based on an ambient temperature of 80°F (27°C) at sea level (0 to 2500 ft.). If the environmental factors differ for your specific application, the application-adjusted thermal rating must be calculated to verify the drive selection. See the Quick Selection example on page 11 and the application-adjusted thermal rating procedure on page 41.

② Published values of overhung load and sprocket pitch diameter are for loads applied one shaft diameter from the seal cage with a service factor of unity. Where overhung load is proportional to torque (i.e. pinion, sprocket or sheave applications) adjustment to the published values must be made based on the minimum required service factor. Refer to page 47 for additional information.

Quick Selection Tables

40 HP/1750 RPM/324T Motor ①

Approx. L.S. Shaft RPM	Drive Size & Reduction	Exact Ratio	HP Rating	Service Factor	Minimum Cooling Required	L.S. Shaft OHL Capacity (lb) ②	Minimum L.S. Shaft Sprocket Pitch Dia (in) ②
1170	2040F 2	1.465	57.6	1.44	None	2030	2.12
1170	2050F 2	1.476	115	2.88	None	2420	1.78
950	2040F 2	1.820	50.8	1.27	None	2040	2.60
950	2050F 2	1.822	87.5	2.19	None	2450	2.17
860	2040F 2	2.057	50.8	1.27	None	2150	2.73
860	2050F 2	2.028	115	2.88	None	2320	2.53
780	2040F 2	2.191	50.1	1.25	None	2200	2.94
780	2050F 2	2.252	90.3	2.26	None	2660	2.43
700	2040F 2	2.475	45.4	1.14	None	2290	3.14
700	2050F 2	2.504	102	2.55	None	2530	2.85
640	2040F 2	2.723	39.8	1.00	None	2380	3.31
640	2050F 2	2.702	79.2	1.98	None	2580	3.05
575	2040F 2	3.076	39.8	1.00	None	2380	3.68
575	2050F 2	3.095	90.3	2.26	None	2580	3.40
520	2050F 2	3.283	68.0	1.70	None	2730	3.55
470	2050F 2	3.714	79.2	1.98	None	2730	3.93
420	2050F 2	4.001	56.7	1.42	None	2730	4.40
420	2060F 2	4.130	114	2.85	None	5450	2.20
380	2050F 2	4.512	68.0	1.70	None	3140	4.22
380	2060F 2	4.567	114	2.85	None	5750	2.31
350	2040F 2	4.929	57.6	1.44	None	2260	6.37
350	2050F 2	4.980	114	2.85	None	3120	4.62
280	2040F 2	6.122	50.8	1.27	None	2280	7.89
280	2050F 2	6.147	100	2.50	None	3170	5.68
230	2040F 2	7.368	44.7	1.12	None	2380	9.21
230	2050F 2	7.598	87.0	2.18	None	3300	6.64
190	2050F 2	9.119	76.5	1.91	None	3700	7.17
155	2050F 2	11.08	63.2	1.58	None	4020	8.09
155	2060F 2	11.26	110	2.75	None	6500	5.00
125	2050F 2	13.50	52.1	1.30	None	4370	9.23
125	2060F 2	13.72	90.7	2.27	None	6500	6.20
100	2050F 2	16.65	42.3	1.06	None	4370	11.53
100	2060F 2	17.19	69.8	1.75	None	6500	7.75
100	2070F 2	17.33	102	2.55	None	8500	5.93
84	2060F 2	21.13	59.3	1.48	None	6500	9.23
84	2070F 2	20.54	84.8	2.12	None	8500	7.06
84	2080F 2	20.98	117	2.93	None	10200	5.88
68	2060F 2	25.63	49.0	1.23	None	6500	11.40
68	2070F 2	25.12	68.0	1.70	None	8500	8.72
68	2080F 2	25.17	96.7	2.42	None	11000	6.74
56	2070F 2	31.08	53.1	1.33	None	8500	10.59
56	2080F 2	31.15	77.7	1.94	None	11000	8.18
45	2070F 3	37.83	46.2	1.16	None	8500	13.18
45	2080F 3	38.88	63.7	1.59	None	11000	10.18
45	2090F 3	39.51	98.7	2.47	None	14000	8.00
37	2080F 3	47.23	53.9	1.35	None	11000	12.38
37	2090F 3	48.23	86.3	2.16	None	14000	9.73
37	2100F 3	48.39	119	2.98	None	17000	8.01
30	2080F 3	57.56	44.9	1.12	None	11000	15.27
30	2090F 3	57.53	72.3	1.81	None	14000	12.00
30	2100F 3	57.29	102	2.55	None	17000	9.88
25	2090F 3	69.86	59.8	1.50	None	14000	14.40
25	2100F 3	71.64	81.6	2.04	None	17000	11.86
20	2090F 3	85.18	49.1	1.23	None	14000	18.00
20	2100F 3	88.36	66.2	1.66	None	17000	14.82
20	2110F 3	86.02	101	2.53	None	18500	13.62
16.5	2090F 3	103.4	40.4	1.01	None	14000	21.82
16.5	2100F 3	104.6	56.0	1.40	None	17000	17.97
16.5	2110F 3	104.9	82.5	2.06	None	18500	16.51
16.5	2120F 3	107.0	108	2.70	None	19000	16.08
13.5	2100F 3	133.8	43.8	1.10	None	17000	21.96
13.5	2110F 3	128.2	65.1	1.63	None	18500	20.18
13.5	2120F 3	128.9	89.7	2.24	None	19000	19.65
11.0	2110F 3	155.7	53.8	1.35	None	18500	24.77
11.0	2120F 3	158.2	73.2	1.83	None	19000	24.11
11.0	2130F 3	154.8	93.6	2.34	None	22500	20.36
9.0	2110F 4	192.9	45.3	1.13	None	18500	30.27
9.0	2120F 4	197.7	58.6	1.47	None	19000	29.47
9.0	2130F 4	199.0	81.0	2.03	None	22500	24.89
7.5	2120F 4	240.1	48.3	1.21	None	19000	35.37
7.5	2130F 4	237.4	67.0	1.68	None	22500	29.87
6.0	2130F 4	288.4	57.8	1.45	None	22500	37.33
5.0	2130F 4	351.4	47.4	1.19	None	22500	44.80

Motors are available from Regal Rexnord™ or Rexnord™ distributors.

40 HP/324T Motor

Energy Efficient Motor

Falk™ Part No. 2918115 TEFC, 1750 rpm 230/460 Volts, 3 Phase, 60 Hz, NEMA B, 1.15 Service Factor

Premium Efficiency Motor

Falk Part No. 2918135 TEFC, 1750 rpm 230/460 Volts, 3 Phase, 60 Hz, NEMA B, 1.15 Service Factor

Motors meeting other specifications are available upon request.

① Drive selections found in the Quick Selection Tables are based on an ambient temperature of 80°F (27°C) at sea level (0 to 2500 ft.). If the environmental factors differ for your specific application, the application-adjusted thermal rating must be calculated to verify the drive selection. See the Quick Selection example on page 11 and the application-adjusted thermal rating procedure on page 41.

② Published values of overhung load and sprocket pitch diameter are for loads applied one shaft diameter from the seal cage with a service factor of unity. Where overhung load is proportional to torque (i.e. pinion, sprocket or sheave applications) adjustment to the published values must be made based on the minimum required service factor. Refer to page 47 for additional information.

Quick Selection Tables

50 HP/1750 RPM/326T Motor ①

Approx. L.S. Shaft RPM	Drive Size & Reduction	Exact Ratio	HP Rating	Service Factor	Minimum Cooling Required	L.S. Shaft OHL Capacity (lb) ②	Minimum L.S. Shaft Sprocket Pitch Dia (in) ②
1170	2040F 2	1.465	57.6	1.15	None	2030	2.65
1170	2050F 2	1.476	115	2.30	None	2420	2.23
950	2040F 2	1.820	50.8	1.02	None	2040	3.25
950	2050F 2	1.822	87.5	1.75	None	2450	2.71
860	2040F 2	2.057	50.8	1.02	None	2150	3.41
860	2050F 2	2.028	115	2.30	None	2320	3.16
780	2040F 2	2.191	50.1	1.00	None	2200	3.67
780	2050F 2	2.252	90.3	1.81	None	2660	3.04
780	2060F 2	2.295	149	2.98	None	4670	1.73
700	2050F 2	2.504	102	2.04	None	2530	3.56
700	2060F 2	2.537	149	2.98	None	4840	1.86
640	2050F 2	2.702	79.2	1.58	None	2580	3.82
640	2060F 2	2.827	142	2.84	None	5020	1.96
575	2050F 2	3.095	90.3	1.81	None	2580	4.25
575	2060F 2	3.126	142	2.84	None	5020	2.18
520	2050F 2	3.283	68.0	1.36	None	2730	4.44
520	2060F 2	3.400	128	2.56	None	5450	2.22
470	2050F 2	3.714	79.2	1.58	None	2730	4.91
470	2060F 2	3.759	128	2.56	None	5450	2.46
420	2050F 2	4.001	56.7	1.13	None	2730	5.49
420	2060F 2	4.130	114	2.28	None	5450	2.75
380	2050F 2	4.512	68.0	1.36	None	3140	5.28
380	2060F 2	4.567	114	2.28	None	5750	2.88
350	2050F 2	4.980	114	2.28	None	3120	5.77
280	2050F 2	6.147	100	2.00	None	3170	7.10
280	2060F 2	6.256	149	2.98	None	5240	4.29
230	2050F 2	7.598	87.0	1.74	None	3300	8.30
230	2060F 2	7.708	142	2.84	None	5770	4.75
190	2050F 2	9.119	76.5	1.53	None	3700	8.96
190	2060F 2	9.269	128	2.56	None	6140	5.40
155	2050F 2	11.08	63.2	1.26	None	4020	10.11
155	2060F 2	11.26	110	2.20	None	6500	6.25
125	2050F 2	13.50	52.1	1.04	None	4370	11.53
125	2060F 2	13.72	90.7	1.81	None	6500	7.75
125	2070F 2	13.50	131	2.62	None	8500	5.93
100	2060F 2	17.19	69.8	1.40	None	6500	9.69
100	2070F 2	17.33	102	2.04	None	8500	7.41
100	2080F 2	17.34	149	2.98	None	7480	8.42
84	2060F 2	21.13	59.3	1.19	None	6500	11.54
84	2070F 2	20.54	84.8	1.70	None	8500	8.82
84	2080F 2	20.98	117	2.34	None	10200	7.35
68	2070F 2	25.12	68.0	1.36	None	8500	10.90
68	2080F 2	25.17	96.7	1.93	None	11000	8.42
56	2070F 2	31.08	53.1	1.06	None	8500	13.24
56	2080F 2	31.15	77.7	1.55	None	11000	10.23
56	2090F 2	31.15	133	2.66	None	14000	8.04
45	2080F 3	38.88	63.7	1.27	None	11000	12.73
45	2090F 3	39.51	98.7	1.97	None	14000	10.00
45	2100F 3	40.24	135	2.70	None	17000	8.24
37	2080F 3	47.23	53.9	1.08	None	11000	15.48
37	2090F 3	48.23	86.3	1.73	None	14000	12.16
37	2100F 3	48.39	119	2.38	None	17000	10.02
30	2090F 3	57.53	72.3	1.45	None	14000	15.00
30	2100F 3	57.29	102	2.04	None	17000	12.35
30	2110F 3	56.56	145	2.90	None	18500	11.35
25	2090F 3	69.86	59.8	1.20	None	14000	18.00
25	2100F 3	71.64	81.6	1.63	None	17000	14.82
25	2110F 3	68.94	125	2.50	None	18500	13.62
20	2100F 3	88.36	66.2	1.32	None	17000	18.53
20	2110F 3	86.02	101	2.02	None	18500	17.03
20	2120F 3	88.15	131	2.62	None	19000	16.58
16.5	2100F 3	104.6	56.0	1.12	None	17000	22.46
16.5	2110F 3	104.9	82.5	1.65	None	18500	20.64
16.5	2120F 3	107.0	108	2.16	None	19000	20.10
13.5	2110F 3	128.2	65.1	1.30	None	18500	25.23
13.5	2120F 3	128.9	89.7	1.79	None	19000	24.56
13.5	2130F 3	128.5	127	2.54	None	22500	20.74
11.0	2110F 3	155.7	53.8	1.08	None	18500	30.96
11.0	2120F 3	158.2	73.2	1.46	None	19000	30.14
11.0	2130F 3	154.8	93.6	1.87	None	22500	25.45
9.0	2120F 4	197.7	58.6	1.17	None	19000	36.84
9.0	2130F 4	199.0	81.0	1.62	None	22500	31.11
7.5	2130F 4	237.4	67.0	1.34	None	22500	37.33
6.0	2130F 4	288.4	57.8	1.16	None	22500	46.67

Motors are available from Regal Rexnord™ or Rexnord™ distributors.

50 HP/326T Motor

Energy Efficient Motor

Falk™ Part No. 2918116 TEFC, 1750 rpm 230/460 Volts, 3 Phase, 60 Hz, NEMA B, 1.15 Service Factor

Premium Efficiency Motor

Falk Part No. 2918136 TEFC, 1750 rpm 230/460 Volts, 3 Phase, 60 Hz, NEMA B, 1.15 Service Factor

Motors meeting other specifications are available upon request.

① Drive selections found in the Quick Selection Tables are based on an ambient temperature of 80°F (27°C) at sea level (0 to 2500 ft.). If the environmental factors differ for your specific application, the application-adjusted thermal rating must be calculated to verify the drive selection. See the Quick Selection example on page 11 and the application-adjusted thermal rating procedure on page 41.

② Published values of overhung load and sprocket pitch diameter are for loads applied one shaft diameter from the seal cage with a service factor of unity. Where overhung load is proportional to torque (i.e. pinion, sprocket or sheave applications) adjustment to the published values must be made based on the minimum required service factor. Refer to page 47 for additional information.

Quick Selection Tables

60 HP/1750 RPM/364T Motor ①

Approx. L.S. Shaft RPM	Drive Size & Reduction	Exact Ratio	HP Rating	Service Factor	Minimum Cooling Required	L.S. Shaft OHL Capacity (lb) ②	Minimum L.S. Shaft Sprocket Pitch Dia (in) ②
1170	2050F_2	1.476	115	1.92	None	2420	2.67
950	2050F_2	1.822	87.5	1.46	None	2450	3.25
950	2060F_2	1.833	172	2.87	None	4420	1.80
860	2050F_2	2.028	115	1.92	None	2320	3.79
860	2060F_2	2.027	172	2.87	None	4580	1.92
780	2050F_2	2.252	90.3	1.51	None	2660	3.64
780	2060F_2	2.295	149	2.48	None	4670	2.08
700	2050F_2	2.504	102	1.70	None	2530	4.27
700	2060F_2	2.537	149	2.48	None	4840	2.23
640	2050F_2	2.702	79.2	1.32	None	2580	4.58
640	2060F_2	2.827	142	2.37	None	5020	2.35
575	2050F_2	3.095	90.3	1.51	None	2580	5.10
575	2060F_2	3.126	142	2.37	None	5020	2.62
520	2050F_2	3.283	68.0	1.13	None	2730	5.33
520	2060F_2	3.400	128	2.13	None	5450	2.67
470	2050F_2	3.714	79.2	1.32	None	2730	5.89
470	2060F_2	3.759	128	2.13	None	5450	2.95
420	2060F_2	4.130	114	1.90	None	5450	3.30
420	2070F_2	3.954	164	2.73	None	6280	2.87
380	2050F_2	4.512	68.0	1.13	None	3140	6.34
380	2060F_2	4.567	114	1.90	None	5750	3.46
380	2070F_2	4.573	164	2.73	None	6690	2.97
350	2060F_2	4.998	172	2.87	Shaft Fan	5110	4.23
280	2060F_2	6.256	149	2.48	Shaft Fan	5240	5.15
230	2060F_2	7.708	142	2.37	Shaft Fan	5770	5.70
190	2060F_2	9.269	128	2.13	Shaft Fan	6140	6.48
155	2060F_2	11.26	110	1.83	Shaft Fan	6500	7.50
155	2070F_2	11.08	159	2.65	None	8210	5.94
125	2060F_2	13.72	90.7	1.51	Shaft Fan	6500	9.30
125	2070F_2	13.50	131	2.18	None	8500	7.12
100	2060F_2	17.19	69.8	1.16	Shaft Fan	6500	11.63
100	2070F_2	17.33	102	1.70	None	8500	8.89
100	2080F_2	17.34	149	2.48	None	7480	10.11
84	2070F_2	20.54	84.8	1.41	None	8500	10.59
84	2080F_2	20.98	117	1.95	None	10200	8.82
68	2070F_2	25.12	68.0	1.13	None	8500	13.08
68	2080F_2	25.17	96.7	1.61	None	11000	10.11
68	2090F_2	25.66	155	2.58	None	14000	7.94
56	2080F_2	31.15	77.7	1.30	None	11000	12.27
56	2090F_2	31.15	133	2.22	None	14000	9.64
45	2080F_3	38.88	63.7	1.06	None	11000	15.27
45	2090F_3	39.51	98.7	1.65	None	14000	12.00
45	2100F_3	40.24	135	2.25	None	17000	9.88
37	2090F_3	48.23	86.3	1.44	None	14000	14.59
37	2100F_3	48.39	119	1.98	None	17000	12.02
37	2110F_3	46.56	168	2.80	None	18500	11.04
30	2090F_3	57.53	72.3	1.20	None	14000	18.00
30	2100F_3	57.29	102	1.70	None	17000	14.82
30	2110F_3	56.56	145	2.42	None	18500	13.62
25	2090F_3	69.86	59.8	1.00	None	14000	21.60
25	2100F_3	71.64	81.6	1.36	None	17000	17.79
25	2110F_3	68.94	125	2.08	None	18500	16.35
25	2120F_3	68.05	169	2.82	None	19000	15.92
20	2100F_3	88.36	66.2	1.10	None	17000	22.24
20	2110F_3	86.02	101	1.68	None	18500	20.43
20	2120F_3	88.15	131	2.18	None	19000	19.89
16.5	2110F_3	104.9	82.5	1.38	None	18500	24.77
16.5	2120F_3	107.0	108	1.80	None	19000	24.11
16.5	2130F_3	105.9	150	2.50	None	22500	20.36
13.5	2110F_3	128.2	65.1	1.09	None	18500	30.27
13.5	2120F_3	128.9	89.7	1.50	None	19000	29.47
13.5	2130F_3	128.5	127	2.12	None	22500	24.89
11.0	2120F_3	158.2	73.2	1.22	None	19000	36.17
11.0	2130F_3	154.8	93.6	1.56	None	22500	30.55
9.0	2130F_4	199.0	81.0	1.35	None	22500	37.33
7.5	2130F_4	237.4	67.0	1.12	None	22500	44.80

Motors are available from Regal Rexnord™ or Rexnord™ distributors.

60 HP/364T Motor

Energy Efficient Motor

Falk™ Part No. 2918117 TEFC, 1750 rpm 230/460 Volts, 3 Phase, 60 Hz, NEMA B, 1.15 Service Factor

Premium Efficiency Motor

Falk Part No. 2918137 TEFC, 1750 rpm 230/460 Volts, 3 Phase, 60 Hz, NEMA B, 1.15 Service Factor

Motors meeting other specifications are available upon request.

① Drive selections found in the Quick Selection Tables are based on an ambient temperature of 80°F (27°C) at sea level (0 to 2500 ft.). If the environmental factors differ for your specific application, the application-adjusted thermal rating must be calculated to verify the drive selection. See the Quick Selection example on page 11 and the application-adjusted thermal rating procedure on page 41.

② Published values of overhung load and sprocket pitch diameter are for loads applied one shaft diameter from the seal cage with a service factor of unity. Where overhung load is proportional to torque (i.e. pinion, sprocket or sheave applications) adjustment to the published values must be made based on the minimum required service factor. Refer to page 47 for additional information.

Quick Selection Tables

75 HP/1750 RPM/365T Motor ①

Approx. L.S. Shaft RPM	Drive Size & Reduction	Exact Ratio	HP Rating	Service Factor	Minimum Cooling Required	L.S. Shaft OHL Capacity (lb) ②	Minimum L.S. Shaft Sprocket Pitch Dia (in) ②
1170	2060F_2	1.548	190	2.53	None	4360	1.85
950	2060F_2	1.833	172	2.29	None	4420	2.25
860	2060F_2	2.027	172	2.29	None	4580	2.40
780	2060F_2	2.295	149	1.99	None	4670	2.59
700	2060F_2	2.537	149	1.99	None	4840	2.79
640	2060F_2	2.827	142	1.89	None	5020	2.94
575	2060F_2	3.126	142	1.89	None	5020	3.27
520	2060F_2	3.400	128	1.71	None	5450	3.33
520	2070F_2	3.211	193	2.57	None	6280	2.89
470	2060F_2	3.759	128	1.71	None	5450	3.69
470	2070F_2	3.713	193	2.57	None	6280	3.20
420	2060F_2	4.130	114	1.52	None	5450	4.13
420	2070F_2	3.954	164	2.19	None	6280	3.58
380	2060F_2	4.567	114	1.52	None	5750	4.32
380	2070F_2	4.573	164	2.19	None	6690	3.72
350	2060F_2	4.998	172	2.29	Shaft Fan	5110	5.28
280	2060F_2	6.256	149	1.99	Shaft Fan	5240	6.44
230	2060F_2	7.708	142	1.89	Shaft Fan	5770	7.12
190	2060F_2	9.269	128	1.71	Shaft Fan	6140	8.10
190	2070F_2	8.996	193	2.57	None	7570	6.57
155	2060F_2	11.26	110	1.47	Shaft Fan	6500	9.38
155	2070F_2	11.08	159	2.12	None	8210	7.43
125	2060F_2	13.72	90.7	1.21	Shaft Fan	6500	11.63
125	2070F_2	13.50	131	1.75	Shaft Fan	8500	8.89
125	2080F_2	13.67	189	2.52	None	7480	10.11
100	2070F_2	17.33	102	1.36	Shaft Fan	8500	11.12
100	2080F_2	17.34	149	1.99	None	7480	12.63
84	2070F_2	20.54	84.8	1.13	Shaft Fan	8500	13.24
84	2080F_2	20.98	117	1.56	None	10200	11.03
84	2090F_2	21.01	188	2.51	Shaft Fan	14000	8.04
68	2080F_2	25.17	96.7	1.29	None	11000	12.63
68	2090F_2	25.66	155	2.07	Shaft Fan	14000	9.93
56	2080F_2	31.15	77.7	1.04	None	11000	15.34
56	2090F_2	31.15	133	1.77	Shaft Fan	14000	12.05
56	2100F_2	31.21	183	2.44	Shaft Fan	17000	9.93
45	2090F_3	39.51	98.7	1.32	None	14000	15.00
45	2100F_3	40.24	135	1.80	None	17000	12.35
45	2110F_3	38.38	196	2.61	None	18500	12.50
37	2090F_3	48.23	86.3	1.15	None	14000	18.24
37	2100F_3	48.39	119	1.59	None	17000	15.02
37	2110F_3	46.56	168	2.24	None	18500	13.81
30	2100F_3	57.29	102	1.36	None	17000	18.53
30	2110F_3	56.56	145	1.93	None	18500	17.03
30	2120F_3	57.02	202	2.69	None	19000	16.58
25	2100F_3	71.64	81.6	1.09	None	17000	22.24
25	2110F_3	68.94	125	1.67	None	18500	20.43
25	2120F_3	68.05	169	2.25	None	19000	19.89
20	2110F_3	86.02	101	1.35	None	18500	25.54
20	2120F_3	88.15	131	1.75	None	19000	24.87
20	2130F_3	81.72	200	2.67	None	22500	21.00
16.5	2110F_3	104.9	82.5	1.10	None	18500	30.96
16.5	2120F_3	107.0	108	1.44	None	19000	30.14
16.5	2130F_3	105.9	150	2.00	None	22500	25.45
13.5	2120F_3	128.9	89.7	1.20	None	19000	36.84
13.5	2130F_3	128.5	127	1.69	None	22500	31.11
11.0	2130F_3	154.8	93.6	1.25	None	22500	38.18
9.0	2130F_4	199.0	81.0	1.08	None	22500	46.67

Motors are available from Regal Rexnord™ or Rexnord™ distributors.

75 HP/365T Motor

Energy Efficient Motor

Falk™ Part No. 2918118 TEFC, 1750 rpm 230/460 Volts, 3 Phase, 60 Hz, NEMA B, 1.15 Service Factor

Premium Efficiency Motor

Falk Part No. 2918138 TEFC, 1750 rpm 230/460 Volts, 3 Phase, 60 Hz, NEMA B, 1.15 Service Factor

Motors meeting other specifications are available upon request.

- ① Drive selections found in the Quick Selection Tables are based on an ambient temperature of 80°F (27°C) at sea level (0 to 2500 ft.). If the environmental factors differ for your specific application, the application-adjusted thermal rating must be calculated to verify the drive selection. See the Quick Selection example on page 11 and the application-adjusted thermal rating procedure on page 41.
- ② Published values of overhung load and sprocket pitch diameter are for loads applied one shaft diameter from the seal cage with a service factor of unity. Where overhung load is proportional to torque (i.e. pinion, sprocket or sheave applications) adjustment to the published values must be made based on the minimum required service factor. Refer to page 47 for additional information.

Quick Selection Tables

100 HP/1750 RPM/405T Motor ^①

Approx. L.S. Shaft RPM	Drive Size & Reduction	Exact Ratio	HP Rating	Service Factor	Minimum Cooling Required	L.S. Shaft OHL Capacity (lb) ^②	Minimum L.S. Shaft Sprocket Pitch Dia (in) ^②
1170	2060F 2	1.548	190	1.90	Shaft Fan	4360	2.47
950	2060F 2	1.833	172	1.72	Shaft Fan	4420	3.00
950	2070F 2	1.783	282	2.82	Shaft Fan	4810	2.76
860	2060F 2	2.027	172	1.72	Shaft Fan	4580	3.20
860	2070F 2	2.062	282	2.82	Shaft Fan	4870	3.01
780	2060F 2	2.295	149	1.49	Shaft Fan	4670	3.46
780	2070F 2	2.197	279	2.79	Shaft Fan	5120	3.16
700	2060F 2	2.537	149	1.49	Shaft Fan	4840	3.72
700	2070F 2	2.541	279	2.79	Shaft Fan	5190	3.47
640	2060F 2	2.827	142	1.42	Shaft Fan	5020	3.92
640	2070F 2	2.683	239	2.39	Shaft Fan	5590	3.52
575	2060F 2	3.126	142	1.42	Shaft Fan	5020	4.37
575	2070F 2	3.103	239	2.39	Shaft Fan	5590	3.92
520	2060F 2	3.400	128	1.28	Shaft Fan	5450	4.45
520	2070F 2	3.211	193	1.93	Shaft Fan	6280	3.86
470	2060F 2	3.759	128	1.28	Shaft Fan	5450	4.92
470	2070F 2	3.713	193	1.93	Shaft Fan	6280	4.27
420	2060F 2	4.130	114	1.14	Shaft Fan	5450	5.50
420	2070F 2	3.954	164	1.64	Shaft Fan	6280	4.78
380	2060F 2	4.567	114	1.14	Shaft Fan	5750	5.77
380	2070F 2	4.573	164	1.64	Shaft Fan	6690	4.96
350	2060F 2	4.998	172	1.72	Shaft Fan	5110	7.05
350	2070F 2	4.996	255	2.55	Shaft Fan	6060	5.94
280	2060F 2	6.256	149	1.49	Shaft Fan	5240	8.59
280	2070F 2	6.155	258	2.58	Shaft Fan	6190	7.27
230	2060F 2	7.708	142	1.42	Shaft Fan	5770	9.49
230	2070F 2	7.517	231	2.31	Shaft Fan	6670	8.21
190	2060F 2	9.269	128	1.28	Shaft Fan	6140	10.80
190	2070F 2	8.996	193	1.93	Shaft Fan	7570	8.76
190	2080F 2	8.923	272	2.72	Shaft Fan	5460	12.15
155	2060F 2	11.26	110	1.10	Shaft Fan	6500	12.51
155	2070F 2	11.08	159	1.59	Shaft Fan	8210	9.90
155	2080F 2	11.13	231	2.31	Shaft Fan	6350	12.80
125	2070F 2	13.50	131	1.31	Shaft Fan	8500	11.86
125	2080F 2	13.67	189	1.89	Shaft Fan	7480	13.48
125	2090F 2	13.98	269	2.69	Shaft Fan	11900	8.47
100	2070F 2	17.33	102	1.02	Shaft Fan	8500	14.82
100	2080F 2	17.34	149	1.49	Shaft Fan	8900	16.84
100	2090F 2	16.78	235	2.35	Shaft Fan	13800	10.59
84	2080F 2	20.98	117	1.17	Shaft Fan	10200	14.71
84	2090F 2	21.01	188	1.88	Shaft Fan	14000	10.71
84	2100F 2	21.58	256	2.56	Shaft Fan	15500	9.68
68	2090F 2	25.66	155	1.55	Shaft Fan	14000	13.24
68	2100F 2	25.55	226	2.26	Shaft Fan	16900	10.96
56	2090F 2	31.15	133	1.33	Shaft Fan	14000	16.07
56	2100F 2	31.21	183	1.83	Shaft Fan	17000	13.24
56	2110F 2	31.12	263	2.63	None	18100	13.39
45	2100F 3	40.24	135	1.35	None	17000	16.47
45	2110F 3	38.38	196	1.96	None	18500	16.67
45	2120F 3	39.36	269	2.69	None	19000	14.74
37	2100F 3	48.39	119	1.19	None	17000	20.03
37	2110F 3	46.56	168	1.68	None	18500	18.41
37	2120F 3	47.71	239	2.39	None	19000	17.92
30	2100F 3	57.29	102	1.02	None	17000	24.71
30	2110F 3	56.56	145	1.45	None	18500	22.70
30	2120F 3	57.02	202	2.02	None	19000	22.11
30	2130F 3	57.30	276	2.76	None	22500	18.67
25	2110F 3	68.94	125	1.25	None	18500	27.24
25	2120F 3	68.05	169	1.69	None	19000	26.53
25	2130F 3	68.47	237	2.37	None	22500	22.40
20	2110F 3	86.02	101	1.01	None	18500	34.05
20	2120F 3	88.15	131	1.31	None	19000	33.16
20	2130F 3	81.72	200	2.00	None	22500	28.00
16.5	2120F 3	107.0	108	1.08	None	19000	40.19
16.5	2130F 3	105.9	150	1.50	None	22500	33.94
13.5	2130F 3	128.5	127	1.27	None	22500	41.48

Motors are available from Regal Rexnord™ or Rexnord™ distributors.

100 HP/405T Motor

Energy Efficient Motor

Falk™ Part No. 2918119 TEFC, 1750 rpm 230/460 Volts, 3 Phase, 60 Hz, NEMA B, 1.15 Service Factor

Premium Efficiency Motor

Falk Part No. 2918139 TEFC, 1750 rpm 230/460 Volts, 3 Phase, 60 Hz, NEMA B, 1.15 Service Factor

Motors meeting other specifications are available upon request.

① Drive selections found in the Quick Selection Tables are based on an ambient temperature of 80°F (27°C) at sea level (0 to 2500 ft.). If the environmental factors differ for your specific application, the application-adjusted thermal rating must be calculated to verify the drive selection. See the Quick Selection example on page 11 and the application-adjusted thermal rating procedure on page 41.

② Published values of overhung load and sprocket pitch diameter are for loads applied one shaft diameter from the seal cage with a service factor of unity. Where overhung load is proportional to torque (i.e. pinion, sprocket or sheave applications) adjustment to the published values must be made based on the minimum required service factor. Refer to page 47 for additional information.

Quick Selection Tables

125 HP/1750 RPM/444T Motor ①

Approx. L.S. Shaft RPM	Drive Size & Reduction	Exact Ratio	HP Rating	Service Factor	Minimum Cooling Required	L.S. Shaft OHL Capacity (lb) ②	Minimum L.S. Shaft Sprocket Pitch Dia (in) ②
1170	2060F_2	1.548	190	1.52	Shaft Fan	4360	3.09
950	2060F_2	1.833	172	1.38	Shaft Fan	4420	3.75
950	2070F_2	1.783	282	2.26	Shaft Fan	4810	3.45
860	2060F_2	2.027	172	1.38	Shaft Fan	4580	4.00
860	2070F_2	2.062	282	2.26	Shaft Fan	4870	3.76
780	2060F_2	2.295	149	1.19	Shaft Fan	4670	4.32
780	2070F_2	2.197	279	2.23	Shaft Fan	5120	3.94
700	2060F_2	2.537	149	1.19	Shaft Fan	4840	4.65
700	2070F_2	2.541	279	2.23	Shaft Fan	5190	4.34
640	2060F_2	2.827	142	1.14	Shaft Fan	5020	4.90
640	2070F_2	2.683	239	1.91	Shaft Fan	5590	4.40
575	2060F_2	3.126	142	1.14	Shaft Fan	5020	5.46
575	2070F_2	3.103	239	1.91	Shaft Fan	5590	4.90
520	2060F_2	3.400	128	1.02	Shaft Fan	5450	5.56
520	2070F_2	3.211	193	1.54	Shaft Fan	6280	4.82
470	2060F_2	3.759	128	1.02	Shaft Fan	5450	6.15
470	2070F_2	3.713	193	1.54	Shaft Fan	6280	5.34
420	2070F_2	3.954	164	1.31	Shaft Fan	6280	5.97
380	2070F_2	4.573	164	1.31	Shaft Fan	6690	6.20
380	2090F_2	4.763	330	2.64	None	11500	3.60
350	2060F_2	4.998	172	1.38	Electric Fan	5110	8.81
350	2070F_2	4.996	255	2.04	Shaft Fan	6060	7.43
350	2080F_2	5.161	370	2.96	Shaft Fan	4720	9.53
280	2060F_2	6.256	149	1.19	Electric Fan	5240	10.73
280	2070F_2	6.155	258	2.06	Shaft Fan	6190	9.09
280	2080F_2	6.290	362	2.90	Shaft Fan	4370	12.87
230	2060F_2	7.708	142	1.14	Electric Fan	5770	11.87
230	2070F_2	7.517	231	1.85	Shaft Fan	6670	10.27
230	2080F_2	7.638	324	2.59	Shaft Fan	4800	13.30
190	2060F_2	9.269	128	1.02	Electric Fan	6140	13.50
190	2070F_2	8.996	193	1.54	Shaft Fan	7570	10.95
190	2080F_2	8.923	272	2.18	Shaft Fan	5460	15.18
155	2070F_2	11.08	159	1.27	Shaft Fan	8210	12.38
155	2080F_2	11.13	231	1.85	Shaft Fan	6350	16.00
155	2090F_2	11.51	312	2.50	Shaft Fan	11000	9.24
125	2070F_2	13.50	131	1.05	Electric Fan	8500	14.82
125	2080F_2	13.67	189	1.51	Shaft Fan	7480	16.84
125	2090F_2	13.98	269	2.15	Shaft Fan	11900	10.59
125	2100F_2	14.01	359	2.87	Shaft Fan	13400	9.40
100	2080F_2	17.34	149	1.19	Shaft Fan	8900	21.06
100	2090F_2	16.78	235	1.88	Shaft Fan	11900	13.24
100	2100F_2	17.29	309	2.47	Shaft Fan	13400	11.75
84	2090F_2	21.01	188	1.50	Shaft Fan	14000	13.39
84	2100F_2	21.58	256	2.05	Shaft Fan	15500	12.10
68	2090F_2	25.66	155	1.24	Shaft Fan	14000	16.54
68	2100F_2	25.55	226	1.81	Shaft Fan	16900	13.71
68	2110F_2	25.39	307	2.46	None	16800	15.97
56	2090F_2	31.15	133	1.06	Shaft Fan	14000	20.09
56	2100F_2	31.21	183	1.46	Shaft Fan	17000	16.54
56	2110F_2	31.12	263	2.10	None	18100	16.74
56	2120F_2	31.89	353	2.82	None	19000	14.80
45	2100F_3	40.24	135	1.08	Shaft Fan	17000	20.59
45	2110F_3	38.38	196	1.57	None	18500	20.83
45	2120F_3	39.36	269	2.15	None	19000	18.42
45	2130F_3	39.60	332	2.66	None	22500	15.56
37	2110F_3	46.56	168	1.34	None	18500	23.01
37	2120F_3	47.71	239	1.91	None	19000	22.40
37	2130F_3	47.26	322	2.58	None	22500	18.92
30	2110F_3	56.56	145	1.16	None	18500	28.38
30	2120F_3	57.02	202	1.62	None	19000	27.63
30	2130F_3	57.30	276	2.21	None	22500	23.33
25	2110F_3	68.94	125	1.00	None	18500	34.05
25	2120F_3	68.05	169	1.35	None	19000	33.16
25	2130F_3	68.47	237	1.90	None	22500	28.00
20	2120F_3	88.15	131	1.05	None	19000	41.45
20	2130F_3	81.72	200	1.60	None	22500	35.00
16.5	2130F_3	105.9	150	1.20	None	22500	43.75
13.5	2130F_3	128.5	127	1.02	None	22500	53.85

Motors are available from Regal Rexnord™ or Rexnord™ distributors.

125 HP/444T Motor

Energy Efficient Motor

Falk™ Part No. 2918120 TEFC, 1750 rpm 460 Volts, 3 Phase, 60 Hz, NEMA B, 1.15 Service Factor

Premium Efficiency Motor

Falk Part No. 2918140 TEFC, 1750 rpm 460 Volts, 3 Phase, 60 Hz, NEMA B, 1.15 Service Factor

Motors meeting other specifications are available upon request.

① Drive selections found in the Quick Selection Tables are based on an ambient temperature of 80°F (27°C) at sea level (0 to 2500 ft.). If the environmental factors differ for your specific application, the application-adjusted thermal rating must be calculated to verify the drive selection. See the Quick Selection example on page 11 and the application-adjusted thermal rating procedure on page 41.

② Published values of overhung load and sprocket pitch diameter are for loads applied one shaft diameter from the seal cage with a service factor of unity. Where overhung load is proportional to torque (i.e. pinion, sprocket or sheave applications) adjustment to the published values must be made based on the minimum required service factor. Refer to page 47 for additional information.

Quick Selection Tables

150 HP/1750 RPM/445T Motor ①

Approx. L.S. Shaft RPM	Drive Size & Reduction	Exact Ratio	HP Rating	Service Factor	Minimum Cooling Required	L.S. Shaft OHL Capacity (lb) ②	Minimum L.S. Shaft Sprocket Pitch Dia (in) ②
1170	2060F_2	1.548	190	1.27	Shaft Fan	4360	3.71
950	2060F_2	1.833	172	1.15	Shaft Fan	4420	4.50
950	2070F_2	1.783	282	1.88	Shaft Fan	4810	4.14
860	2060F_2	2.027	172	1.15	Shaft Fan	4580	4.80
860	2070F_2	2.062	282	1.88	Shaft Fan	4870	4.51
780	2070F_2	2.197	279	1.86	Shaft Fan	5120	4.73
700	2070F_2	2.541	279	1.86	Shaft Fan	5190	5.20
640	2070F_2	2.683	239	1.59	Shaft Fan	5590	5.28
575	2070F_2	3.103	239	1.59	Shaft Fan	5590	5.88
520	2070F_2	3.211	193	1.29	Shaft Fan	6280	5.79
470	2070F_2	3.713	193	1.29	Shaft Fan	6280	6.40
420	2070F_2	3.954	164	1.09	Shaft Fan	6280	7.17
380	2070F_2	4.573	164	1.09	Shaft Fan	6690	7.43
350	2060F_2	4.998	172	1.15	Electric Fan	5110	10.57
350	2070F_2	4.996	255	1.70	Electric Fan	6060	8.91
350	2080F_2	5.161	370	2.47	Shaft Fan	4720	11.44
280	2070F_2	6.155	258	1.72	Electric Fan	6190	10.90
280	2080F_2	6.290	362	2.41	Shaft Fan	4370	15.45
230	2070F_2	7.517	231	1.54	Electric Fan	6670	12.32
230	2080F_2	7.638	324	2.16	Shaft Fan	5150	15.96
190	2070F_2	8.996	193	1.29	Electric Fan	7570	13.14
190	2080F_2	8.923	272	1.81	Shaft Fan	5460	18.22
190	2090F_2	9.257	386	2.57	Shaft Fan	10300	9.66
155	2070F_2	11.08	159	1.06	Electric Fan	8210	14.85
155	2080F_2	11.13	231	1.54	Shaft Fan	6350	19.20
155	2090F_2	11.51	312	2.08	Shaft Fan	11000	11.09
155	2100F_2	11.58	411	2.74	None	12600	9.68
125	2080F_2	13.67	189	1.26	Electric Fan	7480	20.21
125	2090F_2	13.98	269	1.79	Shaft Fan	11900	12.71
125	2100F_2	14.01	359	2.39	Shaft Fan	13400	11.28
100	2090F_2	16.78	235	1.57	Shaft Fan	11900	15.88
100	2100F_2	17.29	309	2.06	Shaft Fan	13400	14.10
100	2110F_2	17.01	433	2.89	None	13300	20.86
84	2090F_2	21.01	188	1.25	Shaft Fan	14000	16.07
84	2100F_2	21.58	256	1.71	Shaft Fan	15500	14.52
84	2110F_2	20.76	401	2.67	None	12400	18.15
68	2090F_2	25.66	155	1.03	Shaft Fan	14000	19.85
68	2100F_2	25.55	226	1.51	Shaft Fan	16900	16.45
68	2110F_2	25.39	307	2.05	None	16800	19.17
68	2120F_2	25.91	439	2.93	None	17500	15.88
56	2100F_2	31.21	183	1.22	Shaft Fan	17000	19.85
56	2110F_2	31.12	263	1.75	None	18100	20.09
56	2120F_2	31.89	353	2.35	None	19000	17.76
45	2110F_3	38.38	196	1.31	Shaft Fan	18500	25.00
45	2120F_3	39.36	269	1.79	None	19000	22.11
45	2130F_3	39.60	332	2.21	None	22500	18.67
37	2110F_3	46.56	168	1.12	Shaft Fan	18500	27.61
37	2120F_3	47.71	239	1.59	None	19000	26.88
37	2130F_3	47.26	322	2.15	None	22500	22.70
30	2120F_3	57.02	202	1.35	None	19000	33.16
30	2130F_3	57.30	276	1.84	None	22500	28.00
25	2120F_3	68.05	169	1.13	None	19000	39.79
25	2130F_3	68.47	237	1.58	None	22500	33.60
20	2130F_3	81.72	200	1.33	None	22500	42.00
16.5	2130F_3	105.9	150	1.00	None	22500	50.91

Motors are available from Regal Rexnord™ or Rexnord™ distributors.

150 HP/445T Motor

Energy Efficient Motor

Falk™ Part No. 2918121 TEFC, 1750 rpm 460 Volts, 3 Phase, 60 Hz, NEMA B, 1.15 Service Factor

Premium Efficiency Motor

Falk Part No. 2918141 TEFC, 1750 rpm 460 Volts, 3 Phase, 60 Hz, NEMA B, 1.15 Service Factor

Motors meeting other specifications are available upon request.

① Drive selections found in the Quick Selection Tables are based on an ambient temperature of 80°F (27°C) at sea level (0 to 2500 ft.). If the environmental factors differ for your specific application, the application-adjusted thermal rating must be calculated to verify the drive selection. See the Quick Selection example on page 11 and the application-adjusted thermal rating procedure on page 41.

② Published values of overhung load and sprocket pitch diameter are for loads applied one shaft diameter from the seal cage with a service factor of unity. Where overhung load is proportional to torque (i.e. pinion, sprocket or sheave applications) adjustment to the published values must be made based on the minimum required service factor. Refer to page 47 for additional information.

Quick Selection Tables

200 HP/1750 RPM ①

Approx. L.S. Shaft RPM	Drive Size & Reduction	Exact Ratio	HP Rating	Service Factor	Minimum Cooling Required	L.S. Shaft OHL Capacity (lb) ②	Minimum L.S. Shaft Sprocket Pitch Dia (in) ②
950	2070F_2	1.783	282	1.41	Electric Fan	4810	5.51
860	2070F_2	2.062	282	1.41	Electric Fan	4870	6.02
780	2070F_2	2.197	279	1.40	Electric Fan	5120	6.31
700	2070F_2	2.541	279	1.40	Electric Fan	5190	6.94
640	2070F_2	2.683	239	1.20	Electric Fan	5590	7.04
575	2070F_2	3.103	239	1.20	Electric Fan	5590	7.84
350	2070F_2	4.996	255	1.28	Electric Fan	6060	11.88
350	2080F_2	5.161	370	1.85	Electric Fan	4720	15.25
350	2090F_2	5.050	599	3.00	Shaft Fan	8620	8.35
280	2070F_2	6.155	258	1.29	Electric Fan	6190	14.54
280	2080F_2	6.290	362	1.81	Electric Fan	4370	20.59
280	2090F_2	6.050	538	2.69	Shaft Fan	8870	10.15
230	2070F_2	7.517	231	1.16	Electric Fan	6670	16.43
230	2080F_2	7.638	324	1.62	Electric Fan	5150	21.27
230	2090F_2	7.581	451	2.25	Shaft Fan	8870	12.35
190	2080F_2	8.923	272	1.36	Electric Fan	5460	24.29
190	2090F_2	9.257	386	1.93	Shaft Fan	10300	12.88
190	2100F_2	9.218	497	2.48	Shaft Fan	11900	11.15
155	2080F_2	11.13	231	1.16	Electric Fan	6350	25.60
155	2090F_2	11.51	312	1.56	Shaft Fan	11000	14.78
155	2100F_2	11.58	411	2.06	Shaft Fan	12600	12.90
125	2090F_2	13.98	269	1.35	Shaft Fan	11900	16.94
125	2100F_2	14.01	359	1.80	Shaft Fan	13400	15.04
125	2110F_2	13.94	519	2.60	Shaft Fan	9060	22.25
100	2090F_2	16.78	235	1.18	Shaft Fan	11900	21.18
100	2100F_2	17.29	309	1.55	Shaft Fan	13400	18.81
100	2110F_2	17.01	433	2.17	Shaft Fan	13300	27.81
84	2100F_2	21.58	256	1.28	Shaft Fan	15500	19.35
84	2110F_2	20.76	401	2.00	Shaft Fan	12400	24.19
84	2120F_2	21.12	510	2.55	None	16100	18.63
68	2100F_2	25.55	226	1.13	Shaft Fan	16900	21.93
68	2110F_2	25.39	307	1.54	Shaft Fan	16800	25.56
68	2120F_2	25.91	439	2.20	None	17500	21.18
68	2130F_2	25.36	582	2.91	None	22500	16.47
56	2110F_2	31.12	263	1.32	Shaft Fan	18100	26.79
56	2120F_2	31.89	353	1.77	None	19000	23.68
56	2130F_2	30.89	477	2.38	None	22500	20.00
45	2120F_3	39.36	269	1.35	Shaft Fan	19000	29.47
45	2130F_3	39.60	332	1.66	Shaft Fan	22500	24.89
37	2120F_3	47.71	239	1.20	Shaft Fan	19000	35.85
37	2130F_3	47.26	322	1.61	Shaft Fan	22500	30.27
30	2120F_3	57.02	202	1.01	Shaft Fan	19000	44.21
30	2130F_3	57.30	276	1.38	Shaft Fan	22500	37.33
25	2130F_3	68.47	237	1.19	Shaft Fan	22500	44.80
20	2130F_3	81.72	200	1.00	Shaft Fan	22500	56.00

Motors are available from Regal Rexnord™ or Rexnord™ distributors.

200 HP Motor

Energy Efficient Motor
Falk™ Part No. 2918122 TEFC,
1750 rpm 460 Volts, 3 Phase,
60 Hz, NEMA B, 445T, 1.15 Service
Factor

Premium Efficiency Motor
Falk Part No. 2918142 TEFC,
1750 rpm 460 Volts, 3 Phase,
60 Hz, NEMA B, 447T 1.15 Service
Factor

Motors meeting other
specifications are available
upon request.

- ① Drive selections found in the Quick Selection Tables are based on an ambient temperature of 80°F (27°C) at sea level (0 to 2500 ft.). If the environmental factors differ for your specific application, the application-adjusted thermal rating must be calculated to verify the drive selection. See the Quick Selection example on page 11 and the application-adjusted thermal rating procedure on page 41.
- ② Published values of overhung load and sprocket pitch diameter are for loads applied one shaft diameter from the seal cage with a service factor of unity. Where overhung load is proportional to torque (i.e. pinion, sprocket or sheave applications) adjustment to the published values must be made based on the minimum required service factor. Refer to page 47 for additional information.

How to Select/Horsepower & Torque Ratings Table Method

Selection Information

The Quick Selection Method may be used in place of the Horsepower & Torque Ratings Table Method if the application meets the following guidelines:

- 1750 rpm input
- Standard ratios for double, triple or quadruple reductions

NOTE: If you have an unusual application involving any of the following conditions, refer to pages 5 and 6.

- Excessive Overloads
- Reversing Service
- Brake-Equipped Applications
- Oversized Prime Movers
- Multi-Speed or Variable Speed Applications
- Excessive Ambient Temperatures
- Thermal Rating Application Factors
- Excessive Overhung Loads or Thrust Loads
- Product Modifications
- Non-Standard Motors or Prime Movers
- Non-Standard Motor Bracket Applications
- Non-Horizontal Mounting Positions

How to Select by Horsepower

1. Determine Service Factor or Load Classification Factor — See pages 7 and 8 or pages 9 and 10.
2. Calculate Equivalent Horsepower — Multiply the actual horsepower to be transmitted by the service factor.
3. Determine Drive Input Speed, Output Speed and Ratio.
4. Determine Drive Size — Select the nearest standard ratio from the Horsepower & Ratings Table starting on page 32. Opposite the high-speed shaft rpm, and the desired ratio and output speed, trace right to a horsepower capacity equal to or in excess of the equivalent horsepower calculated in Step 2. Read the drive size at the top of the column. When the required input speed falls between two tabulated input speeds of a drive with the same number of gear reductions, interpolate to determine gear drive rating.
5. Select Drive Configuration — Type FC or FZ. See pages 57-61.
6. Check Thermal Horsepower Ratings — See page 41 for instructions.
7. Check Overhung Loads and Thrust Capacity — See pages 47-54 for instructions.
8. Check Gear Drive Dimensions — pages 57-61.
9. Place the Order — See page 13 for How to Order.

Example:

Application: Belt conveyor, uniformly-fed, requires 13 hp at the head shaft.

Duty Cycle: 10 hours per day.

Driver: 17 hp multi-cylinder engine, 1600 rpm, coupling connected to drive.

Output: 115 rpm.

1. From Service Factor table, page 8 — motor-driven, uniformly-fed, belt conveyor, 10 hour service requires 1.25 service factor. From Table 2, page 7, convert this service factor for motor drive to 1.50 for engine drive.
2. Equivalent horsepower — $1.50 \times 13 = 19.5$ hp.
3. Input speed is 1600 rpm, output is 115 rpm, resulting in a required ratio of 13.9:1.
4. Refer to the Double Reduction — Horsepower selection table on page 33 for ratios 1.50 through 31.39.
 - A. Since 1600 rpm input is not listed, proportion the equivalent horsepower to the nearest published input speed: $1750 \div 1600 \times 19.5 = 21.3$ hp. In the 1750 high-speed shaft section opposite 13.95 ratio, trace right to 28.1 (nearest hp exceeding equivalent hp) and read drive size 2040 at the top of column.
5. For this example we will assume that a Type FC horizontal concentric shaft drive is desired.

6. Check the thermal rating on page 44. Since the thermal hp capacity of the 2040F2 exceeds the required hp (13 hp) at both 1750 and 1430 rpm, no additional cooling is required. (NOTE: for actual thermal capacity, interpolate between values at 1750 and 1430 rpm).
7. Refer to page 47 if a chain drive is required between the gear drive low-speed shaft and the conveyor. The drive overhung load capacity must be checked.
8. Dimensions and weights for this drive are listed on page 57.
9. Place the order for the gear drive per instructions on page 13.

How to Select by Torque

Simply follow the steps outlined in the horsepower method, substituting torque values for horsepower.

To check thermal capacity, convert the actual required torque to horsepower and check against the thermal rating. To convert, use the torque (lb-in) and speed (rpm) at low-speed shaft of the drive in the following formula:

$$HP = \frac{\text{torque} \times \text{output speed}}{63,000}$$

Example:

A drive to power a traveling water intake screen, 24 hours per day, is to deliver 30,000 pound-inches output torque when output shaft operates at 5 rpm. Source of power is a 3 hp, 1750 rpm motor.

1. From Service Factor table, page 8 — traveling water screen requires 1.25 service factor for 24 hour service.
2. Equivalent torque — $1.25 \times 30,000 = 37,500$ pound-inches.
3. Input speed is 1750 rpm, output is 5 rpm, resulting in a required ratio of 350:1.
4. Refer to the output Quadruple Reduction — Torque selection table on page 40. Closest standard ratio is 357.5. In the 1750 high-speed shaft section, opposite 357.5 ratio, trace right to 45.2 (x 1000) (nearest torque exceeding equivalent torque) and read drive size 2060 at top of column.
5. For this example we will assume that a Type FC horizontal concentric shaft drive is desired.
6. Check thermal rating, page 45. Convert torque to horsepower. The thermal rating is 18.6 for a size 2060F4 which exceeds the application hp is satisfactory.
$$\frac{30,000 \times 5}{63,000} = 2.38 \text{ HP}$$
7. Refer to page 47 to check overhung load capacity if a chain drive is required on the low-speed shaft.
8. Dimensions and weights for this drive are given on page 59.
9. Place the order for the drive per instructions on page 13.

Horsepower & Torque Ratings

Double Reduction

High-Speed Shaft RPM	Nominal Ratios ±4%	Approx. L.S. Shaft RPM	Horsepower ①						Torque ② ③					
			Drive Size						Drive Size					
			2040	2050	2060	2070	2080	2090	2040	2050	2060	2070	2080	2090
3500	1.50	2340	93.5	187	308	—	645	973	2.47	4.97	8.58	—	18.1	26.3
	1.84	1900	82.5	142	280	459	602	880	2.70	4.66	9.24	14.7	20.4	28.5
	2.03	1720	82.5	187	280	459	602	973	3.05	6.83	10.2	17.0	22.3	36.6
	2.25	1560	81.3	147	243	454	588	763	3.21	5.96	10.0	18.0	24.3	31.0
	2.49	1400	73.7	166	243	454	588	880	3.28	7.48	11.1	20.8	26.5	39.7
	2.76	1280	64.7	129	231	412	526	666	3.17	6.27	11.8	19.9	26.4	33.0
	3.05	1150	64.7	147	231	412	526	763	3.58	8.19	13.0	23.0	28.8	43.1
	3.38	1040	56.4	114	209	375	443	603	3.33	6.74	12.8	21.7	26.0	37.2
	3.74	940	56.4	129	209	375	443	666	3.76	8.62	14.1	25.1	28.3	45.9
	4.13	840	48.0	98.2	185	325	434	516	3.56	7.07	13.8	23.1	31.8	38.7
	4.57	760	48.0	114	185	322	434	603	4.02	9.26	15.2	26.5	34.6	51.7
	5.06	700	93.5	186	280	415	602	973	8.29	16.7	25.2	37.3	55.9	88.4
	6.20	560	82.5	163	243	419	588	874	9.09	18.0	27.4	46.4	66.6	95.2
	7.59	460	72.7	141	231	381	526	732	9.64	19.3	32.1	51.6	72.3	99.9
	9.30	380	62.0	126	209	337	443	627	10.2	20.7	34.9	54.6	71.2	104
	11.39	310	54.0	110	185	302	394	506	10.7	21.9	37.5	60.2	78.9	105
	13.95	250	45.7	96.5	160	256	338	437	11.4	23.5	39.5	62.2	83.2	110
	17.09	200	39.7	82.7	131	199	272	382	12.0	24.8	40.5	62.1	84.9	115
	20.93	168	35.3	68.1	111	166	225	305	12.6	25.2	42.2	61.4	85.0	115
	25.63	136	23.8	49.9	97.0	129	184	253	10.8	22.7	44.7	58.3	83.4	117
31.39	112	20.8	42.8	77.4	102	148	224	11.0	23.2	44.1	57.1	83.0	126	
2900	1.50	1900	82.0	164	270	—	566	853	2.61	5.26	9.08	—	19.2	27.9
	1.84	1560	72.3	125	245	402	527	771	2.86	4.95	9.76	15.6	21.6	30.2
	2.03	1400	72.3	164	245	402	527	853	3.23	7.23	10.8	18.0	23.5	38.7
	2.25	1280	71.3	129	213	398	515	669	3.39	6.31	10.6	19.0	25.7	32.8
	2.49	1150	64.6	145	213	398	515	771	3.47	7.89	11.7	22.0	28.0	41.9
	2.76	1040	56.7	113	203	361	461	584	3.35	6.63	12.5	21.0	28.0	35.0
	3.05	940	56.7	129	203	361	461	669	3.79	8.67	13.8	24.3	30.5	45.6
	3.38	840	49.4	99.6	183	320	388	528	3.52	7.10	13.5	22.3	27.5	39.3
	3.74	760	49.4	113	183	320	388	584	3.98	9.12	14.9	25.8	29.9	48.6
	4.13	700	42.0	86.1	162	269	380	453	3.76	7.48	14.5	23.1	33.6	41.0
	4.57	620	42.0	99.6	162	269	380	528	4.25	9.76	16.1	26.7	36.6	54.6
	5.06	560	82.0	163	245	364	527	853	8.78	17.6	26.6	39.5	59.1	93.6
	6.20	460	72.3	142	213	368	515	767	9.62	19.0	28.9	49.2	70.4	101
	7.59	380	63.7	124	203	334	461	642	10.2	20.5	34.0	54.5	76.5	106
	9.30	310	54.4	110	183	295	388	550	10.8	21.8	36.8	57.7	75.2	111
	11.39	250	47.4	96.6	162	259	345	444	11.4	23.2	39.6	62.3	83.4	111
	13.95	200	40.1	84.6	140	214	296	383	12.1	24.8	41.7	62.8	87.9	116
	17.09	168	34.8	69.6	111	165	238	335	12.7	25.2	41.5	62.1	89.6	122
	20.93	136	30.9	56.6	97.5	138	186	268	13.3	25.3	44.7	61.6	84.8	122
	25.63	112	20.8	43.7	80.7	109	154	221	11.4	24.0	44.9	59.5	84.2	123
31.39	90	18.2	37.6	65.5	85.6	125	196	11.6	24.6	45.1	57.8	84.6	133	
2400	1.50	1560	71.8	144	236	—	496	747	2.76	5.58	9.59	—	20.3	29.5
	1.84	1280	63.3	109	215	352	462	676	3.02	5.21	10.3	16.5	22.9	32.0
	2.03	1150	63.3	144	215	352	462	747	3.42	7.67	11.4	19.1	24.9	41.0
	2.25	1040	62.4	113	186	349	451	586	3.59	6.68	11.2	20.1	27.2	34.7
	2.49	940	56.6	127	186	349	451	676	3.68	8.35	12.4	23.3	29.6	44.4
	2.76	840	49.7	98.8	178	316	404	511	3.55	7.01	13.2	22.3	29.6	37.0
	3.05	760	49.7	113	178	316	404	586	4.01	9.18	14.6	25.7	32.2	48.3
	3.38	700	43.3	87.2	160	265	340	452	3.73	7.51	14.3	22.3	29.1	40.7
	3.74	620	43.3	98.8	160	265	340	511	4.21	9.63	15.8	25.8	31.7	51.4
	4.13	560	36.8	75.4	142	223	319	385	3.98	7.92	15.4	23.1	34.1	42.1
	4.57	510	36.8	87.2	142	223	319	452	4.50	10.3	17.0	26.8	37.1	56.5
	5.06	460	71.8	143	215	319	462	747	9.29	18.7	28.2	41.8	62.6	99.0
	6.20	380	63.3	125	186	322	451	671	10.2	20.2	30.5	52.0	74.5	107
	7.59	310	55.8	109	178	293	404	562	10.8	21.7	36.0	57.8	81.0	112
	9.30	250	47.6	96.5	160	259	340	481	11.4	23.1	38.9	61.2	79.6	117
	11.39	200	41.5	84.7	142	216	303	389	12.0	24.6	42.0	62.8	88.5	118
	13.95	168	35.1	71.0	123	178	257	336	12.8	25.2	44.3	63.1	92.2	123
	17.09	136	30.5	57.8	93.4	138	198	294	13.5	25.3	42.2	62.8	90.1	129
	20.93	112	26.1	47.0	81.0	116	157	234	13.6	25.4	44.9	62.5	86.5	129
	25.63	90	18.2	38.3	67.0	91.5	130	194	12.1	25.4	45.1	60.3	85.9	131
31.39	74	16.0	32.2	54.3	71.7	105	172	12.4	25.5	45.2	58.5	85.9	141	

- ① When selecting gear drives by HP method, check required HP (without service factor) against the application-adjusted thermal HP ratings. For ratings at speeds higher than 3500 RPM, refer to Factory.
- ② When selecting gear drives by torque method, convert required torque (without service factor) to HP and check against the application-adjusted thermal HP ratings. For ratings at speeds higher than 3500 RPM, refer to Factory.
- ③ Torque is in lb-in at low-speed shaft — multiply values listed by 1000.

Horsepower & Torque Ratings

Double Reduction — Horsepower

High-Speed Shaft RPM	Nominal Ratios ±4%	Approx. L.S. Shaft RPM	Drive Size ①									
			2040	2050	2060	2070	2080	2090	2100	2110	2120	2130
1750	1.50	1170	57.6	115	190	—	397	599	—	—	—	—
	1.84	950	50.8	87.5	172	282	370	542	—	—	—	—
	2.03	860	50.8	115	172	282	370	599	—	—	—	—
	2.25	780	50.1	90.3	149	279	362	470	—	—	—	—
	2.49	700	45.4	102	149	279	362	542	—	—	—	—
	2.76	640	39.8	79.2	142	239	324	410	—	—	—	—
	3.05	575	39.8	90.3	142	239	324	470	—	—	—	—
	3.38	520	34.7	68.0	128	193	272	330	—	—	—	—
	3.74	470	34.7	79.2	128	193	272	410	—	—	—	—
	4.13	420	28.5	56.7	114	164	233	281	—	—	—	—
	4.57	380	28.5	68.0	114	164	233	330	—	—	—	—
	5.06	350	57.6	114	172	255	370	599	762	—	—	—
	6.20	280	50.8	100	149	258	362	538	647	—	—	—
	7.59	230	44.7	87.0	142	231	324	451	568	—	—	—
	9.30	190	38.2	76.5	128	193	272	386	497	750	—	—
	11.39	155	33.3	63.2	110	159	231	312	411	627	869	1050
	13.95	125	28.1	52.1	90.7	131	189	269	359	519	753	927
	17.09	100	23.3	42.3	69.8	102	149	235	309	433	629	794
20.93	84	19.3	34.4	59.3	84.8	117	188	256	401	510	635	
25.63	68	14.6	28.0	49.0	68.0	96.7	155	226	307	439	582	
31.39	56	12.8	23.5	39.7	53.1	77.7	133	183	263	353	477	
1430	1.50	950	50.0	98.5	157	—	345	520	—	—	—	—
	1.84	780	44.1	76.0	149	245	322	470	—	—	—	—
	2.03	700	44.1	98.5	149	245	322	520	—	—	—	—
	2.25	640	43.5	75.2	130	228	314	408	—	—	—	—
	2.49	575	39.4	88.1	130	228	314	470	—	—	—	—
	2.76	520	33.9	67.8	124	195	281	356	—	—	—	—
	3.05	470	33.9	75.2	124	195	281	408	—	—	—	—
	3.38	420	29.5	56.4	111	160	237	269	—	—	—	—
	3.74	380	29.5	67.8	111	160	237	356	—	—	—	—
	4.13	350	23.5	46.9	96.1	136	194	230	—	—	—	—
	4.57	310	23.5	56.4	96.1	136	194	269	—	—	—	—
	5.06	280	50.0	98.5	149	222	322	520	661	—	—	—
	6.20	230	44.1	86.8	130	224	314	467	562	—	—	—
	7.59	190	38.8	75.1	124	190	274	391	493	—	—	—
	9.30	155	33.1	62.8	109	160	235	335	432	651	—	—
	11.39	125	28.9	51.9	90.4	130	190	269	357	513	754	912
	13.95	100	23.3	42.7	74.4	107	155	230	312	424	635	757
	17.09	84	19.2	34.7	57.7	84.0	123	199	265	357	514	649
20.93	68	15.9	28.1	48.6	69.3	96.9	161	213	334	423	520	
25.63	56	12.7	22.9	40.1	56.1	79.8	132	186	255	360	497	
31.39	45	10.9	19.2	32.4	43.7	64.0	109	152	218	293	397	
1170	1.50	780	43.0	82.2	129	—	287	442	—	—	—	—
	1.84	640	38.3	66.0	130	213	279	396	—	—	—	—
	2.03	575	38.3	82.2	130	213	279	442	—	—	—	—
	2.25	520	37.8	62.4	113	188	273	341	—	—	—	—
	2.49	470	34.2	73.3	113	188	273	396	—	—	—	—
	2.76	420	28.1	56.2	107	163	244	295	—	—	—	—
	3.05	380	28.1	62.4	107	163	237	341	—	—	—	—
	3.38	350	24.4	46.6	94.1	133	206	224	—	—	—	—
	3.74	310	24.4	56.2	94.1	133	205	295	—	—	—	—
	4.13	280	19.4	38.7	79.6	113	161	188	—	—	—	—
	4.57	255	19.4	46.5	79.6	113	161	224	—	—	—	—
	5.06	230	43.0	82.2	130	193	279	442	575	—	—	—
	6.20	190	38.3	73.3	113	188	272	396	488	—	—	—
	7.59	155	33.7	61.7	107	156	225	340	428	—	—	—
	9.30	125	28.1	51.6	89.8	131	194	291	375	558	—	—
	11.39	100	23.9	42.6	74.2	107	156	224	310	420	617	748
	13.95	84	19.1	35.0	61.0	88.1	127	188	271	352	519	620
	17.09	68	15.7	28.4	47.7	68.9	101	165	221	298	421	533
20.93	56	13.1	23.1	39.8	56.7	80.1	132	177	277	352	434	
25.63	45	10.5	18.8	32.8	46.2	65.9	108	152	211	296	414	
31.39	37	8.96	15.8	26.5	36.0	52.7	89.4	125	180	241	329	

① When selecting gear drives by HP method, check required HP (without service factor) against the application-adjusted thermal HP ratings. For ratings at speeds higher than 3500 RPM, refer to Factory.

Horsepower & Torque Ratings

Double Reduction — Torque

High-Speed Shaft RPM	Nominal Ratios ±4%	Approx. L.S. Shaft RPM	Drive Size ① ②									
			2040	2050	2060	2070	2080	2090	2100	2110	2120	2130
1750	1.50	1170	3.04	6.11	10.6	—	22.3	32.4	—	—	—	—
	1.84	950	3.33	5.74	11.4	18.1	25.1	35.2	—	—	—	—
	2.03	860	3.76	8.40	12.6	20.9	27.4	45.1	—	—	—	—
	2.25	780	3.95	7.32	12.3	22.1	30.0	38.2	—	—	—	—
	2.49	700	4.05	9.19	13.6	25.5	32.6	48.8	—	—	—	—
	2.76	640	3.90	7.71	14.5	23.1	32.6	40.7	—	—	—	—
	3.05	575	4.41	10.1	16.0	26.7	35.5	53.1	—	—	—	—
	3.38	520	4.10	8.04	15.7	22.3	31.9	40.7	—	—	—	—
	3.74	470	4.63	10.6	17.3	25.8	34.8	56.5	—	—	—	—
	4.13	420	4.23	8.17	17.0	23.3	34.1	42.1	—	—	—	—
	4.57	380	4.78	11.0	18.7	27.0	37.2	56.6	—	—	—	—
	5.06	350	10.2	20.4	31.0	45.9	68.7	109	139	—	—	—
	6.20	280	11.2	22.1	33.6	57.2	82.0	117	149	—	—	—
	7.59	230	11.9	23.8	39.4	62.5	89.1	123	156	—	—	—
	9.30	190	12.6	25.1	42.7	62.5	87.4	129	165	256	—	—
	11.39	155	13.2	25.2	44.6	63.4	92.5	129	171	259	361	448
	13.95	125	14.0	25.3	44.8	63.7	93.0	135	181	260	380	481
	17.09	100	14.1	25.4	43.2	63.6	93.0	142	192	265	393	490
20.93	84	13.8	25.5	45.1	62.7	88.4	142	199	300	388	486	
25.63	68	13.3	25.5	45.2	61.5	87.6	143	208	281	409	531	
31.39	56	13.6	25.5	45.3	59.4	87.1	149	206	295	405	531	
1430	1.50	950	3.23	6.40	10.7	—	23.7	34.4	—	—	—	—
	1.84	780	3.54	6.10	12.0	19.2	26.8	37.3	—	—	—	—
	2.03	700	4.00	8.80	13.3	22.3	29.1	47.9	—	—	—	—
	2.25	640	4.20	7.46	13.1	22.1	31.8	40.6	—	—	—	—
	2.49	575	4.30	9.72	14.5	25.5	34.6	51.8	—	—	—	—
	2.76	520	4.07	8.07	15.4	23.1	34.6	43.2	—	—	—	—
	3.05	470	4.59	10.3	17.1	26.7	37.6	56.4	—	—	—	—
	3.38	420	4.26	8.16	16.6	22.6	34.1	40.6	—	—	—	—
	3.74	380	4.82	11.1	18.4	26.2	37.1	60.1	—	—	—	—
	4.13	350	4.27	8.27	17.5	23.7	34.8	42.2	—	—	—	—
	4.57	310	4.82	11.2	19.3	27.4	37.9	56.5	—	—	—	—
	5.06	280	10.9	21.6	32.8	48.9	73.2	116	148	—	—	—
	6.20	230	11.9	23.5	35.8	60.7	87.0	124	159	—	—	—
	7.59	190	12.6	25.1	42.1	62.9	92.2	131	166	—	—	—
	9.30	155	13.4	25.2	44.5	63.4	92.4	137	175	271	—	—
	11.39	125	14.0	25.3	44.8	63.4	93.1	136	182	259	383	476
	13.95	100	14.2	25.4	45.0	63.6	93.4	142	193	260	392	481
	17.09	84	14.2	25.5	43.7	64.1	94.0	147	202	268	393	490
20.93	68	13.9	25.5	45.2	62.7	89.6	149	202	306	394	487	
25.63	56	14.1	25.5	45.3	62.1	88.5	149	209	285	411	555	
31.39	45	14.1	25.5	45.2	59.8	87.8	150	209	299	412	540	
1170	1.50	780	3.39	6.53	10.8	—	24.1	35.8	—	—	—	—
	1.84	640	3.75	6.47	12.8	20.5	28.3	38.4	—	—	—	—
	2.03	575	4.24	8.98	14.2	23.7	30.9	49.7	—	—	—	—
	2.25	520	4.46	7.57	14.0	22.2	33.8	41.4	—	—	—	—
	2.49	470	4.56	9.88	15.4	25.7	36.8	53.4	—	—	—	—
	2.76	420	4.12	8.18	16.3	23.6	36.7	43.8	—	—	—	—
	3.05	380	4.65	10.4	18.0	27.2	38.8	57.6	—	—	—	—
	3.38	350	4.31	8.24	17.2	23.0	36.2	41.3	—	—	—	—
	3.74	310	4.87	11.2	19.0	26.6	39.2	60.8	—	—	—	—
	4.13	280	4.30	8.34	17.7	24.1	35.3	42.2	—	—	—	—
	4.57	255	4.86	11.3	19.6	27.8	38.4	57.5	—	—	—	—
	5.06	230	11.4	22.0	35.0	51.9	77.5	120	157	—	—	—
	6.20	190	12.6	24.3	38.1	62.3	92.1	129	169	—	—	—
	7.59	155	13.4	25.2	44.4	63.1	92.5	139	176	—	—	—
	9.30	125	13.9	25.3	44.8	63.5	93.2	145	186	284	—	—
	11.39	100	14.2	25.4	45.0	63.8	93.5	139	193	259	384	477
	13.95	84	14.3	25.4	45.1	64.0	93.5	142	204	264	391	482
	17.09	68	14.2	25.5	44.2	64.3	94.3	149	206	273	394	492
20.93	56	14.0	25.6	45.3	62.7	90.5	149	206	310	400	497	
25.63	45	14.3	25.6	45.3	62.5	89.3	149	209	288	413	565	
31.39	37	14.2	25.7	45.2	60.2	88.4	150	210	302	414	547	

① When selecting gear drives by torque method, convert required torque (without service factor) to HP and check against the application-adjusted thermal HP ratings. For ratings at speeds higher than 3500 RPM, refer to Factory.

② Torque is in lb-in at low-speed shaft — multiply values listed by 1000.

Horsepower & Torque Ratings

Double Reduction — Horsepower

High-Speed Shaft RPM	Nominal Ratios ±4%	Approx. L.S. Shaft RPM	Drive Size ①									
			2040	2050	2060	2070	2080	2090	2100	2110	2120	2130
870	1.50	580	32.6	62.4	98.2	—	213	329	—	—	—	—
	1.84	470	28.9	53.7	106	173	212	296	—	—	—	—
	2.03	430	28.9	62.4	106	173	212	329	—	—	—	—
	2.25	390	29.5	47.2	91.6	143	212	258	—	—	—	—
	2.49	350	27.8	55.6	91.6	143	212	296	—	—	—	—
	2.76	320	21.1	42.4	82.9	124	187	225	—	—	—	—
	3.05	290	21.1	47.2	82.9	124	179	258	—	—	—	—
	3.38	260	18.3	35.1	71.2	101	164	171	—	—	—	—
	3.74	235	18.3	42.1	71.2	101	154	225	—	—	—	—
	4.13	210	14.5	29.1	60.1	85.5	122	140	—	—	—	—
	4.57	190	14.5	34.8	60.0	85.5	122	171	—	—	—	—
	5.06	175	32.6	62.4	106	151	212	329	467	—	—	—
	6.20	140	29.1	55.6	91.6	142	204	296	397	—	—	—
	7.59	115	26.6	46.1	80.5	117	169	258	348	—	—	—
	9.30	95	21.1	38.5	67.1	98.2	145	221	305	421	—	—
	11.39	77	17.8	31.7	55.4	80.0	116	171	248	321	466	559
	13.95	62	14.2	26.1	45.5	65.8	95.0	140	206	268	397	470
	17.09	50	11.7	21.2	35.8	51.4	75.1	123	167	226	313	407
20.93	42	9.80	17.2	29.6	42.2	60.2	98.4	133	207	267	330	
25.63	34	7.83	14.0	24.4	34.7	49.4	80.7	114	159	221	313	
31.39	28	6.69	11.7	19.7	27.0	39.5	66.6	93.1	135	180	249	
720	1.50	470	27.2	52.2	82.4	—	177	276	—	—	—	—
	1.84	390	24.1	46.4	92.4	149	176	250	—	—	—	—
	2.03	350	24.1	52.2	92.4	149	176	276	—	—	—	—
	2.25	320	24.5	39.4	80.2	120	178	217	—	—	—	—
	2.49	290	24.1	46.4	80.2	120	178	250	—	—	—	—
	2.76	260	17.6	35.3	69.2	104	157	189	—	—	—	—
	3.05	235	17.6	39.4	69.2	104	149	217	—	—	—	—
	3.38	210	15.3	29.2	59.4	84.3	137	143	—	—	—	—
	3.74	190	15.3	35.0	59.4	84.3	128	189	—	—	—	—
	4.13	175	12.1	24.2	50.1	71.4	102	116	—	—	—	—
	4.57	155	12.1	28.9	49.8	71.4	102	143	—	—	—	—
	5.06	140	27.2	52.2	92.4	125	176	276	405	—	—	—
	6.20	115	24.2	46.3	80.2	118	169	250	347	—	—	—
	7.59	95	22.1	38.2	66.8	97.2	140	217	305	—	—	—
	9.30	77	17.6	31.9	55.7	81.5	120	183	258	354	—	—
	11.39	62	14.8	26.3	45.9	66.3	96.6	143	206	269	392	471
	13.95	50	11.8	21.6	37.7	54.5	78.8	116	171	224	333	395
	17.09	42	9.71	17.6	29.8	42.6	62.3	102	139	189	259	342
20.93	34	8.14	14.2	24.5	34.9	50.1	81.6	111	172	223	276	
25.63	28	6.49	11.6	20.2	28.8	41.1	66.9	94.1	133	183	262	
31.39	22	5.55	9.71	16.3	22.4	32.8	55.2	77.1	113	149	207	
580	1.50	390	22.1	42.5	67.2	—	142	226	—	—	—	—
	1.84	320	19.6	37.7	77.6	121	141	204	—	—	—	—
	2.03	290	19.6	42.5	77.6	121	141	226	—	—	—	—
	2.25	260	19.8	31.9	68.9	98.0	145	177	—	—	—	—
	2.49	235	19.5	37.7	68.9	98.0	145	204	—	—	—	—
	2.76	210	14.3	28.7	56.3	84.3	128	154	—	—	—	—
	3.05	190	14.3	31.9	56.3	84.3	121	177	—	—	—	—
	3.38	175	12.3	23.7	48.3	68.6	112	116	—	—	—	—
	3.74	155	12.3	28.3	48.3	68.6	104	154	—	—	—	—
	4.13	140	9.77	19.6	40.7	58.0	82.8	93.1	—	—	—	—
	4.57	130	9.77	23.3	40.3	58.0	82.8	116	—	—	—	—
	5.06	115	22.1	42.5	77.6	101	141	226	333	—	—	—
	6.20	95	19.7	37.3	66.3	95.7	137	204	285	—	—	—
	7.59	77	17.8	30.9	53.9	78.6	113	177	250	—	—	—
	9.30	62	14.3	25.8	44.9	65.8	97.1	148	208	290	—	—
	11.39	50	11.9	21.2	37.0	53.5	78.0	116	166	220	320	386
	13.95	42	9.51	17.4	30.4	44.0	63.6	93.1	138	183	272	323
	17.09	34	7.83	14.2	24.1	34.3	50.2	82.3	112	154	209	279
20.93	28	6.58	11.5	19.7	28.1	40.6	65.8	89.7	139	181	225	
25.63	22	5.23	9.34	16.3	23.3	33.3	54.0	75.9	108	148	213	
31.39	18	4.48	7.83	13.2	18.1	26.5	44.5	62.2	91.3	120	168	

① When selecting gear drives by HP method, check required HP (without service factor) against the application-adjusted thermal HP ratings. For ratings at speeds higher than 3500 RPM, refer to Factory.

Horsepower & Torque Ratings

Double Reduction — Torque

High-Speed Shaft RPM	Nominal Ratios ±4%	Approx. L.S. Shaft RPM	Drive Size ① ②									
			2040	2050	2060	2070	2080	2090	2100	2110	2120	2130
870	1.50	580	3.46	6.67	11.0	—	24.1	35.8	—	—	—	—
	1.84	470	3.81	7.08	14.1	22.3	29.0	38.6	—	—	—	—
	2.03	430	4.30	9.16	15.6	25.8	31.5	49.8	—	—	—	—
	2.25	390	4.68	7.70	15.2	22.8	35.3	42.2	—	—	—	—
	2.49	350	4.98	10.1	16.8	26.3	38.4	53.7	—	—	—	—
	2.76	320	4.16	8.30	17.0	24.1	37.8	44.9	—	—	—	—
	3.05	290	4.70	10.6	18.8	27.9	39.4	58.6	—	—	—	—
	3.38	260	4.35	8.34	17.5	23.5	38.7	42.4	—	—	—	—
	3.74	235	4.91	11.3	19.4	27.2	39.6	62.4	—	—	—	—
	4.13	210	4.33	8.43	18.0	24.5	35.9	42.2	—	—	—	—
	4.57	190	4.89	11.4	19.8	28.3	39.1	59.0	—	—	—	—
	5.06	175	11.6	22.5	38.4	54.6	79.2	120	172	—	—	—
	6.20	140	12.9	24.8	41.5	63.3	92.9	130	184	—	—	—
	7.59	115	14.2	25.4	44.9	63.7	93.5	142	193	—	—	—
	9.30	95	14.0	25.4	45.0	64.0	93.7	148	204	289	—	—
	11.39	77	14.2	25.4	45.2	64.2	93.5	143	208	266	390	480
	13.95	62	14.2	25.5	45.2	64.3	94.1	142	209	271	403	491
	17.09	50	14.3	25.6	44.6	64.5	94.3	149	209	278	394	505
20.93	42	14.1	25.6	45.3	62.8	91.4	150	208	311	408	508	
25.63	34	14.3	25.6	45.3	63.1	90.0	150	211	292	415	575	
31.39	28	14.3	25.6	45.2	60.8	89.1	150	210	304	416	557	
720	1.50	470	3.49	6.74	11.2	—	24.2	36.3	—	—	—	—
	1.84	390	3.84	7.40	14.8	23.3	29.1	39.4	—	—	—	—
	2.03	350	4.34	9.26	16.4	26.9	31.6	50.5	—	—	—	—
	2.25	320	4.70	7.76	16.1	23.1	35.8	42.9	—	—	—	—
	2.49	290	5.22	10.2	17.8	26.7	39.0	54.8	—	—	—	—
	2.76	260	4.19	8.35	17.1	24.4	38.4	45.6	—	—	—	—
	3.05	235	4.74	10.7	18.9	28.2	39.6	59.6	—	—	—	—
	3.38	210	4.39	8.39	17.7	23.7	39.1	42.9	—	—	—	—
	3.74	190	4.96	11.4	19.5	27.4	39.8	63.3	—	—	—	—
	4.13	175	4.36	8.47	18.1	24.7	36.3	42.3	—	—	—	—
	4.57	155	4.93	11.4	19.9	28.6	39.5	59.6	—	—	—	—
	5.06	140	11.7	22.7	40.4	54.6	79.5	122	180	—	—	—
	6.20	115	13.0	24.9	43.9	63.5	93.0	132	195	—	—	—
	7.59	95	14.2	25.4	45.1	63.9	93.6	144	204	—	—	—
	9.30	77	14.1	25.5	45.2	64.2	93.7	148	208	293	—	—
	11.39	62	14.3	25.5	45.2	64.3	94.0	144	209	270	396	489
	13.95	50	14.3	25.5	45.3	64.4	94.3	142	210	273	408	498
	17.09	42	14.3	25.6	44.8	64.6	94.5	150	210	281	394	513
20.93	34	14.1	25.5	45.3	62.7	92.0	150	210	313	412	513	
25.63	28	14.3	25.7	45.3	63.3	90.5	150	210	295	415	581	
31.39	22	14.3	25.6	45.2	60.9	89.4	150	211	308	416	560	
580	1.50	390	3.52	6.81	11.3	—	24.1	36.9	—	—	—	—
	1.84	320	3.88	7.46	15.5	23.4	28.9	39.9	—	—	—	—
	2.03	290	4.38	9.36	17.1	27.1	31.5	51.3	—	—	—	—
	2.25	260	4.71	7.80	17.2	23.4	36.2	43.4	—	—	—	—
	2.49	235	5.24	10.3	19.0	27.0	39.4	55.5	—	—	—	—
	2.76	210	4.23	8.42	17.3	24.6	38.8	46.1	—	—	—	—
	3.05	190	4.78	10.7	19.1	28.4	40.0	60.3	—	—	—	—
	3.38	175	4.38	8.45	17.8	23.9	39.7	43.2	—	—	—	—
	3.74	155	4.95	11.4	19.7	27.7	40.1	64.1	—	—	—	—
	4.13	140	4.37	8.52	18.3	24.9	36.6	42.1	—	—	—	—
	4.57	130	4.94	11.4	20.0	28.8	39.8	60.0	—	—	—	—
	5.06	115	11.8	23.0	42.1	54.8	79.0	124	183	—	—	—
	6.20	95	13.1	24.9	45.1	64.0	93.6	134	199	—	—	—
	7.59	77	14.2	25.5	45.1	64.2	93.7	146	207	—	—	—
	9.30	62	14.2	25.6	45.2	64.3	94.1	149	208	298	—	—
	11.39	50	14.3	25.5	45.3	64.4	94.3	145	209	274	401	497
	13.95	42	14.3	25.5	45.3	64.5	94.5	141	210	277	414	506
	17.09	34	14.3	25.7	45.0	64.6	94.5	150	210	285	394	520
20.93	28	14.2	25.7	45.2	62.7	92.5	150	210	314	415	519	
25.63	22	14.3	25.6	45.4	63.6	91.0	150	211	298	417	587	
31.39	18	14.3	25.7	45.4	61.1	89.7	151	211	309	416	564	

① When selecting gear drives by torque method, convert required torque (without service factor) to HP and check against the application-adjusted thermal HP ratings. For ratings at speeds higher than 3500 RPM, refer to Factory.

② Torque is in lb-in at low-speed shaft — multiply values listed by 1000.

Horsepower & Torque Ratings

Triple Reduction — Horsepower

High-Speed Shaft RPM	Nominal Ratios ±4%	Approx. L.S. Shaft RPM	Drive Size ①									
			2040	2050	2060	2070	2080	2090	2100	2110	2120	2130
1750	38.44	45	10.4	18.9	32.3	46.2	63.7	98.7	135	196	269	332
	47.08	37	8.67	15.6	26.9	37.8	53.9	86.3	119	168	239	322
	57.66	30	6.91	12.8	22.2	31.7	44.9	72.3	102	145	202	276
	70.62	25	5.69	10.4	17.1	25.3	36.9	59.8	81.6	125	169	237
	86.50	20	4.79	8.41	14.7	20.8	30.1	49.1	66.2	101	131	200
	105.9	16.5	3.80	6.85	11.4	17.7	23.8	40.4	56.0	82.5	108	150
	129.7	13.5	3.16	5.58	9.54	13.9	19.9	32.3	43.8	65.1	89.7	127
	158.9	11.0	2.50	4.54	7.96	11.9	16.3	26.6	37.0	53.8	73.2	93.6
194.6	9.0	—	—	6.62	9.65	—	21.6	—	—	—	—	
1430	38.44	37	8.53	15.5	26.7	37.7	52.1	85.7	115	170	233	283
	47.08	30	7.09	12.7	22.0	31.0	44.0	70.7	98.6	143	197	278
	57.66	25	5.65	10.5	18.1	25.9	36.7	59.3	83.4	122	165	227
	70.62	20	4.65	8.48	14.1	20.7	30.3	48.9	66.8	103	139	195
	86.50	16.5	3.92	6.88	12.0	17.0	24.6	40.1	54.2	82.8	107	163
	105.9	13.5	3.10	5.60	9.41	14.5	19.5	33.1	45.8	68.0	88.4	124
	129.7	11.0	2.59	4.56	7.83	11.4	16.3	26.4	35.8	53.4	73.4	104
	158.9	9.0	2.04	3.71	6.54	9.74	13.3	21.7	30.3	44.0	59.9	77.3
194.6	7.5	—	—	5.41	7.89	—	17.7	—	—	—	—	
1170	38.44	30	6.99	12.7	21.9	30.9	42.6	70.6	96.1	143	196	231
	47.08	25	5.80	10.4	18.0	25.5	36.0	57.9	80.8	119	162	230
	57.66	20	4.62	8.56	14.8	21.2	30.0	48.6	68.3	101	135	189
	70.62	16.5	3.81	6.94	11.6	16.9	24.9	40.0	54.7	84.5	114	160
	86.50	13.5	3.21	5.63	9.81	13.9	20.1	32.9	44.3	67.8	87.8	134
	105.9	11.0	2.54	4.58	7.73	11.8	15.9	27.1	37.5	55.7	72.4	103
	129.7	9.0	2.12	3.74	6.40	9.29	13.4	21.6	29.3	43.8	60.1	85.0
	158.9	7.5	1.67	3.04	5.36	7.97	10.9	17.8	24.8	36.1	49.0	63.8
194.6	6.0	—	—	4.42	6.47	—	14.5	—	—	—	—	
870	38.44	22	5.20	9.42	16.3	23.0	31.7	52.6	72.3	109	146	172
	47.08	18	4.32	7.76	13.4	19.0	26.8	43.1	60.2	90.0	120	172
	57.66	15	3.44	6.37	11.0	15.8	22.3	36.2	50.8	76.4	101	142
	70.62	12.5	2.83	5.17	8.71	12.6	18.5	29.8	40.7	62.9	84.6	119
	86.50	10.0	2.39	4.19	7.29	10.4	15.0	24.4	33.0	50.5	65.3	99.4
	105.9	8.3	1.89	3.41	5.78	8.81	11.8	20.1	27.9	41.4	53.8	76.7
	129.7	6.8	1.58	2.78	4.76	6.91	9.95	16.1	21.8	32.6	44.7	63.2
	158.9	5.5	1.24	2.26	3.99	5.93	8.14	13.2	18.4	26.9	36.5	47.9
194.6	4.5	—	—	3.29	4.81	—	10.8	—	—	—	—	
720	38.44	18	4.31	7.80	13.5	19.0	26.2	43.5	59.9	91.1	121	142
	47.08	15	3.58	6.43	11.1	15.8	22.2	35.7	49.8	75.2	99.7	142
	57.66	12.5	2.85	5.27	9.14	13.1	18.5	29.9	42.1	63.5	83.5	117
	70.62	10.0	2.34	4.28	7.24	10.4	15.4	24.7	33.7	52.1	70.0	98.2
	86.50	8.3	1.98	3.47	6.04	8.58	12.4	20.2	27.3	41.8	54.1	82.2
	105.9	6.8	1.56	2.82	4.80	7.29	9.79	16.7	23.1	34.3	44.6	63.5
	129.7	5.5	1.31	2.30	3.94	5.72	8.24	13.3	18.1	27.0	37.0	52.3
	158.9	4.5	1.03	1.87	3.30	4.91	6.74	11.0	15.3	22.3	30.2	39.8
194.6	3.8	—	—	2.72	3.99	—	8.91	—	—	—	—	
580	38.44	15	3.47	6.29	10.8	15.3	21.1	35.1	48.3	74.2	97.4	115
	47.08	12.5	2.88	5.18	8.93	12.7	17.9	28.8	40.2	61.1	80.4	115
	57.66	10.0	2.29	4.25	7.36	10.5	14.9	24.1	33.9	51.2	67.3	94.5
	70.62	8.3	1.89	3.45	5.85	8.39	12.4	19.9	27.2	42.0	56.4	79.1
	86.50	6.8	1.60	2.79	4.86	6.91	9.98	16.3	22.0	33.7	43.6	66.3
	105.9	5.5	1.26	2.27	3.88	5.87	7.89	13.4	18.6	27.6	35.9	51.1
	129.7	4.5	1.05	1.85	3.17	4.61	6.64	10.7	14.6	21.8	29.8	42.1
	158.9	3.8	0.83	1.51	2.66	3.96	5.43	8.83	12.3	18.0	24.3	32.2
194.6	3.0	—	—	2.19	3.21	—	7.18	—	—	—	—	

① When selecting gear drives by HP method, check required HP (without service factor) against the application-adjusted thermal HP ratings. For ratings at speeds higher than 3500 RPM, refer to Factory.

Horsepower & Torque Ratings

Triple Reduction — Torque

High-Speed Shaft RPM	Nominal Ratios ±4%	Approx. L.S. Shaft RPM	Drive Size ① ②									
			2040	2050	2060	2070	2080	2090	2100	2110	2120	2130
1750	38.44	45	14.3	25.6	44.7	62.9	89.2	140	196	271	381	473
	47.08	37	14.3	25.6	45.2	63.0	91.6	150	207	282	411	548
	57.66	30	14.3	25.6	45.2	64.6	93.0	150	210	295	415	569
	70.62	25	14.3	25.7	43.5	64.8	92.5	150	210	310	414	584
	86.50	20	14.2	25.6	45.3	64.7	95.0	151	211	313	416	588
	105.9	16.5	14.4	25.7	43.7	64.8	92.3	150	211	311	416	572
	129.7	13.5	14.2	25.6	45.1	64.9	93.4	151	211	300	416	587
	158.9	11.0	14.3	25.7	44.9	64.7	91.8	151	211	302	417	522
194.6	9.0	—	—	45.3	64.2	—	151	—	—	—	—	—
1430	38.44	37	14.3	25.7	45.2	62.8	89.2	149	204	287	404	494
	47.08	30	14.3	25.5	45.2	63.2	91.6	150	210	293	414	579
	57.66	25	14.3	25.7	45.1	64.6	93.1	150	210	304	415	573
	70.62	20	14.3	25.6	43.9	64.9	93.0	151	211	313	417	588
	86.50	16.5	14.2	25.7	45.3	64.7	95.0	150	211	314	416	587
	105.9	13.5	14.3	25.7	44.2	65.0	92.6	151	211	314	417	578
	129.7	11.0	14.3	25.7	45.3	65.1	93.6	151	211	302	417	589
	158.9	9.0	14.3	25.7	45.1	64.8	91.6	151	211	302	417	527
194.6	7.5	—	—	45.3	64.2	—	151	—	—	—	—	—
1170	38.44	30	14.3	25.7	45.4	62.9	89.2	150	208	296	415	493
	47.08	25	14.3	25.6	45.2	63.5	91.6	150	211	298	416	585
	57.66	20	14.3	25.6	45.1	64.6	93.0	151	211	308	415	583
	70.62	16.5	14.4	25.6	44.1	64.7	93.4	150	211	314	418	590
	86.50	13.5	14.2	25.7	45.3	64.7	94.9	151	211	314	417	590
	105.9	11.0	14.4	25.7	44.3	64.6	92.2	151	211	314	417	587
	129.7	9.0	14.3	25.7	45.2	64.8	94.1	151	211	302	417	588
	158.9	7.5	14.3	25.7	45.2	64.8	91.8	151	212	303	417	532
194.6	6.0	—	—	45.2	64.4	—	151	—	—	—	—	—
870	38.44	22	14.3	25.6	45.4	63.0	89.2	150	211	303	416	493
	47.08	18	14.3	25.6	45.3	63.7	91.7	151	211	303	415	589
	57.66	15	14.4	25.7	45.1	64.8	93.0	151	211	313	417	589
	70.62	12.5	14.3	25.7	44.6	64.9	93.3	151	211	314	417	590
	86.50	10.0	14.3	25.7	45.2	65.1	95.2	151	211	315	417	588
	105.9	8.3	14.4	25.7	44.6	64.9	92.1	151	211	314	417	588
	129.7	6.8	14.3	25.7	45.3	64.9	93.9	151	211	303	417	588
	158.9	5.5	14.3	25.7	45.3	64.9	92.2	151	211	303	418	537
194.6	4.5	—	—	45.3	64.4	—	151	—	—	—	—	—
720	38.44	18	14.4	25.6	45.4	62.9	89.1	150	211	306	417	492
	47.08	15	14.4	25.7	45.3	64.0	91.7	151	211	306	416	587
	57.66	12.5	14.4	25.7	45.3	64.9	93.2	151	211	314	417	587
	70.62	10.0	14.3	25.7	44.8	64.7	93.8	151	211	314	417	588
	86.50	8.3	14.3	25.7	45.3	64.9	95.1	151	211	315	417	588
	105.9	6.8	14.3	25.7	44.8	64.9	92.3	151	211	315	418	588
	129.7	5.5	14.3	25.7	45.3	64.9	94.0	151	212	303	417	588
	158.9	4.5	14.4	25.7	45.2	64.9	92.2	152	212	304	418	539
194.6	3.8	—	—	45.2	64.5	—	151	—	—	—	—	—
580	38.44	15	14.4	25.7	45.1	62.9	89.1	151	211	309	416	495
	47.08	12.5	14.3	25.7	45.3	63.8	91.8	151	211	309	417	590
	57.66	10.0	14.3	25.7	45.3	64.6	93.2	151	211	315	417	588
	70.62	8.3	14.4	25.7	44.9	64.8	93.8	151	212	314	417	588
	86.50	6.8	14.3	25.7	45.2	64.9	95.0	151	211	315	417	588
	105.9	5.5	14.4	25.7	44.9	64.8	92.3	151	211	314	417	588
	129.7	4.5	14.3	25.7	45.2	64.9	94.0	151	212	304	417	588
	158.9	3.8	14.4	25.7	45.3	65.0	92.2	151	212	304	418	542
194.6	3.0	—	—	45.2	64.4	—	151	—	—	—	—	—

① When selecting gear drives by torque method, convert required torque (without service factor) to HP and check against the application-adjusted thermal HP ratings. For ratings at speeds higher than 3500 RPM, refer to Factory.

② Torque is in lb-in at low-speed shaft — multiply values listed by 1000.

Horsepower & Torque Ratings

Quadruple Reduction — Horsepower

High-Speed Shaft RPM	Nominal Ratios ±4%	Approx. L. S. Shaft RPM	Drive Size ①								
			2050	2060	2070	2080	2090	2100	2110	2120	2130
1750	194.6	9.0	3.53	—	—	13.7	—	28.9	45.3	58.6	81.0
	238.4	7.5	3.08	5.17	7.62	11.1	17.7	24.1	37.3	48.3	67.0
	291.9	6.0	2.49	4.24	6.16	9.06	14.7	19.2	30.6	39.6	57.8
	357.5	5.0	2.08	3.46	5.03	7.32	11.9	15.8	24.8	32.1	47.4
	437.9	4.0	1.71	2.80	4.06	5.06	9.72	13.4	20.1	26.0	38.5
	536.3	3.2	1.40	2.32	3.30	3.98	7.86	11.3	15.9	21.7	31.1
	656.8	2.7	1.14	1.94	2.81	4.14	6.50	8.90	12.9	17.7	25.9
	804.5	2.2	0.920	1.58	2.29	2.86	5.36	6.90	11.1	14.8	18.3
	985.3	1.8	0.750	1.30	1.86	2.25	4.44	5.88	8.75	12.1	15.4
1430	194.6	7.5	2.89	—	—	11.2	—	23.6	37.0	47.9	68.2
	238.4	6.0	2.52	4.29	6.23	9.07	14.5	19.7	30.5	39.5	57.4
	291.9	5.0	2.04	3.47	5.03	7.40	12.0	15.7	25.0	32.4	47.2
	357.5	4.0	1.70	2.83	4.11	5.98	9.74	12.9	20.3	26.3	38.8
	437.9	3.2	1.40	2.29	3.32	4.14	7.95	11.0	16.4	21.3	31.4
	536.3	2.7	1.15	1.89	2.70	3.26	6.42	9.27	13.0	17.7	25.5
	656.8	2.2	0.930	1.58	2.30	3.38	5.32	7.27	10.6	14.4	21.2
	804.5	1.8	0.750	1.29	1.88	2.34	4.38	5.64	9.04	12.1	15.0
	985.3	1.5	0.610	1.06	1.52	1.84	3.63	4.80	7.15	9.87	12.6
1170	194.6	6.0	2.36	—	—	9.18	—	19.3	30.3	39.2	56.0
	238.4	5.0	2.06	3.51	5.09	7.42	11.8	16.1	24.9	32.3	46.9
	291.9	4.0	1.67	2.84	4.12	6.06	9.85	12.8	20.5	26.5	38.6
	357.5	3.2	1.39	2.31	3.36	4.90	7.97	10.6	16.6	21.5	31.7
	437.9	2.7	1.14	1.87	2.72	3.39	6.50	8.98	13.4	17.4	25.7
	536.3	2.2	0.940	1.55	2.21	2.67	5.26	7.58	10.6	14.5	20.8
	656.8	1.8	0.760	1.29	1.88	2.77	4.35	5.95	8.66	11.8	17.3
	804.5	1.5	0.620	1.06	1.53	1.91	3.58	4.61	7.39	9.91	12.2
	985.3	1.2	0.500	0.870	1.25	1.51	2.97	3.93	5.85	8.08	10.3
870	194.6	4.5	1.76	—	—	6.83	—	14.4	22.5	29.2	41.6
	238.4	3.8	1.53	2.61	3.79	5.52	8.81	12.0	18.6	24.0	34.9
	291.9	3.0	1.24	2.11	3.06	4.51	7.33	9.54	15.2	19.7	28.7
	357.5	2.5	1.03	1.72	2.50	3.64	5.93	7.86	12.3	16.0	23.6
	437.9	2.0	0.850	1.39	2.02	2.52	4.84	6.68	10.0	13.0	19.1
	536.3	1.6	0.700	1.15	1.64	1.98	3.91	5.64	7.91	10.8	15.5
	656.8	1.3	0.570	0.960	1.40	2.06	3.23	4.42	6.44	8.78	12.9
	804.5	1.1	0.460	0.780	1.14	1.42	2.66	3.43	5.50	7.37	9.10
	985.3	0.90	0.370	0.650	0.930	1.12	2.21	2.92	4.35	6.01	7.66
720	194.6	3.8	1.46	—	—	5.65	—	11.9	18.7	24.2	34.5
	238.4	3.0	1.27	2.16	3.13	4.57	7.29	9.91	15.4	19.9	28.9
	291.9	2.5	1.03	1.75	2.54	3.73	6.07	7.90	12.6	16.3	23.8
	357.5	2.0	0.860	1.42	2.07	3.01	4.91	6.50	10.2	13.2	19.5
	437.9	1.6	0.700	1.15	1.67	2.09	4.00	5.53	8.28	10.7	15.8
	536.3	1.3	0.580	0.950	1.36	1.64	3.23	4.67	6.55	8.92	12.8
	656.8	1.1	0.470	0.800	1.16	1.70	2.68	3.66	5.33	7.27	10.7
	804.5	0.90	0.380	0.650	0.940	1.18	2.20	2.84	4.55	6.10	7.53
	985.3	0.75	0.310	0.540	0.770	0.93	1.83	2.42	3.60	4.97	6.34
580	194.6	3.0	1.17	—	—	4.55	—	9.57	15.0	19.5	27.8
	238.4	2.5	1.02	1.74	2.52	3.68	5.87	7.98	12.4	16.0	23.3
	291.9	2.0	0.830	1.41	2.04	3.00	4.89	6.36	10.2	13.1	19.2
	357.5	1.6	0.690	1.15	1.67	2.43	3.95	5.24	8.23	10.7	15.7
	437.9	1.3	0.570	0.930	1.35	1.68	3.22	4.45	6.67	8.64	12.7
	536.3	1.1	0.470	0.770	1.09	1.32	2.61	3.76	5.28	7.19	10.3
	656.8	0.90	0.380	0.640	0.930	1.37	2.16	2.95	4.30	5.86	8.59
	804.5	0.75	0.310	0.520	0.760	0.95	1.78	2.29	3.67	4.91	6.06
	985.3	0.60	0.250	0.430	0.620	0.75	1.47	1.95	2.90	4.00	5.11

① When selecting gear drives by HP method, check required HP (without service factor) against the application-adjusted thermal HP ratings. For ratings at speeds higher than 3500 RPM, refer to Factory.

Horsepower & Torque Ratings

Quadruple Reduction — Torque

High-Speed Shaft RPM	Nominal Ratios ±4%	Approx. L.S. Shaft RPM	Drive Size ①								
			2050	2060	2070	2080	2090	2100	2110	2120	2130
1750	194.6	9.0	23.8	—	—	94.8	—	210	315	417	580
	238.4	7.5	25.7	44.6	64.9	95.0	151	211	315	418	573
	291.9	6.0	25.6	45.2	64.9	95.1	151	212	315	417	600
	357.5	5.0	25.7	45.2	64.9	95.0	151	212	315	417	600
	437.9	4.0	25.7	45.3	64.9	79.5	151	211	315	417	601
	536.3	3.2	25.6	45.4	64.5	75.0	151	211	304	418	599
	656.8	2.7	25.7	45.4	64.9	95.2	151	212	304	419	600
	804.5	2.2	25.7	45.3	64.8	79.6	151	210	316	417	516
985.3	1.8	25.7	45.2	64.4	75.1	151	212	305	419	522	
1430	194.6	7.5	23.9	—	—	94.9	—	210	314	417	598
	238.4	6.0	25.7	45.3	64.9	95.0	151	211	315	418	600
	291.9	5.0	25.7	45.3	64.8	95.0	150	212	315	418	600
	357.5	4.0	25.7	45.3	64.9	95.0	151	211	315	418	601
	437.9	3.2	25.7	45.3	64.9	79.6	151	212	314	418	600
	536.3	2.7	25.8	45.2	64.6	75.2	151	212	305	418	601
	656.8	2.2	25.7	45.2	65.0	95.1	151	212	305	417	601
	804.5	1.8	25.7	45.2	65.1	79.7	151	210	315	418	517
985.3	1.5	25.7	45.1	64.4	75.2	151	211	305	418	522	
1170	194.6	6.0	23.8	—	—	95.0	—	210	315	417	600
	238.4	5.0	25.7	45.3	64.8	95.0	150	211	314	418	599
	291.9	4.0	25.7	45.3	64.9	95.1	151	211	315	418	599
	357.5	3.2	25.7	45.2	64.9	95.2	151	212	315	418	600
	437.9	2.7	25.6	45.3	65.0	79.7	151	212	314	418	600
	536.3	2.2	25.7	45.3	64.6	75.3	151	211	303	418	599
	656.8	1.8	25.7	45.1	64.9	95.3	151	212	305	418	599
	804.5	1.5	25.7	45.4	64.7	79.5	151	210	315	418	514
985.3	1.2	25.7	45.3	64.7	75.4	151	212	305	418	522	
870	194.6	4.5	23.9	—	—	95.1	—	211	314	418	599
	238.4	3.8	25.6	45.3	64.9	95.1	151	212	316	417	600
	291.9	3.0	25.7	45.3	64.8	95.2	151	211	314	417	599
	357.5	2.5	25.6	45.2	64.9	95.1	151	212	314	418	601
	437.9	2.0	25.7	45.2	64.9	79.6	151	212	315	420	600
	536.3	1.6	25.7	45.2	64.5	75.1	151	212	305	419	601
	656.8	1.3	25.7	45.2	65.0	95.3	151	211	305	418	601
	804.5	1.1	25.7	45.2	64.9	79.5	151	210	315	418	516
985.3	0.90	25.7	45.2	64.6	75.2	151	211	305	418	522	
720	194.6	3.8	24.0	—	—	95.1	—	211	316	419	601
	238.4	3.0	25.7	45.3	64.8	95.1	151	211	316	418	600
	291.9	2.5	25.8	45.4	65.0	95.1	151	212	315	417	600
	357.5	2.0	25.7	45.1	65.0	95.0	151	211	314	417	600
	437.9	1.6	25.7	45.2	64.8	79.8	151	212	315	417	599
	536.3	1.3	25.7	45.3	64.6	75.1	151	212	305	418	599
	656.8	1.1	25.7	45.2	65.1	95.0	151	212	305	418	602
	804.5	0.90	25.7	45.3	64.9	79.8	151	210	315	418	516
985.3	0.75	25.7	45.3	64.6	75.3	151	212	305	418	522	
580	194.6	3.0	23.8	—	—	95.0	—	210	314	419	601
	238.4	2.5	25.6	45.3	64.8	95.1	151	211	316	417	601
	291.9	2.0	25.7	45.4	64.8	95.0	151	211	316	416	601
	357.5	1.6	25.7	45.4	65.1	95.2	151	212	315	420	599
	437.9	1.3	25.7	45.2	65.1	79.6	151	212	315	418	598
	536.3	1.1	25.7	45.2	64.3	75.1	151	212	305	418	599
	656.8	0.90	25.7	45.3	64.9	95.1	151	212	305	418	600
	804.5	0.75	25.7	45.3	65.0	79.7	151	210	315	418	515
985.3	0.60	25.7	45.3	64.6	75.2	151	212	305	418	522	

① When selecting gear drives by torque method, convert required torque (without service factor) to HP and check against the application-adjusted thermal HP ratings. For ratings at speeds higher than 3500 RPM, refer to Factory.

② Torque is in lb-in at low-speed shaft — multiply values listed by 1000.

Thermal Horsepower

Thermal horsepower is the actual horsepower (without service factor) that a drive will transmit continually for three hours or more without overheating.

Thermal ratings need not be considered when the continuous operating period does not exceed three hours and the shutdown time equals or exceeds the running time. However, when the running time exceeds the shutdown time, selection must be made on a basis of adequate thermal rating.

The duty cycle factor considers an increase in the Basic Thermal Rating for gear drives that operate less than 100% of any one hour time period. If a drive operates for more than three hours and operates continuously for any given hour of the day, then the duty cycle must be considered 100%.

Checking the thermal horsepower is extremely important, for if the drive creates heat faster than it can be dissipated, severe damage may occur.

The application-adjusted thermal capacity must be greater than the actual brake horsepower. Determine the Application-Adjusted Thermal Capacity by multiplying the Basic Thermal Capacity, pages 43-45, by the appropriate environmental factors (Table 8 through Table 12). Compare the actual power rating required (without service factor) with the application-adjusted thermal rating. If the actual load exceeds the application-adjusted thermal rating, shaft fans, electric fan or cooling tubes may be added, an optional oil-to-water or oil-to-air heat exchanger may be used, or a larger drive may be selected.

NOTE: Sizes 2040 and 2050 are not available with shaft fan, electric fan or cooling tubes.

Application-Adjusted Thermal Rating

$P_{TA} = B_1 \times B_2 \times B_3 \times B_4 \times B_5 \times P_T$ where:

P_{TA} = Application-Adjusted Thermal Rating

P_T = Basic Thermal Rating (pages 43-45)

B_1 = Ambient Air Temperature Factor, Table 8

B_2 = Altitude Factor, Table 9

B_3 = Ambient Air Velocity Factor, Table 10

B_4 = Inlet Water Temperature Factor, Table 11

B_5 = Duty Cycle Factor, Table 12

Thermal Rating Example

A ball mill with helical ring gear, has a 500 hp, 1750 rpm motor coupling connected to an UltraMax Size 2110FC2 drive with a ratio of 9.30:1. From the Service Factor table on page 8, the minimum service factor is 1.50. From page 31 the mechanical horsepower rating is 750 hp. The actual service factor is

$$750 \div 500 = 1.50.$$

Check to see if the actual horsepower rating is greater than the application-adjusted thermal rating under the following conditions:

Ambient Temperature = 120°F

Altitude = Sea Level

Installed Environment = Indoors (large room, air velocity undefined)

Inlet Water Temperature = 100°F

Continuous Duty

First find P_{TA} with no auxiliary cooling ($P_{TA} = B_1 \times B_2 \times B_3 \times B_5 \times P_T$).

$$B_1 = 0.69 \text{ (Table 8)}$$

$$B_2 = 1.00 \text{ (Table 9)}$$

$$B_3 = 1.00 \text{ (Table 10)}$$

$$B_5 = 1.00 \text{ (Table 12)}$$

$$P_T = 179 \text{ (page 44)}$$

$$P_{TA} = 0.69 \times 1.00 \times 1.00 \times 1.00 \times 179 = 124 \text{ thermal hp.}$$

This drive will require cooling because 124 thermal hp is less than the motor horsepower of 500. First try a shaft fan as shown below.

P_{TA} with Shaft Fan = $B_1 \times B_2 \times B_5 \times P_T$

$$B_1 = 0.69 \text{ (Table 8)}$$

$$B_2 = 1.00 \text{ (Table 9)}$$

$$B_5 = 1.00 \text{ (Table 12)}$$

$$P_T = 672 \text{ (page 44)}$$

$P_{TA} = 0.69 \times 1.00 \times 1.00 \times 672 = 464$ thermal hp which is still less than 500. Next try an electric fan.

P_{TA} with an Electric Fan = $B_1 \times B_2 \times B_5 \times P_T$

$$B_1 = 0.69 \text{ (Table 8)}$$

$$B_2 = 1.00 \text{ (Table 9)}$$

$$B_5 = 1.00 \text{ (Table 12)}$$

$$P_T = 795 \text{ (page 44)}$$

$$P_{TA} = 0.69 \times 1.00 \times 1.00 \times 795 = 549 \text{ thermal hp which is acceptable.}$$

Cooling Tubes are also acceptable.

P_{TA} with Cooling Tubes = $B_1 \times B_4 \times B_5 \times P_T$

$$B_1 = 0.91 \text{ (Table 8)}$$

$$B_4 = 0.83 \text{ (Table 11)}$$

$$B_5 = 1.00 \text{ (Table 12)}$$

$$P_T = 1520 \text{ (page 44)}$$

$$P_{TA} = 0.91 \times 0.83 \times 1.00 \times 1520 = 1150 \text{ thermal hp.}$$

Thermal Horsepower

Table 8 — Ambient Temperature Factor – B₁ (For all cooling methods)

Ambient Temperature ①	Factor with or without Shaft or Electric Fan	Factor with Cooling Tubes
50°F	1.19	1.06
60°F	1.13	1.04
70°F	1.07	1.02
80°F	1.00	1.00
90°F	0.93	0.98
100°F	0.85	0.96
110°F	0.78	0.94
120°F	0.69	0.91

① Basic thermal ratings are for an ambient temperature of 80°F (27°C), from sea level to 2500 ft. Application-adjusted thermal ratings must be calculated using the application correction factors listed in these tables before comparing to the required load. For cooling beyond the range of cooling tubes, refer to Factory for the selection of oil-to-water or oil-to-air heat exchangers. Thermal ratings with cooling tubes are based on a maximum water inlet temperature of 70°F (21°C) with a 2 gpm flow rate.

Table 9 — Altitude Factor – B₂ (For air cooling only)

Altitude – ft. Sea Level = 0	Factor with or without Auxiliary Cooling
0 to 2,500	1.00
2,500	0.95
5,000	0.90
7,500	0.85
10,000	0.81
12,500	0.76
15,000	0.72

Table 10 — Ambient Air Velocity Factor – B₃ (For no auxiliary cooling only)

Sustained Ambient Air Velocity (fpm) ②	Installed Environment	Factor without Shaft or Electric Fan or Cooling Tubes
Less than 100 fpm (1 mph)	Small Confined Space	0.75
Between 100 fpm & 275 fpm (1 to 3 mph)	Large Indoor Room	1.00
Between 275 fpm & 725 fpm (3 to 8 mph)	Large Indoor Room	1.40
Greater than 725 fpm (8 mph)	Outdoors	1.90

② The sustained ambient air velocity must be a continuous flow of air directly onto the gear drive. If the air flow cannot be counted on to be continuous, an ambient air velocity factor of 1.00 must be used.

Table 11 — Inlet Water Temperature Factor – B₄ (For water cooling only)

Inlet Water Temperature	Factor with Cooling Tubes Only
50°F	1.11
60°F	1.05
70°F	1.00
80°F	0.94
90°F	0.88
100°F	0.83

Table 12 — Duty Cycle Factor ③ – B₅ (For all cooling methods)

% Operating Time per Hour	Factor with or without Auxiliary Cooling
100%	1.00
80%	1.05
60%	1.15
40%	1.35
20%	1.80

③ The duty cycle factor must be based on the percentage of each hour that the drive is operating. For example: a gear drive operating for 48 minutes and resting for 12 minutes every hour of the day has an 80% duty cycle, but a drive operating for four hours and resting for four hours has a 100% duty cycle. Where % run time per hour falls between values shown above, use next higher % run time.

Basic Thermal Ratings

Double Reduction ①

Nominal Ratios	High-Speed Shaft RPM	Auxiliary Cooling	Drive Size						
			2040	2050	2060	2070	2080	2090	
1.50 thru 2.49	3500	None	②	②	②	②	②	②	
		Shaft Fan	②	②	②	②	②	②	
		Electric Fan	②	②	②	②	②	②	
		Cooling Tubes	②	②	②	②	②	②	
	2900	None	②	②	②	②	②	②	
		Shaft Fan	②	②	②	②	②	②	
		Electric Fan	②	②	②	②	②	②	
		Cooling Tubes	②	②	②	②	②	②	
	2400	None	②	②	②	②	②	②	
		Shaft Fan	②	②	②	②	②	②	
		Electric Fan	②	②	②	②	②	②	
		Cooling Tubes	②	②	②	②	②	②	
	1750	None	60.5	65.5	79.3	92.1	118	176	
		Shaft Fan	—	—	153	178	237	560	
		Electric Fan	—	—	245	288	361	664	
		Cooling Tubes	—	—	580	651	740	1190	
	1430	None	64.3	72.5	84.8	100	127	196	
		Shaft Fan	—	—	146	170	224	523	
		Electric Fan	—	—	243	286	358	676	
		Cooling Tubes	—	—	539	610	696	1140	
	1170	None	67.0	77.8	88.4	104	131	212	
		Shaft Fan	—	—	138	161	211	485	
		Electric Fan	—	—	239	281	351	677	
		Cooling Tubes	—	—	497	566	648	1080	
	870	None	67.9	83.5	88.2	104	130	220	
		Shaft Fan	—	—	125	146	189	426	
		Electric Fan	—	—	229	269	334	655	
		Cooling Tubes	—	—	445	497	571	970	
	720	None	67.2	84.7	60.5	101	127	224	
		Shaft Fan	—	—	89.9	136	176	394	
		Electric Fan	—	—	195	260	322	641	
		Cooling Tubes	—	—	458	501	549	901	
	580	None	65.6	84.4	65.8	75.8	89.0	226	
		Shaft Fan	—	—	91.0	105	129	363	
		Electric Fan	—	—	195	228	277	621	
		Cooling Tubes	—	—	423	475	533	823	
	2.76 thru 4.57	3500	None	②	②	②	②	②	②
			Shaft Fan	②	②	②	②	②	②
			Electric Fan	②	②	②	②	②	②
			Cooling Tubes	②	②	②	②	②	②
2900		None	②	②	②	②	②	②	
		Shaft Fan	②	②	②	②	②	②	
		Electric Fan	②	②	②	②	②	②	
		Cooling Tubes	②	②	②	②	②	②	
2400		None	②	②	②	②	②	②	
		Shaft Fan	②	②	②	②	②	②	
		Electric Fan	②	②	②	②	②	②	
		Cooling Tubes	②	②	②	②	②	②	
1750		None	58.2	66.4	80.3	92.5	117	178	
		Shaft Fan	—	—	147	171	228	512	
		Electric Fan	—	—	229	273	343	598	
		Cooling Tubes	—	—	461	537	623	920	
1430		None	59.0	71.6	83.4	97.5	123	194	
		Shaft Fan	—	—	138	162	214	467	
		Electric Fan	—	—	225	269	338	593	
		Cooling Tubes	—	—	420	494	574	860	
1170		None	58.8	74.1	84.5	99.8	126	201	
		Shaft Fan	—	—	129	152	200	426	
		Electric Fan	—	—	219	263	330	582	
		Cooling Tubes	—	—	418	450	526	796	
870		None	57.1	74.6	57.6	65.5	76.2	151	
		Shaft Fan	—	—	91.4	104	126	368	
		Electric Fan	—	—	185	217	260	555	
		Cooling Tubes	—	—	416	470	532	698	
720		None	55.5	73.6	63.0	72.1	83.8	167	
		Shaft Fan	—	—	91.0	104	126	338	
		Electric Fan	—	—	185	218	264	538	
		Cooling Tubes	—	—	385	438	501	703	
580		None	53.5	71.7	66.5	76.6	89.8	178	
		Shaft Fan	—	—	88.9	103	127	236	
		Electric Fan	—	—	181	215	263	450	
		Cooling Tubes	—	—	348	400	461	686	

① Basic thermal ratings listed are for an ambient temperature of 80°F (27°C), from sea level to 2500 ft. Application adjusted thermal ratings must be calculated using the application correction factors on page 42 before comparing to the required load. For cooling beyond the range of cooling tubes, refer to Factory for the selection of oil-to-water or oil-to-air heat exchangers. Thermal ratings with cooling tubes are based on a maximum water inlet temperature of 70°F (21°C) with a 2 gpm flow rate.

② External cooling required for these selections; refer to Factory.

Basic Thermal Ratings

Double Reduction (Continued) ①

Nominal Ratios	High-Speed Shaft RPM	Auxiliary Cooling	Drive Size										
			2040	2050	2060	2070	2080	2090	2100	2110	2120	2130	
5.06 thru 11.39	3500	None	21.7	—	②	②	②	②	②	②	②	②	②
		Shaft Fan	—	—	②	②	②	②	②	②	②	②	②
		Electric Fan	—	—	②	②	②	②	②	②	②	②	②
		Cooling Tubes	—	—	②	②	②	②	②	②	②	②	②
	2900	None	34.1	19.7	②	②	②	②	②	②	②	②	②
		Shaft Fan	—	—	②	②	②	②	②	②	②	②	②
		Electric Fan	—	—	②	②	②	②	②	②	②	②	②
		Cooling Tubes	—	—	②	②	②	②	②	②	②	②	②
	2400	None	36.4	34.6	②	②	②	②	②	②	②	②	②
		Shaft Fan	—	—	②	②	②	②	②	②	②	②	②
		Electric Fan	—	—	②	②	②	②	②	②	②	②	②
		Cooling Tubes	—	—	②	②	②	②	②	②	②	②	②
	1750	None	40.4	50.0	57.7	72.0	87.9	122	151	179	211	205	
		Shaft Fan	—	—	108	133	170	362	507	672	914	967	
		Electric Fan	—	—	170	212	255	424	600	795	1090	1240	
		Cooling Tubes	—	—	321	384	426	1010	1290	1520	2410	2290	
	1430	None	42.0	51.8	61.1	75.9	92.3	132	166	198	242	253	
		Shaft Fan	—	—	102	126	159	332	467	620	854	912	
		Electric Fan	—	—	167	210	251	423	603	806	1130	1310	
		Cooling Tubes	—	—	291	351	390	928	1190	1420	2280	2860	
	1170	None	42.5	54.6	62.4	77.4	93.8	141	179	216	268	281	
		Shaft Fan	—	—	95.7	119	149	303	428	569	790	859	
		Electric Fan	—	—	162	205	245	415	596	801	1130	1330	
		Cooling Tubes	—	—	268	318	355	845	1100	1320	2130	2690	
870	None	41.7	55.9	61.9	77.6	93.3	145	190	235	300	317		
	Shaft Fan	—	—	86.4	108	134	265	374	498	697	771		
	Electric Fan	—	—	154	195	233	398	575	777	1110	1320		
	Cooling Tubes	—	—	282	316	347	726	953	1160	1890	2420		
720	None	40.6	55.4	44.3	53.4	91.6	144	192	240	314	338		
	Shaft Fan	—	—	64.2	77.2	125	243	343	456	641	715		
	Electric Fan	—	—	133	164	224	384	557	754	1090	1290		
	Cooling Tubes	—	—	288	339	354	654	864	1060	1740	2240		
580	None	39.1	54.1	46.9	57.0	65.6	141	189	240	320	352		
	Shaft Fan	—	—	63.5	76.9	92.5	220	311	413	582	653		
	Electric Fan	—	—	131	163	191	367	534	725	1050	1250		
	Cooling Tubes	—	—	261	310	340	731	790	948	1560	2020		
13.95 thru 31.39	3500	None	31.6	35.5	—	—	—	—	—	—	—	—	
		Shaft Fan	—	—	—	—	—	—	—	—	—	—	
		Electric Fan	—	—	131	167	204	325	—	—	—	—	
		Cooling Tubes	—	—	230	286	325	746	—	—	—	—	
	2900	None	33.2	39.0	—	—	—	—	—	—	—	—	
		Shaft Fan	—	—	—	—	—	—	—	—	—	—	
		Electric Fan	—	—	131	170	207	332	—	—	—	—	
		Cooling Tubes	—	—	211	265	302	691	—	—	—	—	
	2400	None	33.8	42.2	—	—	—	—	—	—	—	—	
		Shaft Fan	—	—	—	—	—	—	—	—	—	—	
		Electric Fan	—	—	130	170	206	333	—	—	—	—	
		Cooling Tubes	—	—	192	243	278	633	—	—	—	—	
	1750	None	33.4	44.3	50.0	61.8	75.6	61.5	65.3	175	213	221	
		Shaft Fan	—	—	82.8	107	136	281	403	543	763	862	
		Electric Fan	—	—	125	164	199	324	467	628	884	1060	
		Cooling Tubes	—	—	225	267	265	538	707	855	1410	1820	
	1430	None	32.6	44.3	33.3	38.3	75.9	71.7	82.4	90.5	75.8	253	
		Shaft Fan	—	—	61.0	73.4	125	252	361	485	683	777	
		Electric Fan	—	—	107	136	192	315	456	613	870	1050	
		Cooling Tubes	—	—	231	284	281	481	636	776	1280	1670	
	1170	None	31.6	43.5	35.8	42.5	48.3	81.6	94.9	107	112	85.3	
		Shaft Fan	—	—	59.4	73.3	90.3	226	323	434	612	699	
		Electric Fan	—	—	106	137	162	304	441	595	848	1020	
		Cooling Tubes	—	—	212	263	293	521	673	699	1160	1520	
870	None	29.8	41.7	37.6	46.6	54.0	96.0	114	130	144	146		
	Shaft Fan	—	—	55.0	69.2	84.7	150	193	246	521	596		
	Electric Fan	—	—	103	134	159	246	339	446	808	977		
	Cooling Tubes	—	—	170	215	242	539	685	799	1130	1280		
720	None	28.6	40.3	38.3	48.6	57.0	102	124	148	167	166		
	Shaft Fan	—	—	52.5	67.0	82.0	144	190	243	295	542		
	Electric Fan	—	—	99.6	131	156	246	346	459	607	943		
	Cooling Tubes	—	—	154	195	221	493	636	751	1200	1370		
580	None	27.2	38.5	38.2	49.2	58.3	105	134	162	187	191		
	Shaft Fan	—	—	49.5	63.9	78.1	137	184	236	292	299		
	Electric Fan	—	—	95.7	126	151	241	344	459	626	718		
	Cooling Tubes	—	—	136	174	198	442	577	689	1120	1400		

① Basic thermal ratings listed are for an ambient temperature of 80°F (27°C), from sea level to 2500 ft. Application adjusted thermal ratings must be calculated using the application correction factors on page 42 before comparing to the required load. For cooling beyond the range of cooling tubes, refer to Factory for the selection of oil-to-water or oil-to-air heat exchangers. Thermal ratings with cooling tubes are based on a maximum water inlet temperature of 70°F (21°C) with a 2 gpm flow rate.

② External cooling required for these selections; refer to Factory.

Basic Thermal Ratings

Triple & Quadruple Reduction ^①

Nominal Ratios	High-Speed Shaft RPM	Auxiliary Cooling	Drive Size										
			2040	2050	2060	2070	2080	2090	2100	2110	2120	2130	
Triple Reduction													
38.44 thru 86.50	1750	None	20.1	29.2	31.8	41.5	55.0	80.0	120	135	161	176	
		Shaft Fan	—	—	—	—	—	—	—	206	252	358	409
		Electric Fan	—	—	79.1	105	130	187	298	400	551	680	1460
	Cooling Tubes	—	—	163	208	237	452	650	760	1160	1460		
	1430	None	19.1	27.9	31.1	41.1	50.7	75.0	110	130	163	184	
		Shaft Fan	—	—	—	—	—	—	—	187	229	324	372
		Electric Fan	—	—	75.7	101	125	180	288	385	532	658	
	Cooling Tubes	—	—	147	189	217	412	598	702	1080	1360		
	1170	None	18.1	26.5	30.1	40.1	49.6	70.0	100	125	161	187	
		Shaft Fan	—	—	—	—	—	—	—	169	208	293	338
		Electric Fan	—	—	72.2	97.5	120	172	276	369	511	632	
	Cooling Tubes	—	—	132	171	197	374	547	644	993	1260		
	870	None	16.7	24.6	28.5	38.2	47.3	63.4	94.6	120	157	183	
		Shaft Fan	—	—	—	—	—	—	—	147	181	254	294
		Electric Fan	—	—	67.1	90.8	112	160	258	344	477	590	
	Cooling Tubes	—	—	112	146	169	321	474	562	872	1110		
	720	None	15.9	23.4	27.3	36.7	45.6	61.0	91.6	116	152	179	
		Shaft Fan	—	—	—	—	—	—	—	134	166	232	269
		Electric Fan	—	—	63.8	86.6	107	152	246	328	455	563	
	Cooling Tubes	—	—	100	131	152	289	430	512	797	1020		
	580	None	14.9	22.1	25.9	35.0	43.4	58.1	87.6	111	146	172	
		Shaft Fan	—	—	—	—	—	—	—	122	151	209	244
		Electric Fan	—	—	60.2	81.8	101	144	233	310	431	532	
	Cooling Tubes	—	—	88.1	116	134	255	382	457	715	918		
105.9 thru 194.6	1750	None	13.0	18.4	23.5	31.4	35.8	50.0	74.7	100	130	157	
		Shaft Fan	—	—	—	—	—	—	—	146	189	266	321
		Electric Fan	—	—	56.1	75.8	86.3	130	207	290	396	514	
	Cooling Tubes	—	—	90.2	118	123	272	384	460	705	969		
	1430	None	12.3	17.5	22.6	30.3	34.6	48.6	72.6	97.1	126	153	
		Shaft Fan	—	—	—	—	—	—	—	131	169	236	286
		Electric Fan	—	—	53.3	72.1	82.2	123	198	276	377	490	
	Cooling Tubes	—	—	79.9	105	110	244	346	415	639	884		
	1170	None	11.7	16.6	21.6	29.0	33.2	46.7	70.0	93.3	121	149	
		Shaft Fan	—	—	—	—	—	—	—	117	151	211	256
		Electric Fan	—	—	50.5	68.5	78.0	117	188	262	358	465	
	Cooling Tubes	—	—	70.6	93.9	98.6	218	310	373	576	803		
	870	None	10.7	15.3	20.1	27.1	31.0	43.8	65.7	87.3	113	140	
		Shaft Fan	—	—	—	—	—	—	—	100	130	179	219
		Electric Fan	—	—	46.5	63.2	72.0	108	174	242	330	430	
	Cooling Tubes	—	—	58.4	78.4	82.5	183	262	315	490	689		
	720	None	10.2	14.6	19.1	25.9	29.6	41.8	62.8	83.3	108	134	
		Shaft Fan	—	—	—	—	—	—	—	91.1	118	162	199
		Electric Fan	—	—	44.1	60.0	68.3	103	165	229	313	408	
	Cooling Tubes	—	—	51.7	69.6	73.5	163	234	282	439	622		
	580	None	9.5	13.7	18.0	24.4	27.9	39.5	59.5	78.7	102	127	
		Shaft Fan	—	—	—	—	—	—	—	82.0	106	145	179
		Electric Fan	—	—	41.4	56.5	64.3	97.0	155	216	294	384	
	Cooling Tubes	—	—	44.9	60.7	68.0	142	204	247	385	549		
Quadruple Reduction													
238.4 thru 985.3	580 thru 1750	None	—	16.1	18.6	23.5	29.6	38.8	48.5	58.9	72.6	85.7	

① Basic thermal ratings listed are for an ambient temperature of 80°F (27°C), from sea level to 2500 ft. Application adjusted thermal ratings must be calculated using the application correction factors on page 42 before comparing to the required load. For cooling beyond the range of cooling tubes, refer to Factory for the selection of oil-to-water or oil-to-air heat exchangers. Thermal ratings with cooling tubes are based on a maximum water inlet temperature of 70°F (21°C) with a 2 gpm flow rate.

Cooling for UltraMax Drives

As noted on page 5, the application-adjusted thermal capacity is the actual horsepower (without service factor) that a drive will transmit continually for three hours or more without overheating. If a drive creates heat faster than it can be dissipated, severe damage may occur.

Shaft-Driven Cooling Fans

Cooling fans provide a simple and inexpensive way to utilize the mechanical rating of UltraMax gear drives by lowering operating temperatures, thus increasing thermal horsepower capacity. Cooling fans have been successfully used on electric motors and other related machinery for many years. They eliminate the need for water or oil cooling, pumps and external piping. The sound level at 1750 rpm is about the same as that from fans on totally enclosed, fan-cooled driving motors. Less than one quarter of one percent cataloged horsepower rating is required to drive the fans. For dimensions, refer to page 59.

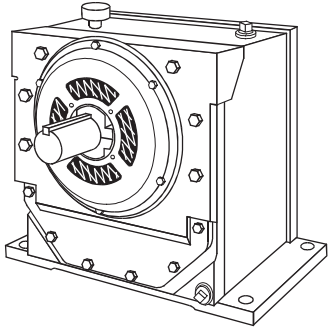

Shaft-Driven Cooling Fan

Electric Cooling Fans

Electric fans achieve thermal capacities up to twice that of shaft driven fans and can be thermostatically controlled to shut off when not required. Electric fans can be mounted on either side of the drive, permitting full use of usable shaft extension. For dimensions, refer to page 70.

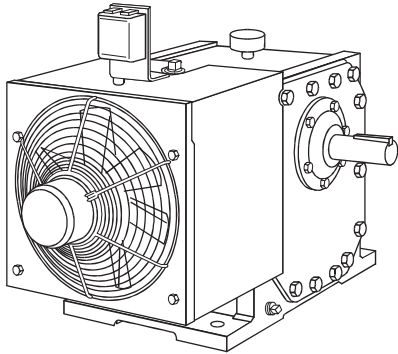

Electric Cooling Fan

Cooling Tubes

Cooling tubes are an economical alternative for thermal requirements beyond the range of fans. A series of straight, finned tubes are provided directly in the sump of the drive. Water is circulated through these tubes to cool the oil. Since there are no joints or connections inside the drive, leakage of water into the drive is eliminated. For dimensions, refer to page 71.

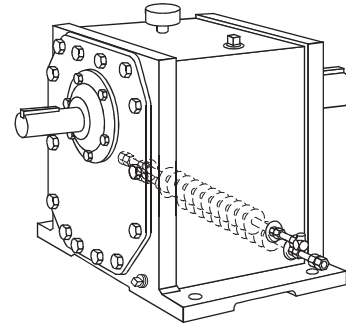

Cooling Tubes

External Pumps & Coolers

Type PC external pump and cooler assemblies provide cooling capacity beyond the range of fans and cooling tubes, and will allow the drive to run at full mechanical rating. Packages are available for all UltraMax sizes. For selection, price and delivery, provide full application details to your local Regal Rexnord™ district office.

Overhung Loads

High- & Low-Speed Shaft

The overhung load and thrust ratings published in this catalog are based on a combination of the most unfavorable conditions or rotation, speed, direction of applied load and drive loading. If the calculated load exceeds the published value, or if an overhung load and thrust load are applied simultaneously to a shaft, consult Factory and provide complete application information (hp, rpm, driven machine, hours of operation per day, direction of rotation, direction and location of applied loads).

Overhung Loads — Overhung load is imposed upon a shaft when a pinion, sprocket or sheave is used as a power take-off. The magnitude of the load varies with the type of take-off and its proximity to the shaft bearing. Calculate the load (including minimum required service factor) and check the result against the tabulated overhung load rating.

Overhung Load Formula:

The overhung load formula below considers the transmitted horsepower without service factor. This is appropriate for applications where starting loads, momentary overloads and brake capacities do not exceed 200% of drive rating (100% overload). For other conditions, compute an equivalent power by multiplying the transmitted horsepower by the appropriate service factor.

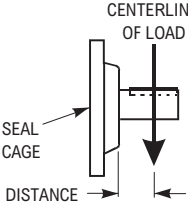
$$\text{Overhung Load} = \frac{126,000 \times \text{HP} \times F_c \times L_f}{\text{Pitch Dia} \times \text{RPM}}$$

F_c = Load Connection Factor

Sprocket ①	1.00
Machined Pinion & Gear ①	1.25
Synchronous (Timing) Belts.....	1.30
V-Belt.....	1.50
Flat Belt.....	2.50

L_f = Load Location Factor ②

L.S.S. — See table on page 48.

H.S.S. — See instructions at right.

- ① Refer all multiple chain sprocket and pinion-mounted applications to the Factory for deflection analysis.
- ② For load location factors for drives with fan or external backstop, refer to Catalog 311-112.

Locate the center of the load as close to the drive seal cage as practical to minimize the overhung load and increase bearing life.

Consult Factory for higher overhung load ratings — In many cases, overhung load capacity in excess of that published is available. Published ratings are based on a combination of the most unfavorable conditions of rotation, speed, direction of applied load and drive loading. If the actual load should exceed the published capacity, refer full details to the Factory; provide complete application information (see page 13), as well as direction of rotation, location and direction of applied load.

Low-Speed Shaft

Calculate low-speed shaft overhung load using the formula and F_c values at left. The L_f load location factors tabulated on page 48 are based on the distance from the centerline of the load to the drive seal cage.

Low-Speed Shaft Overhung Load Example — An UltraMax size 2070FC2 drive is used to drive a uniformly-loaded chain conveyor. The drive is driven by a 50 hp, 1750 rpm, electric motor coupling connected to the high-speed shaft. The low-speed shaft is rotating at 85.2 rpm and is chain-connected to the conveyor shaft. The drive-mounted sprocket has a pitch diameter of 12.85 inches, and the centerline of the teeth is located 3.00 inches out from the low-speed seal cage.

$$\text{Overhung Load} = \frac{126,000 \times (50 \times 1.00) \times .98}{12.85 \times 85.2} = 5639 \text{ lb}$$

Since the allowable overhung load of the 2070 is 8,500 lb, this application is acceptable.

Thrust Loads — Refer to page 54 for low-speed shaft thrust capacities. Thrust capacities are for pure thrust loads. If thrust and overhung loads are applied simultaneously, or if loads exceed these capacities, consult Factory.

High-Speed Shaft

High-speed shaft overhung load ratings published on pages 50-53 are for normal conditions where the centerline of the load is one shaft diameter from the seal cage (or external backstop), and for speeds of 1170 rpm or lower. Where the centerline of the load is one shaft diameter or closer, calculate the high-speed shaft overhung load using $L_f = 1$ in the formula at left. Check the result against the rating on pages 50-53. Higher overhung load capacities are available when the full drive torque rating is not utilized. Refer to the Factory for higher ratings for these conditions or if the calculated load (using $L_f = 1$) exceeds the published value or if the load is applied at a distance greater than one shaft diameter from the high-speed shaft seal cage or external backstop. High-speed shaft load location factors are available in Catalog 311-312.

High-Speed Shaft Overhung Load Example — A 15 hp, 1750 rpm motor with a 4-inch pitch diameter sheave is V-belt-connected to an UltraMax size 2060FC2 drive which has a nominal ratio of 31.39:1. A 12-inch pitch diameter sheave is mounted on the drive high-speed shaft 1.50 inches (less than one shaft diameter) from the seal cage. Calculate the high-speed shaft rpm and overhung load as follows:

$$\text{Drive high-speed RPM} = \frac{4}{12} \times 1750 = 583 \text{ RPM}$$

Using the overhung load formula,

$$\text{Overhung Load} = \frac{126,000 \times 15 \times 1.50 \times 1.00}{12 \times 583} = 405 \text{ lb}$$

From the table on page 50, in the 580 high-speed shaft rpm section, the overhung load capacity for a 2060FC2 drive with a 31.39:1 ratio is 600 lb. The actual load is less than the published capacity and is therefore acceptable.

Overhung Loads

LSS Lf Load Location Factors — Double, Triple & Quadruple Reduction ①

Distance (in)	Drive Size									
	2040	2050	2060	2070	2080	2090	2100	2110	2120	2130
1	0.85	0.82	0.82	0.79	0.80	0.78	0.77	0.75	0.76	0.74
1-1/2	0.92	0.88	0.87	0.84	0.84	0.82	0.80	0.79	0.78	0.76
1-3/4	0.96	0.91	0.90	0.86	0.86	0.83	0.82	0.80	0.80	0.77
2	1.00	0.94	0.92	0.89	0.88	0.85	0.83	0.82	0.81	0.79
2-1/2	1.13	1.00	0.97	0.93	0.92	0.89	0.87	0.85	0.84	0.81
2-3/4	1.20	1.06	1.00	0.95	0.94	0.91	0.88	0.86	0.85	0.83
3	1.26	1.11	1.05	0.98	0.96	0.93	0.90	0.88	0.86	0.84
3-1/4	1.33	1.17	1.10	1.00	0.98	0.94	0.92	0.89	0.88	0.85
3-1/2	1.39	1.23	1.15	1.04	1.00	0.96	0.93	0.91	0.89	0.87
4	1.53	1.34	1.24	1.13	1.08	1.00	0.97	0.94	0.92	0.89
4-1/2	–	1.45	1.34	1.22	1.16	1.07	1.00	0.97	0.95	0.92
4-3/4	–	1.51	1.39	1.26	1.20	1.10	1.03	0.98	0.96	0.93
5	–	1.57	1.44	1.30	1.24	1.14	1.06	1.00	0.97	0.95
5-1/4	–	–	1.48	1.34	1.28	1.17	1.10	1.03	0.99	0.96
5-1/2	–	–	1.53	1.39	1.32	1.21	1.13	1.06	1.00	0.97
5-3/4	–	–	–	1.43	1.36	1.24	1.16	1.09	1.03	0.99
6	–	–	–	1.47	1.40	1.28	1.19	1.12	1.06	1.00
6-1/2	–	–	–	1.56	1.48	1.35	1.25	1.18	1.11	1.05
7	–	–	–	–	1.56	1.42	1.32	1.24	1.17	1.11
7-1/2	–	–	–	–	–	1.49	1.38	1.30	1.22	1.16
8	–	–	–	–	–	1.56	1.45	1.36	1.28	1.21
8-1/2	–	–	–	–	–	–	1.51	1.42	1.33	1.26
9	–	–	–	–	–	–	1.57	1.48	1.39	1.32
9-1/2	–	–	–	–	–	–	–	1.54	1.45	1.37
10	–	–	–	–	–	–	–	–	1.50	1.42
10-1/2	–	–	–	–	–	–	–	–	1.56	1.47
11	–	–	–	–	–	–	–	–	–	1.53
11-1/2	–	–	–	–	–	–	–	–	–	1.58

① Interpolate for intermediate values. For example Lr is 1.12 for Size 2080 when the distance is 4-1/4 inches.

NOTE: Based on distance from centerline of load to reducer seal cage.

LSS Overhung Load Ratings

Double Reduction — Ratios 1.50 through 4.57 (lb) ①

Approx. L.S. Shaft RPM	Drive Size					
	2040	2050	2060	2070	2080	2090
2340	1.65	2.04	3.61	4.16	5.06	6.89
1900	1.74	1.86	3.78	4.32	5.09	7.22
1720	1.82	2.17	3.92	4.40	5.21	7.44
1560	1.82	1.96	4.01	4.41	4.85	7.64
1400	1.92	2.29	4.15	4.47	4.96	7.79
1280	1.92	2.08	4.21	4.61	5.00	8.09
1150	2.03	2.42	4.36	4.67	5.12	8.25
1040	2.04	2.45	4.42	4.81	5.29	8.59
940	2.15	2.32	4.58	4.87	5.42	8.73
840	2.20	2.66	4.67	5.12	5.14	9.09
760	2.29	2.53	4.84	5.19	5.26	9.25
640	2.38	2.58	5.02	5.59	5.55	9.77
520	2.53	2.73	5.45	6.28	6.55	10.7
420	2.65	3.14	5.75	6.69	6.96	11.5
350	2.92	3.60	6.15	7.11	7.63	12.2
280 ②	3.10	3.70	6.50	7.70	8.20	13.0

Double, Triple & Quadruple Reduction — Ratios 5.06 through 985.3 (lb) ①

Approx. L.S. Shaft RPM	Drive Size									
	2040	2050	2060	2070	2080	2090	2100	2110	2120	2130
700	1.83	2.53	4.40	5.41	3.93	7.01	8.01	4.63	8.40	11.6
560	1.93	2.68	4.66	5.42	3.95	7.20	8.48	4.90	8.70	12.1
460	2.04	2.83	4.78	5.63	3.90	7.61	8.98	5.18	8.93	12.5
380	2.16	2.99	4.98	5.93	4.13	8.07	9.62	5.71	9.37	13.1
350	2.26	3.12	5.11	6.06	4.72	8.62	9.87	5.70	9.62	14.3
310	2.28	3.17	5.24	6.19	4.37	8.87	10.2	6.24	9.91	13.9
280	2.38	3.30	5.77	6.67	5.15	8.87	10.5	6.06	10.7	14.9
230	2.51	3.50	5.88	6.98	4.80	9.42	11.1	6.65	11.0	15.4
190	2.67	3.70	6.14	7.57	5.46	10.3	11.9	7.13	11.5	16.1
155	2.84	4.02	6.50	8.21	6.35	11.0	12.6	8.04	12.2	17.1
125	3.03	4.37	6.50	8.50	7.48	11.9	13.4	9.06	13.0	18.2
100	3.29	4.74	6.50	8.50	8.90	13.8	14.6	13.4	14.3	19.8
84	3.40	5.12	6.50	8.50	10.2	14.0	15.5	12.4	16.1	22.0
68	3.40	5.25	6.50	8.50	11.0	14.0	16.9	14.5	17.5	22.5
56	3.40	5.25	6.50	8.50	11.0	14.0	17.0	16.8	19.0	22.5
45	3.40	5.25	6.50	8.50	11.0	14.0	17.0	18.5	19.0	22.5
37	3.40	5.25	6.50	8.50	11.0	14.0	17.0	18.5	19.0	22.5
28 ②	3.40	5.25	6.50	8.50	11.0	14.0	17.0	18.5	19.0	22.5

① Published values of overhung load are for loads applied one shaft diameter from the seal cage with a service factor of unity. Where overhung load is proportional to torque (i.e. pinion, sprocket or sheave applications) an appropriate service factor should be considered in the overhung load calculation.

② The last overhung load value in each drive size column applies to all lower output speeds for that drive. Published ratings are based on a combination of the most unfavorable conditions of loading. For higher ratings, refer full data to Factory.

NOTE: Multiply values listed by 1000. Consult Factory for higher overhung load ratings.

HSS Overhung Load Ratings

Double Reduction (lb) ①

High-Speed Shaft RPM ②	Nominal Ratios	Approx. L. S. Shaft RPM	Drive Size									
			With or Without Backstop						Without Backstop ③			
			2040	2050	2060	2070	2080	2090	2100	2110	2120	2130
1170	5.06	230	10	250	0	570	10	220	1290	–	–	–
	6.20	190	0	220	0	660	20	290	1400	–	–	–
	7.59	155	30	440	10	800	620	380	1400	–	–	–
	9.30	125	50	500	290	800	440	550	1400	1430	–	–
	11.39	100	100	300	540	800	1050	1250	1400	1500	1300	1370
	13.95	84	190	410	600	800	1050	1250	1400	1500	1500	1750
	17.09	68	350	490	600	800	1050	1250	1400	1500	1500	1750
	20.93	56	400	500	600	800	1050	1250	1400	1500	1500	1750
	25.63	45	110	500	600	800	1050	1250	1400	1500	1500	1390
870	5.06	175	150	500	0	800	580	1070	1400	–	–	–
	6.20	140	130	500	0	800	690	1080	1400	–	–	–
	7.59	115	90	500	340	800	1050	1040	1400	–	–	–
	9.30	95	40	500	600	800	1050	1210	1400	1500	–	–
	11.39	77	100	300	600	800	1050	1250	1400	1500	1500	1750
	13.95	62	190	400	600	800	1050	1250	1400	1500	1500	1750
	17.09	50	400	480	600	800	1050	1250	1400	1500	1500	1750
	20.93	42	400	500	600	800	1050	1250	1400	1500	1500	1750
	25.63	34	280	500	600	800	1050	1250	1400	1500	1500	1750
720	5.06	140	240	500	0	800	1050	1250	1400	–	–	–
	6.20	115	230	500	0	800	1050	1250	1400	–	–	–
	7.59	95	200	500	580	800	1050	1250	1400	–	–	–
	9.30	77	30	500	600	800	1050	1250	1400	1500	–	–
	11.39	62	90	290	600	800	1050	1250	1400	1500	1500	1750
	13.95	50	180	400	600	800	1050	1250	1400	1500	1500	1750
	17.09	42	400	480	600	800	1050	1250	1400	1500	1500	1750
	20.93	34	400	500	600	800	1050	1250	1400	1500	1500	1750
	25.63	28	390	500	600	800	1050	1250	1400	1500	1500	1750
580	5.06	115	350	500	110	800	1050	1250	1400	–	–	–
	6.20	95	340	500	190	800	1050	1250	1400	–	–	–
	7.59	77	330	500	600	800	1050	1250	1400	–	–	–
	9.30	62	20	500	600	800	1050	1250	1400	1500	–	–
	11.39	50	90	290	600	800	1050	1250	1400	1500	1500	1750
	13.95	42	180	400	600	800	1050	1250	1400	1500	1500	1750
	17.09	34	400	480	600	800	1050	1250	1400	1500	1500	1750
	20.93	28	400	500	600	800	1050	1250	1400	1500	1500	1750
	25.63	22	400	500	600	800	1050	1250	1400	1500	1500	1750
31.39	18	400	500	600	800	1050	1250	1400	1500	1500	1750	

① Published values of overhung load are for loads applied one shaft diameter from the seal cage with a service factor of unity. Where overhung load is proportional to torque (i.e. pinion, sprocket or sheave applications) an appropriate service factor should be considered in the overhung load calculation.

② For input speeds higher than 1170 rpm, refer to Catalog 311-112.

③ For high-speed shaft overhung load for Type FC drives with backstop, refer to table on page 53.

NOTE: Consult Factory for higher overhung load ratings.

HSS Overhung Load Ratings

Triple Reduction (lb) ①

High-Speed Shaft RPM ②	Nominal Ratios	Approx. L.S. Shaft RPM	Drive Size									
			With or Without Backstop						Without Backstop ③			
			2040	2050	2060	2070	2080	2090	2100	2110	2120	2130
1170	38.44	30	270	300	400	270	580	280	700	800	900	800
	47.08	25	270	300	400	530	580	620	700	800	900	810
	57.66	20	270	300	400	460	580	620	700	800	900	1000
	70.62	16.5	270	300	400	530	580	620	700	800	900	1000
	86.50	13.5	270	300	400	530	580	620	700	800	900	1000
	105.9	11.0	270	300	400	530	580	620	700	800	900	1000
	129.7	9.0	270	300	350	400	580	620	700	800	900	1000
	158.9	7.5	270	300	210	360	580	620	700	800	900	1000
194.6	6.0	–	–	260	450	–	620	–	–	–	–	
870	38.44	22	270	300	400	460	580	620	700	800	900	790
	47.08	18	270	300	400	530	580	620	700	800	900	790
	57.66	15	270	300	400	460	580	620	700	800	900	1000
	70.62	12.5	270	300	400	520	580	620	700	800	900	1000
	86.50	10.0	270	300	400	530	580	620	700	800	900	1000
	105.9	8.3	270	300	400	530	580	620	700	800	900	1000
	129.7	6.8	270	300	400	530	580	620	700	800	900	1000
	158.9	5.5	270	300	200	360	580	620	700	800	900	1000
194.6	4.5	–	–	260	450	–	620	–	–	–	–	
720	38.44	18	270	300	400	530	580	620	700	800	900	800
	47.08	15	270	300	400	530	580	620	700	800	900	800
	57.66	12.5	270	300	400	460	580	620	700	800	900	1000
	70.62	10.0	270	300	400	530	580	620	700	800	900	1000
	86.50	8.3	270	300	400	530	580	620	700	800	900	1000
	105.9	6.8	270	300	400	530	580	620	700	800	900	1000
	129.7	5.5	270	300	400	530	580	620	700	800	900	1000
	158.9	4.5	270	300	210	360	580	620	700	800	900	1000
194.6	3.8	–	–	260	450	–	620	–	–	–	–	
580	38.44	15.0	270	300	400	530	580	620	700	800	900	780
	47.08	12.5	270	300	400	530	580	620	700	800	900	780
	57.66	10.0	270	300	400	470	580	620	700	800	900	1000
	70.62	8.3	270	300	400	530	580	620	700	800	900	1000
	86.50	6.8	270	300	400	530	580	620	700	800	900	1000
	105.9	5.5	270	300	400	530	580	620	700	800	900	1000
	129.7	4.5	270	300	400	530	580	620	700	800	900	1000
	158.9	3.8	270	300	200	360	580	620	700	800	900	1000
194.6	3.0	–	–	260	450	–	620	–	–	–	–	

① Published values of overhung load are for loads applied one shaft diameter from the seal cage with a service factor of unity. Where overhung load is proportional to torque (i.e. pinion, sprocket or sheave applications) an appropriate service factor should be considered in the overhung load calculation.

② For input speeds higher than 1170 rpm, refer to Catalog 311-112.

③ For high-speed shaft overhung load for Type FC drives with backstop, refer to table on page 53.

NOTE: Consult Factory for higher overhung load ratings.

HSS Overhung Load Ratings

Quadruple Reduction (lb) ①

High-Speed Shaft RPM ②	Nominal Ratios	Approx. L.S. Shaft RPM	Drive Size								
			With or Without Backstop					Without Backstop ③			
			2050	2060	2070	2080	2090	2100	2110	2120	2130
1170	194.6	6.0	150	–	–	230	–	470	590	650	340
	238.4	5.0	150	150	140	230	240	520	150	650	300
	291.9	4.0	150	150	160	230	410	520	240	650	530
	357.5	3.2	150	150	170	230	440	520	300	650	690
	437.9	2.7	150	150	170	230	440	520	590	650	700
	536.3	2.2	150	150	170	230	440	520	590	650	700
	656.8	1.8	150	150	170	230	440	520	590	650	700
	804.5	1.5	150	150	170	230	440	520	590	650	700
870	194.6	4.5	150	–	–	230	–	470	590	650	700
	238.4	3.8	150	150	140	230	240	520	150	650	650
	291.9	3.0	150	150	160	230	410	520	240	650	590
	357.5	2.5	150	150	170	230	440	520	300	650	700
	437.9	2.0	150	150	170	230	440	520	590	650	700
	536.3	1.6	150	150	170	230	440	520	590	650	700
	656.8	1.3	150	150	170	230	440	520	590	650	700
	804.5	1.1	150	150	170	230	440	520	590	650	700
720	194.6	3.8	150	–	–	230	–	470	590	650	700
	238.4	3.0	150	150	140	230	240	520	150	650	700
	291.9	2.5	150	150	160	230	410	520	240	650	590
	357.5	2.0	150	150	170	230	440	520	300	650	700
	437.9	1.6	150	150	170	230	440	520	590	650	700
	536.3	1.3	150	150	170	230	440	520	590	650	700
	656.8	1.1	150	150	170	230	440	520	590	650	700
	804.5	0.90	150	150	170	230	440	520	590	650	700
580	194.6	3.0	150	–	–	230	–	470	590	650	700
	238.4	2.5	150	150	140	230	240	520	150	650	700
	291.9	2.0	150	150	160	230	410	520	230	650	590
	357.5	1.6	150	150	170	230	440	520	300	650	700
	437.9	1.3	150	150	170	230	440	520	590	650	700
	536.3	1.1	150	150	170	230	440	520	590	650	700
	656.8	0.90	150	150	170	230	440	520	590	650	700
	804.5	0.75	150	150	170	230	440	520	590	650	700
985.3	0.60	150	150	170	230	440	520	590	650	700	

① Published values of overhung load are for loads applied one shaft diameter from the seal cage with a service factor of unity. Where overhung load is proportional to torque (i.e. pinion, sprocket or sheave applications) an appropriate service factor should be considered in the overhung load calculation.

② For input speeds higher than 1170 rpm, refer to Catalog 311-112.

③ For high-speed shaft overhung load for Type FC drives with backstop, refer to table on page 53.

NOTE: Consult Factory for higher overhung load ratings.

HSS Overhung Load Ratings

Double, Triple & Quadruple Reduction with External Backstops (lb) ①

High-Speed Shaft RPM ②	Nominal Ratios	Approx. L.S. Shaft RPM	Drive Size			
			2100	2110	2120	2130
FC2 Double Reduction						
1170	5.06	230	560	—	—	—
	6.20	190	630	—	—	—
	7.59	155	630	—	—	—
	9.30	125	630	710	—	—
	11.39	100	630	710	650	680
	13.95	84	630	710	720	870
	17.09	68	630	710	720	870
	20.93	56	630	710	720	870
	25.63	45	630	710	720	700
	31.39	37	630	710	720	870
870	5.06	175	615	—	—	—
	6.20	140	630	—	—	—
	7.59	115	630	—	—	—
	9.30	95	630	710	—	—
	11.39	77	630	710	720	870
720	5.06	140	630	—	—	—
	6.20	115	630	—	—	—
	7.59	95	630	—	—	—
	9.30	77	630	710	—	—
	11.39	62	630	710	720	870
580	5.06	115	630	—	—	—
	6.20	95	630	—	—	—
	7.59	77	630	—	—	—
	9.30	62	630	710	—	—
	11.39	50	630	710	720	870
FC3 Triple Reduction						
1170	38.44	30	280	330	400	360
	47.08	25	280	330	400	450
	38.44	22	280	330	400	360
870	47.08	19	280	330	400	380
	57.60	15	280	330	400	450
FC4 Quadruple Reduction						
1170	194.6	6.0	175	230	260	240
	238.4	5.0	190	60	260	210
	291.9	4.0	190	95	260	240
	357.5	3.2	190	120	260	280
	437.9	2.7	190	230	260	280

① Published values of overhung load are for loads applied one shaft diameter from the backstop with a service factor of unity. Where overhung load is proportional to torque (i.e. pinion, sprocket or sheave applications) an appropriate service factor should be considered in the overhung load calculation. Refer to Factory for OHL ratings of drives with both a fan and an external backstop.

② For input speeds higher than 1170 rpm, refer to Catalog 311-112.

NOTE: Consult Factory for higher overhung load ratings.

LSS Thrust Loads

Thrust Loads — External thrust loads are often imposed upon gear drive bearings by agitators, mixers and similar equipment through solid couplings and also some flexible couplings. Calculate the direction and magnitude of the thrust and check the result against the tabulated thrust value.

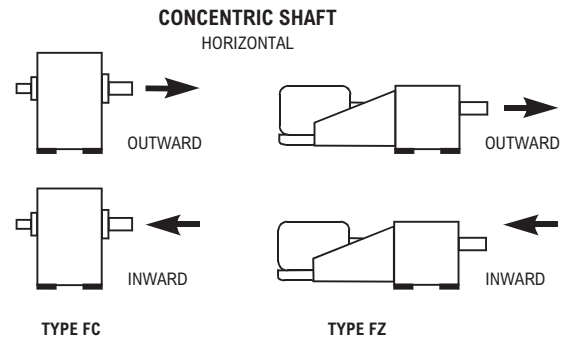

LSS Thrust Load Capacity

Ratios 1.50 through 4.57 (lb) ①②

Approx. L.S. Shaft RPM	Drive Size			
	2040	2050	2060	2070
2340	1.80	2.14	3.25	3.88
1900	1.80	1.93	3.38	3.93
1720	1.80	2.22	3.50	3.75
1560	1.80	2.29	3.50	3.74
1400	1.80	2.30	3.50	3.48
1280	1.80	2.08	3.50	3.82
1150	1.80	2.30	3.50	3.51
1040	1.80	2.30	3.50	3.90
940	1.80	2.30	3.50	3.55
840	1.80	2.30	3.50	4.14
760	1.80	2.30	3.50	3.82
640	1.80	2.30	3.50	4.90
520	1.80	2.30	3.50	4.90
420	1.80	2.30	3.50	4.90
350	1.80	2.30	3.50	4.90
280 ③	1.80	2.30	3.50	4.90

Ratios 5.06 through 985.3 (lb) ①②

Approx. L.S. Shaft RPM	Drive Size									
	2040	2050	2060	2070	2080	2090	2100	2110	2120	2130
700	1.79	2.30	3.50	4.90	3.41	4.37	6.06	2.48	6.53	9.95
560	1.80	2.30	3.50	4.90	2.73	4.45	6.42	2.62	6.61	10.1
460	1.80	2.30	3.50	4.90	2.67	4.70	6.80	2.77	6.53	10.4
380	1.80	2.30	3.50	4.90	3.06	4.98	7.27	3.07	6.77	10.8
350	1.80	2.30	3.50	4.90	4.22	5.38	7.46	3.05	8.04	11.3
310	1.80	2.30	3.50	4.90	2.99	5.53	7.76	3.37	7.10	11.3
280	1.80	2.30	3.50	4.90	3.35	5.48	7.94	3.24	8.13	11.3
230	1.80	2.30	3.50	4.90	3.28	5.82	8.42	3.57	8.04	11.3
190	1.80	2.30	3.50	4.90	3.79	6.46	8.91	3.84	8.34	11.3
155	1.80	2.30	3.50	4.90	4.50	6.86	9.20	4.36	8.73	11.3
125	1.80	2.30	3.50	4.90	5.38	7.49	9.20	4.95	9.29	11.3
100	1.80	2.30	3.50	4.90	5.40	8.00	9.20	7.87	10.3	11.3
84	1.80	2.30	3.50	4.90	5.40	8.00	9.20	6.99	10.3	11.3
68	1.80	2.30	3.50	4.90	5.40	8.00	9.20	8.40	10.3	11.3
56	1.80	2.30	3.50	4.90	5.40	8.00	9.20	10.3	10.3	11.3
45	1.80	2.30	3.50	4.90	5.40	8.00	9.20	10.3	10.3	11.3
37	1.80	2.30	3.50	4.90	5.40	8.00	9.20	10.3	10.3	11.3
28 ③	1.80	2.30	3.50	4.90	5.40	8.00	9.20	10.3	10.3	11.3

① Thrust inward or outward. Multiply values listed by 1000.

② Thrust capacities are for pure thrust loads. If thrust and overhung loads are applied simultaneously, or loads exceed these capacities, refer to Factory.

③ The last thrust capacity value in each drive size column applies to all lower output speeds for that drive.

Exact Ratios

Double Reduction ①

Nominal Ratio	Drive Size									
	2040	2050	2060	2070	2080	2090	2100	2110	2120	2130
1.50	1.465	1.476	1.548	–	1.561①	1.504	–	–	–	–
1.84	1.820	1.822	1.833	1.783	1.887	1.801	–	–	–	–
2.03	2.057	2.028	2.027	2.062	2.055	2.089	–	–	–	–
2.25	2.191	2.252	2.295	2.197	2.299	2.257	–	–	–	–
2.49	2.475	2.504	2.537	2.541	2.504	2.503	–	–	–	–
2.76	2.723	2.702	2.827	2.683	2.792	2.756	–	–	–	–
3.05	3.076	3.095	3.126	3.103	3.041	3.137	–	–	–	–
3.38	3.279	3.283	3.400	3.211 ①	3.262	3.428	–	–	–	–
3.74	3.705	3.714	3.759	3.713	3.553 ①	3.830	–	–	–	–
4.13	4.120	4.001	4.130	3.954 ①	4.067	4.164	–	–	–	–
4.57	4.655	4.512	4.567	4.573	4.430	4.763 ①	–	–	–	–
5.06	4.929	4.980	4.998	4.996	5.161	5.050	5.071	–	–	–
6.20	6.122	6.147	6.256	6.155	6.290	6.050	6.417	–	–	–
7.59	7.368	7.598	7.708	7.517	7.638	7.581	7.641	–	–	–
9.30	9.158	9.119	9.269	8.996	8.923 ①	9.257	9.218	9.463	–	–
11.39	11.03	11.08	11.26	11.08	11.13	11.51	11.58	11.46	11.54	11.85
13.95	13.86	13.50	13.72	13.50	13.67	13.98	14.01	13.94	14.00	14.42
17.09	16.83	16.65	17.19	17.33	17.34	16.78	17.29	17.01	17.37	17.15
20.93	19.81 ①	20.56	21.13	20.54	20.98	21.01	21.58	20.76	21.12	21.25
25.63	25.25	25.27	25.63	25.12	25.17	25.66	25.55	25.39	25.91	25.36
31.39	29.43 ①	30.16	31.69	31.08	31.15	31.15	31.21	31.12	31.89	30.89

Triple Reduction ①

Nominal Ratio	Drive Size									
	2040	2050	2060	2070	2080	2090	2100	2110	2120	2130
38.44	38.08	37.57	38.46	37.83	38.88	39.51	40.24 ①	38.38	39.36	39.60
47.08	45.86	45.64	46.65	46.27	47.23	48.23	48.39	46.56	47.71	47.26
57.66	57.62	55.63	56.62	56.63	57.56	57.53	57.29	56.56	57.02	57.30
70.62	69.99	68.61	70.64	71.14	69.64	69.86	71.64	68.94	68.05	68.47
86.50	82.37 ①	84.70	85.69	86.43	87.65	85.18	88.36	86.02	88.15	81.72 ①
105.9	105.0	104.1	106.5	101.7	107.7	103.4	104.6	104.9	107.0	105.9
129.7	125.0	127.7	131.3	129.6	130.4	129.7	133.8	128.2	128.9	128.5
158.9	159.4	156.9	156.7	151.1	156.4	157.5	158.4	155.7	158.2	154.8
194.6	–	–	190.1	184.8 ①	–	193.6	–	–	–	–

Quadruple Reduction ①

Nominal Ratio	Drive Size									
	2050	2060	2070	2080	2090	2100	2110	2120	2130	
194.6	187.5	–	–	192.3	–	202.3	192.9	197.7	199.0	
238.4	231.5	239.6	236.6	237.8	236.7	243.7	234.3	240.1	237.4	
291.9	286.1	296.3	292.6	291.5	284.5	306.1	285.6	292.7	288.4	
357.5	343.3	363.2	358.7	360.7	351.9	371.9	352.3	361.0	351.4	
437.9	417.1	449.4	443.8	436.4	431.4	437.6	434.9	445.7	433.5	
536.3	508.3 ①	543.0	542.7	523.5	533.7	518.1	531.7	535.7	535.1	
656.8	627.0	649.5	641.4	638.7	644.9	660.4	653.6	657.2	643.3	
804.5	774.1	795.9	785.9	772.8	783.1	844.5	791.4	783.6	782.8	
985.3	951.5	965.5	961.2	927.2 ①	945.2	999.9	967.6	961.3	940.9	

① Except where noted with an ①, exact ratios are within ±4% for double and triple reduction, and ±5% of quadruple reduction nominal ratios.

Availability & Compatibility of Accessories

Drive Sizes 2040 & 2050	Motor Mount	Motor Bracket	C-Face Adapter	Motor Plate	Slide Base	Slide Rails	Internal Backstop	Reliability
Motor Mount	OK ⑦	...	OK	OK⑩
Motor Bracket	OK	...	OK	OK
C-Face Adapter	OK	...	OK	OK
Motor Plate	OK⑨	OK	OK
Slide Base	OK ⑦	OK	OK	OK	OK
Slide Rails	OK⑨	OK	OK
Internal Backstop	OK	OK	OK	OK	OK	OK	OK	OK
Reliability	OK⑩	OK	OK	OK	OK	OK	OK	OK

Drive Sizes 2060 & 2130	Motor Mount	Motor Bracket	C-Face Adapter	Motor Plate	Slide Base	Slide Rails	External Backstop ①	Internal Backstop ②	Shaft Fans	Electric Fan – Right Hand ⑧	Electric Fan – Left Hand ⑧	Cooling Tubes	Pump & Cooler	Ext. Backstop & Fan	Reliability
Motor Mount	OK ⑦	OK	...	OK ③	OK ④	OK	OK	...	OK⑩
Motor Bracket	OK	...	OK	OK	OK ⑩	OK	OK	OK	OK	...	OK
C-Face Adapter	OK	OK	...	OK	OK	OK	OK	...	OK
Motor Plate	OK⑨	OK	OK	OK	OK	OK	OK	OK	OK	OK
Slide Base	OK ⑦	OK	OK	OK	OK	OK	OK ⑤	OK ⑤	...	OK	OK	OK
Slide Rails	OK ⑨	OK	OK	OK	OK	OK	OK	OK	OK	OK
External Backstop①	...	OK	...	OK	OK	OK	OK ⑥	OK ⑥	OK	OK	...	OK
Internal Backstop②	OK	OK	OK	OK	OK	OK	...	OK	OK	OK	OK	OK	OK	...	OK
Shaft Fan	...	OK ⑩	...	OK	OK	OK	...	OK	OK
Electric Fan – Right Hand⑧	OK ③	OK	OK	OK	OK ⑤	OK	OK ⑥	OK	OK
Electric Fan – Left Hand⑧	OK ④	OK	OK	OK	OK ⑤	OK	OK ⑥	OK	OK
Cooling Tubes	OK	OK	OK	OK	...	OK	OK	OK
Pump & Cooler	OK	OK	OK	OK	OK	OK	OK	OK	OK
Ext. Backstop & Fan	OK	OK	OK	OK
Reliability	OK⑩	OK	OK	OK	OK	OK	OK	OK	OK	OK	OK	...	OK	OK	OK

- ① External backstops used only on 2100 thru 2130.
- ② Internal backstops used only on 2040 thru 2090.
- ③ Motor mount mounted at 9 o'clock position only.
- ④ Motor mount mounted at 3 and 12 o'clock positions only.
- ⑤ Drive sizes 2080 thru 2130 only.
- ⑥ Electric fan is not available on drives with #60 backstop.
- ⑦ Must check for clearance between L.S. shaft sprocket and motor mount. When motor mount used in 3 & 9 o'clock position, must check for clearance between the motor mount and slide base Drive Sizes 2040 thru 2080 only.
- ⑧ Left and right hand as viewed when facing H.S. shaft.
- ⑨ Use of slide rails requires a motor plate.
- ⑩ Bolted brackets (designed for 326T frame and smaller) cannot be used with shaft fans due to interference.
- ⑪ Will work when 3 & 9 o'clock positions are opposing reliability package on all. 12 o'clock position will not work without modification.

Double, Triple & Quadruple Reduction Dimensions

Type FC— Sizes 2040 and 2050 / Dimensions—Inch

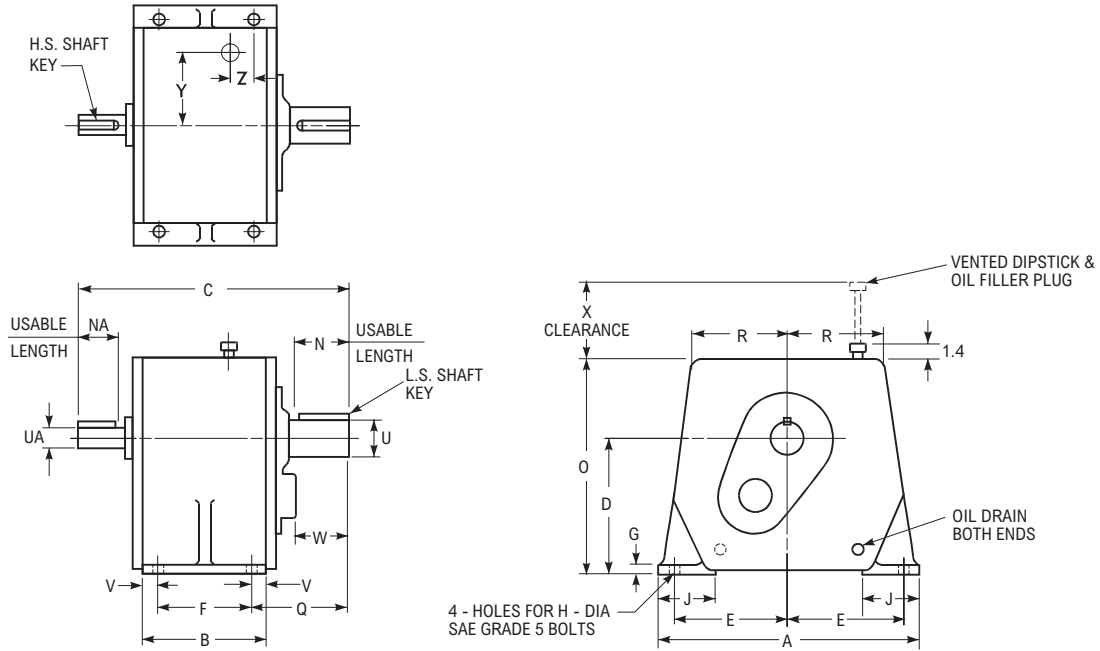

Dimensions (in)

Drive Size ①	A	B	D	E	F	G	H	J	N	O	Q	R	Low-Speed Shaft ②		W ③		X	Y	Z	Max AA	Wt (lb) Ave	
													U	Key	W/O	With						
2040	15.00	7.90	8.50	6.60	6.10	0.80	0.750	4.3	4.00	12.92	6.86	5.9	2.0000	0.500 x 0.500 x 3.50	0.90	3.54	3.24	7.50	2.90	2.06	17.98	200
2050	16.60	8.98	9.60	7.30	7.10	1.00	0.875	4.5	5.00	14.52	8.10	6.7	2.5000	0.625 x 0.625 x 4.50	0.94	4.16	3.92	8.70	3.40	2.90	18.98	340

Drive Size ①	Double Reduction — FC2/FZ2				Triple Reduction — FC3/FZ3				Quadruple Reduction — FC4/FZ4			
	C	NA	High-Speed Shaft ②		C	NA	High-Speed Shaft ②		C	NA	High-Speed Shaft ②	
			UA	Key			UA	Key			UA	Key
2040	18.44	2.76	1.3750	0.312 x 0.312 x 2.50	18.44	2.76	1.3750	0.312 x 0.312 x 2.50	—	—	—	—
2050	21.54	3.26	1.6250	0.375 x 0.375 x 3.00	21.54	3.26	1.6250	0.375 x 0.375 x 3.00	19.98	2.00	1.0000	0.250 x .0250 x 1.50

- ① Dimensions are for reference only and are subject to change without notice unless certified. Drives are for horizontal floor-mounted operation unless specifically stated otherwise. Refer to Factory for other mountings.
- ② Shaft diameters under 3" are held to limits of +.0000", -.0005". Shaft keyseat depth is one-half of key height.
- ③ Dimension W is clearance with and without (W/O) internal backstop. For drive with backstop, indicate low-speed shaft rotation when viewing drive from the end of the low-speed shaft.

Double, Triple & Quadruple Reduction Dimensions

Type FZ — Sizes 2040 and 2050 / Dimensions—Inch

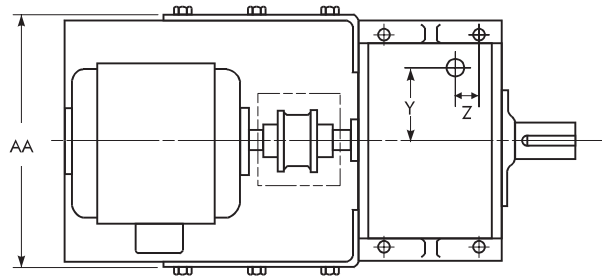

DIMENSIONS ON PAGE 57
(CA IN TABLE BELOW)

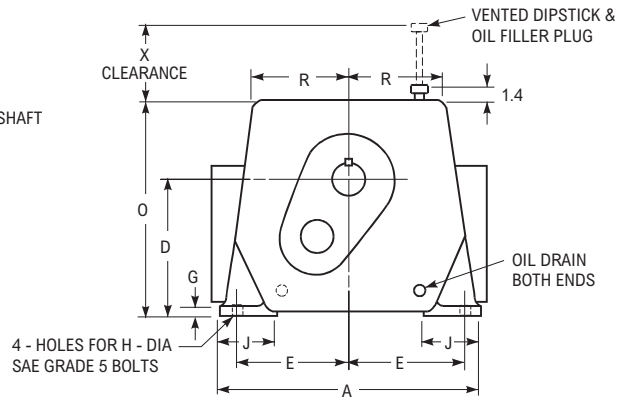
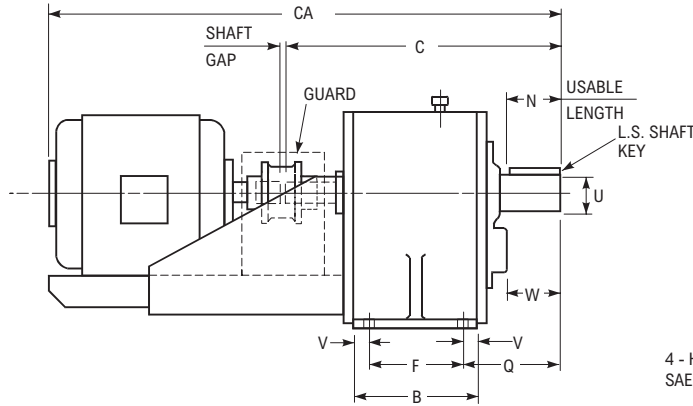

Dimensions (in)

Drive Size	Average Weight of Drive Only (lb) ②	Max. NEMA T & U Frame Size ③ ④	CA – Approximate Overall Length With Motor and Type T Coupling ①												
			Motor Frame Size ③												
			143T	145T	182T	184T	213T	215T	254T	256T	284TS	286TS	324TS	326TS	
Open Motors															
2040	200	286	33.9	33.9	33.9	33.9	35.0	36.2	39.9	41.5	43.9	43.9	–	–	
2050	340	326	36.2	36.2	36.2	36.2	37.5	39.0	42.4	44.2	46.2	46.2	48.8	48.8	
TEFC Motors															
2040	200	286	30.7	31.2	33.2	34.2	39.0	39.0	45.2	45.2	46.3	46.3	–	–	
2050	340	326	33.7	34.2	36.3	37.3	41.6	41.6	47.8	47.8	48.9	48.9	52.9	52.9	

Approximate Weights

Falk™ Motor Brackets/Couplings and Motors (lb)

HP	1	1-1/2	2	3	5	7-1/2	10	15	20	25	30	40	50	60	75	100	125	150	200	
Frame ③	143T	145T	145T	182T	184T	213T	215T	254T	256T	284T	286T	324T	326T	364T	365T	404T	405T	444T	445T	
Drive Size	Bracket & Coupling Weights																			
2040-2070	60	60	60	60	60	65	65	80	80	100	100	110	110	165	180	270	270	–	–	
2080-2090	65	65	65	65	75	80	80	95	100	115	115	120	120	165	180	270	285	340	–	
2100-2130	70	70	70	85	85	90	90	110	110	120	120	130	135	310	310	375	375	445	485	
1750 RPM Motor Weights																				
TEFC General Purpose Motor	30	35	40	60	80	120	165	230	265	360	380	490	526	650	780	1050	1505	1530	1700	
TEFC High Efficiency Motor	30	45	55	70	85	125	170	235	300	450	440	560	650	785	870	1150	1520	1710	1850	
Open Motor	30	35	35	60	70	120	145	190	215	255	315	370	400	575	640	810	895	1195	1375	

① CA dimensions are approximate and may vary with motor manufacturer.

② Weight shown is for Type FC drive. For Type FZ drive weight, add average drive weight to approximate weight.

③ Brackets for Sizes 2040 thru 2050 will accept either T, TS, U or US frame motors. Do not exceed the gear drive ratings shown in the selection tables. Standard length and semi-standard length blank bracket dimensions are covered in Engineering 317-315.

④ Refer to pages 5 and 6 for instructions when using other than T-frame motors.

Double, Triple & Quadruple Reduction Dimensions

Type FC — Sizes 2060 to 2090 / Dimensions—Inch

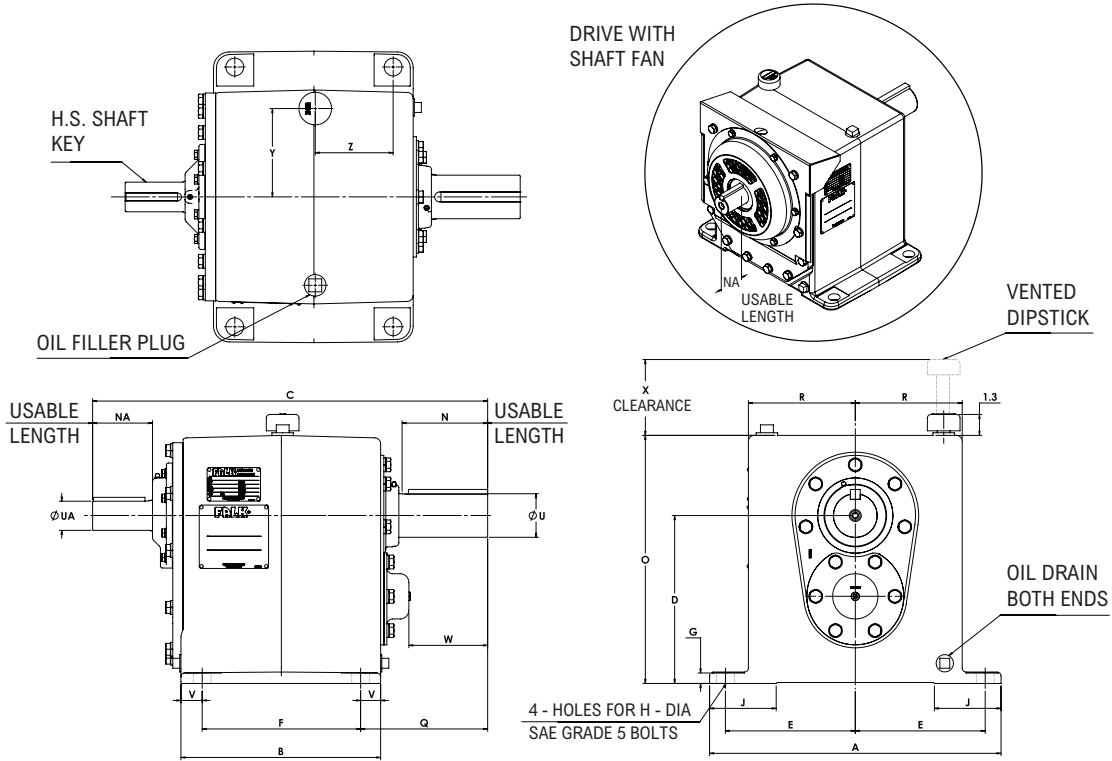

Dimensions (in)

Drive Size ①	A	B	D	E	F	G	H	J	K	N	O	Q	R	Low-Speed Shaft ②		V	W ④		X	Y	Z	Average Wt (lb)
														U	Key		W/O	With				
2060	18.4 ⑤	12.00	10.60	8.20	10.00	0.66	1.125	4.2	③	5.50	15.66	8.02	6.8	2.750	0.625 X 0.625 X 5.00	1.26	4.97	4.55	11.2	5.58	4.92	345
2070	21 ⑤	14.31	11.66	9.30	11.30	0.66	1.125	4.5	③	6.50	17.22	9.20	7.9	3.250	0.750 X 0.750 X 6.00	1.5	5.81	5.12	12.3	6.60	5.66	487
2080	23 ⑤	16.63	12.78	10.20	13.20	0.78	1.250	5.5	③	7.00	18.98	10.02	8.7	3.500	0.875 X 0.875 X 6.50	1.6	6.4	5.91	13.4	6.95	6.71	704
2090	26.00	18.27	15.74	11.40	14.30	0.90	1.500	7.0	③	8.00	23.06	11.51	9.6	4.000	1.000 X 1.000 X 7.00	2.0	7.55	6.8	15.6	8.25	7.21	965

Drive Size ①	Double Reduction — FC2					Triple Reduction — FC3					Quadruple Reduction — FC4				
	C	NA		High-Speed Shaft ②		C	NA	High-Speed Shaft ②		C	NA	High-Speed Shaft ②			
		W/O Shaft Fan	With Shaft Fan	UA	Key			UA	Key			UA	Key		
2060	24.94	3.69	2.38	1.8750	0.500 X 0.500 X 3.25	24.34	3.26	1.5000	0.375 x 0.375 x 3.00	23.58	2.50	1.2500	0.250 x 0.250 x 2.25		
2070	28.35	4.26	2.94	2.1250	0.500 X 0.500 X 3.75	27.28	3.18	1.7500	0.375 x 0.375 x 3.00	26.54	2.44	1.3750	0.312 x 0.312 x 2.50		
2080	31.7	4.50	3.16	2.2500	0.500 X 0.500 X 4.00	30.67	3.78	2.0000	0.500 x 0.500 x 3.50	29.95	3.05	1.6250	0.375 x 0.375 x 3.00		
2090	35.09	4.94	3.12	2.5000	0.625 X 0.625 x 4.00	33.69	3.92	2.0000	0.500 x 0.500 x 3.50	32.96	3.38	1.6250	0.375 x 0.375 x 3.00		

- ① Dimensions are for reference only and are subject to change without notice unless certified. Drives are for horizontal floor-mounted operation unless specifically stated otherwise. Refer to Factory for other mountings.
- ② Shaft diameters under 3" are held to limits of +.0000", -.0005". Shaft diameters 3" and over are held to limits of +.000", -.001". Shaft keyseat depth is one-half of key height.
- ③ Drive Sizes 2060 thru 2090 have foundation pads full length of base.
- ④ Dimension W is clearance with and without (W/O) internal backstop. For Sizes 2100 thru 2130FC, an external backstop is mounted on an extended high-speed shaft; see 315-810 for details. For drive with backstop, indicate low-speed shaft rotation when viewing drive from the end of the low-speed shaft.
- ⑤ Allow clearance for the following bracket widths (Type FZ): Size 2060 with 364 and 365 frame motors, 19.88; Size 2070 with 404 and 405 frame motors, 22.78; Size 2080 with 444 and 445 frame motors, 25.06; Size 2100 with 364 and 445 frame motors, 28.50.

Double, Triple & Quadruple Reduction Dimensions

Type FC — Sizes 2100 to 2130 / Dimensions—Inch

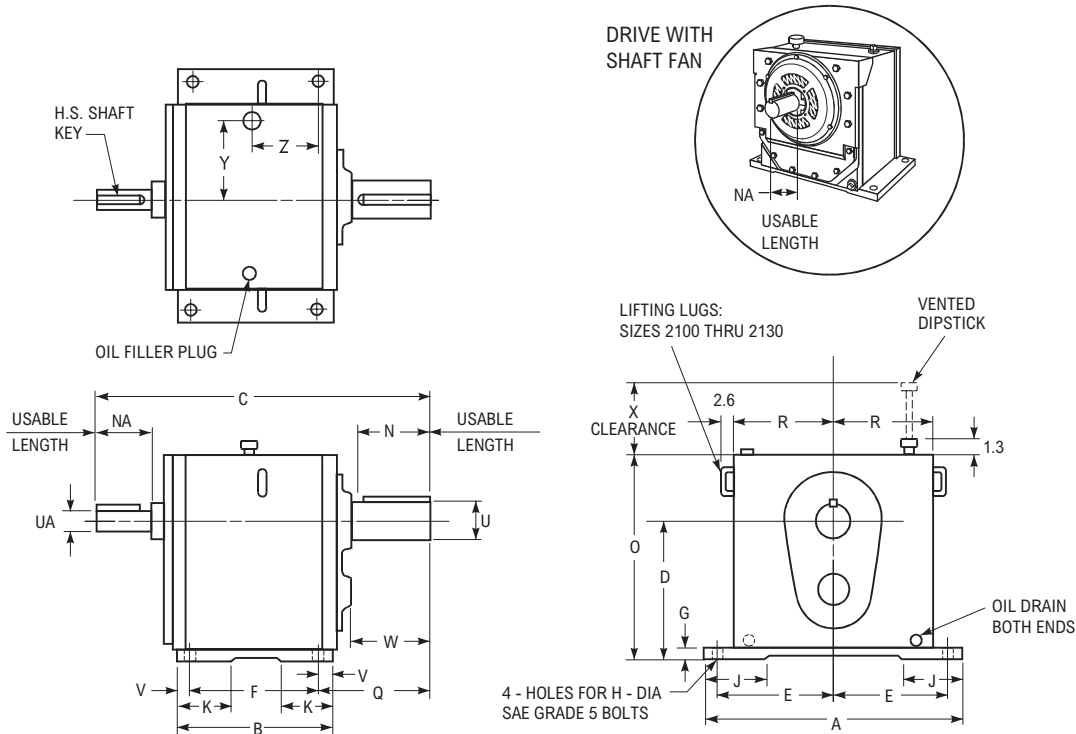

Dimensions (in)

Drive Size ①	A	B	D	E	F	G	H	J	K	N	O	Q	R	Low-Speed Shaft ②		V	W ③		X	Y	Z	Average Wt (lb)
														U	Key		W/O	With				
2100	27.60 ④	19.16	17.40	12.20	14.96	1.00	1.500	9.0	7.0	9.00	26.00	13.14	10.7	4.500	1.000 x 1.000 x 8.50	2.1	9.54	③	15.9	9.06	7.56	1320
2110	29.40	21.48	19.50	13.10	17.28	1.00	1.500	9.0	7.0	9.50	28.80	13.72	11.6	5.000	1.250 x 1.250 x 8.50	2.1	10.22	③	17.2	9.90	8.06	1560
2120	32.48	23.60	21.90	14.44	18.80	1.24	1.750	9.0	7.0	10.00	32.50	14.58	12.6	5.500	1.250 x 1.250 x 9.00	2.4	10.68	③	19.0	10.62	9.36	2210
2130	34.00	25.10	24.70	15.20	19.30	1.24	1.750	9.0	7.0	11.00	36.20	16.16	13.5	6.000	1.500 x 1.500 x 10.00	2.9	11.78	③	20.4	11.50	9.52	2900

Drive Size ①	Double Reduction — FC2					Triple Reduction — FC3					Quadruple Reduction — FC4			
	C	NA		High-Speed Shaft ②		C	NA		High-Speed Shaft ②		C	NA	High-Speed Shaft ②	
		W/O Shaft Fan	With Shaft Fan	UA	Key		W/O Shaft Fan	With Shaft Fan	UA	Key			UA	Key
2100	38.50	5.26	3.35	2.7500	0.625 x 0.625 x 4.75	37.14	4.00	2.34	2.1250	0.500 x 0.500 x 3.50	36.66	3.76	1.8750	0.500 x 0.500 x 3.25
2110	42.02	5.62	3.55	3.0000	0.750 x 0.750 x 5.00	40.10	4.00	2.58	2.1250	0.500 x 0.500 x 3.50	39.62	3.50	1.8750	0.500 x 0.500 x 3.00
2120	45.38	6.26	4.09	3.2500	0.750 x 0.750 x 5.50	43.40	4.26	2.54	2.2500	0.500 x 0.500 x 3.75	42.62	3.62	2.0000	0.500 x 0.500 x 3.25
2130	48.58	6.76	4.51	3.5000	0.875 x 0.875 x 6.00	45.98	4.26	2.54	2.2500	0.500 x 0.500 x 3.75	45.20	3.62	2.0000	0.500 x 0.500 x 3.25

- ① Dimensions are for reference only and are subject to change without notice unless certified. Drives are for horizontal floor-mounted operation unless specifically stated otherwise. Refer to Factory for other mountings.
- ② Shaft diameters under 3" are held to limits of +.0000", -.0005". Shaft diameters 3" and over are held to limits of +.000", -.001". Shaft keyseat depth is one-half of key height.
- ③ Dimension W is clearance with and without (W/O) internal backstop. For Sizes 2100 thru 2130FC, an external backstop is mounted on an extended high-speed shaft; see 315-810 for details. For drive with backstop, indicate low-speed shaft rotation when viewing drive from the end of the low-speed shaft.
- ④ Allow clearance for the following bracket widths (Type FZ): Size 2060 with 364 and 365 frame motors, 19.88; Size 2070 with 404 and 405 frame motors, 22.78; Size 2080 with 444 and 445 frame motors, 25.06; Size 2100 with 364 and 445 frame motors, 28.50.

Double, Triple & Quadruple Reduction Dimensions

Type FZ — Sizes 2060 to 2130 / Dimensions—Inch

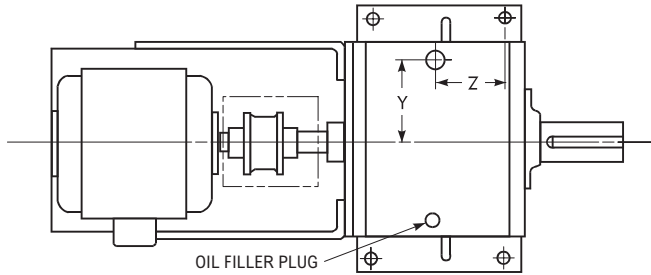

DIMENSIONS ON PAGE 59
(CA IN TABLE BELOW)

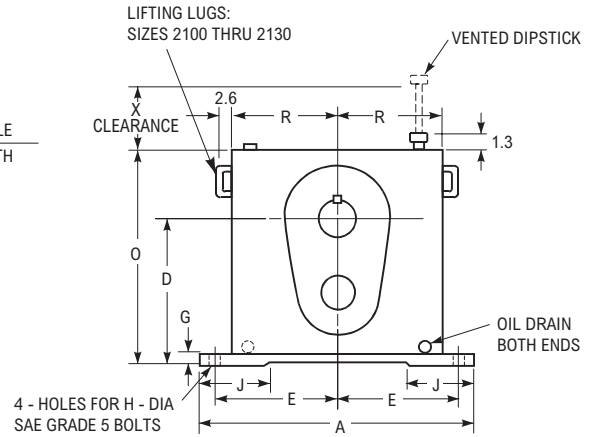
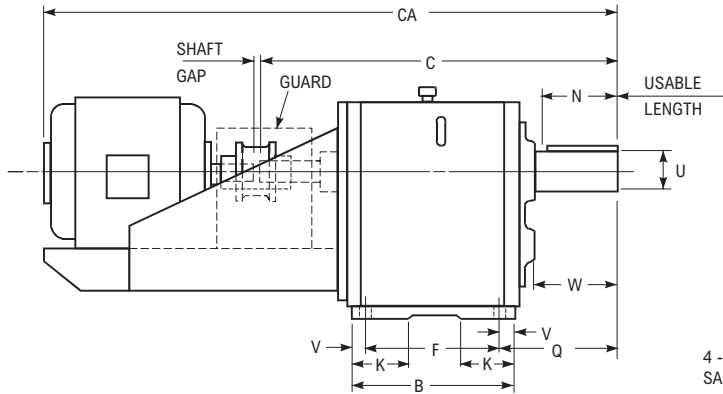

Dimensions (in)

Drive Size	Average Weight of Drive Only (lb) ②	Max. NEMA T & U Frame Size ③ ④	CA – Approximate Overall Length With Motor and Type T Coupling ①																	
			Motor Frame Size ③																	
			143T	145T	182T	184T	213T	215T	254T	256T	284TS	286TS	324TS	326TS	364TS	365TS	404TS	405TS	444TS	445TS
Open Motors																				
2060	370	365	39.2	39.2	39.2	39.2	40.8	42.4	45.5	47.3	49.0	49.0	51.8	51.8	52.4	52.6	–	–	–	–
2070	525	405	42.0	42.0	42.0	42.0	43.2	45.7	49.0	50.7	51.9	52.0	54.7	54.7	55.2	56.0	58.6	59.8	–	–
2080	748	445	44.6	44.6	44.6	44.6	46.7	48.2	52.5	54.1	54.4	55.3	58.0	58.0	58.4	59.8	61.6	62.9	–	–
2090	1016	445	47.6	47.6	47.6	47.6	49.6	51.1	54.4	57.7	57.4	58.7	60.9	61.3	61.8	62.8	64.8	66.3	69.7	71.3
2100	1320	445	50.9	50.9	51.5	51.5	53.0	54.6	57.8	59.5	60.7	62.5	63.5	64.9	66.3	66.6	69.7	69.8	74.7	74.8
2110	1560	445	53.9	53.9	54.5	54.5	55.9	57.5	60.7	62.5	63.7	63.7	66.7	68.2	69.3	69.7	72.7	73.3	77.7	78.4
2120	2210	445	56.6	56.6	56.6	56.6	58.6	61.0	63.9	65.8	66.2	67.0	69.7	69.7	72.3	73.6	75.6	76.8	80.6	81.9
2130	2900	445	–	59.3	59.3	59.3	61.3	62.8	66.6	68.7	68.9	69.7	72.4	72.4	74.9	76.6	78.3	79.7	83.8	85.0
TEFC Motors																				
2060	370	365	36.5	36.9	39.0	40.0	45.2	45.2	50.7	50.7	53.0	53.0	55.8	55.8	57.4	–	–	–	–	–
2070	525	405	38.8	39.3	42.4	43.4	47.3	47.3	53.8	53.8	55.9	55.9	58.7	58.7	60.4	60.3	–	–	–	–
2080	748	445	42.0	42.5	44.6	46.4	50.7	50.7	57.3	57.3	59.0	59.0	62.0	62.0	63.9	63.9	68.2	–	–	–
2090	1016	445	45.1	45.5	47.6	49.4	53.8	53.8	59.3	59.3	61.6	62.2	62.2	65.6	67.2	67.2	71.3	–	–	–
2100	1320	445	–	50.0	51.6	52.6	57.1	57.1	62.6	62.6	65.0	65.0	67.8	67.8	70.6	70.6	74.5	74.5	–	–
2110	1560	445	–	–	54.7	55.7	59.6	59.6	65.7	65.7	67.9	67.9	70.7	70.7	72.3	72.3	78.0	78.0	83.4	–
2120	2210	445	–	–	57.6	58.6	62.6	62.6	68.9	68.9	71.0	71.0	73.8	73.8	75.4	75.4	80.1	80.1	86.7	–
2130	2900	445	–	–	–	61.2	65.2	65.2	70.9	70.9	73.6	73.6	76.3	76.3	78.0	78.0	82.7	82.7	87.6	87.6

- ① CA dimensions are approximate and may vary with motor manufacturer.
- ② Weight shown is for Type FC drive. For Type FZ drive weight, add average drive weight to approximate weight at bottom of page 58.
- ③ Brackets will accept either T, TS, U or US frame motors. Do not exceed the gear drive ratings shown in the selection tables. Standard length and semi-standard length blank bracket dimensions are covered in Engineering 317-315.
- ④ Refer to pages 5 and 6 for instructions when using other than T-frame motors.

Motor Mounts

Type MM — Sizes MM2040 and MM2050 / Dimensions—Inch

Standard Assemblies

Assemblies are viewed from high-speed end of drive. For 3 and 9 o'clock assemblies, refer to ⑤ footnote below to determine dimensions FA, GA, HA and JA. Refer to page 57 for drive dimensions.

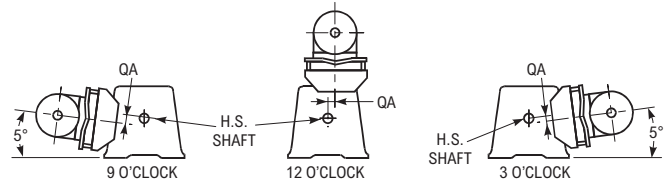

Space-saving Type MM motor mounts are designed for use on UltraMax™ Type FC drives when input through a belt drive is required. The motor mount can be top, left or right side-mounted, and allows for quick belt installation and tensioning.

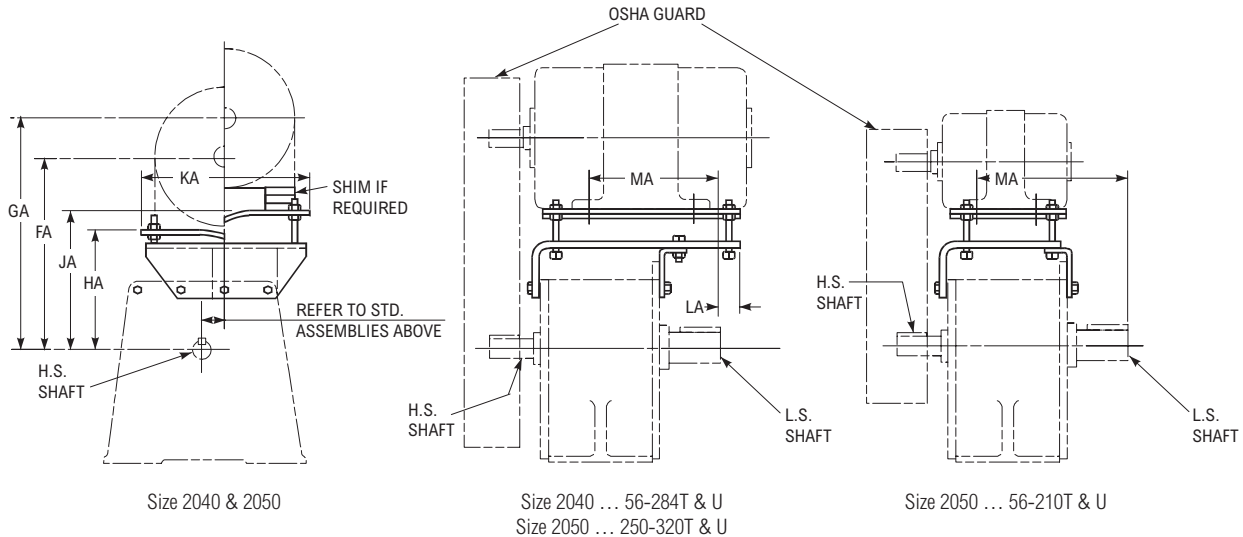

Dimensions (in)

Drive Size ①	Minimum and Maximum Shaft Centers														3 & 9 O'clock FA & GA Addition	HA Min.	JA Max.	PA	Dimension QA Std Assemblies Clock Positions		
	12 O'clock Mounting ②																		3	9	12
	56		140		180		210		250		280		320								
	FA	GA	FA	GA	FA	GA	FA	GA	FA	GA	FA	GA	FA	GA							
MM2040	13.10	16.10	13.10	16.10	14.10	17.10	14.86	17.86	15.86	18.86	16.60	19.60	—	—	1.84	9.60	12.60	8.32	2.00	2.00	0
	—	—	—	—	—	—	—	—	—	—	—	—	—	18.31	21.10	1.84	10.31	13.10	8.32	2.00	2.00
MM2050	14.06	17.00	14.06	17.00	15.06	18.00	15.82	18.76	16.82	19.76	17.56	20.50	18.56	21.50	2.14	10.56	13.50	9.30	2.34	2.34	0

Drive Size ①	56 thru 210			250 thru 284			250 thru 320			320 ③			Dimension MA						
	KA	LA	Motor Mount Wt (lb)	KA	LA	Motor Mount Wt (lb)	KA	LA	Motor Mount Wt (lb)	KA	LA	Motor Mount Wt (lb)	56	140	180	210	250	280	320
MM2040	13.00	-2.28 ④	55	14.00	2.02	70	—	—	—	16.00	5.27	118	12.68	13.18	12.68	11.92	11.16	10.68	10.22
MM2050	15.00	—	60	—	—	—	16.00	2.72	90	—	—	—	15.28	15.78	15.28	14.54	13.78	13.28	12.78

- ① Dimensions are for reference only and are subject to change without notice unless certified.
- ② When determining belt length for minimum shaft centers, follow the belt manufacturer's installation allowance recommendations and also provide for future belt tensioning. Motors may be shimmed up to 1.5".
- ③ Motor mount extends 0.56" below Size 2040 with 320 frame when mounted in 3 and 9 o'clock positions.
- ④ Measure (–) LA to left of shaft end instead of as shown; shaft extends beyond bracket.
- ⑤ To determine shaft centers for 3 & 9 o'clock mountings, add amount shown in the "3 & 9 o'clock Addition" column to the 12 o'clock FA & GA dimensions. Dimensions HA and JA will increase the same amounts.

How to Order

Your nearby Regal Rexnord™ representative or authorized distributor will be pleased to analyze your new or existing application requirements and recommend the most efficient and economical motor mount selections. At the same time, if you wish, his wide experience in the field of power transmission qualifies him to examine your installation and perhaps point out additional ways to increase efficiency and reduce cost with other Regal Rexnord precision products.

The following information is required to make proper selection:

1. Rexnord™ Drive — size and type as shown on nameplate or from selection tables in this catalog.

2. Motor make — horsepower and type.
3. NEMA motor frame size. Check dimension table to make certain motor mount is available for your motor frame size.
4. Required belt centers. If not known, the motor mount will be selected with minimum belt centers (Dimension FA above) based on information from Steps 1 thru 3.
5. Clock position — specify preferred mounting arrangement.

Motor Mounts

Type MM — Sizes MM2060 to MM2130 / Dimensions—Inch

Standard Assemblies

Assemblies are viewed from high speed end of drive. For 3 and 9 o'clock assemblies, refer to ⑤ footnote below to determine dimensions FA, GA, HA and JA. Refer to page 59 for drive dimensions.

NOTE: Motor mounts are not available for drive Sizes 2100 thru 2130 with external backstops or drive Sizes 2060 thru 2130 with shaft fans.

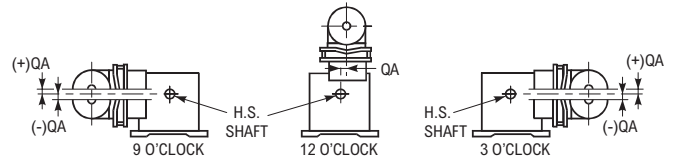

Space-saving Type MM motor mounts are designed for use on UltraMax™ Type FC drives when input through a belt drive is required. The motor mount can be top, left or right side-mounted, and allows for quick belt installation and tensioning.

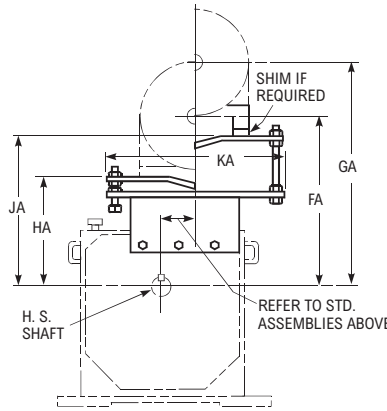

Size 2060 - 2130

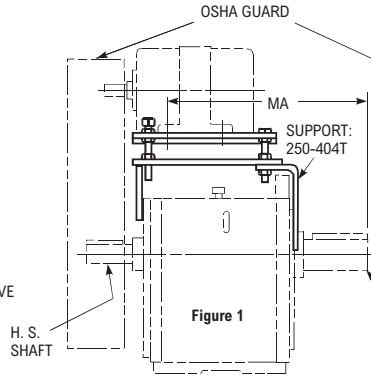

Size 2060-2100 ... 140-210T & U ②
Size 2110-2130 ... 140-400T & U ②

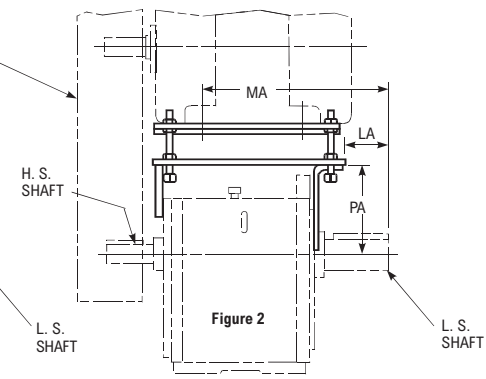

Size 2060-2100 ... 250-400T & U
(Size 2060 Max. U-Frame is 404)

Dimensions (in)

Motor Mount & Drive Size ①	Minimum and Maximum Shaft Centers																3 & 9 O'clock FA & GA Addition ⑤	HA ④ Min	JA ③ Max	PA
	12 O'clock Mounting ③ ⑤																			
	140		180		210		250		280		320		360		400					
FA	GA	FA	GA	FA	GA	FA	GA	FA	GA	FA	GA	FA	GA	FA	GA					
MM2060	16.42	20.02	17.42	21.02	18.18	21.78	19.18	22.78	19.92	23.52	20.92	24.52	22.60	25.52	23.60	26.52	1.96	12.92	16.52	11.48
MM2070	16.92	20.52	17.92	21.52	18.68	22.28	19.68	23.28	20.42	24.02	21.42	25.02	23.10	26.02	24.10	27.02	2.40	13.42	17.02	11.98
MM2080	17.82	21.42	18.82	22.42	19.58	23.18	20.58	24.18	21.32	24.92	22.32	25.92	23.76	26.92	24.76	27.92	2.50	14.32	17.92	12.76
MM2090	18.94	22.54	19.94	23.54	20.70	24.30	21.70	25.30	22.44	26.04	23.44	27.04	24.88	28.04	25.88	29.04	2.32	15.44	19.04	13.88
MM2100	21.32	24.92	22.32	25.92	23.08	26.68	24.08	27.68	24.82	28.42	25.82	29.42	27.26	30.42	28.26	31.42	2.10	17.82	21.42	16.26
MM2110	22.02	25.62	23.02	26.62	23.78	27.38	24.78	28.38	25.52	29.12	26.52	30.12	27.96	31.12	28.96	32.12	2.20	18.52	22.12	16.96
MM2120	21.72	25.32	22.72	26.32	23.48	27.08	24.48	28.08	25.22	28.82	26.22	29.82	27.66	30.82	28.66	31.82	1.90	18.22	21.82	16.66
MM2130	22.62	26.22	23.62	27.22	24.38	27.98	25.38	28.98	26.12	29.72	27.12	30.72	28.56	31.72	29.56	32.72	2.00	19.12	22.72	17.56

Drive Size ①	140 thru 210		250 thru 320			360 thru 400			Dimension MA ⑥ FC2, FC3, FC4							Dimension QA Standard Assemblies Clock Positions			
	KA	Mtr Mt Wt (lb)	KA	LA	Mtr Mt Wt (lb)	KA	LA	Mtr Mt Wt (lb)	140	180	210	250	280	320	360	400	3	9	12
MM2060	15.00	60	16.00	0.08	115	20.00	(+)3.52 ⑦	200	18.74	18.24	17.48	16.74	16.24	15.74	15.36	14.60	(-)0.84 ⑧	(+)1.84 ⑧	2.24 ⑧
MM2070	15.00	60	16.00	2.80 ⑥	115	20.00	(+)0.82 ⑥ ⑦	200	21.46	20.96	20.20	19.46	18.96	18.46	18.06	17.32	(-)2.64 ⑧	(-)1.76 ⑧	2.24 ⑧
MM2080	15.00	75	20.00	1.92 ⑥	170	20.00	1.92 ⑥	220	24.42	23.92	23.16	22.42	21.92	21.42	20.80	20.04	(-)2.44	(-)1.32	3.94
MM2090	15.00	75	20.00	4.94 ⑥	175	20.00	4.94 ⑥	225	27.44	26.94	26.18	25.44	24.94	24.44	23.82	23.06	(-)2.44	(-)1.32	3.94
MM2100	15.00	80	20.00	8.38	195	20.00	8.38	245	30.96	30.46	29.70	28.96	28.46	27.96	27.26	26.50	(-)0.40	(+)0.40	2.76
MM2110	15.00	80	20.00	Use Figure 1	190	20.00	Use Figure 1	240	34.00	33.50	32.74	32.00	31.50	31.00	30.30	29.54	(-)0.40	(+)0.40	2.76
MM2120	15.00	80	20.00	Use Figure 1	190	20.00	Use Figure 1	240	36.88	36.38	35.62	34.88	34.38	33.88	33.18	32.42	(-)2.76	(-)2.76	2.76
MM2130	15.00	80	20.00	Use Figure 1	190	20.00	Use Figure 1	240	39.46	38.96	38.20	37.46	36.96	36.46	35.76	35.00	(-)2.76	(-)2.76	2.76

- ① Dimensions are for reference only and subject to change without notice unless certified.
- ② A support is furnished only for 250T and larger frames.
- ③ When determining belt length for minimum shaft centers, follow the belt manufacturer's installation allowance recommendations and also provide for future belt tensioning. Motors may be shimmed up to 1.5".
- ④ For 360 and 400 frames, add the following to the "HA" dimension: 0.68" for Sizes 2060 and 2070FC; 0.44" for Sizes 2080 thru 2130FC.
- ⑤ To determine shaft centers for 3 & 9 o'clock mountings, add amount shown in the "3 & 9 o'clock Addition" column to the 12 o'clock FA & GA dimensions. Dimensions HA and JA will increase the same amounts.
- ⑥ Sizes 2070, 2110 and 2130FC2: add 0.12" to dimensions MA & LA; Sizes 2080 & 2090FC2: add 0.38" to dimensions MA & LA.
- ⑦ Bracket extends beyond end of shaft; (+)LA is from end of shaft, (right), to end of bracket.
- ⑧ Dimension QA for Sizes 2060 and 2070FC with the 360-400 motor frames are: add 0.46" for 3 o'clock; add 0.34" for 9 o'clock and use 4.34" for 12 o'clock.

Motor Adapters

Type MC / Dimensions—Inch

Type MC motor adapters provide for quick flange mounting of NEMA C-face motors on UltraMax™ Type FC drives.

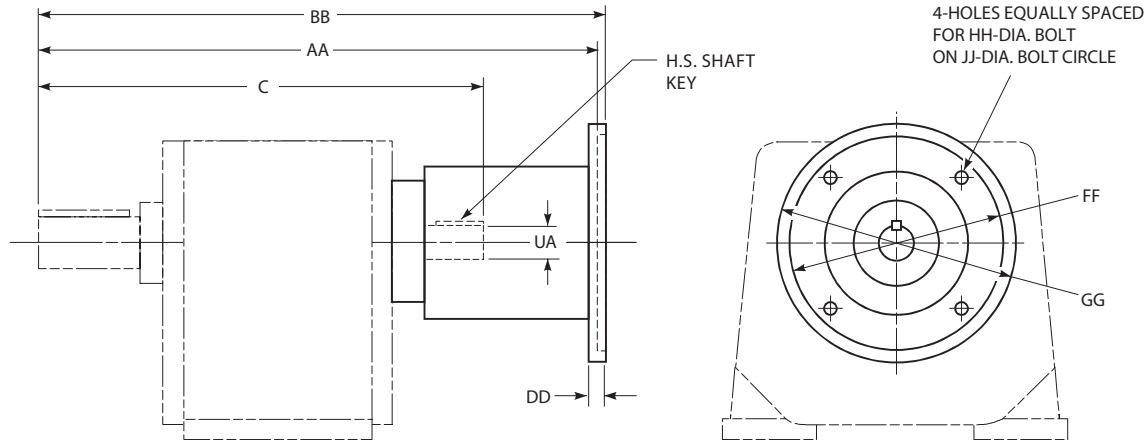

Dimensions (in)

Motor Adapter & Drive Size ①	Drive Type & Reduction	Motor Frame Size	C	AA	BB	DD	FF	GG	HH	JJ	UA	Key	
MC2040	FC2	182-184	18.44	22.61	22.81	0.64	8.502	9.25	0.500	7.250	1.375	0.312 x 0.312 x 2.5	
		213-256	18.44	23.11	23.31	0.64	8.502	9.25	0.500	7.250	1.375	0.312 x 0.312 x 2.5	
		284-286 ③	18.44	23.86	24.06	0.64	10.502	11.50	0.500	9.000	1.375	0.312 x 0.312 x 2.5	
	FC3	56-145	18.44	21.27	21.52	0.64	4.502	7.38	0.375	5.875	1.375	0.312 x 0.312 x 2.5	
		182-184	18.44	22.64	22.84	0.64	8.502	9.25	0.500	7.250	1.375	0.312 x 0.312 x 2.5	
		213-215	18.44	23.14	23.34	0.64	8.502	9.25	0.500	7.250	1.375	0.312 x 0.312 x 2.5	
MC2050	FC2	182-184	21.54	25.81	26.01	0.64	8.502	9.25	0.500	7.250	1.625	0.375 x 0.375 x 3.0	
		213-256	21.54	26.31	26.51	0.64	8.502	9.25	0.500	7.250	1.625	0.375 x 0.375 x 3.0	
		284-286 ③	21.54	27.06	27.26	0.64	10.502	11.50	0.500	9.000	1.625	0.375 x 0.375 x 3.0	
	FC3	56-145	21.54	24.43	24.68	0.64	4.502	7.38	0.375	5.875	1.625	0.375 x 0.375 x 3.0	
		182-184	21.54	25.81	26.01	0.64	8.502	9.25	0.500	7.250	1.625	0.375 x 0.375 x 3.0	
		213-256	21.54	26.31	26.51	0.64	8.502	9.25	0.500	7.250	1.625	0.375 x 0.375 x 3.0	
	FC4	56-145	19.98	23.56	23.81	0.64	4.502	7.38	0.375	5.875	1.000	0.250 x 0.250 x 1.5	
		182-184	19.98	24.94	25.14	0.64	8.502	9.25	0.500	7.250	1.000	0.250 x 0.250 x 1.5	
		213-215	24.94	29.26	29.46	0.64	8.502	9.25	0.500	7.250	1.875	0.500 x 0.500 x 3.2	
MC2060	FC2	254-256	24.94	29.76	29.96	0.64	8.502	9.25	0.500	7.250	1.875	0.500 x 0.500 x 3.2	
		284-286 ③	24.94	30.51	30.71	0.64	10.502	11.50	0.500	9.000	1.875	0.500 x 0.500 x 3.2	
	FC3	143-145	24.32	27.48	27.73	0.64	4.502	7.38	0.375	5.875	1.500	0.375 x 0.375 x 3.0	
		182-184	24.32	28.85	29.05	0.64	8.502	9.25	0.500	7.250	1.500	0.375 x 0.375 x 3.0	
		213-256	24.32	29.35	29.55	0.64	8.502	9.25	0.500	7.250	1.500	0.375 x 0.375 x 3.0	
	FC4	56-145	23.56	27.48	27.73	0.64	4.502	7.38	0.375	5.875	1.250	0.250 x 0.250 x 2.2	
		182-184	23.56	28.73	28.93	0.64	8.502	9.25	0.500	7.250	1.250	0.250 x 0.250 x 2.2	
	MC2070	FC3	182-184	27.28	31.52	31.72	0.64	8.502	9.25	0.500	7.250	1.750	0.375 x 0.375 x 3.0
			213-256	27.28	32.02	32.22	0.64	8.502	9.25	0.500	7.250	1.750	0.375 x 0.375 x 3.0
284-286 ③			27.28	32.77	32.97	0.64	10.502	11.50	0.500	9.000	1.750	0.375 x 0.375 x 3.0	
FC4		56-145	26.54	30.07	30.32	0.64	4.502	7.38	0.375	5.875	1.375	0.312 x 0.312 x 2.5	
		182-215	26.54	31.45	31.65	0.64	8.502	9.25	0.500	7.250	1.375	0.312 x 0.312 x 2.5	
		213-215	26.54	31.45	31.65	0.64	8.502	9.25	0.500	7.250	1.375	0.312 x 0.312 x 2.5	
MC2080	FC3	182-215 ②	30.64	34.96	35.16	0.64	8.502	9.25	0.500	7.250	2.000	0.500 x 0.500 x 3.5	
		254-256 ②	30.64	35.46	35.66	0.64	8.502	9.25	0.500	7.250	2.000	0.500 x 0.500 x 3.5	
		284-286 ③	30.64	36.21	36.41	0.64	10.502	11.50	0.500	9.000	2.000	0.500 x 0.500 x 3.5	
	FC4	56-145	29.90	32.80	33.05	0.64	4.502	7.38	0.375	5.875	1.625	0.375 x 0.375 x 3.0	
		182-184	29.90	34.18	34.38	0.64	8.502	9.25	0.500	7.250	1.625	0.375 x 0.375 x 3.0	
		213-215	29.90	34.68	34.88	0.64	8.502	9.25	0.500	7.250	1.625	0.375 x 0.375 x 3.0	

① Dimensions are for reference only and are subject to change without notice unless certified.

② Motor frames 182-256 will have conduit box mounted at 45° for drive Size 2080F3 only.

③ Adapter for motor frames 284-286 uses an 8-hole pattern.

Motor Plates

Type MP / Dimensions—Inch

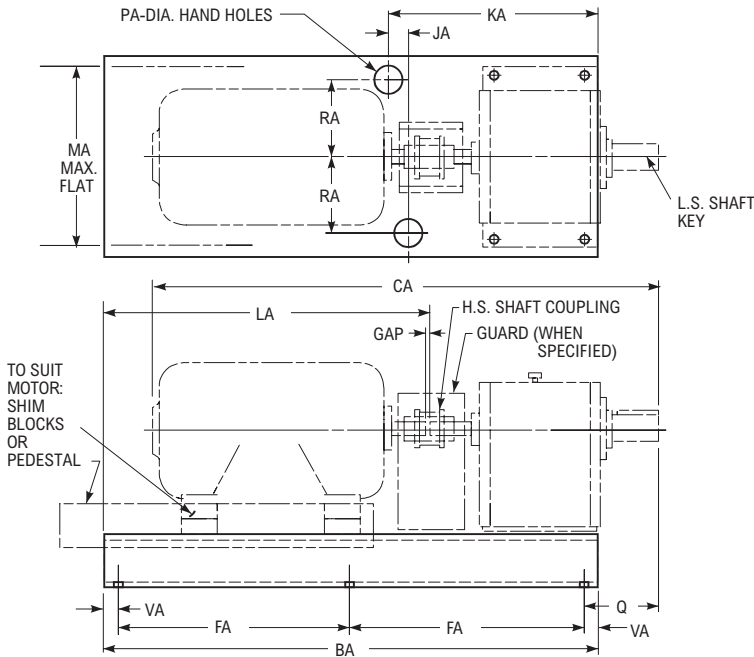

Type MP motor plates are used to accommodate oversize motors, special couplings, clutches or brakes. Motor plates allow for simplified installation of the total assembly, and also provide a rigid, "hard" mounting of the UltraMax and motor when required.

Hand holes provide access to the drive, motor and motor plate foundation bolts; they also provide simplified handling and venting when the motor plate is grouted in place.

Standard motor plates are available; each plate accommodating two drive sizes, for example, MP40/50 is for size 2040/2050 drives.

Special motor plates can be designed to accommodate special couplings, clutches, brakes and prime movers which will not fit on the standard motor plates shown here.

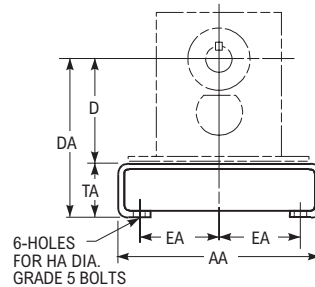

Dimensions (in)

Drive Size ①	Motor Plate (MP) Size	D	DA ±.14	LA			Q
				F2	F3	F4	
2040	MP40/50	8.50	14.50	33.52	33.52	NA	7.46
2050	MP40/50	9.60	15.60	31.62	31.62	33.18	8.66
2060	MP60/70-2	10.60	16.60	22.06	22.68	23.44	8.50
	MP60/70	10.60	16.60	40.06	40.68	41.44	8.50
2070	MP60/70-2	11.66	17.66	19.66	20.72	21.46	9.50
	MP60/70	11.66	17.66	37.66	38.72	39.46	9.50
2080	MP80/90-2	12.78	21.78	37.02	38.06	38.80	11.20
	MP80/90	12.78	21.78	52.02	53.06	53.80	11.20
2090	MP80/90-2	15.74	24.74	34.82	36.24	36.98	12.40
	MP80/90	15.74	24.74	49.82	51.24	51.98	12.40

Drive Size ①	Motor Plate (MP) Size	D	DA ±.14	LA — W/O Backstop			LA — W/Backstop			Q
				FC2	FC3	FC4	FC2	FC3	FC4	
2100	100/110-2	17.40	26.40	32.54	33.90	34.38	25.94	28.30	28.78	13.54
	100/110	17.40	26.40	58.54	59.90	60.38	51.94	54.30	54.78	13.54
2110	100/110-2	19.50	28.50	29.60	31.52	32.00	23.00	25.92	26.40	14.12
	100/110	19.50	28.50	55.60	57.52	58.00	49.00	51.90	52.40	14.12
2120	120/130-4	21.90	30.90	26.80	28.78	29.56	20.20	23.32	23.58	14.68
	120/130-2	21.90	30.90	46.80	48.78	49.56	40.20	43.32	43.58	14.68
2130	120/130	21.90	30.90	74.80	76.78	77.56	68.20	71.32	71.58	14.68
	120/130-4	24.70	33.70	24.68	27.28	28.06	18.08	21.82	22.08	15.76
2130	120/130-2	24.70	33.70	44.68	47.28	48.06	38.08	41.82	42.08	15.76
	120/130	24.70	33.70	72.68	75.28	76.06	66.08	69.82	70.08	15.76

Drive Size ①	Motor Plate (MP) Size	AA ②	BA	EA	FA	GA	HA	JA	KA	MA	PA	RA	TA +.20 -.00	VA	Wt (lb) (w/o drive)
2040/2050	MP40/50	20.00	46.00	7.50	21.50	0.50	1.000	0	15.50	18.00	5.00	6.70	5.90	1.50	270
2060/2070	MP60/70-2	25.00	40.00	10.00	18.50	0.50	1.000	0	20.00	23.00	6.00	8.00	5.90	1.50	272
	MP60/70	25.00	58.00	10.00	27.50	0.50	1.000	1.00	22.00	23.00	6.00	8.00	5.90	1.50	380
2080/2090	MP80/90-2	30.00	60.00	11.80	27.50	0.75	1.500	0	23.30	26.50	6.00	9.00	8.90	2.50	874
	MP80/90	30.00	75.00	11.80	35.00	0.75	1.500	1.00	31.00	26.50	6.00	9.00	8.90	2.50	980
2100/2110	MP100/110-2	35.00	60.00	14.20	27.50	0.75	1.500	0	30.00	31.50	6.00	12.00	8.90	2.50	942
	MP100/110	35.00	86.00	14.20	40.50	0.75	1.500	2.00	36.00	31.50	6.00	12.00	8.90	2.50	1150
2120/2130	MP120/130-4	39.00	60.00	16.20	27.50	0.75	1.500	0	30.00	35.50	6.00	14.00	8.90	2.50	1008
	MP120/130-2	39.00	80.00	16.20	37.50	0.75	1.500	0	38.24	35.50	6.00	14.24	8.90	2.50	1294
	MP120/130	39.00	108.00	16.20	51.50	0.75	1.500	4.00	46.00	35.50	6.00	14.00	8.90	2.50	1610

① Dimensions are for reference only and are subject to change without notice unless certified.

② When a motor pedestal is furnished, dimension AA is 1.24" wider for MP 40/50, 1.50" wider for MP60 thru 90 and 1.00" wider for MP100 thru 130.

Slide Rails

Type SR / Dimensions-Inch

Type SR slide rails can be used in conjunction with UltraMax™ MP motor plates for positioning of the drive assembly, and to facilitate chain and belt drive installation, tensioning and service.

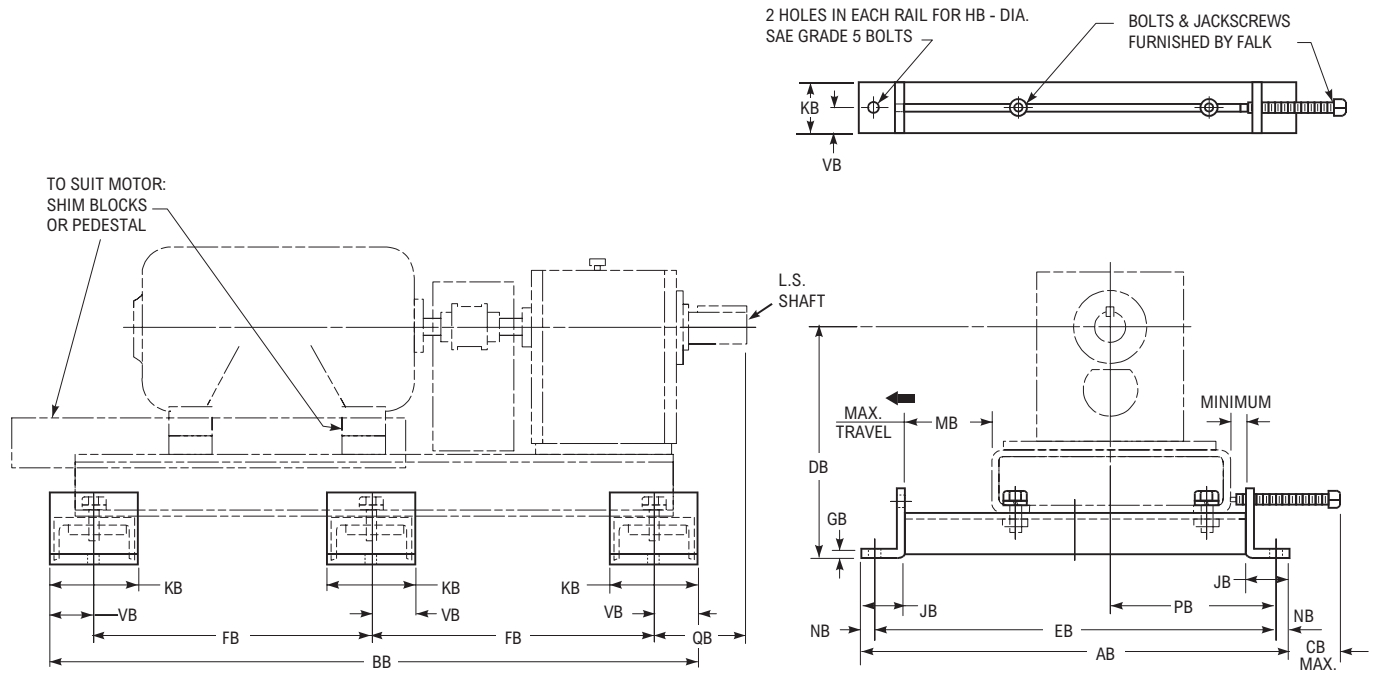

Dimensions (in)

Slide Rail & Drive Size ①	Motor Plate (MP) Size	AB	BB	CB Max	DB	EB	FB	GB	HB	JB	KB	MB	NB	PB Min	QB	VB
SR2040	MP40/50	40.00	50.00	4.20	18.26	37.40	21.50	0.75	1.00	4.00	7.00	6.44	1.30	13.00	7.46	3.50
SR2050	MP40/50	40.00	50.00	4.20	19.36	37.40	21.50	0.75	1.00	4.00	7.00	6.44	1.30	13.00	8.66	3.50
SR2060	MP60/70-2	40.00	44.00	4.20	20.36	37.40	18.50	0.75	1.00	4.00	7.00	6.44	1.30	15.50	8.50	3.50
	MP60/70	40.00	62.00	4.20	20.36	37.40	27.50	0.75	1.00	4.00	7.00	6.44	1.30	15.50	8.50	3.50
SR2070	MP60/70-2	40.00	44.00	4.20	21.42	37.40	18.50	0.75	1.00	4.00	7.00	6.44	1.30	15.50	9.50	3.50
	MP60/70	40.00	62.00	4.20	21.42	37.40	27.50	0.75	1.00	4.00	7.00	6.44	1.30	15.50	9.50	3.50
SR2080	MP80/90-2	60.00	64.60	3.38	27.04	56.00	27.50	1.00	1.50	6.00	9.60	7.20	2.00	19.30	11.20	4.80
	MP80/90	60.00	79.60	3.38	27.04	56.00	35.00	1.00	1.50	6.00	9.60	7.20	2.00	19.30	11.20	4.80
SR2090	MP80/90-2	60.00	64.60	3.38	30.00	56.00	27.50	1.00	1.50	6.00	9.60	7.20	2.00	19.30	12.40	4.80
	MP80/90	60.00	79.60	3.38	30.00	56.00	35.00	1.00	1.50	6.00	9.60	7.20	2.00	19.30	12.40	4.80
SR2100	MP100/110-2	60.00	64.60	3.38	31.66	56.00	27.50	1.00	1.50	6.00	9.60	7.20	2.00	21.80	13.54	4.80
	MP100/110	60.00	90.60	3.38	31.66	56.00	40.50	1.00	1.50	6.00	9.60	7.20	2.00	21.80	13.54	4.80
SR2110	MP100/110-2	60.00	64.60	3.38	33.76	56.00	27.50	1.00	1.50	6.00	9.60	7.20	2.00	21.80	14.12	4.80
	MP100/110	60.00	90.60	3.38	33.76	56.00	40.50	1.00	1.50	6.00	9.60	7.20	2.00	21.80	14.12	4.80
SR2120	MP120/130-4	60.00	64.60	3.38	36.16	56.00	27.50	1.00	1.50	6.00	9.60	7.20	2.00	23.80	14.68	4.80
	MP120/130-2	60.00	84.60	3.38	36.16	56.00	37.50	1.00	1.50	6.00	9.60	7.20	2.00	23.80	14.68	4.80
	MP120/130	60.00	112.60	3.38	36.16	56.00	51.50	1.00	1.50	6.00	9.60	7.20	2.00	23.80	14.68	4.80
SR2130	MP120/130-4	60.00	64.60	3.38	38.96	56.00	27.50	1.00	1.50	6.00	9.60	7.20	2.00	23.80	15.76	4.80
	MP120/130-2	60.00	84.60	3.38	38.96	56.00	37.50	1.00	1.50	6.00	9.60	7.20	2.00	23.80	15.76	4.80
	MP120/130	60.00	112.60	3.38	38.96	56.00	51.50	1.00	1.50	6.00	9.60	7.20	2.00	23.80	15.76	4.80

① Dimensions are for reference only and are subject to change without notice unless certified.

Slide Bases

Type SB / Dimensions—Inch

Type SB slide bases provide for convenient positioning of UltraMax™ drives, and facilitate chain and belt installation tensioning and service. The slide base is permanently bolted to the foundation, and when a change of position is desired, the drive is easily shifted by loosening the gear drive foundation bolts and turning the adjusting screws. After the desired belt or chain tension is obtained, the drive foundation bolts are tightened, and the machine is ready for operation. All drives on slide bases are available with motor mounts in the 12 o'clock position; Sizes 2090 and larger are also available with motor mounts in the 3 and 9 o'clock positions.

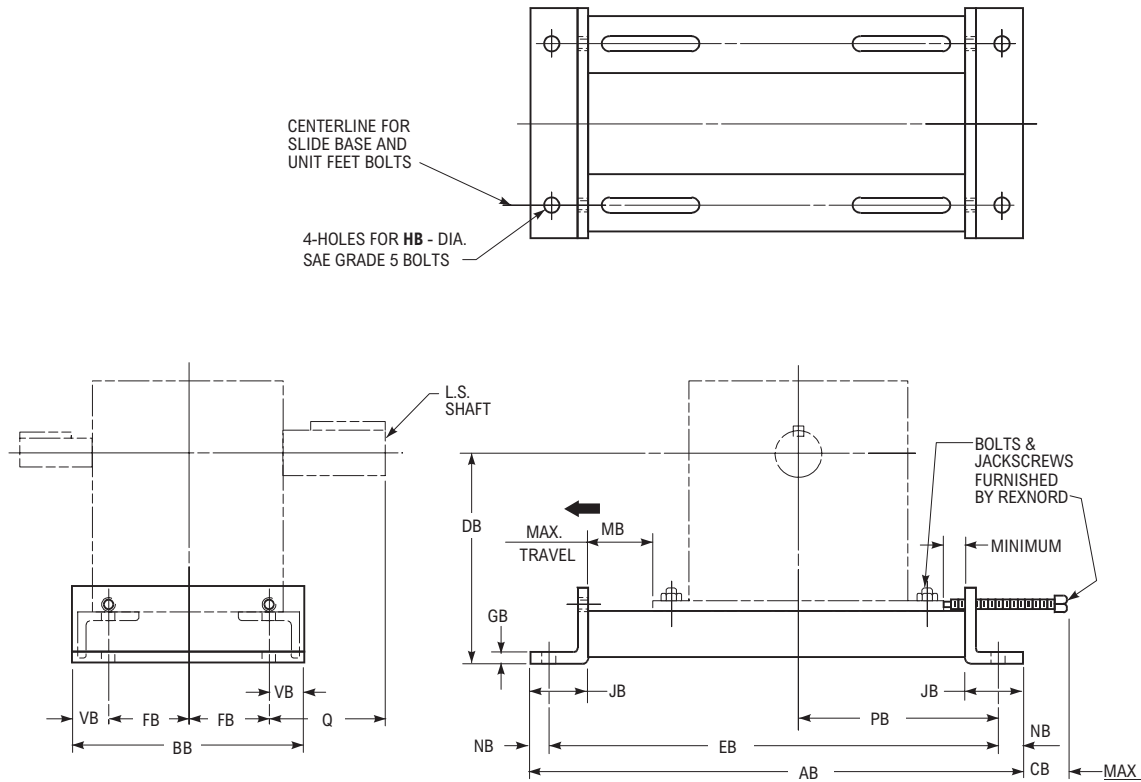

Dimensions (in)

Slide Base & Drive Size ①	Q	AB	BB	CB Max	DB	EB	FB	GB	HB	JB	MB	NB	PB Min	VB	Wt (lb) Approx.
SB2040	6.86	25.02	10.20	3.36	10.76	23.22	3.05	0.50	0.750	2.50	4.10	0.90	9.54	2.05	41
SB2050	8.10	28.30	11.60	3.56	12.36	26.30	3.55	0.50	0.875	3.00	4.70	1.00	10.80	2.25	62
SB2060	8.00	31.32	14.70	2.78	13.86	28.72	5.00	0.62	1.000	3.50	4.70	1.30	12.00	2.35	92
SB2070	9.20	33.72	16.40	2.90	14.92	31.12	5.65	0.62	1.125	3.50	4.70	1.30	13.20	2.55	104
SB2080	10.00	37.68	19.00	4.18	16.54	34.88	6.60	0.75	1.250	4.00	5.70	1.40	14.58	2.90	169
SB2090	11.50	44.72	21.00	2.18	20.00	39.72	7.15	1.00	1.500	6.00	5.70	2.50	17.00	3.35	228
SB2100	13.14	46.16	21.20	2.26	21.66	41.16	7.48	1.00	1.500	6.00	5.70	2.50	17.72	3.12	264
SB2110	13.72	49.10	23.60	3.22	25.76	44.10	8.64	1.00	1.500	6.00	6.76	2.50	18.66	3.16	344
SB2120	14.58	52.12	25.60	3.24	28.16	47.12	9.40	1.00	1.750	6.00	6.76	2.50	20.18	3.40	382
SB2130	16.16	53.64	26.20	3.24	30.96	48.64	9.65	1.00	1.750	6.00	6.76	2.50	20.94	3.45	394

① Dimensions are for reference only and are subject to change without notice unless certified. All drives on slide bases are available with motor mounts in the 12 o'clock position; Sizes 2090 and larger are also available with motor mounts in the 3 and 9 o'clock positions.

Backstops

Type IBS & EBS / Dimensions—Inch

Prevent Reverse Rotation

Backstops provide positive prevention of reverse rotation or backrun without backlash on conveyors, elevator head shafts and similar applications. Designed as standard accessories, backstops can be furnished on all horizontal concentric shaft drives.

To prevent damage to backstops due to incorrect motor shaft rotation at start-up, couplings are NOT assembled when drives are furnished with backstops. After completing the electrical connection, check motor and driveshaft rotations. Then complete alignment and assembly of coupling.

DO NOT use a backstop as a substitute for a brake.

Both types of backstops (internal or external) are designed to prevent reverse rotation 5 times or less in eight hours, with one minute or more in the over-running direction between backstopping load applications. If backstopping operations are more frequent, or the time between operations is less than one minute, the backstop is classified as a working or indexing device and the application must be referred to the Factory for selection. When ordering, specify low-speed shaft rotation when viewing drive from the end of the low-speed shaft.

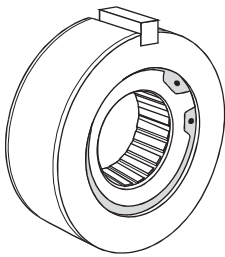

Internal (IBS) cartridge type

Drive Sizes 2040 thru 2090

Internal backstop, cartridge type, compact, reliable and no measurable power loss. Can be added, removed or reversed without disturbing revolving elements. Mounted internally on the outer end of the low-speed pinion shaft, backstop load transmitted only through low speed gear set. Positive continuous lubrication, 50% or more of backstop is immersed in oil. Drive dimensions with and without backstops are identical except for dimension W shown on dimension pages. Backstops are NOT available for drive Sizes 2040-2090 with 1.5 thru 4.57:1 ratios.

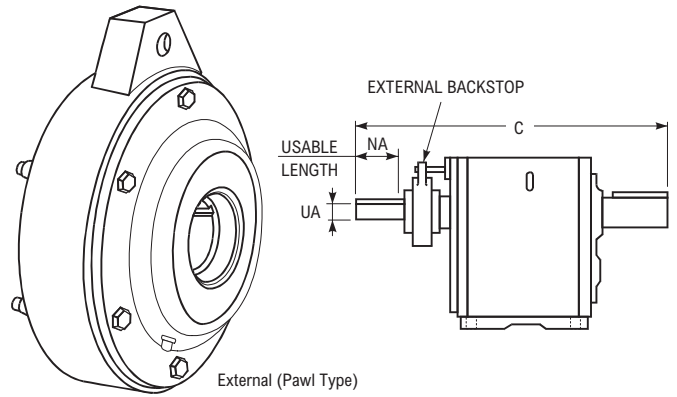

External (Pawl Type)

Drive Sizes 2100 thru 2130

DO NOT use Falk™ External Backstops (Pawl Type) in tandem. Refer to Factory all applications involving the need for two or more backstops in one system. The Falk Pawl type backstop is designed to operate during overrunning within a speed range of 400 to 1800 rpm. Contact Factory for creep drive applications and for continuous speeds less than 400 rpm, or greater than 1800 rpm. Refer to Factory for tilt limits of backstops.

TYPE FC — External Pawl type backstop is mounted on extended high-speed shaft. Refer to backstop selection table on page 69 for all backstop selections.

TYPE FZ — External Pawl type backstop is mounted on extended high-speed shaft. Motor brackets for drives with external backstops may be slightly longer and are furnished blank (not drilled). Refer to price list for information required by Regal Rexnord™ to drill and/or mount motor. Falk self-contained backstop, precision manufactured for either direction of rotation. Backstop housing, case-hardened on the inner periphery, precision ground. Pawls pivot about hardened steel pins in forged rotor hub. Bearings are pre-lubricated and sealed (or shielded) and require no future lubrication. Grease-purged seals are standard on Pawl Type. Drive dimensions with and without external backstops are identical except for the high-speed shaft extension.

Drive Size ①	Double Reduction — FC2/FZ2					Triple Reduction — FC3/FZ3				Quadruple Reduction — FC4/FZ4			
	C	Ratio Range	NA	High-Speed Shaft ②		C	NA	High-Speed Shaft ②		C	NA	High-Speed Shaft ②	
				UA	Key			UA	Key			UA	Key
2100	45.10	5.06-13.95	5.24	2.7500	0.625 x 0.625 x 11.00	42.74	3.88	2.1250	0.500 x 0.500 x 9.00	42.26	3.38	1.8750	0.500 x 0.500 x 8.00
		17.09-31.39	6.22	2.1250	0.500 x 0.500 x 11.00								
2110	48.62	7.59-20.93	5.62	3.0000	0.750 x 0.750 x 11.50	45.70	3.82	2.1250	0.500 x 0.500 x 9.00	45.22	3.32	1.8750	0.500 x 0.500 x 8.00
		25.63-31.39	6.62	2.1250	0.500 x 0.500 x 11.50								
2120	51.98	11.39-31.39	6.22	3.2500	0.750 x 0.750 x 12.00	48.86	4.00	2.1250	0.500 x 0.500 x 9.00	48.60	3.74	2.0000	0.500 x 0.500 x 8.00
2130	55.18	13.95-31.39	6.76	3.5000	0.875 x 0.875 x 12.50	51.44	4.00	2.1250	0.500 x 0.500 x 9.00	51.18	3.76	2.0000	0.500 x 0.500 x 8.00

① Dimensions are for reference only and are subject to change without notice unless certified.

② Shaft diameters under 3" are held to limits of +.0000", -.0005". Shaft diameters 3" and over are held to limits of +.000", -.001". Shaft keyseat depth is one-half of key height. Key extends from the end of the shaft through the backstop.

Backstops

External (Pawl Type) Backstop Selection/580 RPM or Higher

Type EBS

Nominal Ratios		Drive Size				Nominal Ratios
		2100	2110	2120	2130	
Double Reduction	5.06					5.06
	6.20				① Drive rating exceeds backstop rating. Refer to Regal Rexnord™.	6.20
	7.59					7.59
	9.30					9.30
	11.39					11.39
	13.95				#60 Backstop	13.95
	17.09					17.09
	20.93				#20 Backstop	20.93
	25.63					25.63
	31.39					31.39
Triple Reduction	38.44				#20 Backstop	38.44
	47.08					47.08
	57.66					57.66
	70.62					70.62
	86.50					86.50
	105.90					105.90
	129.70					129.70
	158.90					158.90
	194.60					194.60
Quadruple Reduction	238.40				#20 Backstop	238.40
	291.90					291.90
	357.50					357.50
	437.90					437.90
	536.30					536.30
	656.80					656.80
	804.50					804.50
	985.30					985.30

① Gear drive maximum rating at 580 RPM exceeds #60 B1F rating. #60 backstop may be used only if required high-speed shaft torque is less than 40,320 lb-in.

Electric Fans

Type EF / Dimensions–Inch

Electric fans achieve thermal capacities up to twice that of shaft fans, are unaffected by shaft rotation and speeds, and are thermostatically controlled to shut off when not required. Electric fans can be mounted on either side of the UltraMax and permit full use of the UltraMax usable shaft extensions. Electric fans are available with the following motor packages:

- 60 Hz, 3 Phase, 220/380 VAC
- 60 Hz, 3 Phase, 265/460 VAC
- 50 Hz, 3 Phase, 220/380 VAC

Other motor package options may be available. Consult Factory for selection, price and delivery.

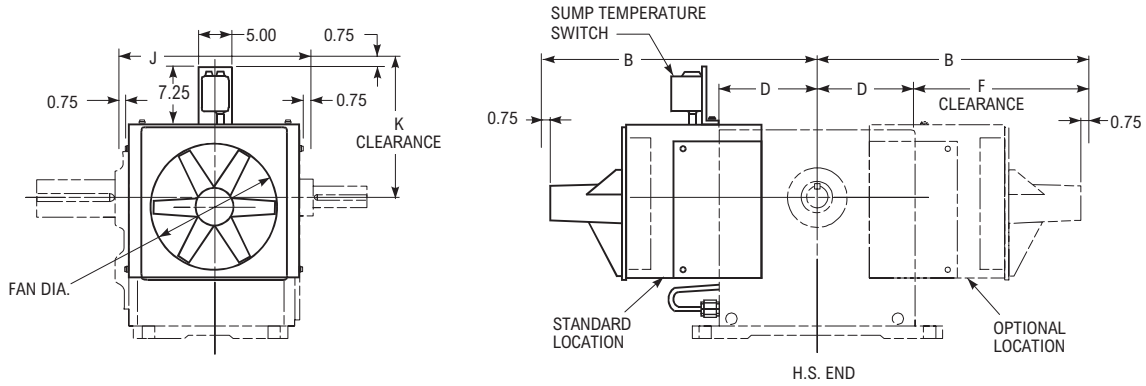

Dimensions (in)

Electric, Drive Size & Reduction ①	Electric Fan Dia	B	D	F	J	K
EF2060 FC2/3 & FZ2/3	12	24.63	6.9	17.73	17.05	14.30
EF2070 FC2/3 & FZ2/3	12	25.59	7.9	17.69	19.05	14.87
EF2080 FC2/3 & FZ2/3	12	26.33	8.7	17.63	21.42	15.37
EF2090 FC2/3 & FZ2/3	14	28.21	9.6	18.61	23.30	16.53
EF2100 FC2/3 & FZ2/3	16	30.15	10.7	19.45	25.05	17.20
EF2110 FC2/3 & FZ2/3	18	32.01	11.6	20.41	27.67	18.40
EF2120 FC2/3 & FZ2/3	20	34.12	12.6	21.52	30.05	19.78
EF2130 FC2/3 & FZ2/3	22	37.93	13.5	24.43	31.55	20.66

① Dimensions are for reference only and are subject to change without notice unless certified. Drawings are representative of this series of drives and may not agree in exact detail for all drive sizes.

Cooling Tubes

Type CT / Dimensions-Inch

Cooling tubes are an economical alternative to pumps and coolers for thermal requirements beyond the range of fans. Water is circulated through a series of finned tubes in the sump of the drive. All joints and connections are external, eliminating any chance of leakage into the drive.

A minimum flow rate of 2 gallons per minute of clean water is required to prevent tube fouling. The maximum flow rate to prevent tube erosion is 5 gallons per minute. Thermal power ratings are based on a water inlet temperature of 70°F (21°C) with 2 gallons per minute flow rate.

WATER INLET & OUTLET CONNECTIONS (All Sizes & Reductions)

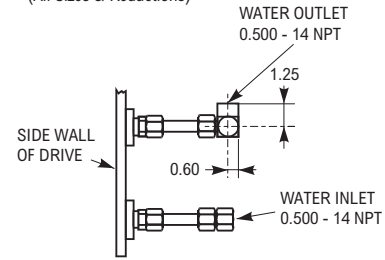

Provide Clearance for Water Connections

DRIVE SIZES 2060F, 2070F, & 2080F ALL REDUCTIONS & RATIOS (1.50 - 985:1) ①
DRIVE SIZES 2090F2 - RATIOS (1.50 - 4.57:1 ONLY)

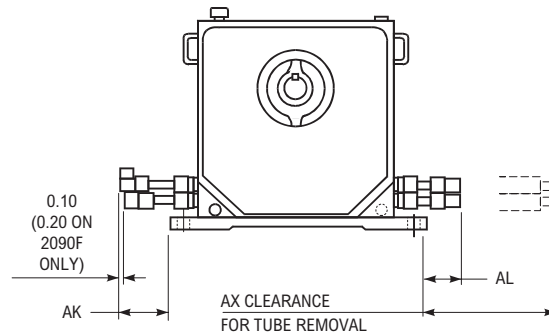
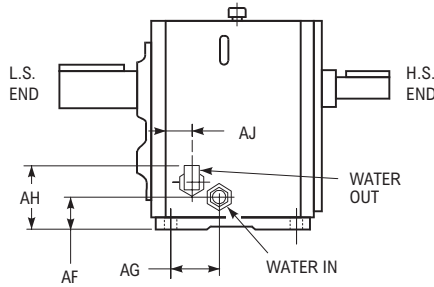

DRIVE SIZES 2090F2, F3, & F4 RATIOS (5.06 - 985:1) ①
DRIVE SIZES 2100-2130F ALL REDUCTIONS & RATIOS (1.50 - 985:1)

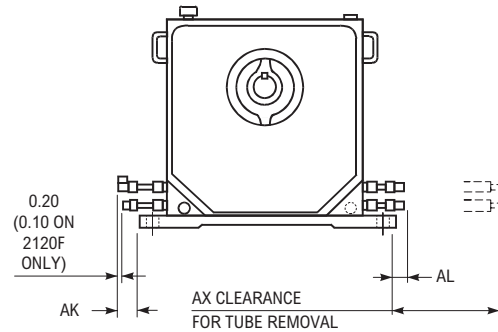
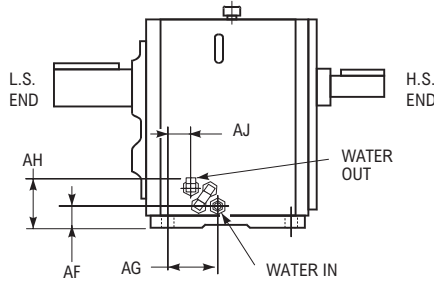

Dimensions (in)

Cooling Tube & Drive Size ①	Drive Reduction	AF	AG	AH	AJ	AK	AL	AX	Std Number of Tubes
CT2060	FC/FZ 2, 3 & 4	2.16	3.80	4.56	1.80	2.7	2.8	19.0	2
CT2070	FC/FZ 2, 3 & 4	2.16	4.35	3.81	2.08	2.6	2.8	21.2	2
CT2080	FC/FZ 2, 3 & 4	2.30	5.40	3.81	2.39	2.4	2.6	22.4	2
CT2090	FC/FZ 2, 3 & 4	2.59	5.60	6.13	2.32	1.7	1.8	23.3	4
CT2090	FC/FZ 2 ②	2.59	5.60	4.10	2.59	1.7	1.8	23.3	2
CT2100	FC/FZ 2, 3 & 4	2.75	6.11	6.29	2.83	1.6	1.7	25.0	4
CT2110	FC/FZ 2, 3 & 4	2.75	6.50	6.29	3.22	2.0	2.1	27.4	4
CT2120	FC/FZ 2, 3 & 4	2.99	8.52	6.74	2.94	1.4	1.6	28.9	6
CT2130	FC/FZ 2, 3 & 4	2.99	8.19	8.83	6.23	1.4	1.5	30.5	8

① Dimensions are for reference only and are subject to change without notice unless certified. Drawings are representative of this series of drives and may not agree in exact detail for all drive sizes.

② Ratios 1.50 thru 4.57 only.

Reliability Package

Type FC & FZ Double, Triple & Quadruple Reduction — Sizes 2040 to 2050 / Dimensions—Inch

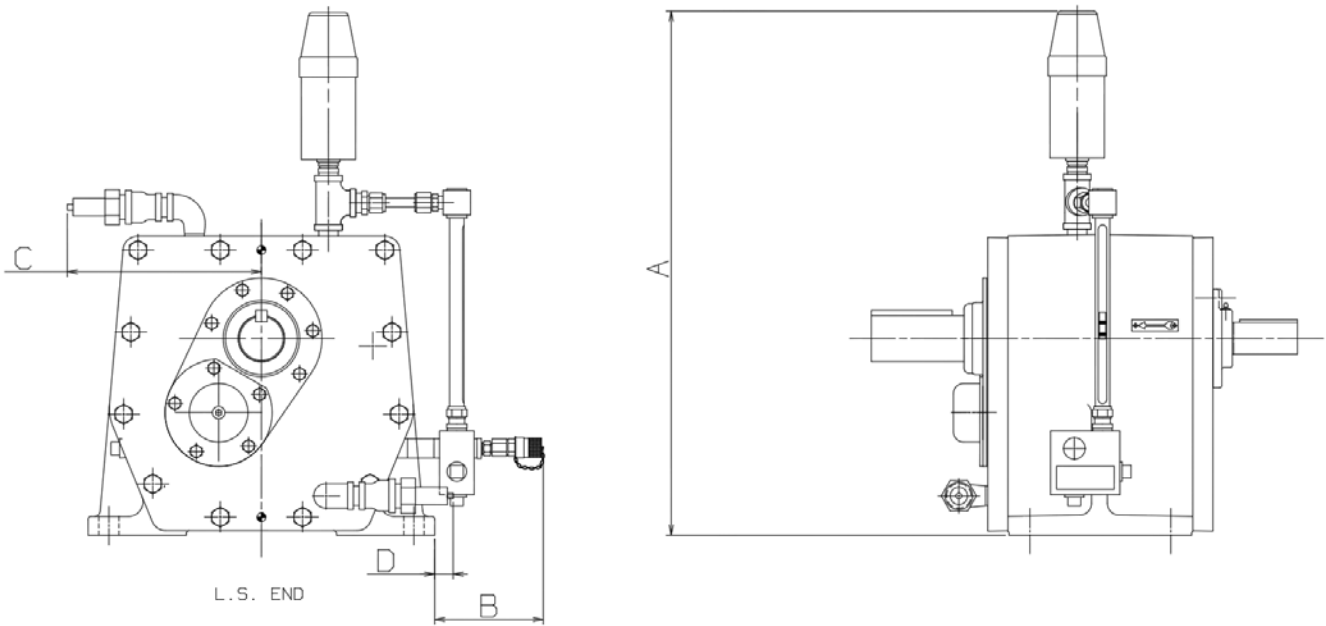

Dimensions (in)

Drive Size	A	B	C	D
2040	22.64	4.70	8.40	0.80
2050	24.30	5.10	8.90	0.35

Reliability Package

Type FC & FZ Double, Triple & Quadruple Reduction — Sizes 2060 to 2130 / Dimensions—Inch

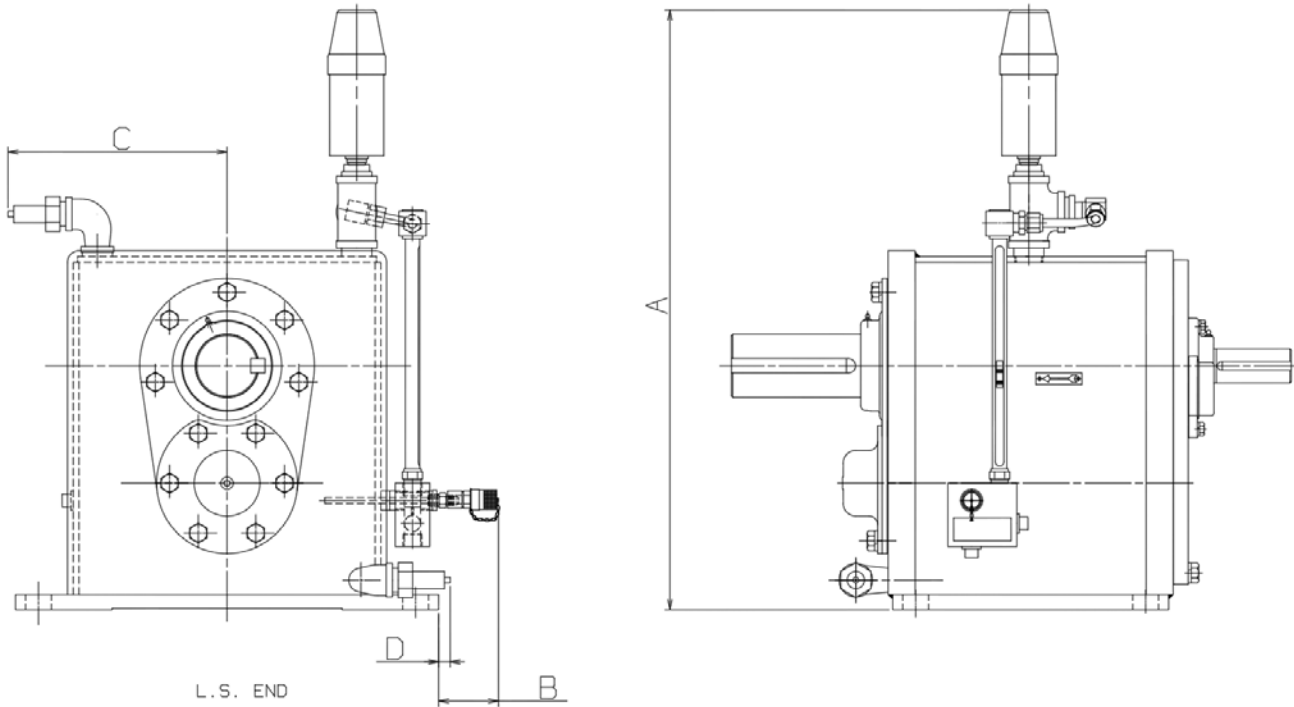

Dimensions (in)

Drive Size	A	B	C	D
2060	26.23	2.34	9.36	0.23
2070	27.77	2.30	10.49	0.18
2080	31.16	1.97	10.73	N/A ①
2090	35.27	1.36	12.03	N/A ①
2100	38.00	2.03	12.95	N/A ①
2110	40.80	1.97	13.76	N/A ①
2120	45.86	1.49	14.51	N/A ①
2130	49.56	1.61	15.39	N/A ①

① Dimension D is Not Applicable because the quick disconnect outlet does not protrude from the foot of the unit.

Coupling Guards

Falk™ UltraMax™ standard low-speed coupling guards provide quick delivery at a low price. In stock at Regal Rexnord, each guard is designed for a specific size UltraMax, and can be adjusted to suit a number of standard couplings and driven equipment requirements. The guards are 14 gauge steel, painted with Regal Rexnord™ standard paint. Safety Yellow paint can be provided at additional cost with extended delivery.

Regal Rexnord has designed the UltraMax end of the guard for close mounting, minimal clearance and maximum guarding. The buyer assumes full responsibility for proper guarding of the driven machine end to applicable national and local standards.

For special, made-to-order guards, provide complete details to your Regal Rexnord district office for a quotation.

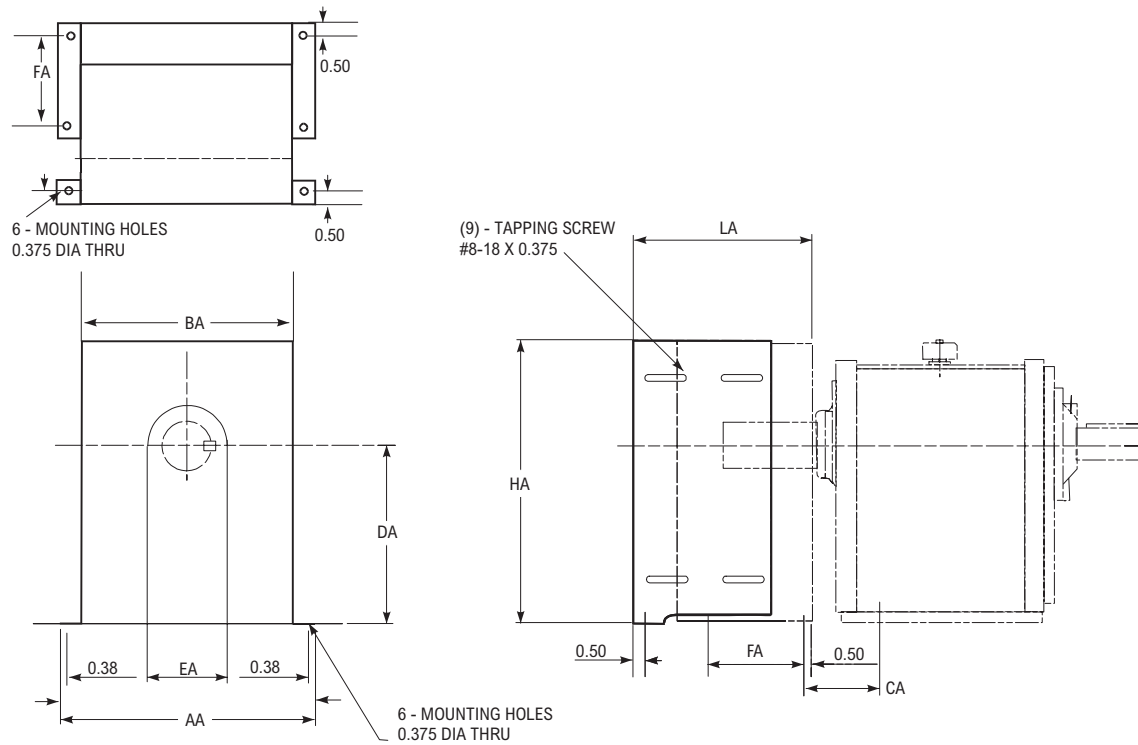

Dimensions (in)

Drive Size	Guard Part Number	AA	BA	CA	DA	EA	FA	HA	LA Min-Max	Max Coupling Size	
										Type T	Type G
2040	787354	13.05	10.55	3.68	8.50	4.00	3.75	13.77	6.27-11.15	1080	1030
2050	787355	13.42	10.92	3.91	9.60	4.50	5.00	15.06	7.65-13.65	1090	1030
2060	787356	15.10	12.55	3.22	10.60	4.75	5.75	16.90	8.40-15.15	1100	1035
2070	787357	16.05	13.55	3.44	11.66	5.25	7.25	18.44	9.88-18.14	1110	1040
2080	787358	17.30	14.80	3.72	12.78	5.50	7.75	20.18	10.41-19.16	1120	1045
2090	787359	18.80	16.30	4.24	15.74	6.00	9.38	23.89	12.02-22.40	1130	1050
2100	787360	20.30	17.80	4.89	17.40	6.50	11.00	26.30	13.32-25.65	1140	1055
2110	787361	23.05	20.55	5.00	19.50	7.00	11.75	29.76	14.41-27.16	1150	1060
2120	787362	24.80	22.30	5.34	21.90	7.50	13.25	33.05	15.90-30.15	1160	1070
2130	787363	27.41	25.05	5.90	24.70	8.30	14.75	37.23	17.40-33.15	1170	1070



FALK™

Regal Rexnord

Contact us: [rexnord.com/contact](https://www.regalrexnord.com/contact)
[regalrexnord.com](https://www.regalrexnord.com)

The proper selection and application of products and components, including assuring that the product is safe for its intended use, are the responsibility of the customer. To view our Application Considerations, please visit <https://www.regalrexnord.com/Application-Considerations>.

To view our Standard Terms and Conditions of Sale, please visit <https://www.regalrexnord.com/Terms-and-Conditions-of-Sale> (which may redirect to other website locations based on product family).

"Regal Rexnord" is not indicative of legal entity. Refer to product purchase documentation for the applicable legal entity. Regal Rexnord, Falk, Rexnord, Steelflex, and UltraMax are trademarks of Regal Rexnord Corporation or one of its affiliated companies.

© 2014, 2026 Regal Rexnord Corporation, All Rights Reserved. MCC-311-110-FK-EN-US 04/26

 **RegalRexnord™**

