



Nose-Over Conveyor MatTop Chain

1500, 7526,
1625 & 8500 Series

How to Use the Design Manual

This manual provides general guidelines for using Rexnord products in a nose-over conveyor application including: chain dimensions, basic conveyor design considerations and installation recommendations. Following the suggestions outlined in this manual will ensure proper operation of your conveyor to provide the optimal product handling and optimum chain life. This manual contains information that is specific to Rexnord® 1500, 7526, 1625 and 8500 MatTop® Chain and should be used in conjunction with the **Rexnord Engineering Manual [8rxEM-en](#)**. Manuals can be downloaded from rexnord.com (Resources - Documentation).

Introduction

Typical chain and belt sprockets are approximately 5 to 6 inches (127 to 152 mm) in diameter. For end-to-end transfers, long stationary deadplates are required. Upstream products need to push the containers across the deadplates and can cause tipping or even damage product. In addition, at the end of a shift or production run, containers must be cleared off manually.

Rexnord 1500, 7526, 1625 and 8500 Series MatTop Chains eliminate these long deadplates. These chains are designed with a small pitch. The 1500 Series Chain has a curved bottom contour providing a small transfer length, with little to no chain “kick-up”.

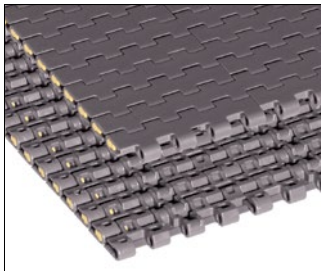

1500 MATTOP CHAIN
has a 0.59-inch (15 mm) pitch
and curved bottom contour

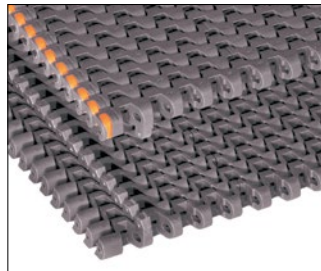

7526 MATTOP CHAIN
has a 0.50-inch (12.7 mm)
pitch and can be used in
side-flexing applications



1625 MATTOP CHAIN
has a 1.00-inch (25.4 mm)
pitch, curved bottom
contour and can be used in
side-flexing applications

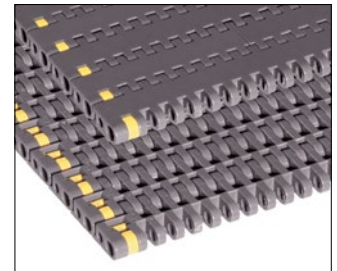

8500 MATTOP CHAIN
has a 0.75-inch (19.1 mm)
pitch



As products are becoming less stable, conveyor applications are becoming more demanding. This makes Rexnord nose-over chains ideal for these lighter, less stable containers — especially empty aluminum cans and PET bottles.

CONTENTS

How to Use the Assembly Instructions	1
Safety Considerations	2
Introduction	3
Nose-Over Transfer Types	6
1500 Series	8
7526 Series	18
1625 Series	21
8500 Series	26
Drive Configurations	33
Carry and Return Ways	37
High-Speed Applications.....	38
Unstable Product Transfer Applications and Adjustability	38

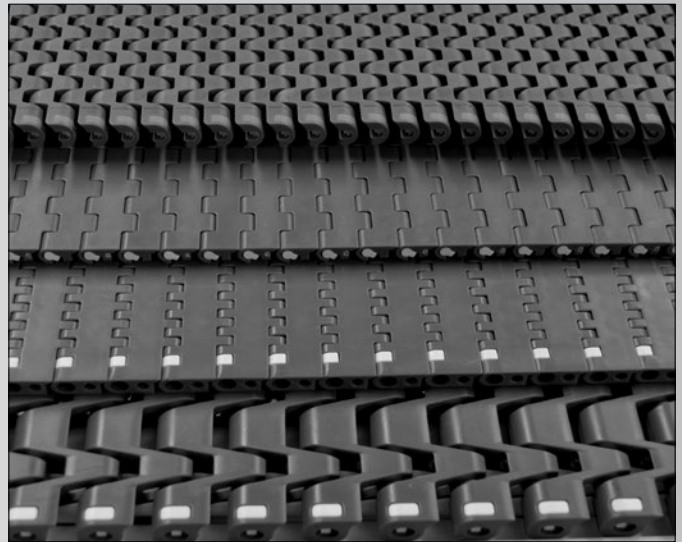

Safety Considerations

PRODUCT SAFETY

Products designed and manufactured by Rexnord are to be used in a safe manner – but Rexnord cannot warrant their safety under all circumstances. Purchaser must install and use products in a safe and lawful manner in compliance with applicable health and safety regulations, laws and general standards of reasonable care. If purchaser fails to do so, purchaser shall indemnify Rexnord from any loss, cost or expense resulting directly or indirectly from such failure.

SAFETY DEVICES

Products are provided with only safety devices identified herein. It is the responsibility of the purchaser to furnish appropriate guards for machinery parts in compliance with msha or osha standards, as well as any other safety devices desired by purchaser and/or required by law. If purchaser fails to do so, purchaser shall indemnify Rexnord from any loss, cost or expense resulting directly or indirectly from such failure.

Introduction

To complement the MatTop Chain, Rexnord offers four nose-over transfer designs to successfully transfer products from one conveyor to the next:



Dynamic Nose-Over Bar (1500 and 8500 Series)

- The first design is a dynamic nose-over bar which utilizes bearings captured in a bar to create a rolling surface instead of a sliding surface. The rolling elements help to reduce wear on the bar and chain, which is especially critical on transfers of unstable product.



Dynamic Nose-Roller Bar (1625 Series)

- The second design is a dynamic nose-roller bar which utilizes a bearing/roller assembly captured in a bar to create a rolling surface instead of a sliding surface. The rolling elements help to reduce wear on the bar and chain, which is especially critical on transfers of unstable product.



Static Modular Nose-Over Bar (1500 Series)

- The third design is a patented stationary nose-over bar that has a modular design to accommodate all chain widths and eliminate custom fabrication. The wear element is replaceable, which makes it very cost-effective. Conveyors can be designed to allow the nose-over bar to be replaced without having to disassemble the chain, which reduces maintenance costs. The smooth surface and curved chain bottom provides increased surface contact, resulting in decreased wear. The patented nose-over bar was designed specifically for Rexnord 1500 Series MatTop Chain.
- Modular nose-over bar kits are offered in standard and low profile versions. The low profile version allows the chain to be wrapped 180° around the nose-over bar without breaking contact, therefore maximizing surface contact and minimizing noise.



Small Sprocket (1500 and 8500 Series)

- The fourth design utilizes a small tooth sprocket which is ideal for reducing friction, noise and vibration.

Introduction

This manual provides general guidelines for using Rexnord products in a nose-over conveyor application including: chain dimensions, basic conveyor design considerations and installation recommendations. Following the suggestions outlined in this manual will ensure proper operation of your conveyor to provide the optimal product handling and optimum chain life. This manual contains information that is specific to Rexnord 1500, 7526, 1625 and 8500 MatTop Chain and should be used in conjunction with the **Rexnord Engineering Manual** ([8rxEM-en](#)).

CONVEYOR DESIGNS differ from Original Equipment Manufacturers (OEMs) and could deviate from our standard general guidelines. An example would be a different approach to transferring product across adjacent nose-over chains. One method steps down the product from the infeed chain onto the transfer plate, and then step down again onto the outfeed chain. A second method keeps both the infeed and outfeed chains level to each other with the nose-over transfer plate orientated slightly lower. Both methods are shown below for reference. The first method is shown throughout the design manual; however, both methods are acceptable transfer systems.

Transfer plate and outfeed chain both step down from the infeed chain

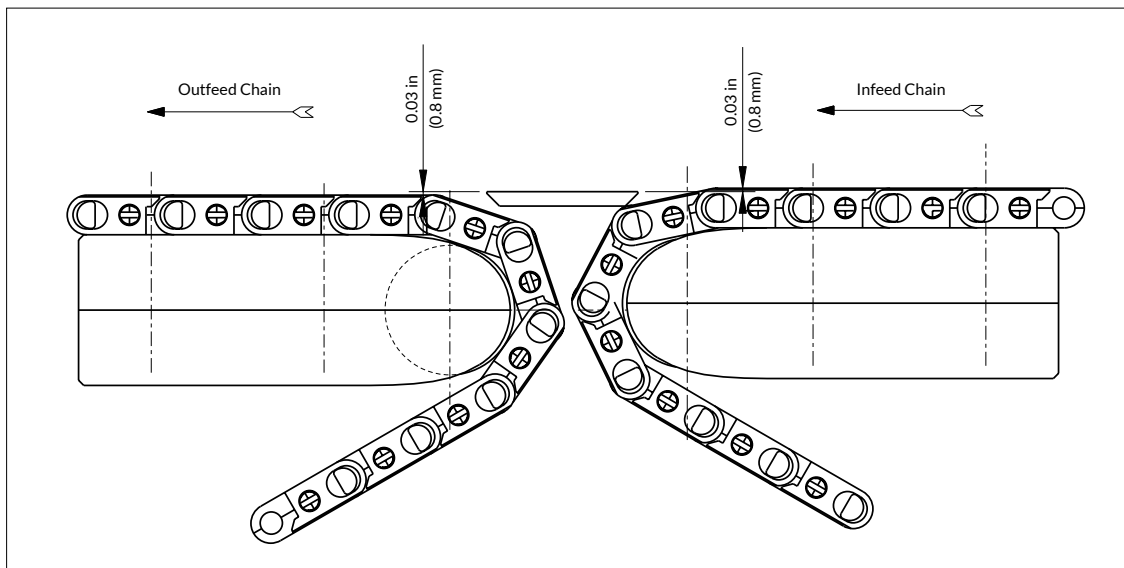

Infeed chain and outfeed chain are level to each other and the transfer plate steps down

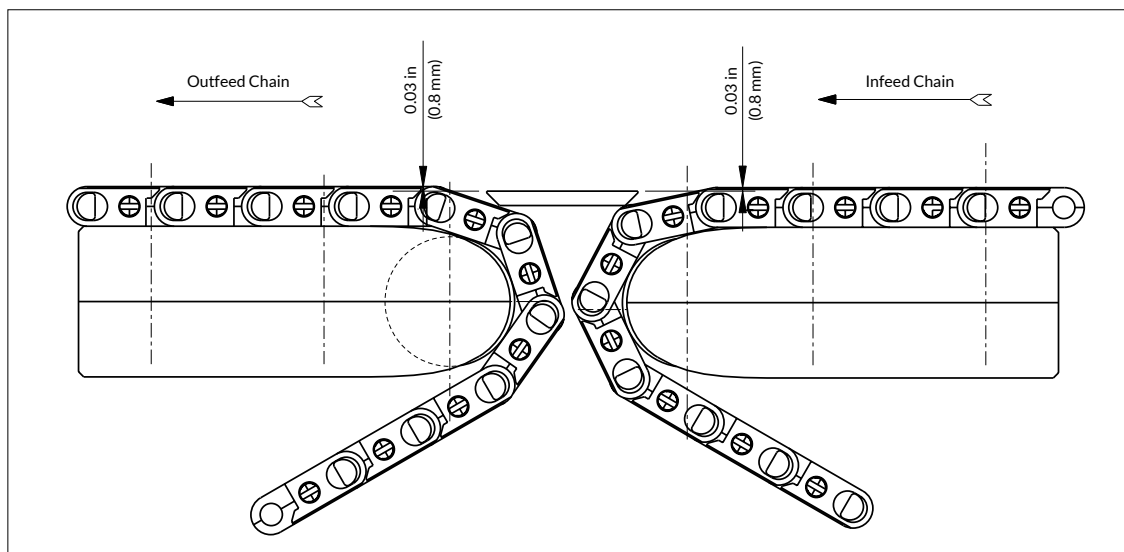

Introduction

Center to Center Nose Bar Distance (A)

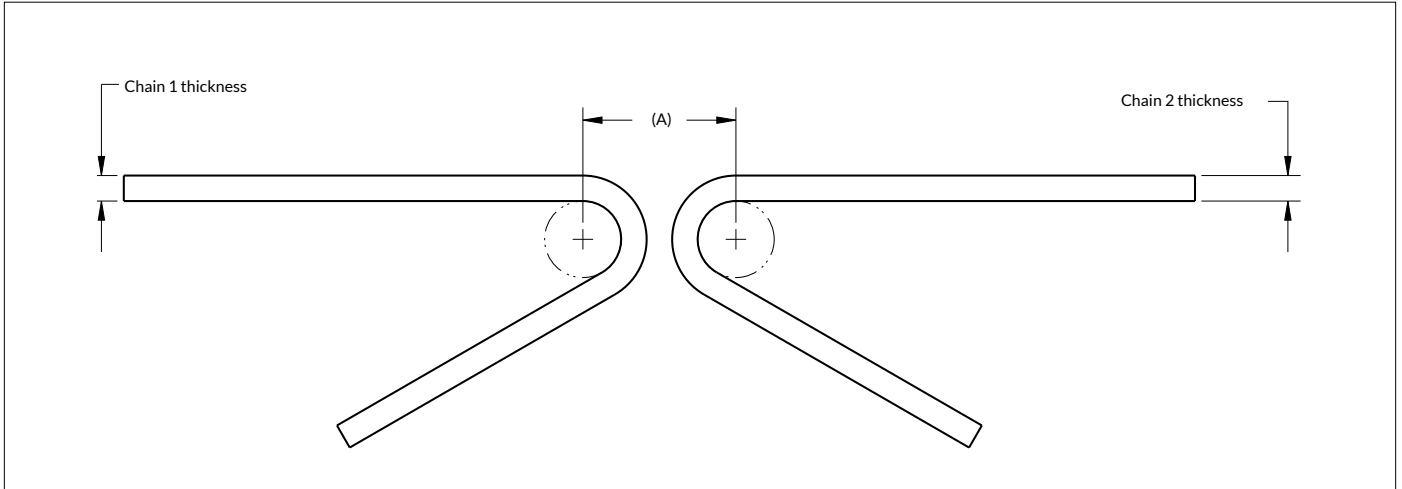

Center to Center Nose Bar Distance (A)

Chain 1		Chain 2		(A) Dimension
Chain Series	Chain Thickness	Chain Series	Chain Thickness	
1505/06	0.34 in (8.7 mm)	1505/06	0.34 in (8.6 mm)	1.53 in (38.8 mm)
1505/06	0.34 in (8.6 mm)	1505RT	0.43 in (10.9 mm)	1.58 in (40.1 mm)
1505/06	0.34 in (8.6 mm)	1503	0.40 in (10.2 mm)	1.59 in (40.4 mm)
1505/06	0.34 in (8.6 mm)	1553	0.85 in (21.5 mm)	1.92 in (48.8 mm)
1505RT	0.43 in (10.9 mm)	1505RT	0.43 in (10.9 mm)	1.64 in (41.7 mm)
1505RT	0.43 in (10.9 mm)	1503	0.40 in (10.2 mm)	1.65 in (41.9 mm)
1505RT	0.43 in (10.9 mm)	1553	0.85 in (21.6 mm)	1.99 in (50.5 mm)
1503	0.40 in (10.2 mm)	1503	0.40 in (10.2 mm)	1.66 in (42.2 mm)
1503	0.40 in (10.2 mm)	1553	0.85 in (21.6 mm)	2.00 in (50.8 mm)
1553	0.85 in (21.6 mm)	1553	0.85 in (21.6 mm)	2.43 in (61.7 mm)

Nose-Over Transfer Types – End-to-End

There are two types of nose-over transfers: End-to-end transfers and 90° transfers. Both types of transfers typically require a deadplate to span the gap between the two chains. The deadplate may not be required if the product is large enough to span the gap. The chart below provides the minimum deadplate width required per chain series.

End-to-End Nose-Over Transfer shown with 1500 Series MatTop

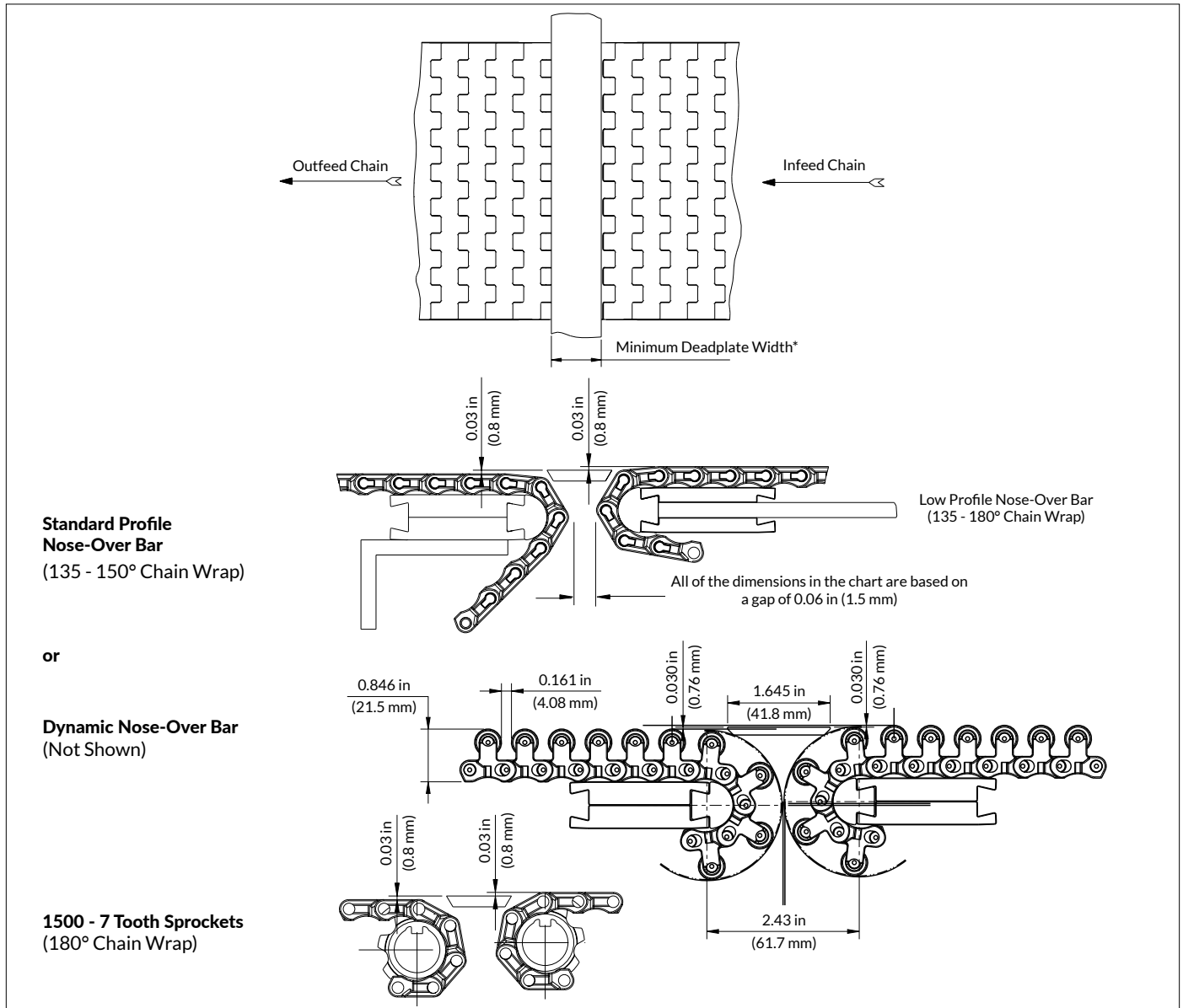

Minimum Deadplate Width per Chain Series

Chain Series	Minimum Deadplate Width		
	with Nose-Over Bar	Sprocket Size	with Small Sprocket
1505/06	0.89 in (22.6 mm)	7T	1.12 in (28.4 mm)
1503	1.03 in (26.2 mm)	7T	1.20 in (30.5 mm)
1505RT	1.08 in (27.4 mm)	7T	1.31 in (33.3 mm)
1553 LBP	1.65 in (41.9 mm)	7T	1.96 in (49.8 mm)
7526	1.24 in (31.5 mm)	N/A	N/A
7526 PT	1.47 in (37.3 mm)	N/A	N/A
1625B-TAB	1.99 in (50.5 mm)	9T	2.49 in (63.2 mm)
8505/06	1.31 in (33.3 mm)	10T	1.93 in (49.0 mm)
8505SG	1.67 in (42.4 mm)	10T	2.29 in (58.2 mm)

Nose-Over Transfer Types – 90°

90° Nose-Over Transfer shown with 1500 Series MatTop

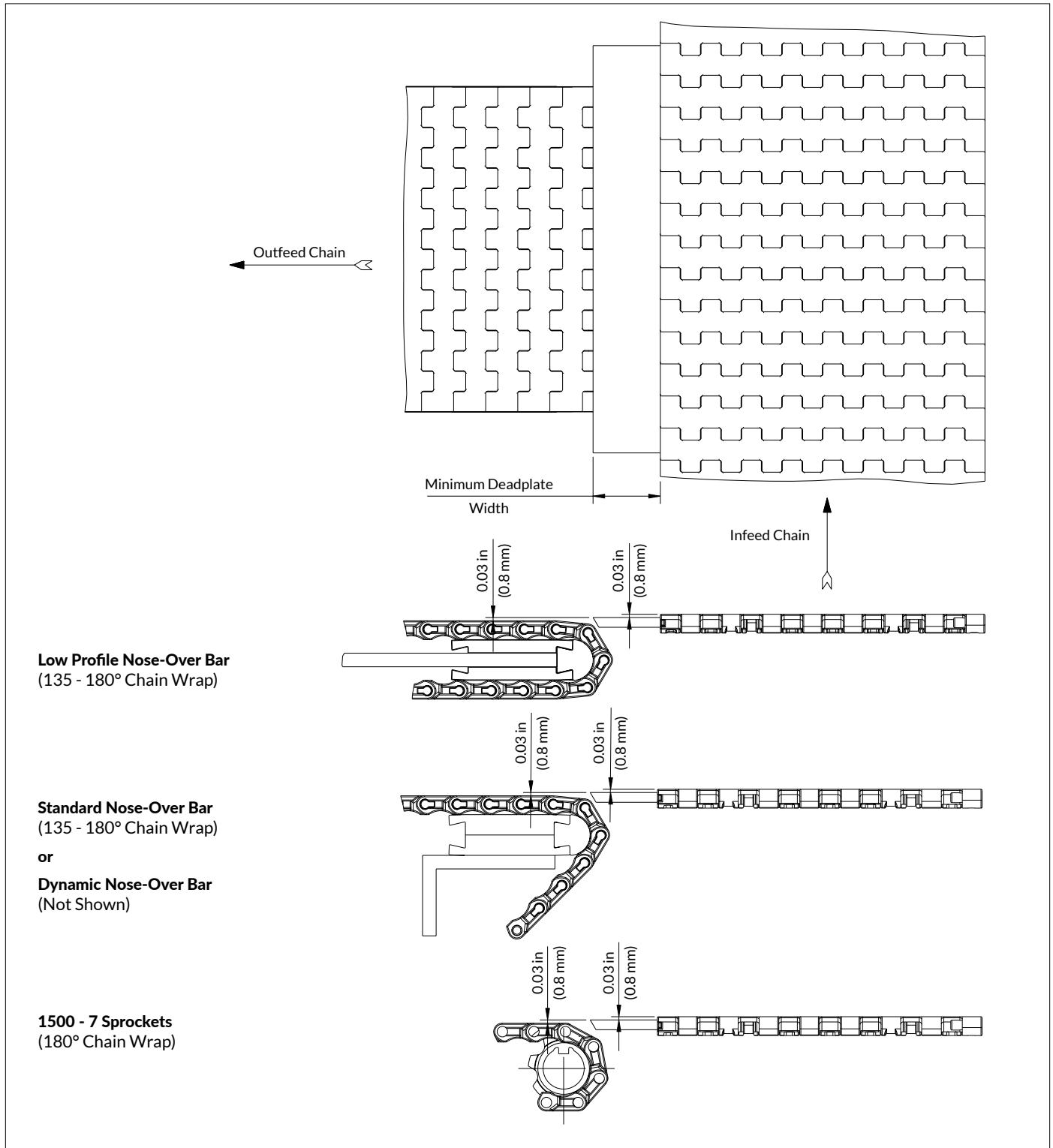

The Dynamic Transfer System™ (DTS) will accomplish a self clearing 90° transfer without the use of a deadplate. (Details can be found in the **Rexnord Engineering Manual** [8rxEM-en](#) in the Conveyor Design Recommendations section for MatTop Chain).

1500 Series – Components

NOSE-OVER BAR KITS

Dynamic Nose-Over Bar

- Standard material for nose-over bar is Ultra High Molecular Weight Polyethylene (UHMWPE).
- Uses standard 5/16-inch or M8 flat head screws (not included).
- Multiple modular nose-over bars can be used side-by-side to obtain a variety of widths. However, they can not be cut to smaller widths.

1500 Series Dynamic Nose-Over Bar



Standard Profile Kit

- Kits include two clamping plates and one nose-over bar (replaceable wear element).
- Standard material for nose-over bar (replaceable wear element) is lubricated wear-resistant nylon, and the base is reinforced nylon.
- Uses standard 5/16-inch or M8 flat head screws (not included) for mounting.
- Multiple modular nose-over bars can be used side-by-side to obtain a variety of widths.

1500 Series Standard Profile Kit



Low Profile Kit

- Kits include two clamping plates and one nose-over bar (replaceable wear element).
- Standard material for nose-over bar (replaceable wear element) is lubricated wear-resistant nylon, and the base is reinforced nylon.
- Hardware is included.
- Multiple modular nose-over bars can be used side-by-side to obtain a variety of widths.

1500 Series Low Profile Kit



Replaceable Wear Elements

- Standard material for nose-over bar (replaceable wear element) is lubricated wear-resistant nylon, and the base is reinforced nylon.
- Other widths are available.

1500 Series Replaceable Wear Element



Dynamic Nose-Over Bar Parts for 1500 Series MatTop Chain

Style	Part Number	Overall Length	Hardware
Dynamic Nose-Over Bar Kit	10148213	18 in (457 mm)	None
Dynamic Nose-Over Bar Kit	10148214	24 in (609 mm)	None
Standard Profile Kit	10148210	6 in (152 mm)	None
Low Profile Kit	10148211	6 in (152 mm)	M6
Low Profile Kit	10148212	6 in (152 mm)	1/4-20
Replaceable Wear Element*	10187251	6 in (152 mm)	None

* One part number consists of six nose-over bars (each bar is 6.00 inch [152.4 mm] long)

1500 Series – Components

N1500-7T SPROCKET WITH RETAINING RINGS

- Two sprocket halves and two retaining rings are provided per part as shown below.
- Small pitch diameter sprocket is ideal for tight end-to-end transfers and low profile conveyors.
- Available in two bore styles: integral key (shown below) and idler bore (not shown).
- Integral key is cost-effective because it eliminates key stock and is easy to assemble – fits standard keyway and does not require a setscrew.
- Bores available to fit standard 0.75-inch (20.0 mm) shafting.

N1500-7T Sprocket with Integral Key



Two Sprocket Halves and Retaining Rings



General Notes: A polyester pin **MUST** be used for all nose-over applications – the polyester pin should be specified when ordering. The only exception is Tough Composite Friction Top (TCF) chains which should utilize the standard acetal pin.

- Small 0.59-inch (14.9 mm) pitch is ideal for handling small, unstable products.
- The minimum deadplate widths for 1500 Series MatTop Chain is shown on [page 5](#).
- Curved bottom contour for smooth operation over tight nose-over transfers – improved sliding wear life by virtue of full surface contact between bottom of chain and nose-over bar.
- When using TCF chains on UHMWPE nose-over bars, normally the UHMWPE bars will wear faster than the chain. UHMWPE wear elements are available on a Made-to-Order (MTO) basis. When using TCF chains on lubricated wear-resistant nylon nose-over bars, normally the chain will wear faster than the nose-over bars.
- The Low Backline Pressure (LBP) rollers on 1503 chain extend 0.06-inch (1.5 mm) above the chain surface. The Low Backline Pressure (LBP) rollers on the 1553 chain extend 0.51-inch (12.9 mm) above the chain surface. The RubberTop surface on TCF and HTF1505 Chain extend 0.09-inch (2.2 mm) above the chain surface. These dimensions must be taken into account when designing nose-over transfers with LBP and RubberTop chains.

1500 Series – Mounting Information

STATIC MODULAR NOSE-OVER BAR – STANDARD PROFILE

- Standard nose-over kits should be used for wide conveyors that need more rigid support under nose-over.
- Standard profile nose-over kits are not furnished with fasteners.
- Nose-over kits should use 5/16-18 or M8 flat head cap screws (not included).

Standard Nose-Over Profile Mounting

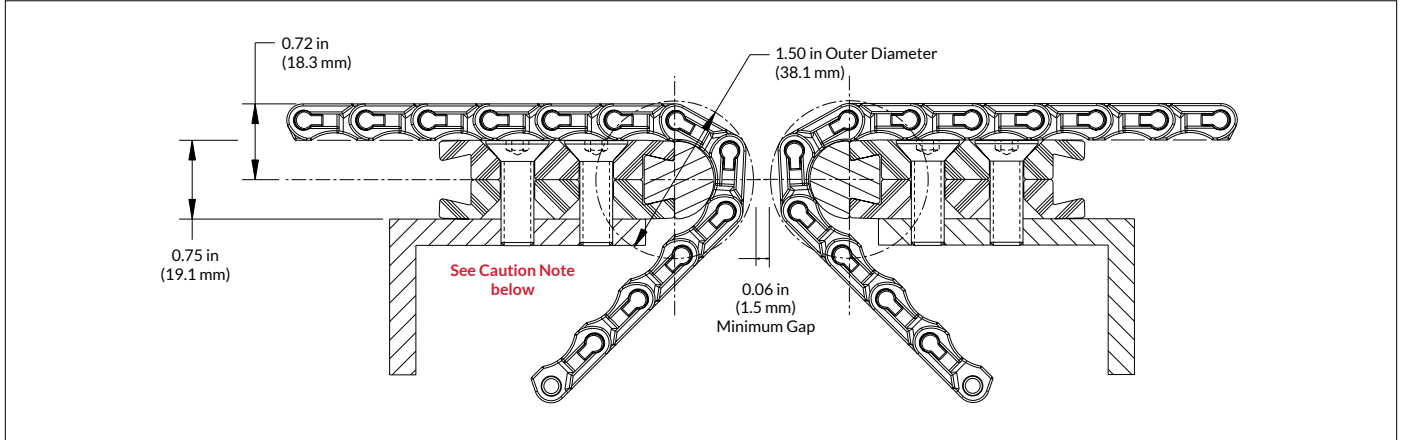

Standard Nose-Over Profile Mounting

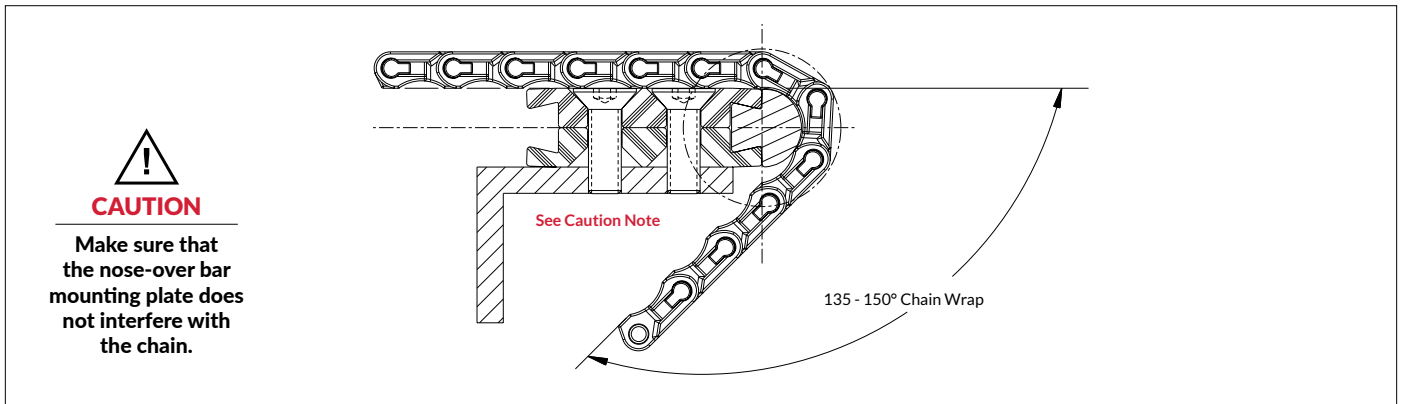

Standard Nose-Over Profile Mounting

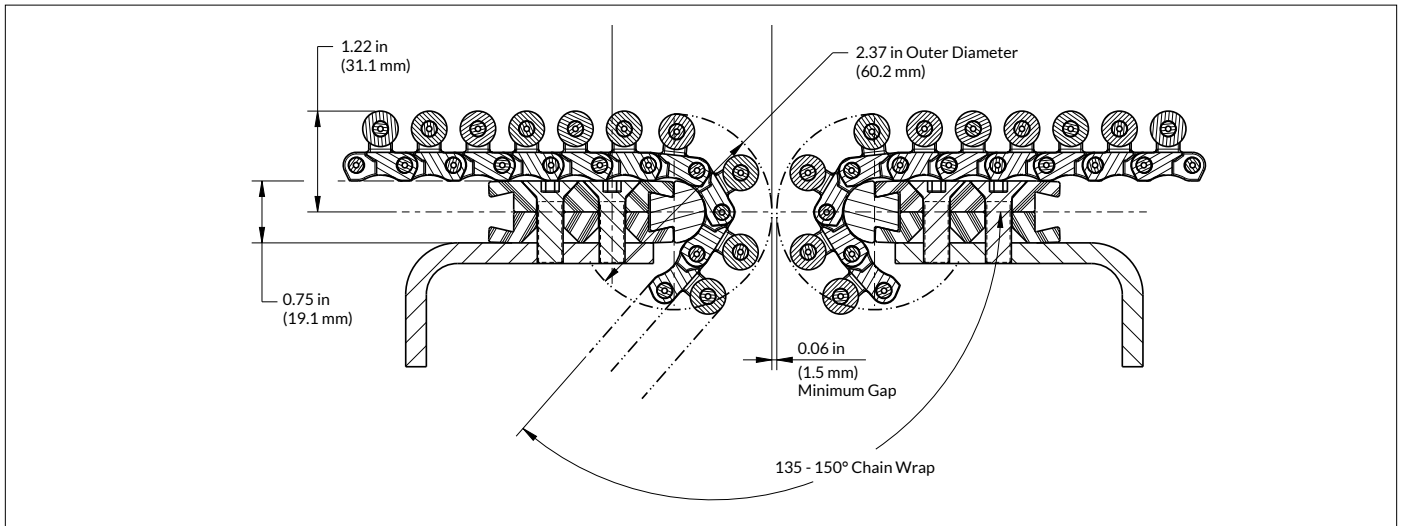

1500 Series – Mounting Information

STATIC MODULAR NOSE-OVER BAR – LOW PROFILE

- Low profile nose-over kits are suitable only for narrow conveyor widths and are limited by deflection of the 0.25-inch (8 mm for metric version) thick mounting plate.
- Typically the mounting plate extends the width of the conveyor and is mounted to the conveyor side frames.
- Low profile nose-over kits can obtain a maximum wrap angle of 180°. This allows the chain to be wrapped completely around the nose-over bar without breaking contact, maximizing surface contact and minimizing noise.

Imperial Nose-Over Low Profile Mounting

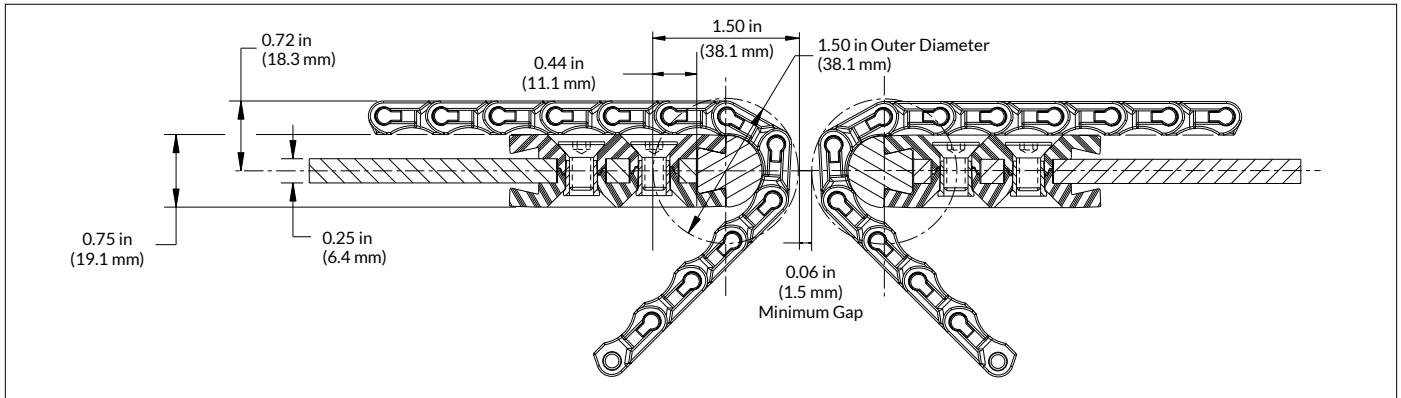

Metric Nose-Over Low Profile Mounting

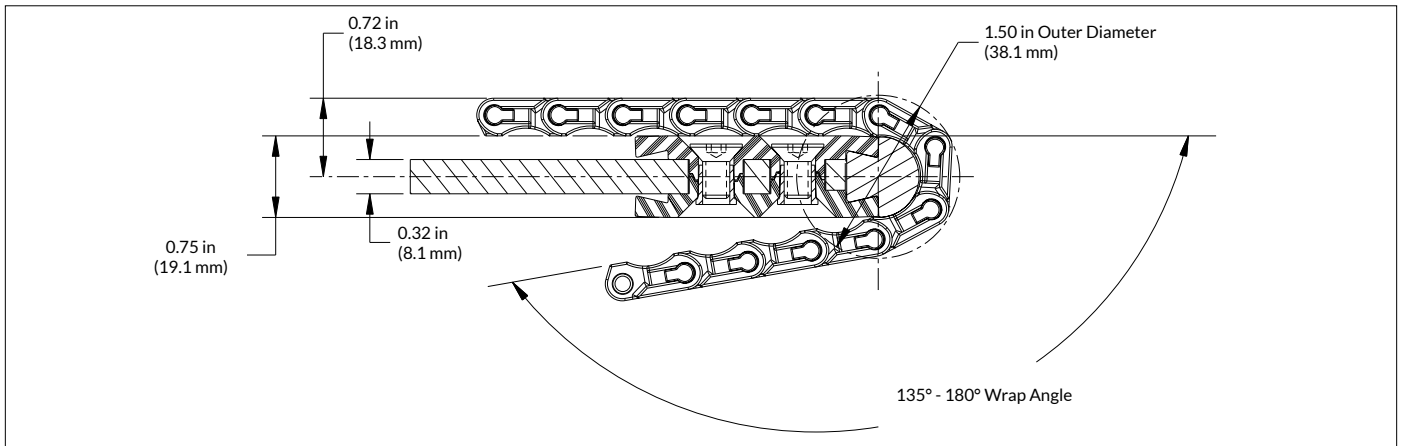

Metric Nose-Over Low Profile Mounting

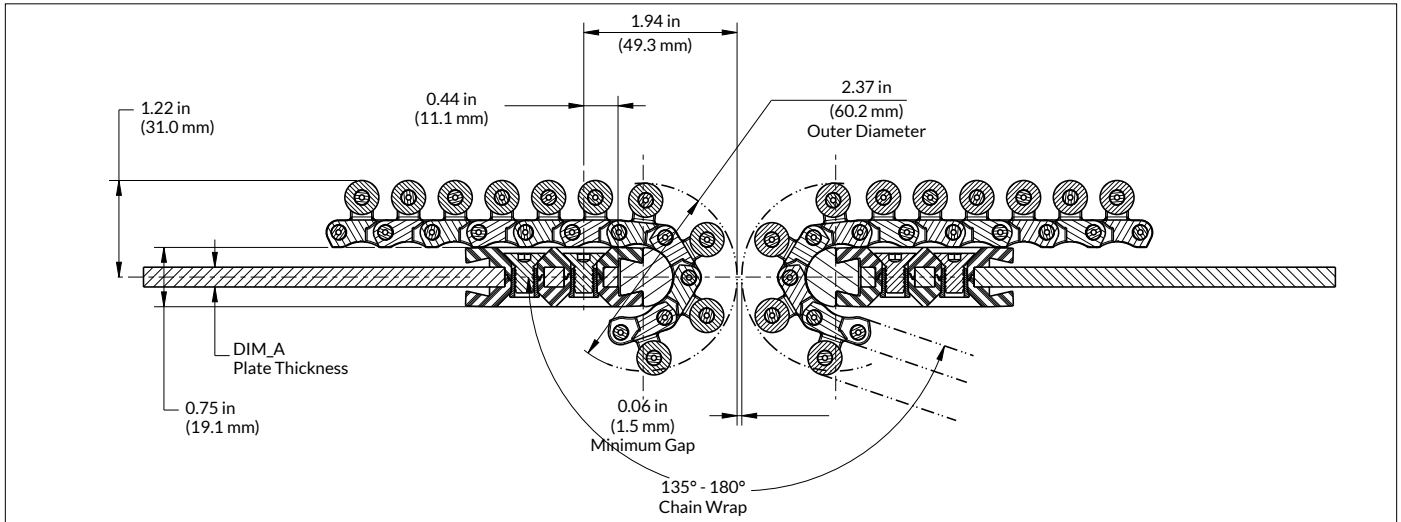

1500 Series – Mounting Information

DYNAMIC NOSE-OVER BAR

- Use standard 5/16-inch or M8 flat head screws for mounting nose-over (not included).
- The dynamic nose-over bar is typically used in applications that handle products that are difficult to convey and/or high speeds.

Dynamic Nose-Over Mounting

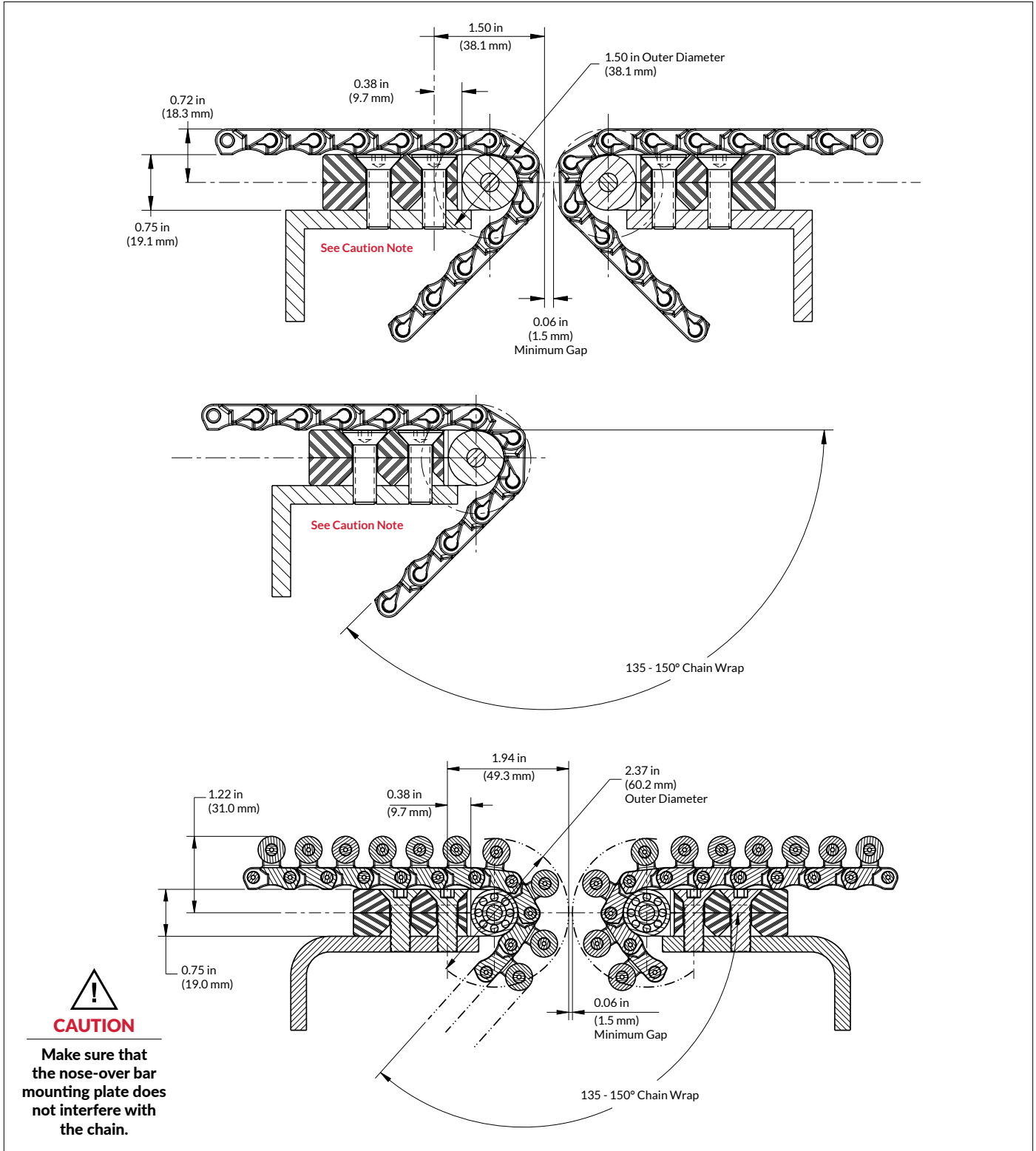

1500 Series – Mounting Information

DYNAMIC NOSE-OVER BAR

Dynamic Nose-Over Mounting

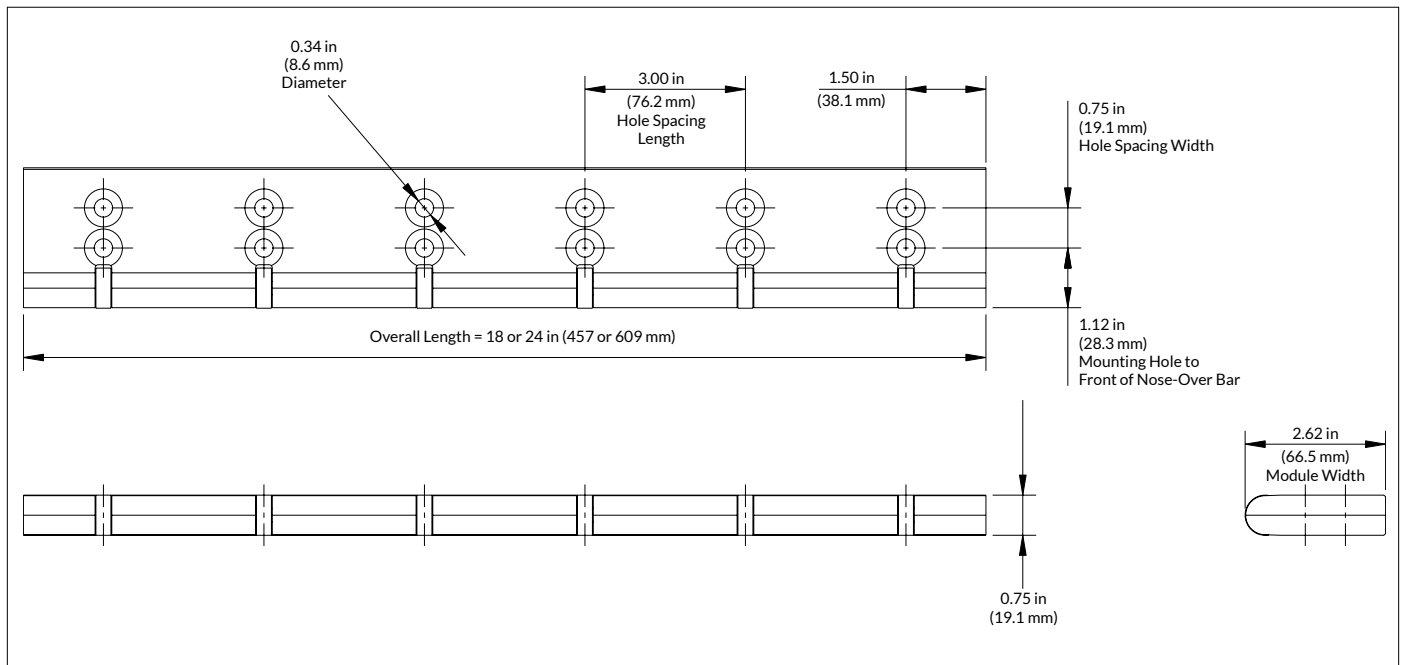

1500 Series – Mounting Information

7-TOOTH SPROCKET

- 7-tooth sprockets are recommended for nose-over transfers to reduce chain tension and minimize noise.
- The minimum transfer plate for this type of a transfer is 1.00-inch (25.4 mm).
- 180° wrap angle is recommended to ensure proper engagement of chain and sprocket.
- A 3/4-inch or 20.0 mm diameter shaft is required. The conveyor width will be limited by bending deflection.
- Recommend maximum bending deflection of shaft to be 0.06-inch (1.5 mm).
- For applications that exceed this deflection, a center support is required (see concept drawings below).
- Use standard ANSI/ASME machine shafting for proper hardness, surface finish and straightness.
- Can be used as an idler or drive sprocket.
- Sprocket locations are shown on **pages 16 & 17**.

1500-7T Sprockets

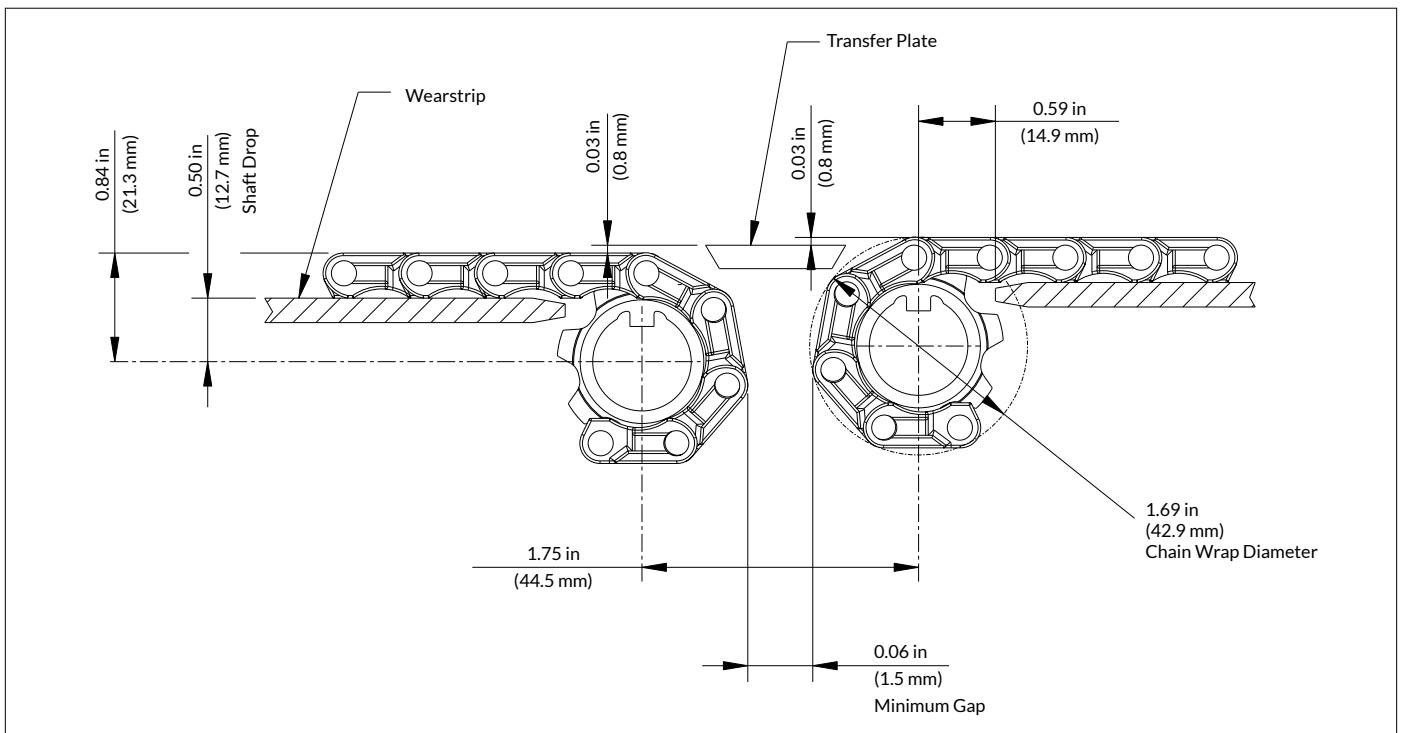

Concept Drawings of Center Shaft Support (not supplied by Rexnord)

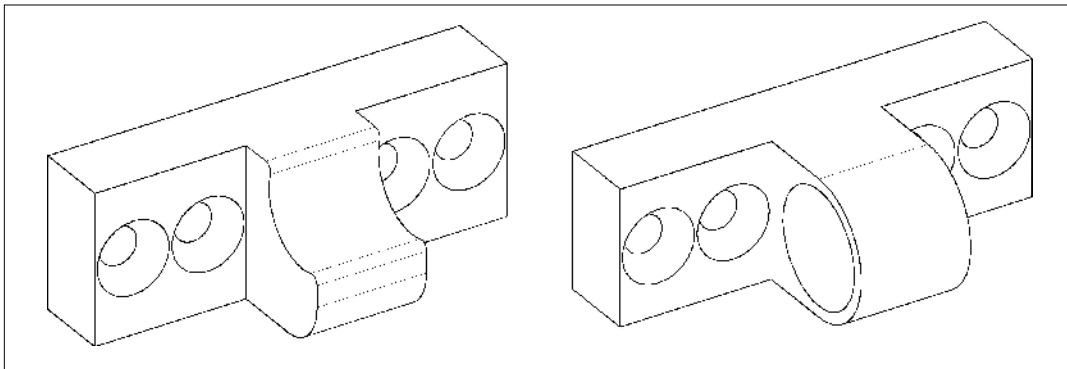

1500 Series – Mounting Information

GENERAL RECOMMENDATIONS (Standard and Low Profile)

It is recommended to extend the nose-over assembly beyond the end of the conveyor frame or otherwise expose the end of the replaceable wear bar to allow replacement without disassembly of components.

Concept of Nose-Over Bar Access for Replaceable Wear Element

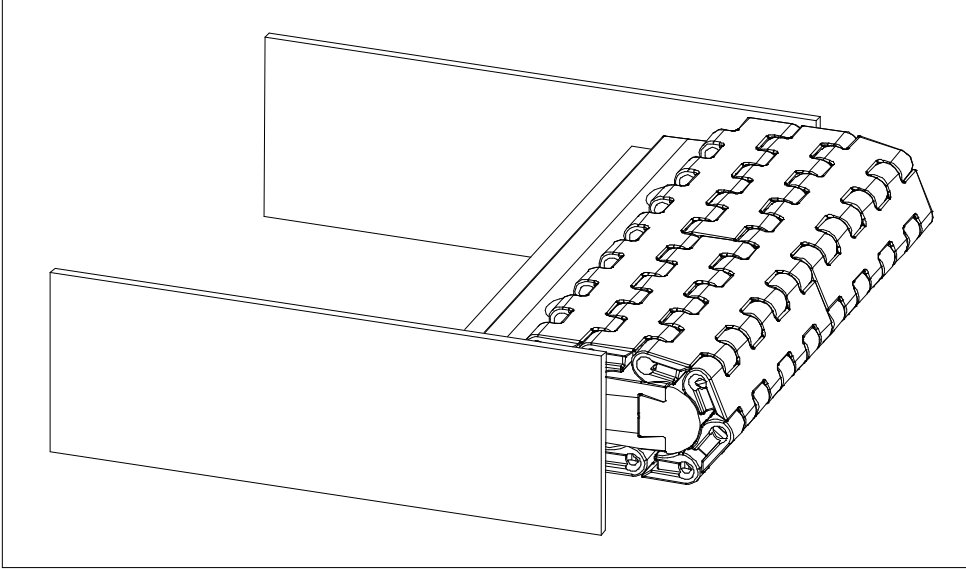

CUT MODULAR NOSE-OVER BARS (Standard and Low Profile)

- Nose-over bar ends should be positioned in a staggered pattern with the ends of the nose-over clamps.
- Clamping plates and wear elements may be cut down the center to create a 3-inch (76 mm) module for custom widths (as shown below).

Example of Cut Modules

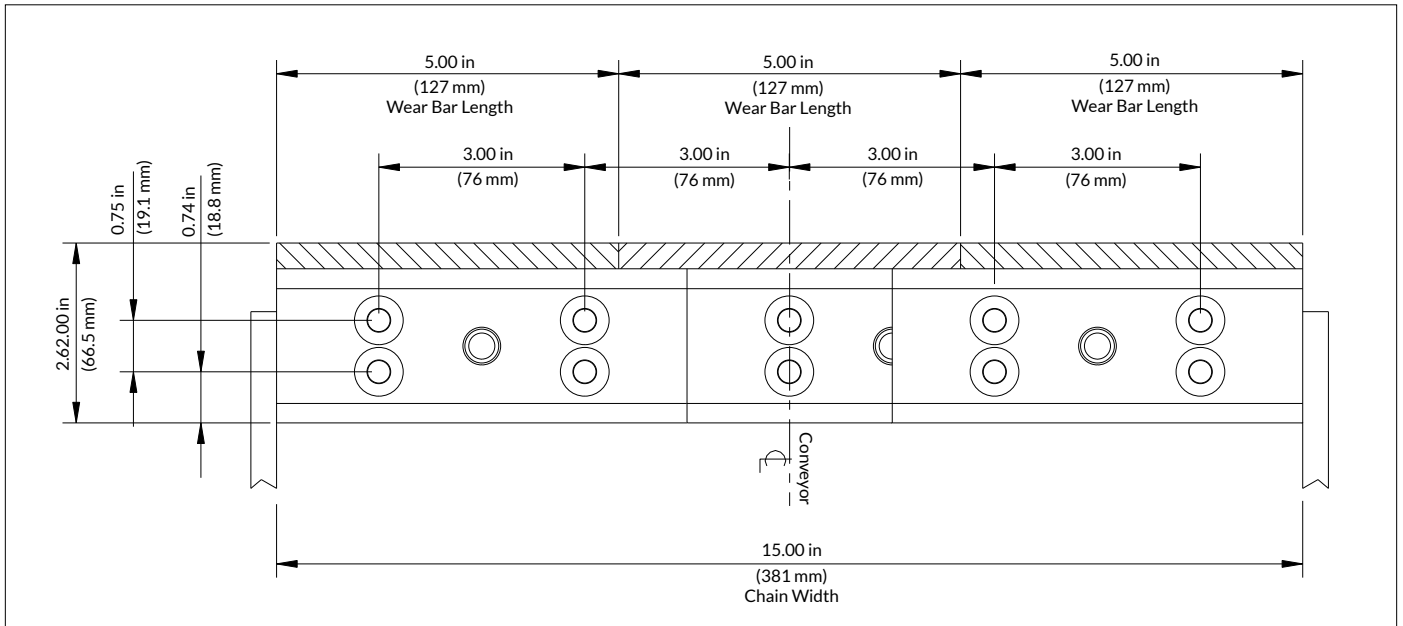

1500 Series – Sprocket Locations

SPROCKET LOCATIONS AND 7T MOUNTING INFORMATION

Sprocket Locations

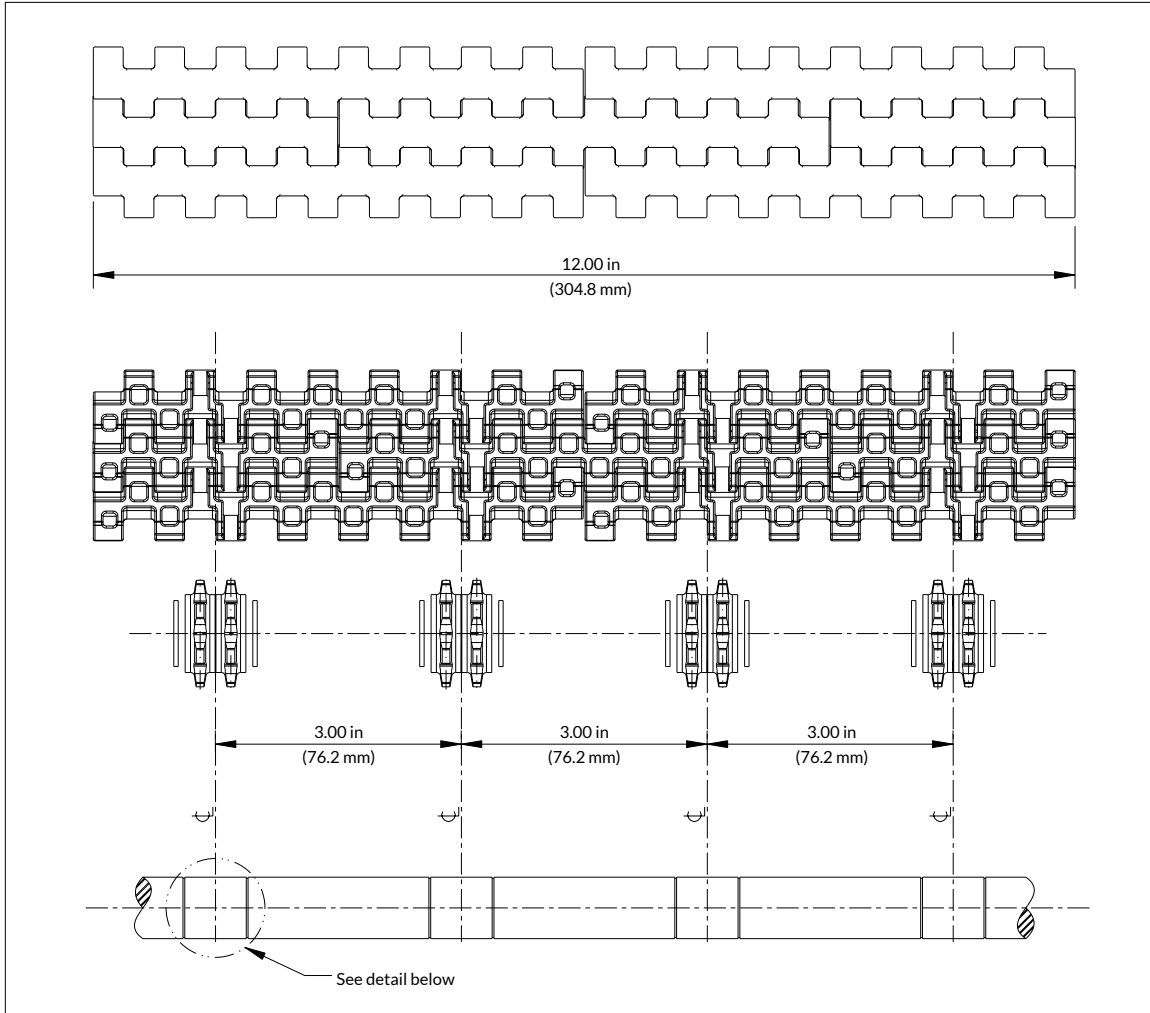

7T Sprocket Mounting Detail

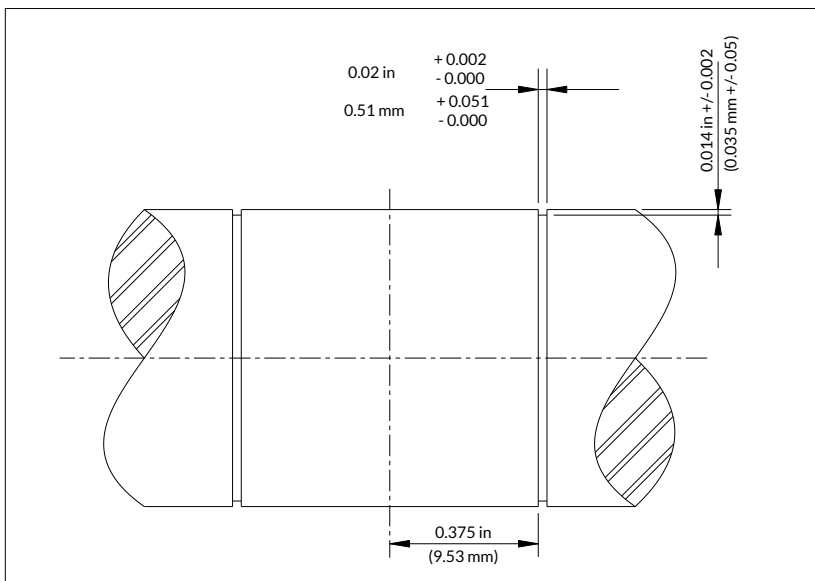

1500 Series – Sprocket Locations

Sprocket Locations

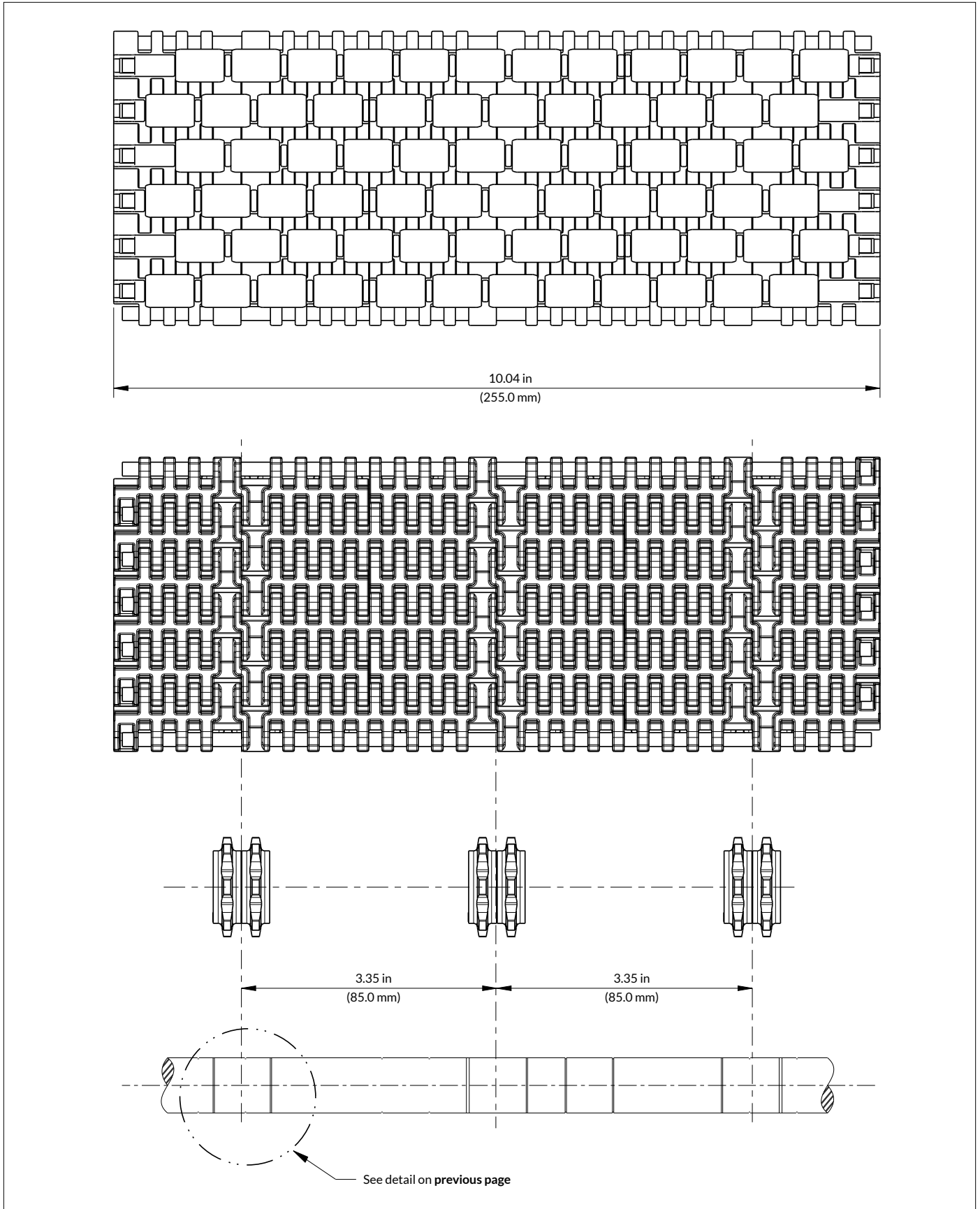

7526 Series – Components

NOSE-OVER BAR DIMENSIONAL INFORMATION

(Nose-Over Bar Not Supplied by Rexnord)

Rexnord does not supply a 7526 nose-over bar; however, the information below provides general dimensional information to match with the 7526 Series MatTop Chain.

7526 Nose-Over Bar Layout

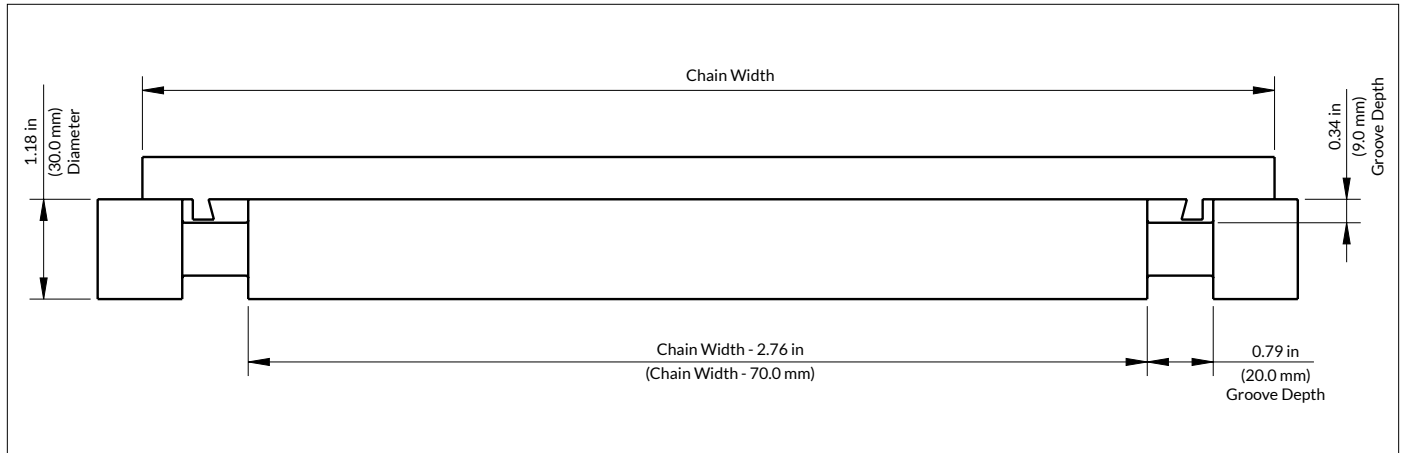

CAUTION

General Notes:

- Small 0.50-inch (12.7 mm) pitch is ideal for handling small, unstable products.
- The minimum deadplate widths for 7526 Series MatTop Chain is shown on [page 6](#).
- The nose-over bar must contain two grooves to accommodate the PosiTrack™ Tracking Guides on both edges of the chain. The chain must be supported on both sides of the PosiTrack Tracking Guides as shown above. These grooves should not be used to track the chain.
- It is recommended to utilize a dynamic nose-over bar whenever possible.
- If a static nose-over bar is utilized, it is strongly recommended to utilize moly-filled material which provides a higher PV limit and allows for more optimum wear.
- See the [7526 MatTop Chain Design Manual \(8rx7526dm-en\)](#) which can be downloaded from rexnord.com (Resources - Documentation) for more details on this chain series.

7526 Series – Components

Center to Center Nose Bar Distance (A)

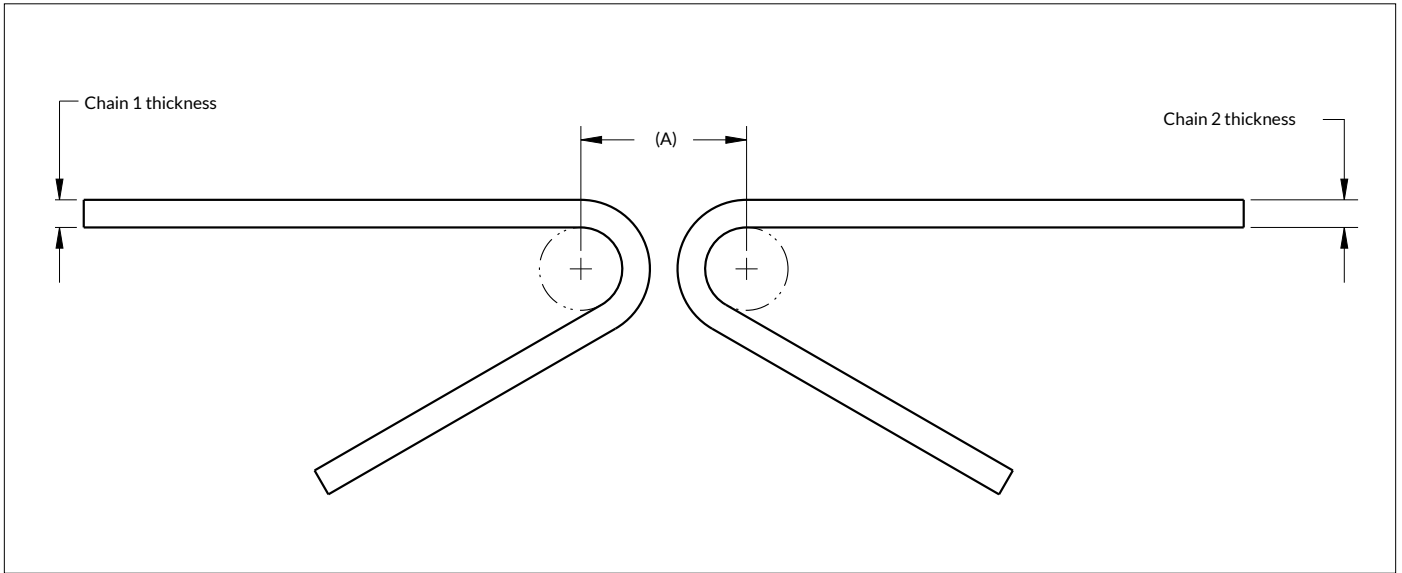

Center to Center Nose Bar Distance (A)

Chain 1		Chain 2		(A) Dimension
Chain Series	Chain Thickness	Chain Series	Chain Thickness	
7526RBT	0.50 in (12.7 mm)	7526RBT	0.50 in (12.7 mm)	2.20 in (55.9 mm)
7526RBT	0.50 in (12.7 mm)	1505/06	0.34 in (8.6 mm)	1.83 in (46.5 mm)
7526RBT	0.50 in (12.7 mm)	1505RT	0.43 in (10.9 mm)	1.90 in (48.3 mm)
7526RBT	0.50 in (12.7 mm)	1503	0.40 in (10.2 mm)	1.90 in (48.3 mm)
7526RBT	0.50 in (12.7 mm)	1553	0.85 in (21.6 mm)	2.31 in (58.7 mm)
7526RBT	0.50 in (12.7 mm)	8505/06	0.34 in (8.6 mm)	2.13 in (54.1 mm)
7526RBT	0.50 in (12.7 mm)	8505RT	0.44 in (11.2 mm)	2.14 in (54.4 mm)
7526RBT	0.50 in (12.7 mm)	8503	0.43 in (10.9 mm)	2.24 in (56.9 mm)
7526RBT	0.50 in (12.7 mm)	1625	0.63 in (15.9 mm)	2.54 in (64.5 mm)

7526 Series – Sprocket Locations

SPROCKET LOCATIONS

- Number of sprockets at drive end: $(\text{Chain Width} / 85 \text{ mm}) + 2$ for curve applications
- Number of sprockets at idler end: $(\text{Chain Width} / 85 \text{ mm})$
- Example: A 340 mm chain requires 6 sprockets at the drive end ($[(340 \text{ mm} / 85 \text{ mm}) + 2 = 6]$)

Sprocket Locations

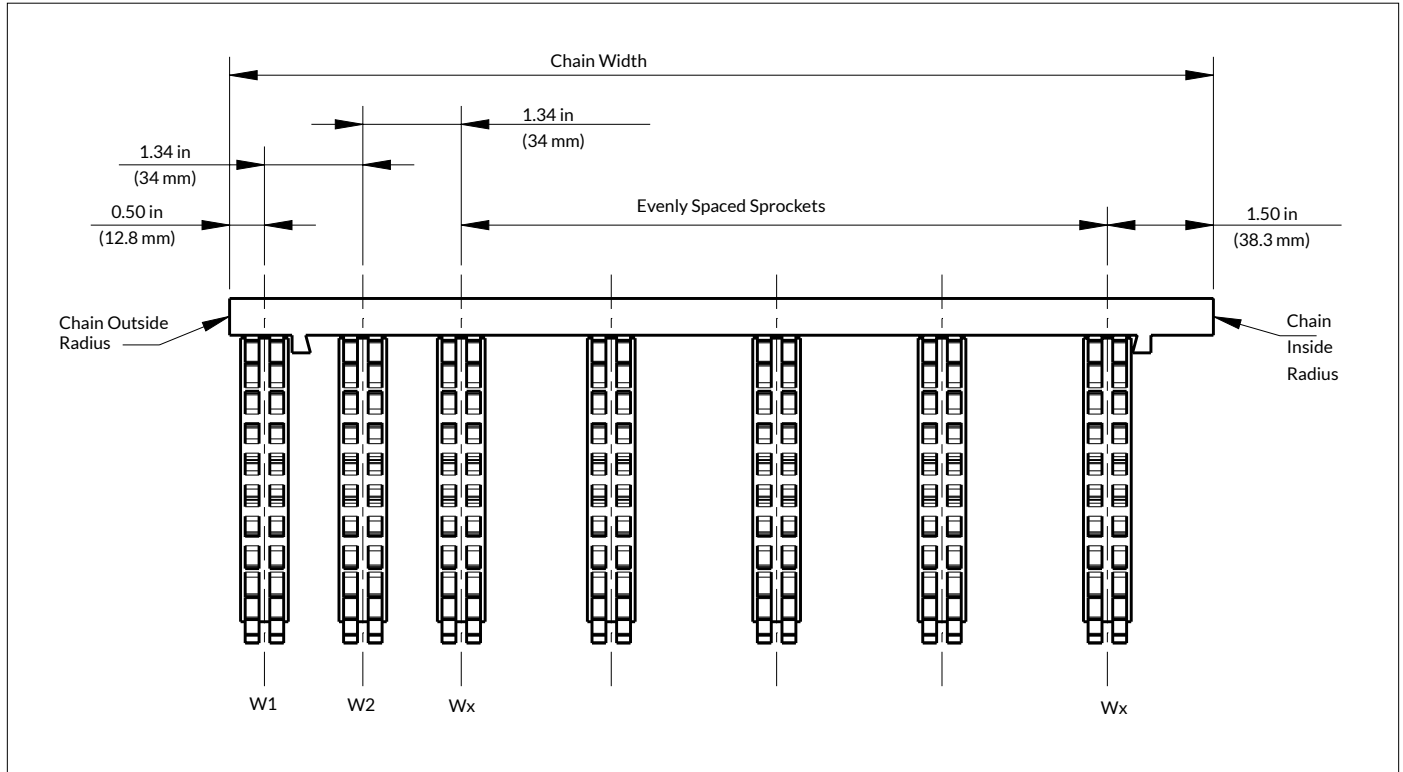

Sprockets W1, W2 and Wx are spaced per the drawing. All of the other sprockets are evenly spaced.



All sprocket bores are oversized for a sliding fit. To properly track the chain over the head and tail shafts, at least one sprocket needs to be secured in position on the shaft (i.e. set collars, snap rings, etc.). This is necessary for both round and square bore sprockets.

1625 Series – Components

DYNAMIC NOSE-ROLLER BAR KITS

- Standard material for nose-roller bar is UHMWPE
- For use with 1625 MatTop chains.
- The optimum nose-roller bar diameter is as follows:
 - 1.625-inch = 1-5/8 in (40 mm) diameter (supplied by Rexnord)
- Uses standard 5/16-inch or M8 flat head screws (not included).
- The modular nose components can be used side-by-side to obtain all of the available widths.

Dynamic Nose-Roller Bar

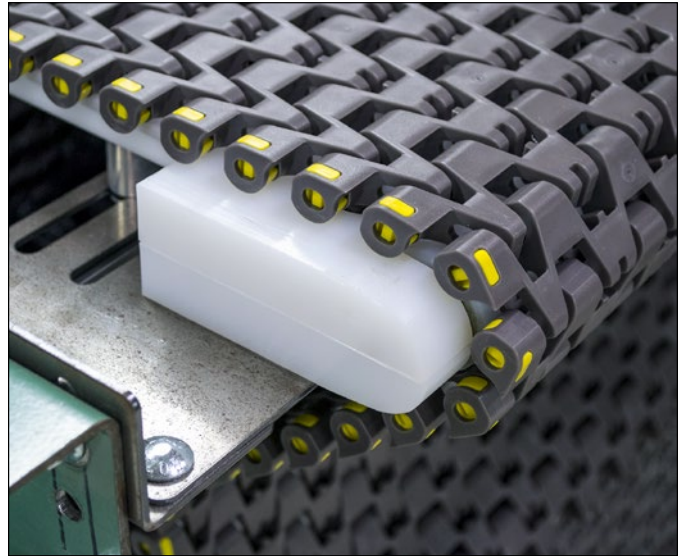

Dynamic Nose-Roller Modules

Style	Part Number	Overall Length	Hardware
Left Blade End Nose-Roller	10355789	4.81 in (122.17 mm)	None
Right Blade End Nose-Roller	10355790	4.81 in (122.17 mm)	None
Center Nose-Roller	10355801	6.00 in (152.4 mm)	None
Plug End Nose-Roller	10355787	3.00 in (76.2 mm)	None

NS7700 SPROCKETS

All current 7700 sprockets are available to drive the chain. Bores available to fit standard 31.438-inch and 19 to 350 mm shafting.

NS7700 Sprocket



General Notes

- A polyester pin **MUST** be used for all nose-over applications – the polyester pin is standard for the 1625 Series MatTop Chain.
- Small 1.00-inch (25.4 mm) pitch is ideal for handling small, unstable products.
- The minimum deadplate widths for 1625 Series MatTop Chain is shown on page 6.
- See the [1625 MatTop Chain Design Manual \(FT3-002\)](#) for more details on this chain series.

1625 Series – Components

Center to Center Nose Bar Distance (A)

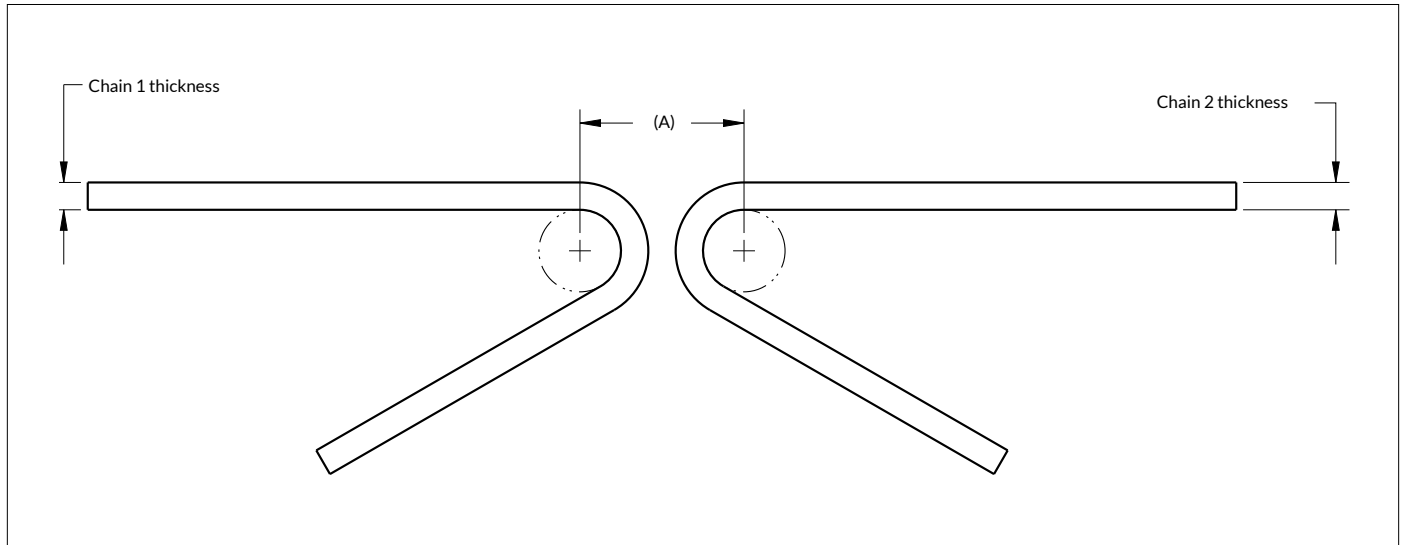

Center to Center Nose Bar Distance (A)

Chain 1		Chain 2		(A) Dimension
Chain Series	Chain Thickness	Chain Series	Chain Thickness	
1625	0.63 in (15.9 mm)	1625	0.63 in (15.9 mm)	2.93 in (74.4 mm)
1625	0.63 in (15.9 mm)	7526RBT	0.50 in (12.7 mm)	2.54 in (64.5 mm)
1625	0.63 in (15.9 mm)	1505/06	0.34 in (8.6 mm)	2.11 in (53.6 mm)
1625	0.63 in (15.9 mm)	1505RT	0.43 in (10.9 mm)	2.20 in (55.9 mm)
1625	0.63 in (15.9 mm)	1503	0.40 in (10.2 mm)	2.20 in (55.9 mm)
1625	0.63 in (15.9 mm)	1553	0.85 in (21.6 mm)	2.67 in (67.8 mm)
1625	0.63 in (15.9 mm)	8505/06	0.34 in (8.6 mm)	2.46 in (62.4 mm)
1625	0.63 in (15.9 mm)	8505RT	0.44 in (11.2 mm)	2.49 in (63.1 mm)
1625	0.63 in (15.9 mm)	8503	0.43 in (10.9 mm)	2.59 in (65.7 mm)

1625 Series – Mounting Information

DYNAMIC NOSE-ROLLER BAR

- The optimum nose-roller bar diameter is as follows:
 - 1625 = 1.625-inch (40 mm) diameter (supplied by Rexnord)
- Uses standard 5/16-inch or M8 flat head screws (not included).
- The modular nose-roller bars can be used side-by-side to obtain all of the available widths; however, they cannot be cut to smaller widths.
- The dynamic nose-roller bar is typically used in applications that handle difficult to convey products and/or high speeds.

Dynamic Nose-Roller Mounting (1625)

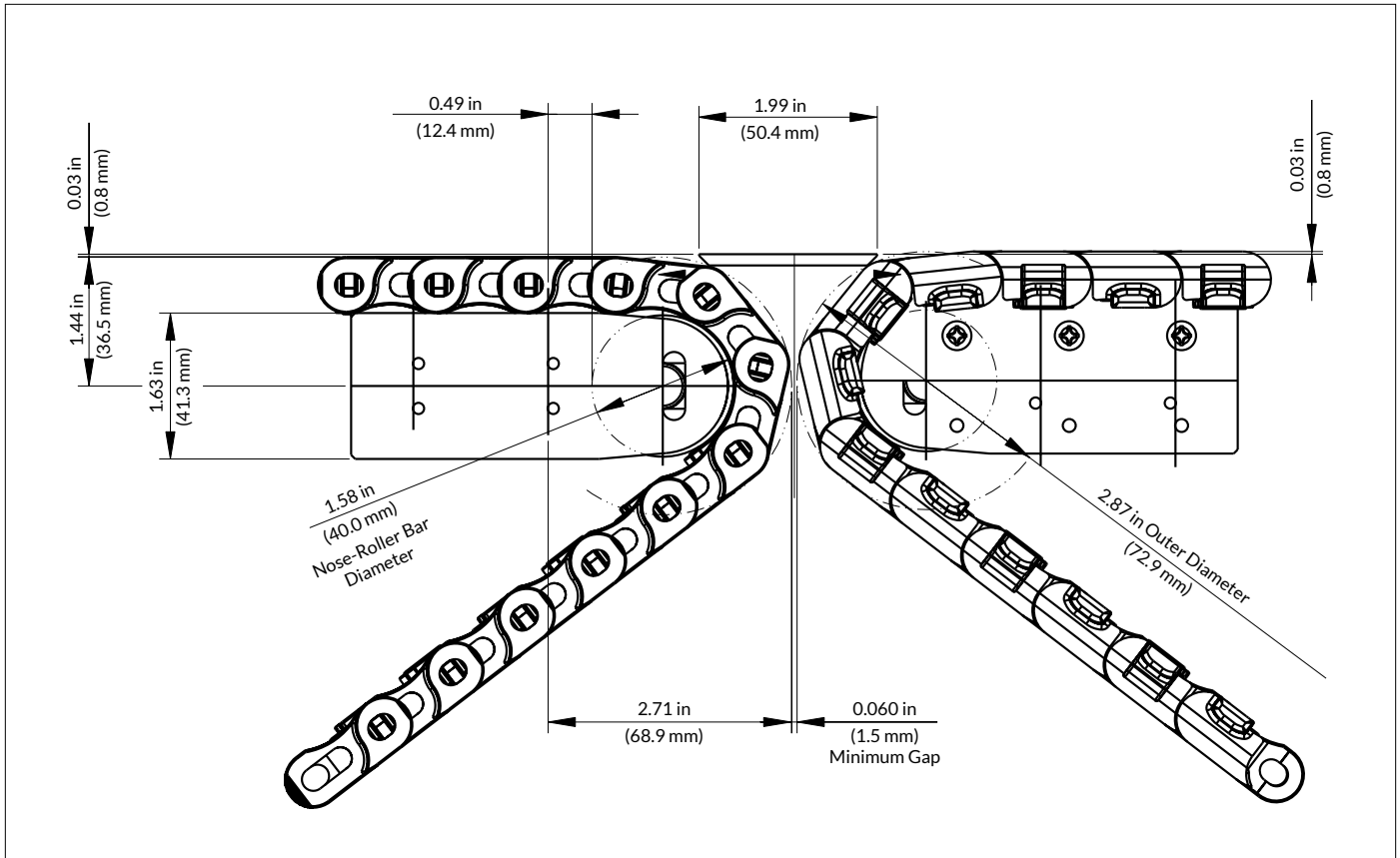

Make sure that the nose-roller bar mounting plate does not interfere with the chain. The chain should be wrapped 135 - 150° around the nose-roller.

1625 Series – Mounting Information

DYNAMIC NOSE-ROLLER BAR

Dynamic Nose-Roller Drawing

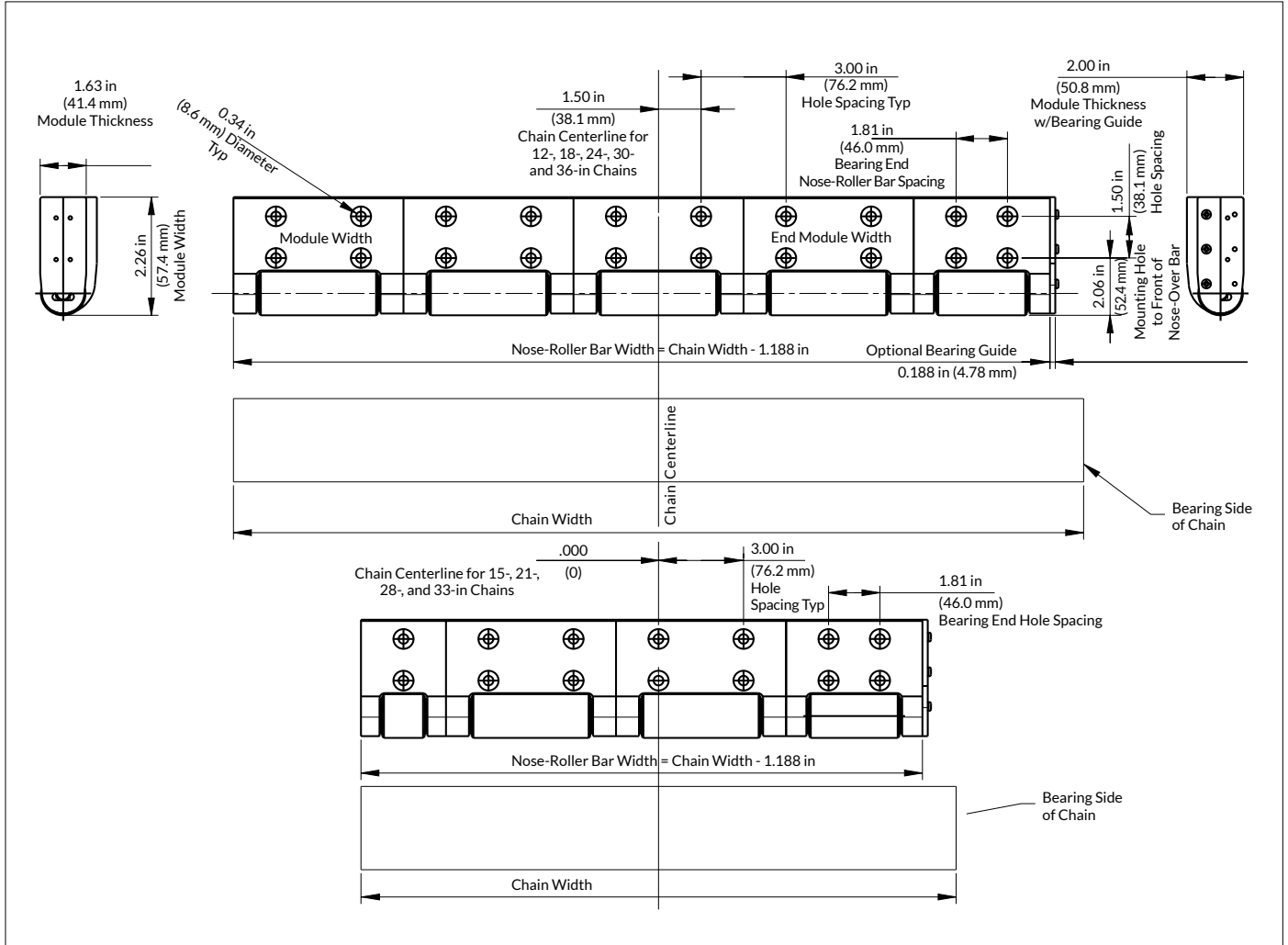

1625 Series – Mounting Information

SPROCKET LOCATIONS

The 1625 MatTop Chain design requires 1 sprocket per 3.00-inch (76.2 mm) chain width as shown below.

Sprocket Locations

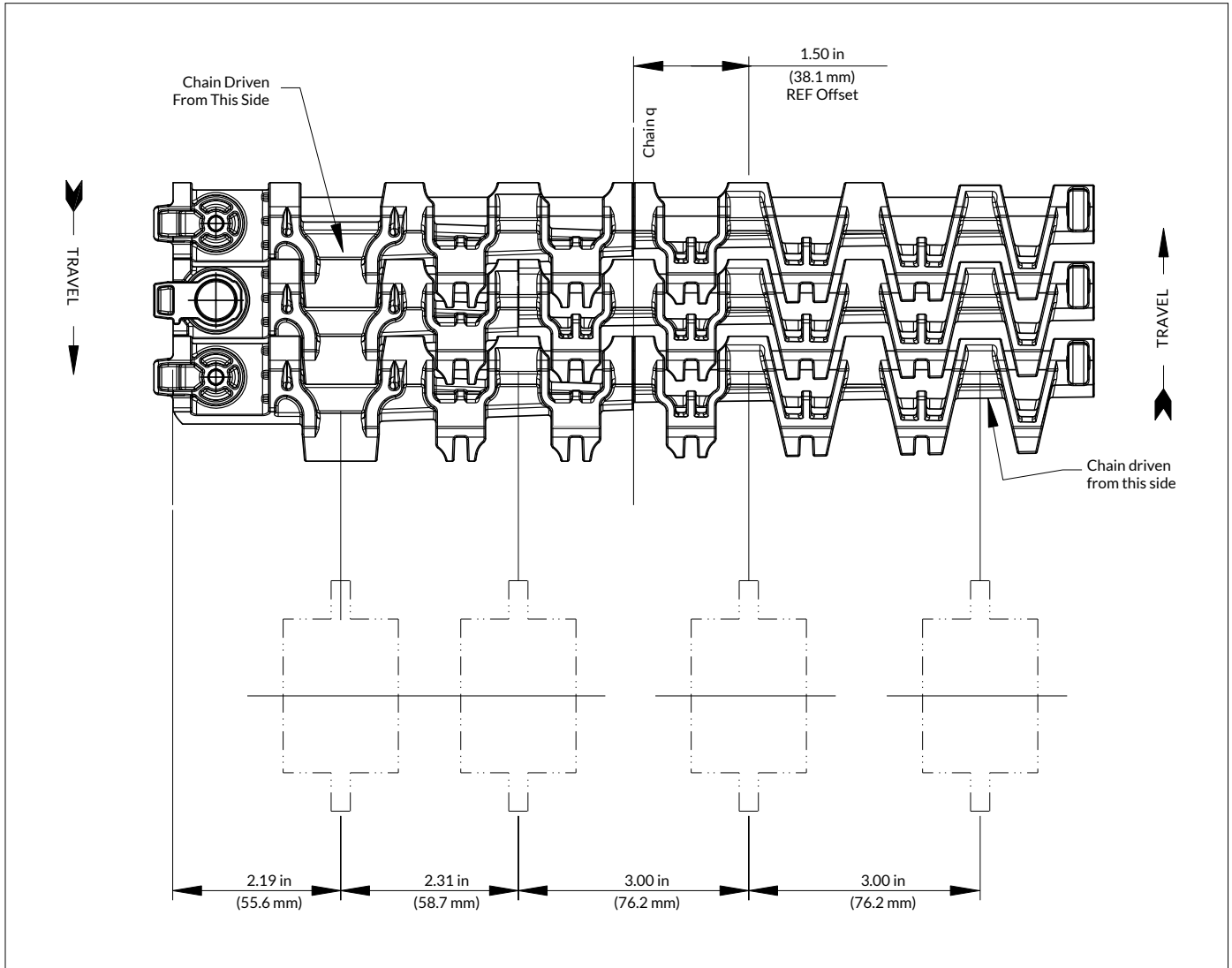

Note: 1-1/2-inch Sprocket offset from centerline of chain only necessary for 12-, 18-, 24-, 30 and 36-inch assemblies.

No sprocket/chain offset required for 15-, 21-, 27- and 33-inch chains.

8500 Series – Components

DYNAMIC NOSE-OVER BAR KITS

- Standard material for nose-over bar is nylon.
- For use with all 8500 MatTop Chain.
- Uses standard 5/16-inch or M8 flat head screws (not included).
- Multiple modular nose-over bars can be used side-by-side to obtain a variety of widths.

Dynamic Nose-Over Bar



Dynamic Nose-Over Bar

Style	Part Number	Overall Length	Hardware
Dynamic Nose-Over Bar Kit	10302910	3 in (76.2 mm)	None
Dynamic Nose-Over Bar Kit	10193110	6 in (152 mm)	None

KU8500-10T SPROCKET

Bores available to fit standard 3/4 to 1.00-inch and 25 mm shafting

KU8500-10T Sprocket



General Notes

- A polyester pin **MUST** be used for all nose-over applications – the polyester pin is a standard offering for most materials. If it is not a standard offering it should be specified when ordering. The only exception is TCF chains which should utilize the standard acetal pin.
- Small 0.75-inch (19.1 mm) pitch is ideal for handling small, unstable products.
- The minimum deadplate widths for 8500 Series MatTop Chain is shown on page 6.

8500 Series – Mounting Information

Center to Center Nose Bar Distance (A)

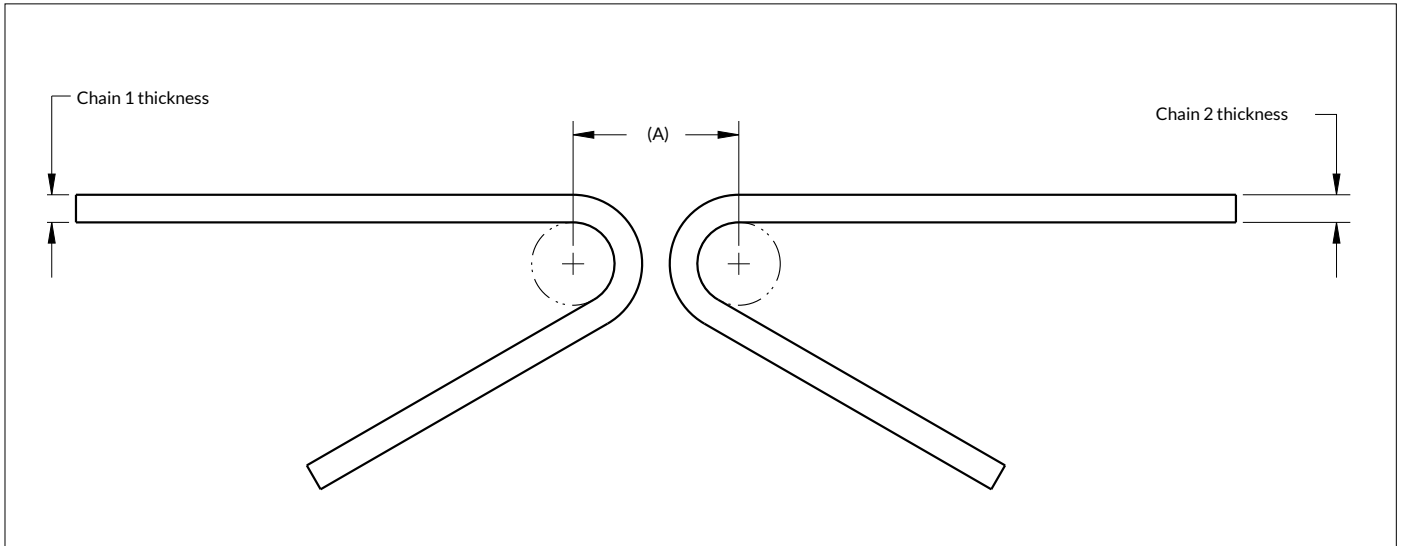

Center to Center Nose Bar Distance (A)

Chain 1		Chain 2		(A) Dimension
Chain Series	Chain Thickness	Chain Series	Chain Thickness	
8505/06	0.34 in (8.7 mm)	8505/06	0.34 in (8.6 mm)	2.06 in (52.3 mm)
8505/06	0.34 in (8.7 mm)	8505RT	0.44 in (11.2 mm)	2.13 in (54.1 mm)
8505/06	0.34 in (8.7 mm)	8503	0.43 in (10.9 mm)	2.17 in (55.2 mm)
8505RT	0.44 in (11.2 mm)	8505RT	0.44 in (11.2 mm)	2.09 in (53 mm)
8505RT	0.44 in (11.2 mm)	8503	0.43 in (10.9 mm)	2.19 in (55.5 mm)
8503	0.43 in (10.9 mm)	8503	0.43 in (10.9 mm)	2.29 in (58.1 mm)

8500 Series – Mounting Information

DYNAMIC NOSE-OVER BAR

- The optimum nose-over bar diameter is as follows:
 - 8500 = 1.125-inch (30 mm) diameter
- Uses standard 5/16-inch or M8 flat head screws for mounting (not included).
- Multiple modular nose-over bars can be used side-by-side to obtain a variety of widths; however, they cannot be cut to smaller widths.
- The dynamic nose-over bar is typically used in applications that handle difficult to convey products and/or high speeds. Make sure that the mounting plate does not interfere with the chain.

Dynamic Nose-Over Mounting (8500)

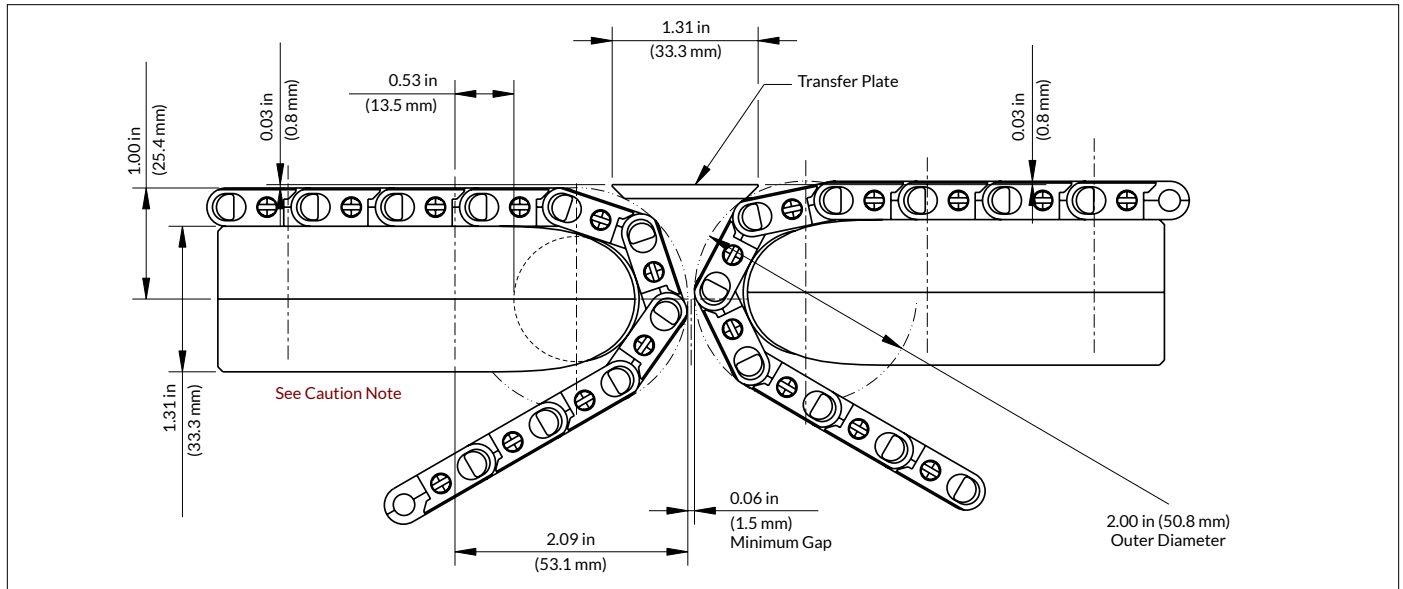

Dynamic Nose-Over Mounting (8500 RubberTop)

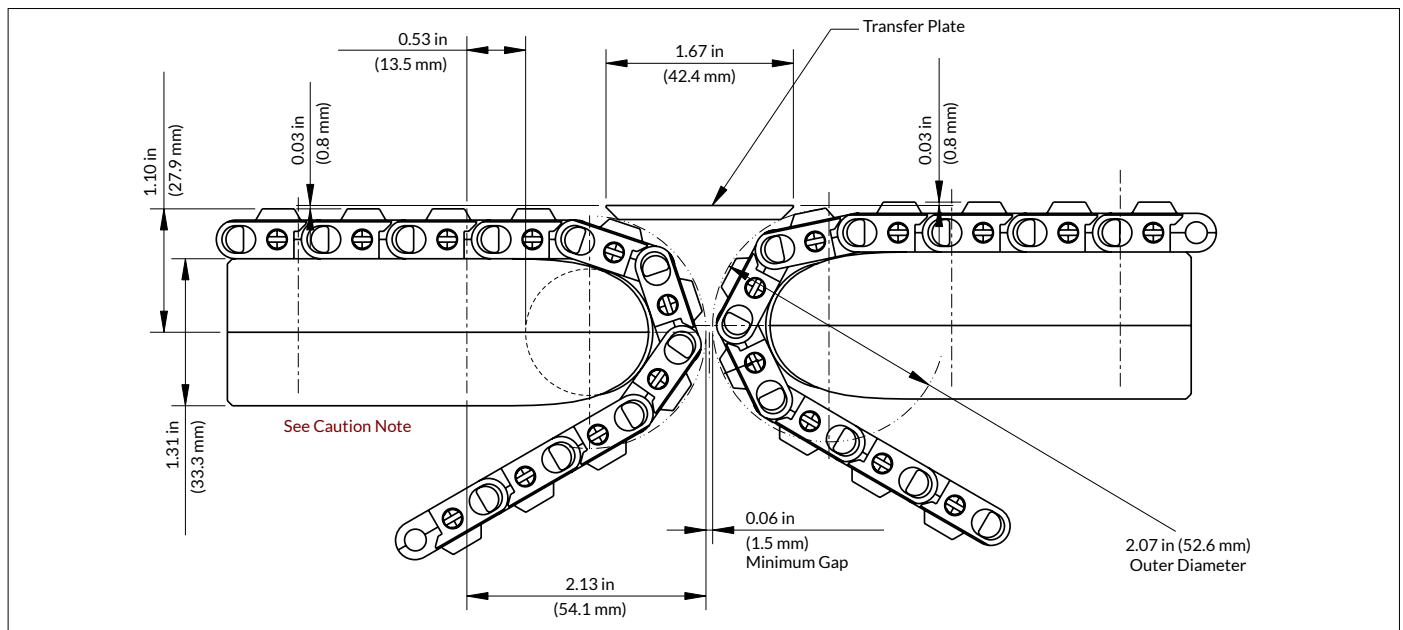

Make sure that the nose-over bar mounting plate does not interfere with the chain. The chain should be wrapped 135 - 150° around the nose-over.

8500 Series – Mounting Information

HEX SHAFT NOSE-OVER

The required hex shaft size: 0.94-inch (23.8 mm).

Hex Shaft Nose-Over Mounting (8500)

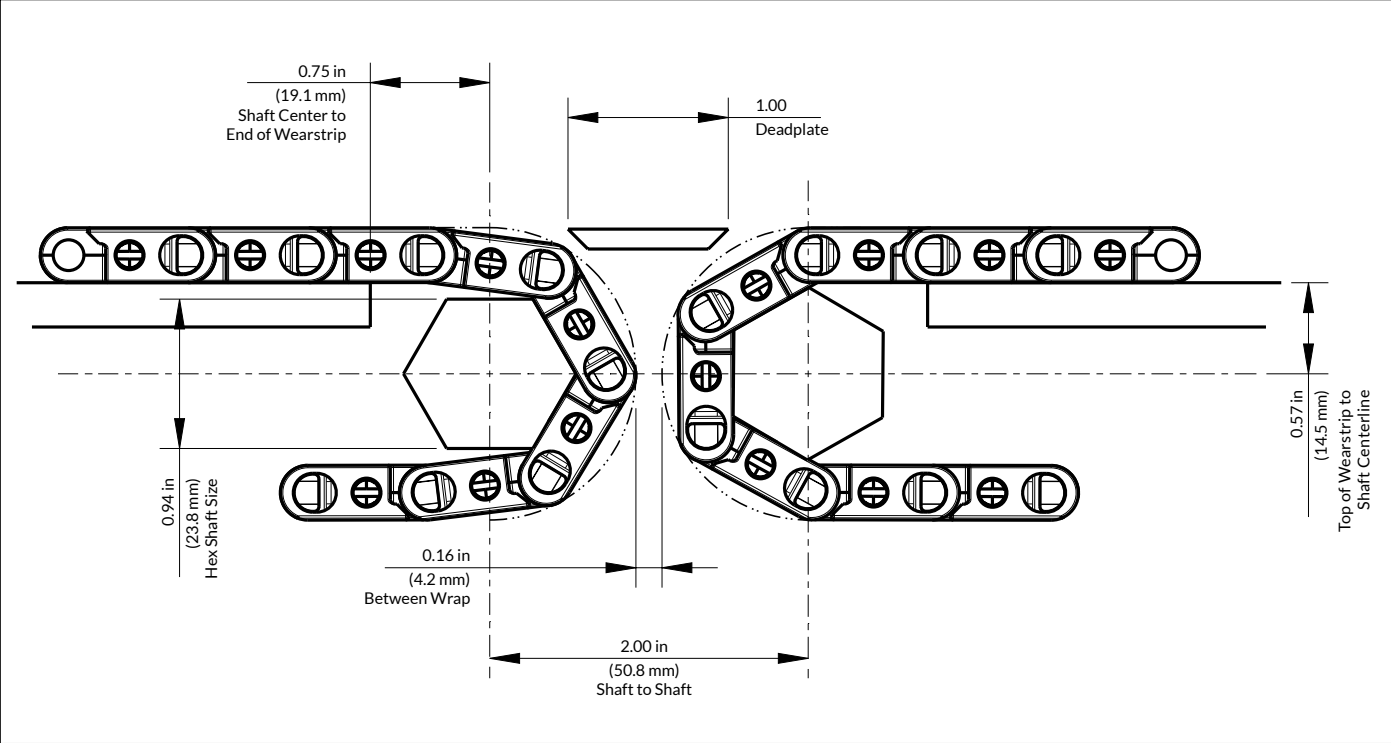

8500 Series – Mounting Information

DYNAMIC NOSE-OVER BAR

6" Dynamic Nose-Over Drawing

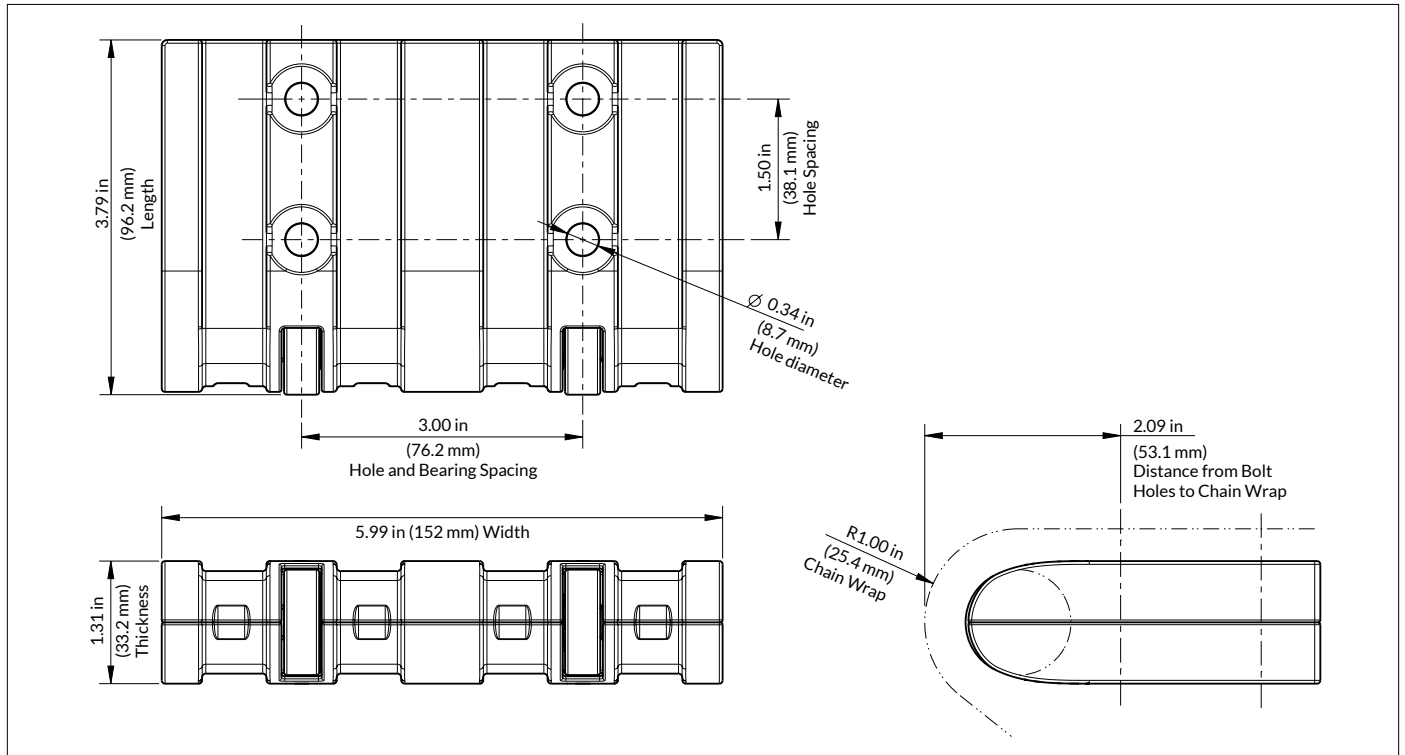

3" Dynamic Nose-Over Drawing

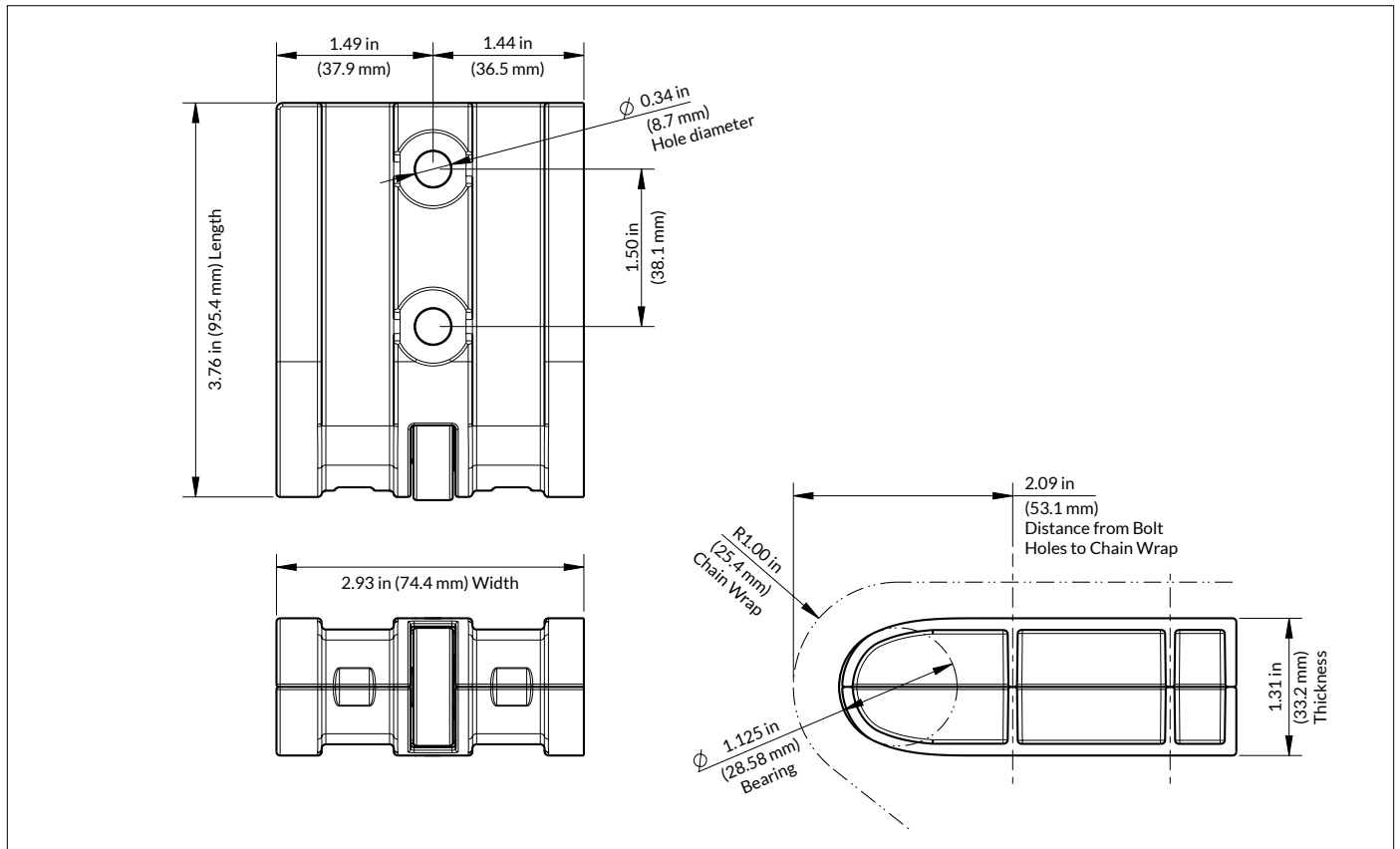

8500 Series – Sprocket Locations

SPROCKET LOCATIONS

8500 Sprocket Locations

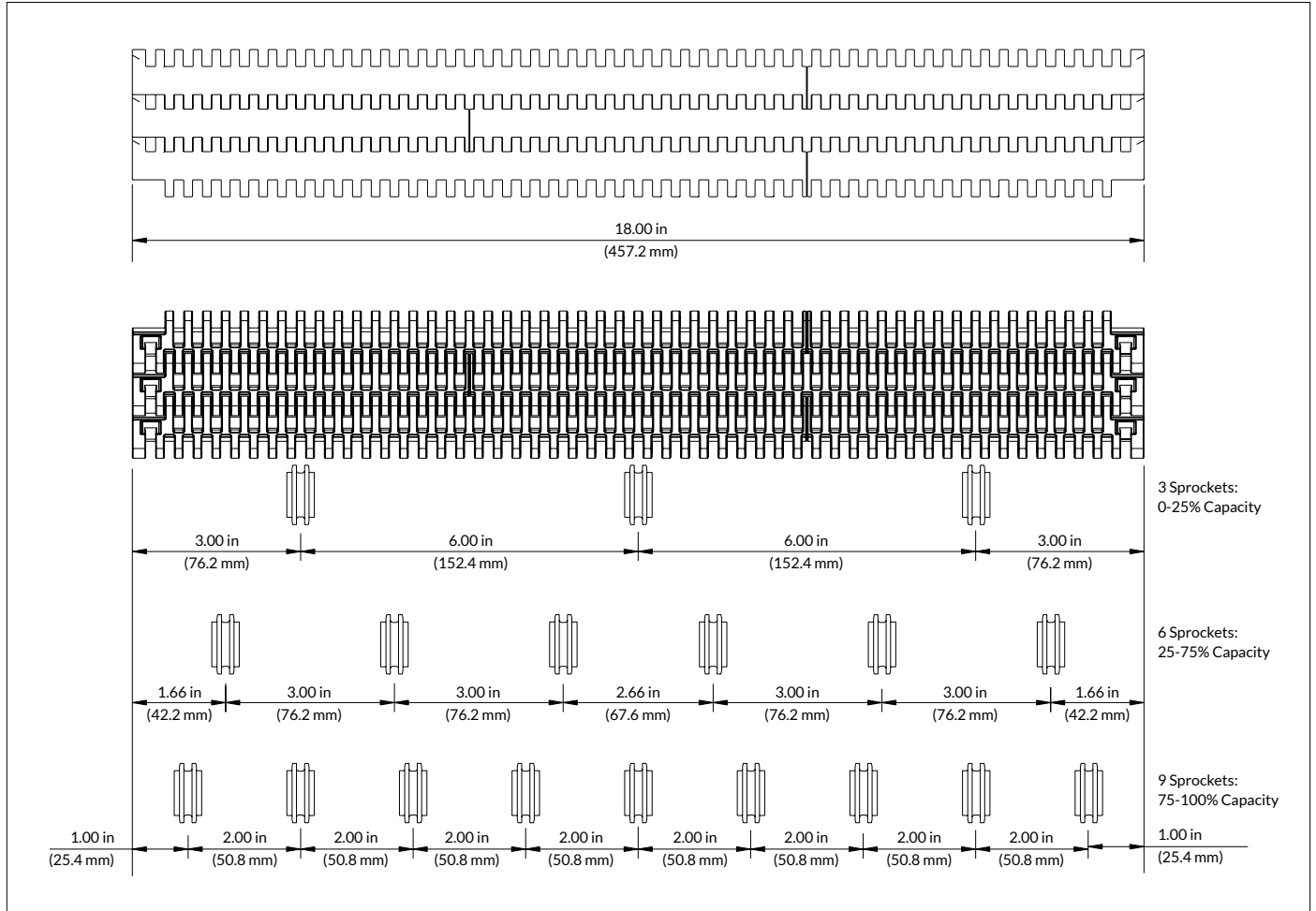

Drive Configurations

GENERAL RECOMMENDATIONS FOR NOSE-OVER CONFIGURATIONS

There are many different drive configurations that can be used for nose-over conveyors. The catenary or take-up arrangements will vary based on drive configurations. The following pages give a few examples that can be used for either uni-directional or bi-directional conveyors.

- The function of the catenary is to allow a place for excess chain to accumulate.
- Rexnord MatTop chains should never be run tight (reduces chain tension).
- The catenary sag should always be measured when running.
- If the catenary sag is excessive or increases due to wear, it should be adjusted by removing links to obtain the proper sag.
- Take-ups are typically not recommended; however, if a take-up must be used, a pneumatic type is preferred.
- The catenary sag should be located as close to the drive as possible.
- The minimum size roller should be 2.00-inch (50 mm) diameter; however, a larger roller is always recommended to decrease joint wear and extend the life of the chain.
- The lead-in shoe from the catenary sag to the return bed is recommended to have a 6.00-inch (150 mm) radius to ensure the chain does not over-backflex. It is always recommended to minimize back-flexing as this decreases joint wear and extends chain life (i.e. utilize lead in shoes with a generous radius). See the table below for the minimum back-flex radius for each chain series.
- The recommended wrap angle on nose-over bars is 135 - 180°.
- **Chain elongation is a concern with nose-over conveyor designs and a polyester pin MUST be used. The only exception is the TCF chains which should utilize the standard pin material.**

Minimum Back-Flex Radius per Chain Series

Chain Series	Minimum Back-Flex Radius
1500	1.00 in (25.4 mm)
7526	0.59 in (15.0 mm)
8500	1.00 in (25.4 mm)



The catenary sag area must be free of all obstructions, such as frame cross-members, supports and drive components that can damage chain or inhibit proper catenary sag.

Drive Configurations

GENERAL RECOMMENDATIONS FOR BI-DIRECTIONAL CONVEYOR

Drive Configuration for Bi-Directional Conveyor (Drawing is shown with 1500 Series MatTop Chain)

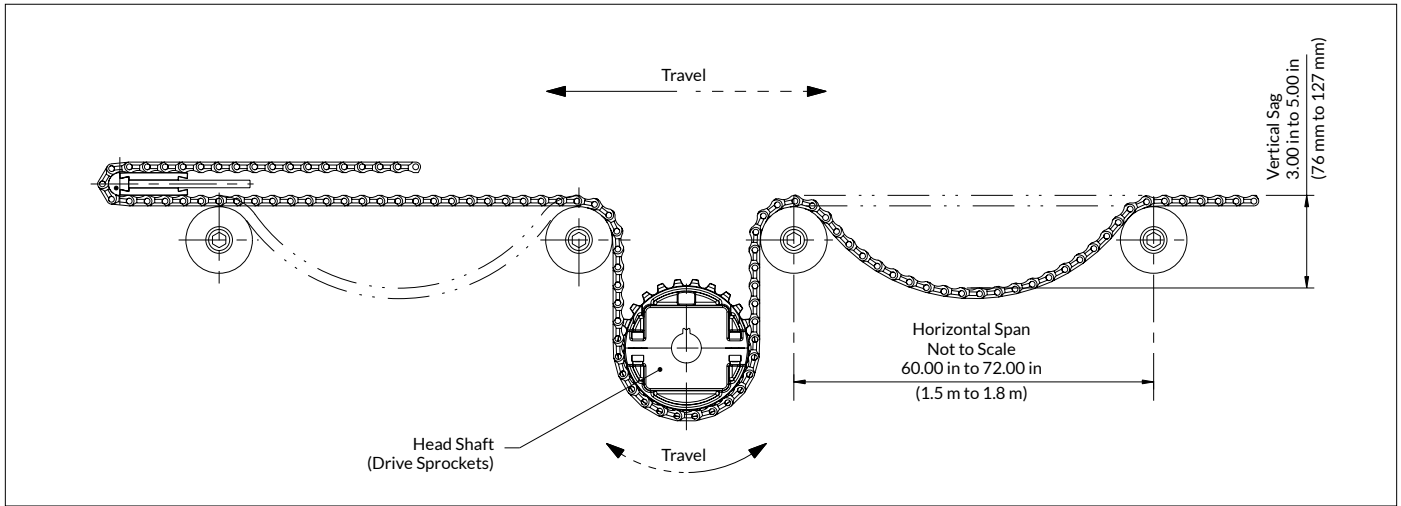

Bottom Drive Location (Drawing is shown with 1500 Series MatTop Chain)

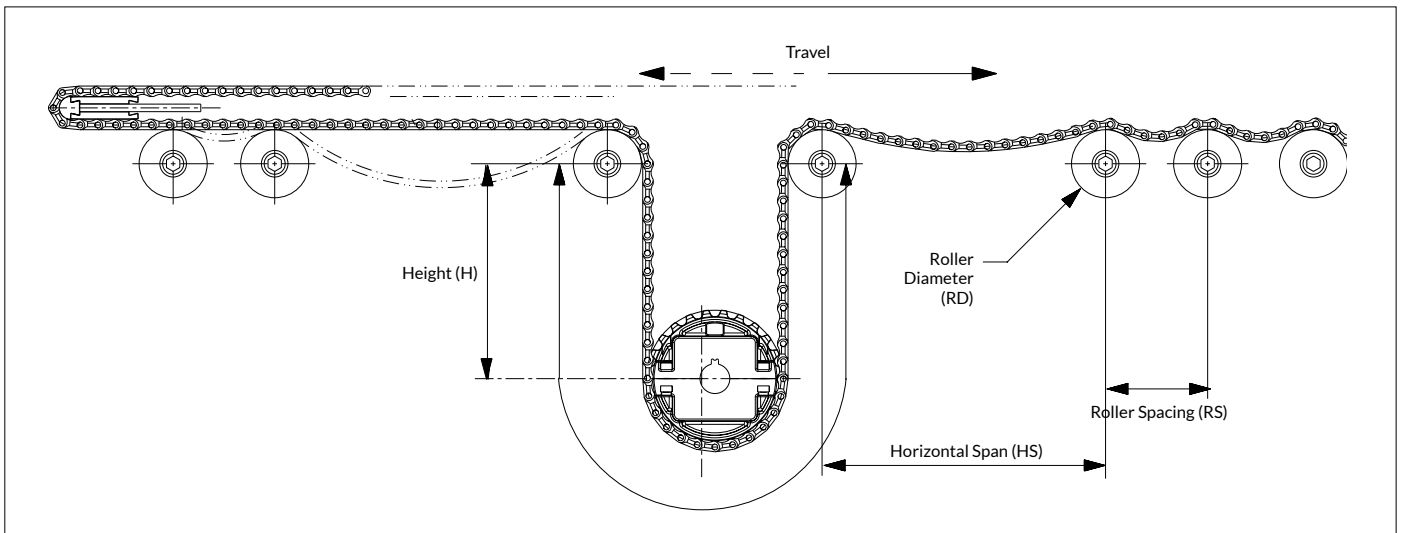

Make sure that all the units are the same when completing calculations.



The horizontal span of the catenary in a bi-directional, bottom drive conveyor is very critical. The horizontal span must be larger than the length of chain wrapped around the sprocket (L-dimension). If the horizontal span is not larger than the L-dimension, the catenary will form at the drive location and cause chain-sprocket engagement issues.

The following formulas provide general guidelines for designing bi-directional, bottom drive conveyors:

- $RD = 2 \times \text{back-flex radius (minimum)}$
- $PD = \text{Pitch Diameter}$
- $CP = \text{Chain Pitch}$
- $H \text{ (minimum)} = (PD + RD)/2 + CP$
- $L = 2 \times H + (PD \times 3.14)/2$
- $HS = 1.5 \times L \text{ (5 to 6 feet (1.5 to 1.8 m))}$
- $RS = HS / 2$

Drive Configurations

GENERAL RECOMMENDATIONS FOR UNI-DIRECTIONAL CONVEYOR

Concept A: Drive Configuration for Uni-Directional Conveyor (Drawing is shown with 1500 Series MatTop Chain)

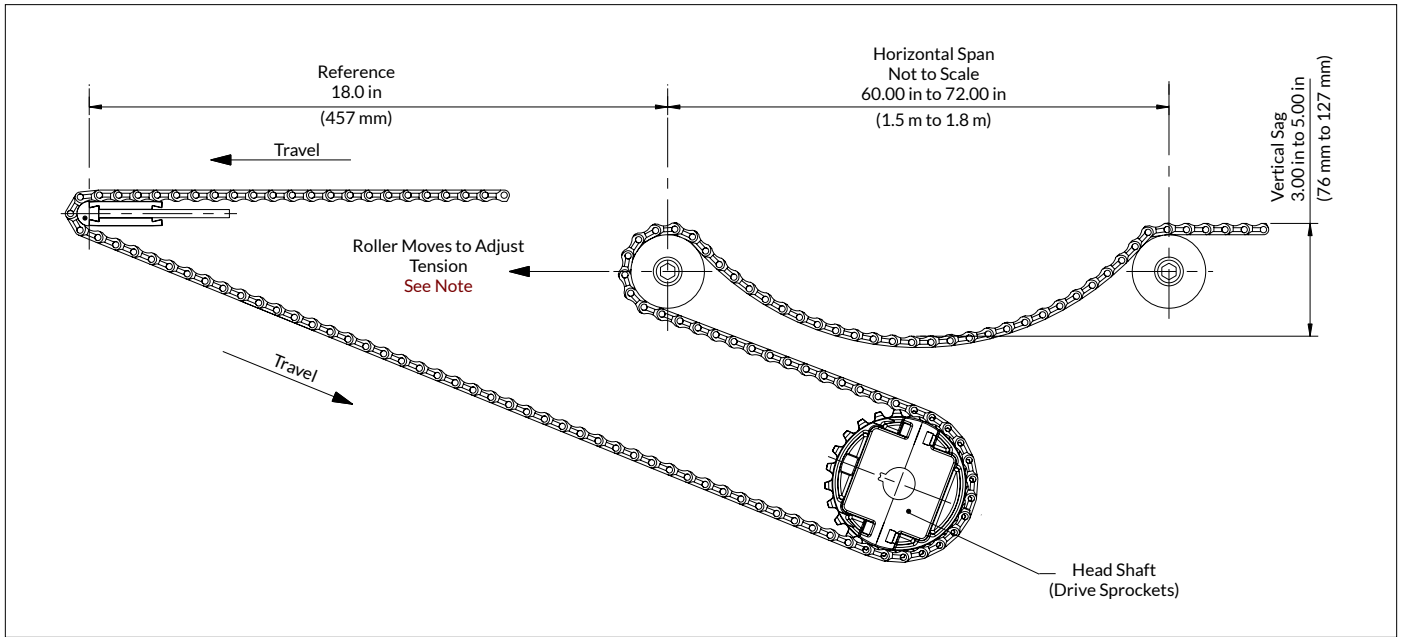

Note: The vertical catenary sag must be maintained by adjusting the roller to ensure sag does not interfere with chain leaving the drive sprocket.

Concept B: Drive Configuration for Uni-Directional Conveyor (Drawing is shown with 1500 Series MatTop Chain)

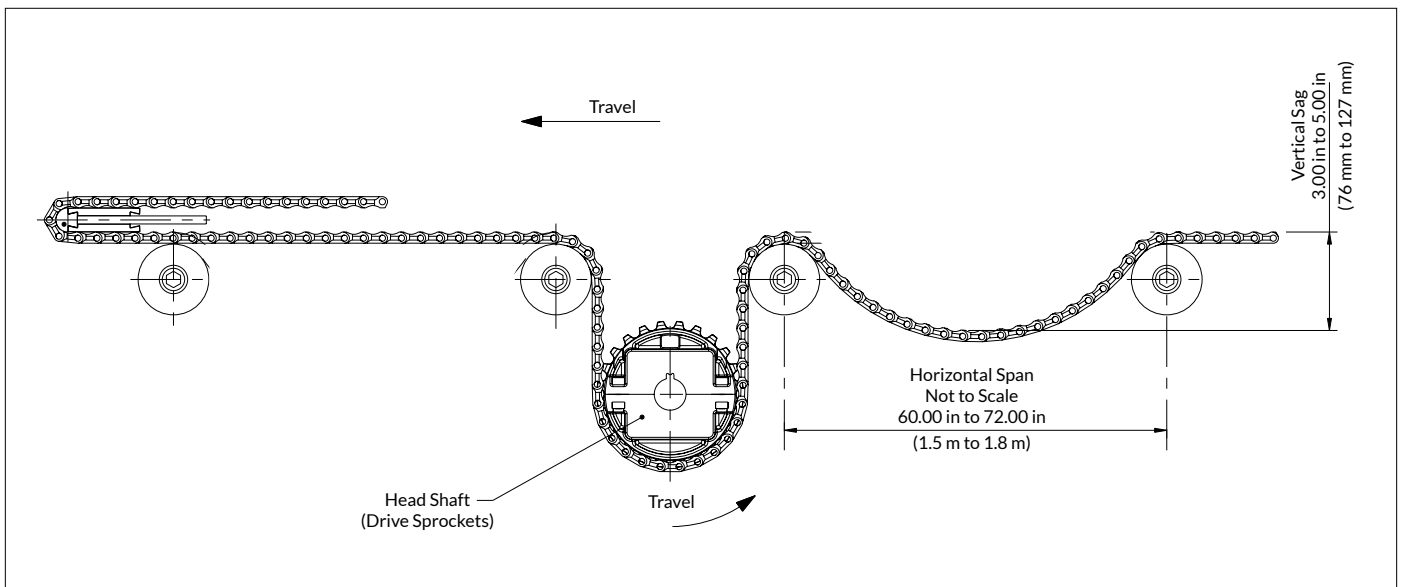

Drive Configurations

GENERAL RECOMMENDATIONS FOR UNI-DIRECTIONAL CONVEYOR

Concept C: Drive Configuration for Uni-Directional Conveyor

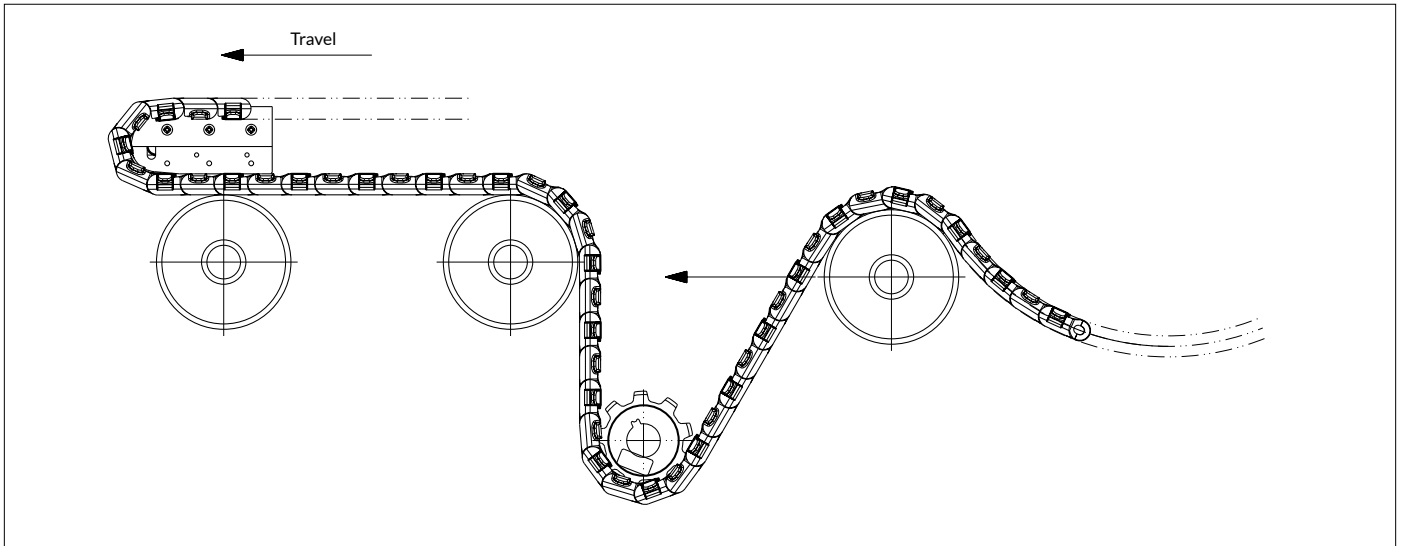

- The chain wrap around the sprocket must be between 150 - 180° to ensure proper chain-sprocket engagement.
- Refer to the formulas on [page 34](#) to properly locate the bottom drive (note refers to Concept A, B and C).

GENERAL RECOMMENDATIONS FOR UNI-DIRECTIONAL CONVEYOR WITH NO CATENARY

Drive Configuration for Uni-Directional Conveyor (Drawing is shown with 1500 Series MatTop Chain)

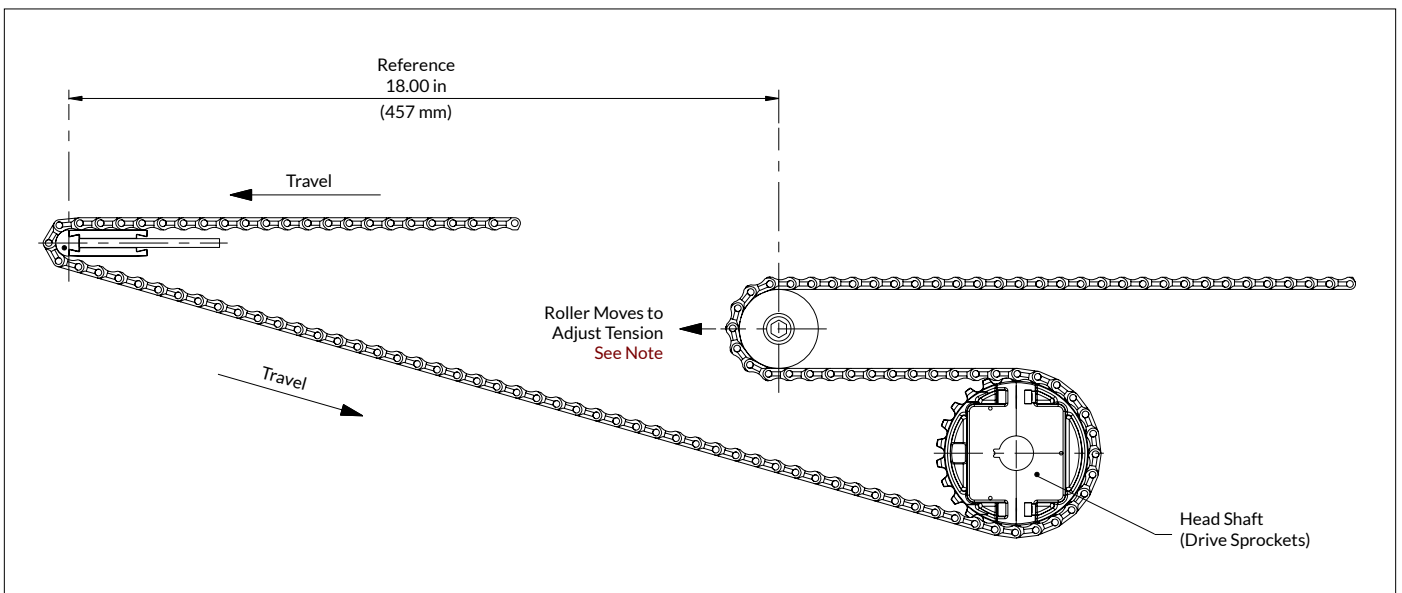

Carry and Return Ways

GENERAL RECOMMENDATIONS

- UHMWPE wearstrips are recommended.
- If required for improved performance, nylon wearstrips may be used in the corners (applies only to 7526).
- All sharp edges of wearstrips, and corner tracks, should be chamfered to ensure smooth chain movement. Recommended surface finish of wearstrips is 64 to 125 μ -in Ra (1.6 to 3.2 μ -m Ra) for best wear performance.
- Inside edges of straight and corner sections should contain a lead-in or chamfer for a smooth transition.
- If center wearstrips are required due to product loading, stagger them to distribute chain wear.
- Offset rail, serpentine and chevron patterns are recommended to maximize chain life because they provide uniform wear across the full width of the chain (details of wearstrip patterns can be found in the **Rexnord Engineering Manual** [[8rxEM-en](#)] in the Carry and Return Way section for MatTop chains).
- The wearstrips under each chain on horizontal conveyors must be level and even with each other.
- The MatTop Chain can be edge guided via solid edge-guides, guide blocks spaced every 2.00-feet (0.6 m) or L-shaped outside wearstrips. It is critical to allow proper clearance between edge of chain and conveyor frame for thermal expansion (refer to engineering manual for details).
- Return rollers should have a minimum of 2.00-inch (50.8 mm) diameter and spaced no more than 18.00-inch (450 mm) apart. However, a larger diameter is recommended to decrease joint wear.
- To provide proper catenary sag, the first roller spacing after the drive should be 1.5 times the spacing between all of the other rollers as shown below. The return chain can be edge-guided by the use of thin collars or flanges at the outer edges of the rollers.

Roller Return Configuration

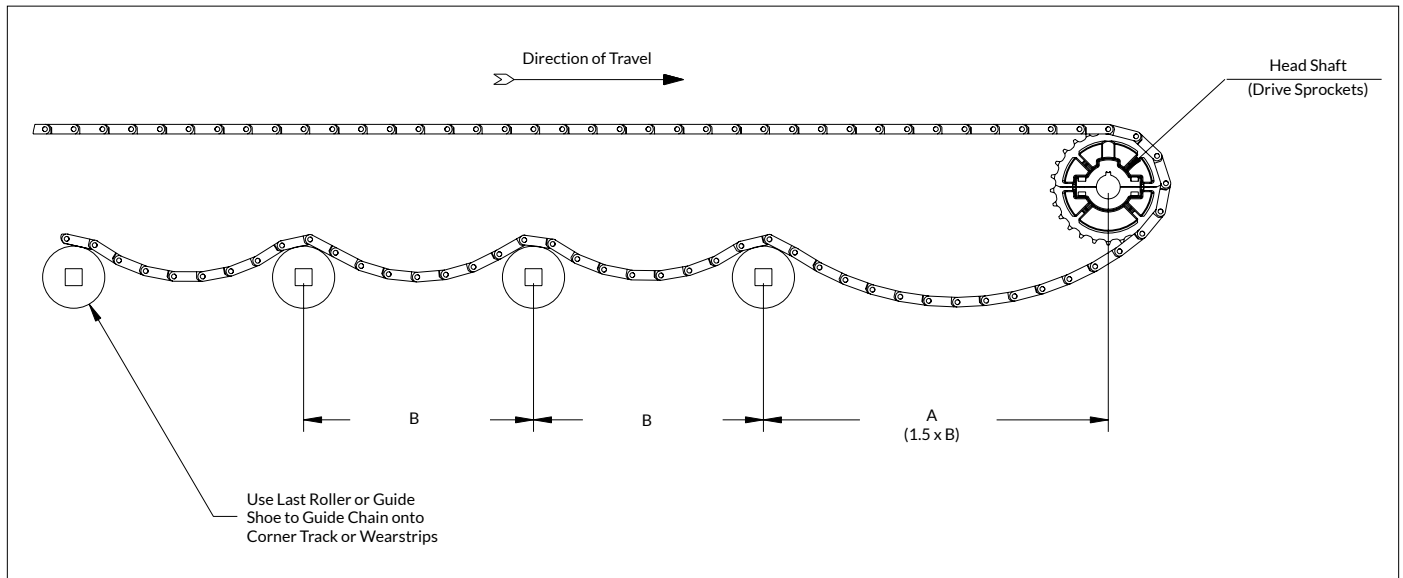

High-Speed Applications

GENERAL RECOMMENDATIONS

The following table gives general guidelines when selecting a nose-over transfer style depending on the speed of the application. These are general recommendations and are based on the assumption that the chain tension is within capacity.

- For obtaining optimum chain life, it is recommended to specify chains with polyester pins for all nose-over applications. This is especially critical for high speed applications. The only exception is TCF chains which should utilize the standard pin material.
- It is recommended to use the maximum wrap angle for high speed applications to obtain as much surface contact as possible, avoiding PV-type failures.
- Noise, vibration and excessive wear are more prevalent on high speed conveyors. For applications in which these issues are critical it is recommended to use a small sprocket.

Recommended Nose-Over Type

Speed		Chain Material		
Feet per minute (FPM)	Meters per minute (MPM)	HP™ / PS®	TCF	HT / HTF / KHT
less than 150	less than 45	Lubricated nylon	UHMWPE*	Lubricated nylon*
		Small sprocket	Small sprocket	Small sprocket
150 to 300	45 to 90	Lubricated nylon	Dynamic	Dynamic
		Small sprocket	Small sprocket	Small sprocket
over 300	over 90	Dynamic**	Dynamic**	Dynamic**
		Small sprocket***	Small sprocket***	Small sprocket***

* The maximum speed of HTF/TCF1505 and HTF8505 chains is 150 FPM (45 mpm) based on a maximum load of 80 lbs/ft (119 kg/m). When using TCF1505 chains on UHMWPE nose-over bars, normally the UHMWPE nose-over bars will wear faster than the chain. UHMWPE nose-over bars are available on a MTO basis. When using TCF1505 chains on lubricated nylon nose-over bars, normally the chain will wear faster than the nose-over bars.

** The dynamic nose-over bar option can be utilized for any speed if the chain is within capacity for the specific application

*** Consult Application Engineering for high speed applications in which a small sprocket may be an option (or utilize the Calculation Program to determine if the bore size limitations are appropriate for the specific loading)

Unstable Product Transfer Applications and Adjustability

GENERAL RECOMMENDATIONS FOR UNSTABLE PRODUCTS

- Normal component wear may cause instability issues or product tippage problems for products that are difficult to convey. It is recommended to use the dynamic nose-over bar option for these applications.
- Contact Application Engineering to discuss options or to perform a product handling test.

GENERAL RECOMMENDATIONS FOR ADJUSTABILITY

- Normal component wear may cause instability issues or All components will wear with time (adjustments to the nose-over bar and/or transfer plate may be required to maintain smooth product transfer throughout the life of the conveyor).
- Due to the wear on the components, it is recommended to design an adjustable deadplate between head and tail ends.
- Rexnord recommends a minimum deadplate adjustability between head and tail nose-over bar to be 0.13-inch (3.2 mm) in both the horizontal and vertical plane with a +/- 10° rotation.
- To further ensure smooth transfers due to wear, it is recommended to design adjustment capabilities into the nose-over bar support structure.
- Since the static nose-over bar (1500 Series only) is considered the replaceable wear element it is recommended to design an opening or access area in the conveyor frame to ensure that the nose-over bar can easily be replaced (see page 15). This allows the nose-over bar to be replaced without having to disassemble the chain, which reduces maintenance.