



Falk Ultramite 300UJ Series Shaft-Mounted Offset Helical Gear Drives (Inch)



Falk Ultramite 300UJ Series Shaft-Mounted Offset Helical Gear Drives



To learn more about the Falk® Ultramite® 300UJ
and the rest of the Falk Ultramite family of products,
go to www.rexnord.com, where you'll find:

Product information • Brochures • Catalogs • Manuals

866-REXNORD/866-739-6673 (toll-free within the U.S.) or +1 414-643-2366 (Outside the U.S.)



Table Of Contents

DESCRIPTION	PAGE
Falk Ultramite Basic Information	4
Conditions Affecting Selections	5
300UJ — How to Select and Order Gearmotors	6
300UJ — How to Select and Order Gear Drives	7
300UJ — Drive Nomenclature	8
Service Factors	9
300UJ — Exact Ratios	11
300UJ — Drive Mounting Position	12
300UJ — Motor Adapters	13
Motor Detail (NEMA C-Face)	14
GEARMOTORS	
300UJ — Gearmotor Selection Table	15
300UJ — Double & Triple Reduction Gearmotor/Straight Hollow Dimenstions	32
300UJ — Quadruple & Quintuple Reduction Gearmotor/Straight Hollow Dimenstions	33
300UJ — Double & Triple Reduction Gearmotor/Hollow Shaft with TA Taper Bushing Dimenstions	34
300UJ — Quadruple & Quintuple Reduction Gearmotor/Hollow Shaft with TA Taper Bushing Dimenstions	35
300UJ — Double & Triple Reduction Gearmotor/Inch Single-Ended Dimenstions	36
300UJ — Quadruple & Quintuple Reduction Gearmotor/Inch Single-Ended Dimenstions	37
300UJ — Double & Triple Reduction Gearmotor/Hollow Shaft with Shrink Disc Dimenstions	38
300UJ — Quadruple & Quintuple Reduction Gearmotor/Hollow Shaft with Shrink Disc Dimenstions	39
300UJ — Shaft-Mounted Gearmotor and Gear Drive/TA Taper Bushing — Inch	40
300UJ — Shaft-Mounted Gearmotor and Gear Drive/TA Taper Bushing — Metric	41
TECHNICAL DATA — GEARMOTORS & GEAR DRIVES	
300UJ — Overhung Loads	42
300UJ — Gear Drive LSS Overhung Load Ratings	43
GEAR DRIVES	
300UJ — Gear Drive Horsepower and Torque Ratings	51
300UJ — Gear Drive Thermal Horsepower Ratings	59
300UJ — Double & Triple Reduction Gear Drive/Straight Hollow Shaft Dimenstions	60
300UJ — Quadruple & Quintuple Reduction Gear Drive/Straight Hollow Shaft Dimenstions	61
300UJ — Double & Triple Reduction Gear Drive/Hollow Shaft with TA Taper Bushing Dimenstions	62
300UJ — Quadruple & Quintuple Reduction Gear Drive/Hollow Shaft with TA Taper Bushing Dimenstions	63
300UJ — Double & Triple Reduction Gear Drive/Inch Single-Ended Dimenstions	64
300UJ — Quadruple & Quintuple Reduction Gear Drive/Inch Single-Ended Dimenstions	65
300UJ — Double & Triple Reduction Gear Drive/Hollow Shaft with Shrink Disc Dimenstions	66
300UJ — Quadruple & Quintuple Reduction Gear Drive/Hollow Shaft with Shrink Disc Dimenstions	67
ACCESSORIES AND SHIPPING WEIGHTS	
300UJ — Screw Conveyor Gearmotor and Gear Drive	68
300UJ — Hollow Low Speed Shaft Dimensions and Recommendations	70
300UJ — Customer Shaft Recommendations: Dimensions for Largest for TA Taper Bore Bushings	71
300UJ — Shrink Disc Shaft Dimensions and Recommendations	72
300UJ — B5 Output Flange	73
300UJ — B14 Output Flange	74
300UJ — Torque Arm	75
300UJ — WR ²	77
300UJ — Approximate Shipping Weights	78

Falk Ultramite Basic Information

Safety Notes

Falk Gear Drives — The Falk and Rexnord name on the gear drive is the purchaser's assurance that the drive was engineered, rated and manufactured to sound design practices.

The power supplied to the geared drive must be equal to or less than the power for which the drive was selected using the appropriate service factor for the application. The customer must also assume the responsibility of isolating the geared drive from any vibratory or transient load induced by the driven equipment.

Install and operate Rexnord products in conformance with applicable local and national safety codes and per Rexnord installation manuals which are shipped with gear drives and are also available upon request. Suitable guards for rotating members may be purchased from Rexnord as optional accessories. Consult your local Rexnord Representative for complete details.

People Conveying Equipment — Selection of Rexnord gear drives for applications whose primary purpose is the transportation of people is not approved. This includes such applications as freight or passenger elevators, escalators, man lifts, work-lift platforms, and ski tows and ski lifts.

If the primary purpose of the application is material conveyance and occasionally people are transported, the Rexnord warranty may remain in effect, provided the design and load conditions are not exceeded and certification to the appropriate safety codes and load conditions has been obtained by the system designer or end user from the appropriate enforcement authorities.

Gear Drive Ratings

All gear drive ratings in this catalog allow 100% overload for starting loads and momentary overloads for electric-motor-driven applications operating ten hours per day under uniform conditions. For other conditions, compute an equivalent horsepower by multiplying the actual horsepower required for the application by the appropriate service factor.

Gear Drive Identification — Tables in this catalog identify gear drives based on the drive nomenclature.

Horsepower & Torque/Gearmotor Drives — Gearmotor drive mechanical horsepower and delivered torque ratings are tabulated only at 1750 rpm. Horsepower, output torque and LSS OHL ratings for gearmotor drives do not always correspond to those of the comparable inline gear drive of the same size, reduction and ratio. In selected cases the gearmotor drive will have more rating than the corresponding inline gear drive. When additional rating for gearmotor drives at 1750 rpm input is available, it will be as stated in the Gearmotor Selection Tables. For gearmotor drive ratings at input speeds other than 1750 rpm, consult the Factory.

Horsepower & Torque/Gear Drives — Gear drive mechanical horsepower and output torque ratings are tabulated in the catalog to permit selections for specific application requirements. When the required input speed falls between two tabulated input speeds of a specific drive designation (size, reduction and ratio), interpolate to determine drive rating.

Lubricants — Drive Sizes 302, 304, 306 & 307UJ will be supplied filled with a quantity of EP mineral oil suitable for the drive mounting position specified at the time of the order.

Drive Sizes 308, 309, 310 & 312UJ are supplied without lubricant. The appropriate fill quantities and lubricant recommendations are stated in Manual GR3-016 for UJ drives.

Stored & Inactive Gear Drives — Each gear drive is protected with rust preventive that will protect parts against rust for a period of 6 months in an indoor dry shelter.

Sizes 308 thru 312UJ — If a gear drive is to be stored, or is inactive after installation beyond the above periods, drain oil from housing and spray all internal parts with a rust preventive oil that is soluble in lubricating oil or add Motorstor™ vapor phase rust inhibitor at the rate of one ounce per cubic foot of internal drive space (or 5% of sump capacity) and rotate the shafts several times by hand. Before operating, drives which have been stored or inactive must be filled to the proper level with oil meeting the specifications given in Manual GR3-016 for UJ drives. Refer to Manual 128-014 for "Start-up after Storage" instructions.

Periodically inspect stored or inactive gear drives and spray or add rust inhibitor every six months, or more often if necessary. Indoor dry storage is recommended.

Gear drives ordered for extended storage can be treated at the Factory with a special preservative and sealed to rust-proof parts for periods longer than those cited previously.

Factory Warranty — Falk products generally carry a limited, three-year warranty against defects in materials or workmanship; but for an actual statement of the Factory Warranty, ask your local Rexnord representative or Falk/Rexnord distributor for our Standard Conditions of Sale.



Conditions Affecting Selections

Non-Standard Application Procedures

The following conditions may affect the gear drive selection procedure, drive size and auxiliary equipment being furnished.

Excessive Overloads — The maximum momentary or starting load must not exceed 200% of rated load (100% overload). Rated load is defined as gear drive rating with a service factor of 1.0. If the maximum starting or momentary load exceeds the above conditions, compute a second equivalent horsepower by dividing the peak load by two. The gear drive selected must have capacity equal to, or in excess of, the larger equivalent horsepower.

Reversing Service — Applications involving either more than 20 reversals per ten hour period, or less than 20 reversals per ten hour period with peak torques greater than 200% of normal load must be referred to Factory.

Stop and Start Service — Applications involving frequent stop and start overloads in excess of ten times per day must be referred to Factory.

Brake-Equipped Applications — When a gear drive is equipped with a “working” brake that is used to decelerate the motion of the system and the brake is located between the prime mover and the gear drive or on the rear of the motor, select the drive based on the brake rating or the highest equivalent horsepower, whichever is greater. If the brake is used for holding only and is applied after the motion of the system has come to rest, the brake rating must be less than 200% of the catalog rating, refer the application to Factory. Also refer to Factory all applications in which the brake is located on the output shaft of the gear drive.

Oversize Prime Mover — Published service factors do not cover applications that require oversize prime movers for high-energy or peak loads. Refer such applications to Factory for selection of suitable drives.

Speed Variation — Gear drives offered in this catalog are designed to operate with splash lubrication at all speeds for which they are cataloged, provided the appropriate amount of lubricant is present based on the drive mounting position. (Refer to Manual GR3-016 for UJ drives for oil quantity associated with each gear drive mounting position.) Variation of speed between cataloged speeds, or at speeds falling between cataloged speeds, is permissible.

Lubrication of Sizes 302, 304, 306 & 307UJ — These sizes are furnished filled with a quantity of oil. Quantity of oil furnished is based on the customer-identified drive mounting position stated at the time of order. Standard drive mounting positions are shown in this catalog. These sizes have no oil fill plug, oil drain plug or vent plug. Standard oil furnished with the gear drive is a petroleum-based, extreme pressure lubricant, conforming to AGMA Viscosity Grade 6EP, ISO Viscosity Grade 320, and no further lubrication of the gear drive is required.

Lubrication of Sizes 308 thru 312UJ — These sizes are furnished without oil. Customer oil fill is required. They are furnished with oil fill plug, oil drain plug and vent plug. Lubricant quantity lubricant specifications, location of plugs and recommended oil change frequency are stated in the Installation & Maintenance Guide GR3-016 for UJ drives.

Variable or Multi-Speed Applications — All Types

When selecting gear drives for multi-speed or variable speed application, determine the speed which develops the greatest torque and select the drive on this basis. If the speed is not listed in the selection table, use the next lower speed.

Effects of Solar Energy — If a drive operates in the sun at ambient temperatures over 100°F, then special measures must be taken to protect the drive from solar energy. This protection can consist of a canopy over the drive or reflective paint on the drive. If neither is possible, a heat exchanger or other cooling device may be required.

Overhung Loads & Thrust Loads — The overhung load and thrust load ratings published in this catalog are based on a combination of the most unfavorable conditions of rotation, speed, direction of applied load and drive loading. If the calculated load exceeds the published value, or if an overhung load and thrust load are applied simultaneously to a shaft, refer complete application information to Factory.

Non-Standard Mounting Positions — For non-standard mounting positions (other than those shown in this catalog) refer to Factory for lubricant level and quantity.

Double Seal Option — Certain applications may dictate the use of double seals. This option, provided at an additional charge, is furnished as follows:

Gearmotors — A double seal is available only at the low-speed shaft.

Inline Drives — A double seal is furnished at both the high-speed and low-speed shafts.

General Information

- Rexnord standards apply unless otherwise specified.
- All dimensions are for reference only and are subject to change without notice unless certified.
- H.S. Shaft or HSS = High-Speed Shaft.
- L.S. Shaft or LSS = Low-Speed Shaft.

Reference Notes

- Dimensions are for reference only and will vary with motor manufacturer.
- For higher ratio selections, consult the Factory.
- Check thermal input hp ratings. Selection tables are based on mechanical input hp ratings only.
- For L.S. Shaft Thrust Loads, consult the Factory.

300UJ — How to Select and Order Gearmotors

NOTE: Before making any selections, refer to the Falk Ultramite Basic Information and Conditions Affecting Selections on pages 4 and 5.

Selection of Shaft-Mounted Gearmotors

1. Determine Service Factor — See pages 9 and 10.
2. Determine Motor Horsepower.
3. Determine Gearmotor Output Speed and Ratio.
4. Gearmotor Selection Tables are included on pages 15-33. These tables assume a motor base speed of 1750 rpm. For ratings at other motor base speeds, consult your authorized Rexnord sales representative.

Go to the page that contains selections based on the specific C-face motor you will be using. For example, selections for 0.50 hp, 1750 rpm, 56C frame motors are tabulated on page 17.

Starting at the top of the first selection page pertinent to your motor requirement, move down the selections until a gearmotor meeting your output speed, ratio, reduction and service factor requirements is located.

For example consider an application with a 1 hp, 1750 rpm/143TC frame motor, output speed of 42 rpm, nominal ratio of 40:1, and a required service factor of 1.25.

Selections for a 1 hp, 1750 rpm/143TC frame motor are on page 19.

The gearmotor 302UJAQ2A40.A_B has an output speed of 45 rpm, exact ratio of 41.65:1 and a service factor of 1.36 which meets our requirements.

Choose your required accessories and record the full nomenclature and part number.

5. Check Overhung Load — Permissible low-speed shaft overhung load capacities are provided on pages 43-50. If overhung load is present, calculate the value of the overhung load per instructions on page 42. Sprockets or other devices mounted on the output shaft of the gearmotor should be sized and positioned so the gearmotor overhung load capacities are not exceeded. Should applied overhung loads exceed the capacity of the initial gearmotor selected, a larger gearmotor of adequate capacity must be selected.
6. Check Gearmotor Dimensions — pages 32-39.
7. When ordering, provide the gear drive mounting position from page 12. If a mounted motor is ordered, specify motor mounting position, also from page 12.

Example

Application: Belt conveyor, heavy-duty, head shaft speed is 22 rpm, shaft mounted drive configuration is specified.

Duty Cycle: 16 hours per day.

Driver: 10 hp electric motor, 1750 rpm, 215TC frame.

Output: Head shaft diameter is 2.75". Approximate ratio required is 80:1.

1. Service factor from page 10 is 1.50.
2. Motor horsepower is 10 hp.
3. From selection table on page 25, the appropriate gearmotor is the Size 309UJAQ3A80.A_D, exact ratio 79.38:1 and a 1.70 service factor.
4. Check overhung load capacity on page 43 — For this example there is no overhung load.
5. Check dimensions on pages 32-39.
6. Specify drive mounting position and motor mounting position (if mounted motor is requested) from page 12 — For our example, the gearmotor is mounted in drive mounting position #1.

Regarding mounting of NEMA C-face motors, the most common motor mounting position is "C", with the nameplate upward and the conduit box wiring hole down.

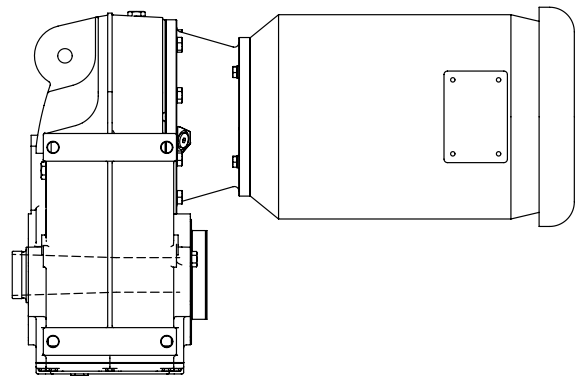

300UJ — How to Select and Order Gear Drives

NOTE: Before making any selections, refer to the Falk Ultramite Basic Information and Conditions Affecting Selections on pages 4 and 5.

Selection of Shaft-Mounted Gear Drives

1. Determine Service Factor — See pages 9 and 10.
2. Determine Equivalent Horsepower — Calculate the equivalent hp by multiplying the motor hp by the service factor.
3. Determine Gear Drive Output Speed and Ratio.
4. Gear Drive Selection tables are included on pages 51-58.

Go to the page that contains selections based on your required input speed for the gear drive. For example, selections based an input speed of 1750 rpm are shown on pages 51 and 52.

Locate the table containing your required ratio, reduction and low-speed shaft rpm and select the drive size with a mechanical rating equal to or exceeding your equivalent horsepower requirement.

5. Check Overhung Load — Tables on pages 43-50 provide the overhung capacity of the gear drive selected. If overhung load is present, calculate the value of the overhung load per instructions on page 42. Sprockets or other devices mounted on the input or output shaft of the gear drive, should be sized and positioned so the overhung load capacities are not exceeded. If applied overhung loads exceed the capacity of the initial gear drive selected, a larger gear drive of adequate capacity must be selected.
6. Check Gear Drive Dimensions — pages 60-67 and 73-74.
7. When ordering, provide the drive mounting position from page 12.

Example

Application: Belt conveyor, heavy-duty, head shaft speed is approximately 30 rpm, gear drive to be base-foot-mounted.

Duty Cycle: 16 hours per day.

Driver: 2 hp electric motor, 1750 rpm.

1. Service factor from page 10 is 1.50.
2. Equivalent horsepower is $2 \times 1.5 = 3$ hp.
3. Approximate gear drive ratio is 58:1.
4. From selection table on page 51, the appropriate gear drive exceeding required equivalent hp of 3 hp is the Size 306UJ with a rating of 3.47 hp and a service factor of 1.7 ($3.47 \text{ hp} \div 2 \text{ hp}$). Complete designation of the gear drive is obtained from page 51 and is 306UJQA2A56.N_, exact ratio 60.18:1.
5. Overhung load capacity on page 43 — For this example there is no overhung load.
6. Check dimensions on pages 60-67.
7. Specify gear drive mounting position from page 12 — For our example, the gear drive is mounted in mounting position #1.

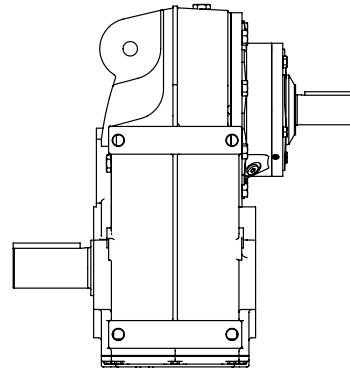

300UJ — Drive Nomenclature

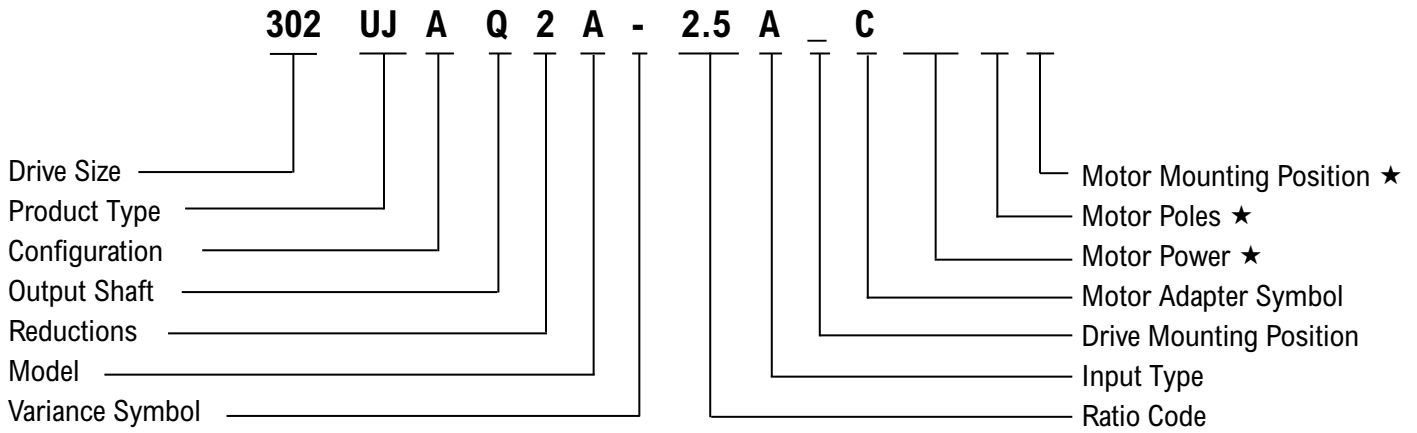

Drive Sizes

302, 304, 306, 307, 308, 309, 310, 312

Product Type

UJ — Shaft-Mounted Offset Helical

Configuration

A — Basic Drive

F — Standard Output Flange (B5)

G — Reduced Diameter Output Flange (B14)

R — Basic Drive with Torque Arm

Output Shaft

Q — Straight Inch Hollow

E — Straight Metric Hollow

J — Taper Hollow

M — TA Taper Metric Bushing

N — TA Taper Inch Bushing

P — CEMA Seal Housing

K — Inch Single Ended

L — Metric Single Ended

R — Hollow Shaft with Shrink Disc

Reductions

2 — Double

3 — Triple

4 — Quadruple

5 — Quintuple

Model

A, B, C, etc.

Variance Symbol

Variance Symbol is omitted when Standard Mineral Lube and Single Seals are specified

A — Standard Mineral Lube and Double Seals

B — Synthetic Lube and Single Seals

C — Biodegradable Lube and Single Seals

D — Food Compatible Lube and Single Seals

E — Synthetic Lube with Double Seals

F — Biodegradable Compatible Lube with Double Seals

G — Food Compatible Lube with Double Seals

H — Backstop (Hold Back)

S — Multiple Variances or Special

R — Rubber Bushing Kit

Ratio Code, Three Characters, refer to page 11

5.0 through 100 — Double Reduction

83. through 355 — Triple Reduction

360 through 56C — Quadruple Reduction

C = 00

Input Type

A — NEMA Flange Motor

G — IEC Flange Motor

N — Gear Drive with Inch Input

C — Gear Drive with Metric Input

Drive Mounting Position, refer to page 12

Mounting Positions 1 through 6

Motor Adapter Symbol, refer to page 13

A through W

Motor Mounting Position, refer to page 12 ★

When viewed from L.S. Shaft of Base-Mounted Drive with Mounting Feet Down

A — Conduit Box Horizontal on Right Side, 0°

B — Conduit Box Vertical on Bottom Side, 90°

C — Conduit Box Horizontal on Left Side, 180°

D — Conduit Box Vertical on Top Side of Drive 270°

★ Motor Power, Motor Poles and Motor Mounting Position are stamped on the nameplate only if the motor is furnished and fitted by the Factory.

Service Factors

A gear drive is rated to a specified application by the use of Service Factors. Each application has its own conditions and operating requirements. These have been analyzed and cataloged. Numerical values, based on field experience, have been assigned to these classifications for intermittent service of 3 to 10 hours per day and for service over 10 hours per day and also for the type of prime mover ... electric motor or engine. Values for most applications are listed by application on page 10, Table 3 and by industry at right, Table 2.

Examples — A comparison of three different applications, each operating 16 hours per day, will illustrate the function of Service Factors: an Assembly Conveyor, uniformly-loaded (SF = 1.25), a Belt Conveyor, heavy-duty (SF = 1.50) and a Laundry Washer (SF = 2.00). If each of these applications requires 10 hp, each drive is selected for a rating of 10 hp times the Service Factor — that is, for 12.5, 15 and 20 hp respectively. Thus, the Service Factor takes into consideration the varying conditions of operation: Laundry Washer service is relatively more severe than that of a uniformly-loaded Assembly Conveyor, etc.

Application	Service	
	3 to 10 Hour	Over 10 Hour
ASSEMBLY CONVEYORS		
Uniformly-Loaded or Fed	1.25	1.25
BELT CONVEYORS		
Heavy-Duty	1.25	1.50
LAUNDRY WASHERS	1.50	2.00

Since most industrial applications are electric-motor-driven, Service Factors are based on the use of electric motors. These factors can be easily converted to engine-drive factors as outlined in Table 1.

Service Factors are based on the assumption that the system is free of dynamic vibrations, as explained in the Basic Information section, and that maximum momentary or starting loads do not exceed 200% of the rated load.

Service Factors listed are recommended as minimum for general purpose use. Application of these service factors will result in normal drive reliability and life under typical operation conditions. Refer to Factory any application not listed in Table 2 or Table 3.

Applications involving unusual operating conditions or requirements such as, but not limited to, the following should also be referred to Factory:

- Applications requiring extended life/High-reliability, exceeding normal
- High frequency starting
- Stalling or other high-energy load absorption
- Torsional vibrations
- Frequent speed variations
- Reversing loads
- Extremes in ambient temperature

Occasional & Intermittent Service or Engine Driven Applications

For multi-cylinder engine-driven applications and all applications operating intermittently up to 3 hours per day, refer to Table 2 or Table 3 for the Service Factor of the same application operating 3 to 10 hours per day. Next, in the first column of Table 1, find this same Service Factor. Then, to the right, under the desired hours service and prime mover, locate the converted Service Factor.

For example, from Table 3, the Service Factor is 1.25 for a uniformly-loaded belt conveyor. From Table 1, for the same application the following are the Service Factors for various conditions.

1. Engine-driven 3 to 10 hours per day; use 1.50 Service Factor.
2. Engine-driven up to 3 hours intermittently; use 1.25 Service Factor.
3. Motor-driven up to 3 hours intermittently; use 1.00 Service Factor.

Table 1 — Service Factor Conversions

Table 2 or Table 3 3 to 10 Hour Service Factor	3 to 10 Hours per Day	Over 10 Hours per Day		Intermittent – Up to 3 Hours per Day ▲	
	Multi-Cyl. Engine ◆	Motor	Multi-Cyl. Engine ◆	Motor	Multi-Cyl. Engine ◆
1.00	1.25	1.25	1.50	1.00	1.00
1.25	1.50	1.50	1.75	1.00	1.25
1.50	1.75	1.75	2.00	1.25	1.50
1.75	2.00	2.00	2.25	1.50	1.75
2.00	2.25	2.25	2.50	1.75	2.00

▲ For applications operating one half hour or less per day and applications driven by single cylinder engines, refer to Factory.

◆ These service factors are based on the assumption that the system is free from serious critical and torsional vibrations and that maximum momentary or starting loads do not exceed 200% of the normal load.

Table 2 — Type UJ Service Factors Listed by Industry

(For electric motor, steam turbine or hydraulic motor drives ... recommendations are MINIMUM and normal conditions are assumed.)

Industry	Service		Industry	Service	
	3 to 10 Hour	Over 10 Hour		3 to 10 Hour	Over 10 Hour
BOTTLING AND BREWING					
Bottling Machinery.....	1.25	1.25	Jordan	–	1.50
Brew Kettles, Continuous Duty.....	1.25	1.25	Kiln Drive.....	–	1.50
Can Filling Machines	1.25	1.25	Mt. Hope & Paper Rolls	–	1.50
Cookers — Continuous Duty.....	1.25	1.25	Platter.....	–	1.50
Mash Tubs — Continuous Duty	1.25	1.25	Presses (Felt & Suction)	–	1.50
Scale Hoppers — Frequent Starts	1.25	1.50	Reel (Surface Type)	–	1.50
CLAY WORKING INDUSTRY					
Clay Working Machinery.....	1.25	1.50	Screens		
Pug Mills	1.25	1.50	Chip & Rotary.....	–	1.50
DISTILLING					
See Brewing			Size Press	–	1.50
FOOD INDUSTRY					
Beet Slicers	1.25	1.50	Thickener & Washer		
Bottling, Can Filling Machine.....	1.25	1.25	AC Motor.....	–	1.50
Cereal Cookers.....	1.00	1.25	DC Motor.....	–	1.50
Dough Mixers, Meat Grinders.....	1.25	1.50	Vacuum Pumps.....	–	1.50
LUMBER INDUSTRY					
Conveyors			Wind & Unwind Stand.....	–	1.25
Burner	1.25	1.50	Winders (Surface Type).....	–	1.25
Main or Heavy-Duty.....	1.50	1.50	PLASTIC INDUSTRY		
Re-Saw Merry-Go-Round.....	1.25	1.50	Batch Drop Mill, 2 smooth rolls	1.25	1.25
Slab	1.75	2.00	Calenders.....	1.50	1.50
Transfer.....	1.25	1.50	Compounding Mills.....	1.25	1.25
Chains — Floor.....	1.50	1.50	Continuous Feed, Holding & Blend Mill	1.25	1.25
Chains — Green.....	1.50	1.75	Intensive Internal Mixers		
Cut-Off Saws — Chain & Drag	1.50	1.75	Batch Mixers.....	1.75	1.75
Feeds — Edger.....	1.25	1.50	Continuous Mixers	1.50	1.50
Feeds — Gang.....	1.75	1.75	RUBBER INDUSTRY		
Feeds — Trimmer	1.25	1.50	Batch Drop Mill, 2 smooth rolls	1.50	1.50
Log Turning Devices	1.75	1.75	Calenders.....	1.50	1.50
Planer Feed	1.25	1.50	Cracker Warmer — 2 roll, 1 corrugated roll.....	1.75	1.75
Planer Tilting Hoists.....	1.50	1.50	Holding, Feed & Blend Mill — 2 Roll	1.25	1.25
Rolls — Live — Off Bearing — Roll Cases.....	1.75	1.75	Intensive Internal Mixers		
Sorting Table, Tipple Hoist.....	1.25	1.50	Batch Mixers.....	2.00	2.00
Transfers—Chain & Craneway	1.75	2.00	Continuous Mixers	1.50	1.50
Tray Drives	1.25	1.50	Mixing Mill — 2 smooth rolls (if corrugated rolls are used, use Cracker Warmer service factors)	1.50	1.50
OIL INDUSTRY					
Chillers.....	1.25	1.50	Refiner — 2 roll.....	1.50	1.50
Paraffin Filter Press.....	1.25	1.50	SEWAGE DISPOSAL		
Rotary Kilns	1.25	1.50	Bar Screens.....	1.25	1.25
PAPER MILLS ●					
Agitator (Mixer).....	–	1.50	Chemical Feeders.....	1.25	1.25
Agitator for Pure Liquids	–	1.50	Collectors.....	1.25	1.25
Beater	–	1.50	Dewatering Screens	1.50	1.50
Breaker Slack	–	1.50	Scum Breakers	1.50	1.50
▼ Calender	–	1.50	Slow or Rapid Mixers.....	1.50	1.50
Chipper	–	2.00	Thickeners.....	1.50	1.50
Chip Feeder.....	–	1.50	Vacuum Filters	1.50	1.50
Coating Rolls	–	1.50	TEXTILE INDUSTRY		
Conveyors — Chip, Bark, Chemical	–	1.50	Batchers, Calenders	1.25	1.50
Couch Rolls	–	1.50	Card Machines.....	1.25	1.50
Cylinder molds.....	–	1.50	Dry Cans, Dryers.....	1.25	1.50
▼ Dryers — Paper Mach. & Conveyor Type	–	1.50	Dyeing Machinery.....	1.25	1.50
Embossing	–	1.50	Looms, Mangles, Nappers, Pads.....	1.25	1.50
Extruder.....	–	1.50	Slashers, Soapers, Spinners, Tenter Frames, Washers, Winders	1.25	1.50
Fourdrinier Rolls — Lumpbreaker, Wire Turning Dandy & Return Rolls	–	1.50			

● Service factors for paper mill applications are applied to the nameplate rating of the electric drive motor at the motor-rated base speed and are consistent with those shown in TAPPI standards.

▼ Anti-friction bearings only.

Service Factors

Table 3 — Type UJ Service Factors Listed by Application

(For electric motor, steam turbine or hydraulic motor drives ... recommendations are MINIMUM and normal conditions are assumed.)

Application	Service		Application	Service		Application	Service		Application	Service	
	3 to 10 Hour	Over 10 Hour		3 to 10 Hour	Over 10 Hour		3 to 10 Hour	Over 10 Hour		3 to 10 Hour	Over 10 Hour
AGITATORS			Reciprocating Multi-Cylinder	1.50	1.75	GRAVITY DISCHARGE ELEVATORS	1.00	1.25	Proportioning.....	1.25	1.50
Pure Liquids.....	1.25	◆ 1.25 ◆	CONCRETE MIXERS			▲ HOISTS			Reciprocating		
Liquids & Solids.....	◆ 1.25 ◆	◆ 1.50 ◆	Continuous	1.25	1.50	Medium Duty	1.25	1.50	Single-Act., 3 or more Cyl.....	1.25	1.50
Liquids-Variable Density	◆ 1.25 ◆	◆ 1.50 ◆	Intermittent.....	1.25	1.50	Skip Hoist	1.25	1.50	Double-Act., 2 or more Cyl.....	1.25	1.50
APRON CONVEYORS			CONVEYORS — Uniformly-loaded or Fed:			INDUCED DRAFT FANS	1.25	1.50	Rotary: Gear, Lobe, Vane.....	1.25	1.25
Uniformly-Loaded or Fed	1.25	1.50	CONVEYORS — Heavy-Duty, Not Uniformly Fed			KILNS	See Mills, Rotary		RECIPROCATING COMPRESSORS		
Heavy-Duty	1.25	1.50	Apron, Assembly, Belt, Bucket, Chain, Flight, Oven, Screw.....	1.25	1.25	LAUNDRY WASHERS	1.50	2.00	Multi-Cylinder.....	1.50	1.75
APRON FEEDERS	1.25	1.50	CONVEYORS — Heavy-Duty, Not Uniformly Fed			LAUNDRY TUMBLERS	1.25	1.50	ROTARY		
ASSEMBLY CONVEYORS			Apron, Assembly, Belt, Bucket, Chain, Flight, Oven, Screw.....	1.25	1.50	LINE SHAFTS			Pumps.....	1.25	1.25
Uniformly-Loaded or Fed	1.25	1.25	COOKERS (Brewing & Distilling), (Food)	1.25	1.25	Driving Processing Equipment.....	1.25	1.50	Screens (Sand or Gravel).....	1.25	1.50
Heavy-Duty	1.25	1.50	DEWATERING SCREENS (Sewage)	1.50	1.50	Other Line Shafts, Light.....	1.25	1.25	RUBBER & PLASTICS INDUSTRIES	See Table 2	
BALL MILLS	See Mills, Rotary		DISC FEEDERS	1.25	1.25	LOBE BLOWERS OR COMPRESSORS	1.25	1.50	SAND MULLERS	1.25	1.50
BAR SCREENS (Sewage)	1.25	1.25	DISTILLING	See Table 2		LOOMS (Textile)	1.25	1.50	SCREENS		
BATCHERS (Textile)	1.25	1.50	DOUBLE-ACTING PUMPS			LUMBER INDUSTRY	See Table 2		Air Washing	1.00	1.25
BELT CONVEYORS			2 or more Cylinders	1.25	1.50	MACHINE TOOLS			Rotary — Sand or Gravel.....	1.25	1.50
Uniformly-Loaded or Fed	1.25	1.25	DOUGH MIXER (Food)	1.25	1.50	Auxiliary Drives.....	1.25	1.25	Traveling Water Intake.....	1.00	1.25
Heavy-Duty	1.25	1.50	DRAW BENCH (Metal Mills)			Bending Rolls.....	1.25	1.50	SCREW CONVEYORS		
BELT FEEDERS	1.25	1.50	Carriage & Main Drive	1.25	1.50	Main Drives.....	1.25	1.50	Uniform.....	1.25	1.25
BENDING ROLLS (Machine)	1.25	1.50	DRYERS & COOLERS			Punch Press (Geared)	1.75	2.00	Heavy-Duty or Feeder.....	1.25	1.50
BLOWERS			(Mills, Rotary)	—	1.50	Tapping machines	1.75	2.00	SCUM BREAKERS (Sewage)	1.50	1.50
Centrifugal	1.25	1.25	DYEING MACHINERY (Textile)	1.25	1.50	MANGLE (Textile)	1.25	1.50	SEWAGE DISPOSAL	See Table 2	
Lobe	1.25	1.50	ELEVATORS			MASH TUBS (Brewing & Distilling)	1.25	1.25	SHAKER CONVEYORS	1.75	2.00
Vane	1.25	1.50	Bucket-Uniform-Lood	1.25	1.50	MEAT GRINDERS (Food)	1.25	1.50	SHEETERS (Rubber)	—	1.50
BOTTLING MACHINERY	1.25	1.25	Bucket-Heavy-Duty	1.25	1.50	METAL MILLS			SINGLE ACTING PUMP		
BREWING	See Table 2		Bucket-Continuous	1.25	1.50	Draw Bench Carriages & Main Drives	1.25	1.50	3 or more Cylinders	1.25	1.50
BUCKET			Centrifugal Discharge	1.25	1.25	Pinch, Dryer & Scrubber			▲ SKI TOWS & LIFTS	Not Approved	
Conveyors Uniform	1.25	1.50	▲ Escalators	Not Approved		Rolls, Reversing.....	Refer to Factory		▲ SKIP HOIST	1.25	1.50
Conveyors Heavy-Duty	1.25	1.50	▲ Freight	Not Approved		Slitters.....	1.25	1.50	SLAB PUSHERS	1.50	1.50
Elevators Continuous	1.25	1.50	Gravity Discharge	1.25	1.25	Table Conveyors, Non-Reversing			SLITTERS (Metal)	1.25	1.50
Elevators Uniform.....	1.25	1.50	▲ Man Lifts, Passenger	Not Approved		Group Drives	1.50	1.50	SLUDGE COLLECTORS (Sewage) ...	1.25	1.25
Elevators Heavy-Duty.....	1.25	1.50	EXTRUDERS (Plastic & Rubber)	See Table 2		Wire Drawing & Flattening Machines....	1.25	1.50	SOAPERS (Textile)	1.25	1.50
CALENDERS			FANS			Wire Winding Machines.....	1.50	1.50	SPINNERS (Textile)	1.25	1.50
Rubber and Plastic	See Table 2		Centrifugal	1.25	1.25	MILLS, ROTARY			STOKERS	1.25	1.25
Textile.....	1.25	1.50	Forced Draft.....	—	1.25	Pebble, Plain & Wedge Bar Mills	—	1.50	TABLE CONVEYORS (Non-Reversing)		
CAN FILLING MACHINES	1.25	1.25	Induced Draft.....	1.50	1.50	Constant Density.....	1.25	◆ 1.50 ◆	Group Drives.....	1.50	1.50
CARD MACHINES (Textile)	1.25	1.50	Large (Mine, etc.).....	1.50	1.50	Concrete, Cont. & Int.	1.25	◆ 1.50 ◆	TENTER FRAMES (Textile).....	1.25	1.50
CAR PULLERS	1.25	1.50	Large Industrial	1.50	1.50	Constant Density.....	1.25	◆ 1.50 ◆	TEXTILE INDUSTRY	See Table 2	
CEMENT KILNS	See Mills, Rotary		Light (Small Diameter).....	1.00	1.25	Variable Density	1.25	◆ 1.50 ◆	THICKENERS (Sewage)	1.50	1.50
CENTRIFUGAL			FEEDERS			NAPPERS (Textile)	1.25	1.50	VACUUM FILTERS (Sewage)	1.50	1.50
Blowers, Compressors, Discharge			Apron, Belt	1.25	1.50	OIL INDUSTRY	See Table 2		VANE BLOWERS	1.25	1.50
Elevators, Fans or Pumps	1.25	1.25	Disc.....	1.25	1.25	OVEN CONVEYORS			WINCHES (Dredges)	1.25	1.50
CHAIN CONVEYORS			Screw.....	1.25	1.50	Uniform.....	1.25	1.25	WINDERS (Textile)	1.25	1.50
Uniformly-Loaded or Fed	1.25	1.25	FLIGHT CONVEYORS			Heavy-Duty	1.25	1.50	WIRE		
Heavy-Duty	1.25	1.50	Uniform.....	1.25	1.25	PAPER MILLS	See Table 2		Drawing Machines	1.25	1.50
CHEMICAL FEEDERS (Sewage)	1.25	1.25	Heavy	1.25	1.50	PASSENGER ELEVATORS	Not Approved		Winding Machines.....	1.50	1.50
CLARIFIERS	1.25	1.25	FOOD INDUSTRY	See Table 2		PEBBLE MILLS	—	1.50			
CLASSIFIERS	1.25	1.50	GENERATORS (Not Welding)	1.25	1.25	PROPORTIONING PUMPS	1.25	1.50			
CLAY WORKING	See Table 2					PUG MILLS (Clay)	1.25	1.50			
COLLECTORS (Sewage)	1.25	1.25				PUMPS					
COMPRESSORS						Centrifugal	1.25	1.25			
Centrifugal	1.25	1.25									
Lobe.....	1.25	1.50									

- ▲ Selection of Rexnord products for applications whose primary purpose is the transportation of people is not approved. This includes such applications as freight or passenger elevators, escalators, man lifts, work lift platforms, ski tows and ski lifts. If the primary purpose of the application is material conveyance and occasionally people are transported, the Factory warranty may remain in effect provided the design load conditions are not exceeded and certification to the appropriate safety codes and load conditions has been obtained by the system designer or end user from the appropriate enforcement authorities.
- ◆ Contact your local Rexnord representative for proper selection of a Falk RAM mixer drive.

300UJ — Exact Ratios

Double Reduction

Nominal Ratio (3 Characters)	Drive Size							
	302	304	306	307	308	309	310	312
3.1	—	—	2.97	3.25	3.19	3.16	3.11	—
3.5	3.47	—	3.45	3.64	3.52	3.51	3.52	—
4.0	3.97	—	3.86	4.19	4.06	4.18	3.99	—
4.5	4.26	4.65	4.42	4.75	4.58	4.49	4.52	—
5.0	4.90	5.33	4.85	5.35	5.06	5.19	4.93	—
5.6	5.66	5.71	5.60	6.13	5.74	5.81	5.62	—
6.3	6.10	6.57	6.19	6.77	6.43	6.35	6.25	—
7.1	6.59	7.60	6.87	7.44	7.10	7.05	7.08	—
8.0	7.73	8.19	8.07	7.87	8.17	8.40	8.02	—
9.0	8.46	9.36	9.37	8.82	9.23	9.02	9.10	—
10.	9.69	10.73	10.49	10.15	10.19	10.43	9.91	—
11.	10.39	11.50	12.01	11.51	11.56	11.66	11.31	—
12.	11.95	13.23	13.18	12.95	13.00	12.59	12.38	—
14.	13.82	15.30	15.23	14.85	14.45	14.18	14.26	—
16.	16.08	16.49	16.83	16.38	16.45	16.06	15.73	—
18.	18.87	17.80	18.68	18.03	17.75	17.51	17.68	—
20.	20.52	20.89	20.01	20.31	19.68	20.08	19.69	—
22.	22.40	22.72	23.40	22.52	22.65	23.26	22.06	—
25.	24.55	27.18	25.20	25.80	25.55	25.85	24.90	—
28.	27.02	29.92	28.62	30.30	29.09	27.61	28.02	—
31.	29.91	33.11	32.41	32.42	31.91	30.69	32.32	—
35.	37.42	36.89	35.34	36.21	36.58	34.82	35.33	—
40.	41.65	41.43	40.91	41.31	39.65	38.01	38.31	—
45.	46.58	46.12	45.17	44.79	46.78	43.51	45.22	—
50.	49.00	51.57	54.05	51.70	52.18	47.54	49.92	—
56.	54.15	59.95	60.18	56.78	58.03	56.00	55.55	—
63.	60.33	66.79	66.57	67.76	—	61.68	—	—
71.	74.98	68.94	73.95	75.97	—	68.49	—	—
80.	83.24	83.01	77.94	—	—	—	—	—
90.	93.33	92.15	85.68	—	—	—	—	—
100	—	103.33	106.33	—	—	—	—	—

Triple Reduction

Nominal Ratio (3 Characters)	Drive Size							
	302	304	306	307	308	309	310	312
8.0	—	—	—	—	—	—	—	7.57
9.0	—	—	—	—	—	—	—	8.57
10.	—	—	—	—	—	—	—	9.70
11.	—	—	—	—	—	—	—	11.01
12.	—	—	—	—	—	—	—	12.00
14.	—	—	—	—	—	—	—	13.97
16.	—	—	—	—	—	—	—	15.81
18.	—	—	—	—	—	—	—	17.91
20.	—	—	—	—	—	—	—	20.32
22.	—	—	—	—	—	—	—	22.14
25.	—	—	—	—	—	—	—	25.26
28.	—	—	—	—	—	—	—	27.66
31.	—	—	—	—	—	—	—	31.85
35.	—	—	—	35.83	33.69	—	—	35.14
40.	—	—	—	41.39	37.78	38.12	39.42	39.49
45.	—	—	—	45.75	43.49	42.75	44.20	43.97
50.	—	—	—	50.79	49.30	49.20	50.88	49.26
56.	—	—	—	54.40	55.45	55.78	57.68	55.62
63.	—	—	—	63.60	63.59	62.74	64.88	62.59
71.	—	—	—	68.51	70.17	71.94	74.39	72.20
80.	—	—	—	77.80	77.21	79.38	82.09	78.91
90.	—	—	—	88.11	86.98	87.35	90.33	85.57
100	—	—	—	96.08	96.48	98.40	101.75	101.01
112	—	—	—	111.21	110.51	109.15	112.87	111.49
125	—	—	—	122.80	129.77	125.03	129.29	124.07
140	—	—	—	146.92	138.87	146.82	151.82	—
160	—	—	—	163.58	155.10	157.12	162.47	—
180	—	—	—	180.96	176.96	175.48	181.46	—
200	—	—	—	201.03	191.86	200.21	207.03	—
224	—	—	—	—	221.46	217.07	224.46	—
250	—	—	—	—	243.22	250.56	259.09	—
280	—	—	—	—	290.23	275.17	284.55	—
315	—	—	—	—	325.39	—	—	—
355	—	—	—	—	—	—	—	—
400	—	—	—	—	—	—	—	—

Quadruple Reduction

Nominal Ratio (3 Characters)	Drive Size							
	302	304	306	307	308	309	310	312
100	97.10	101.80	99.85	—	—	—	—	—
112	113.00	108.10	107.00	—	—	—	—	—
125	129.20	125.10	123.10	—	—	—	—	—
140	139.30	143.90	142.30	—	—	—	—	—
160	162.10	154.20	153.50	—	—	—	—	—
180	174.90	179.40	183.10	—	—	—	—	—
200	205.10	195.20	194.30	—	—	—	—	—
224	223.30	227.10	219.00	—	—	—	—	—
250	252.60	247.20	252.90	—	—	—	—	—
280	279.70	273.80	278.30	287.40	289.00	272.40	279.40	—
315	325.40	309.60	308.20	312.90	314.60	318.60	299.30	—
355	362.50	360.30	343.30	374.10	376.20	389.70	350.00	—
400	407.10	401.40	385.50	411.70	414.10	441.30	376.90	—
450	453.00	450.70	440.20	455.90	458.40	481.20	428.10	—
500	506.70	501.60	483.00	507.90	510.80	556.90	484.80	—
560	564.10	561.00	557.80	570.30	573.50	556.90	528.70	—
630	606.30	624.50	621.50	634.70	638.30	615.00	611.80	—
710	677.30	726.60	733.20	710.00	713.90	735.80	675.60	—
800	815.50	749.80	816.80	825.30	829.90	819.30	808.40	—
900	—	902.90	947.80	919.40	924.60	906.30	900.10	—
1000 (10C)	—	—	1015.00	948.90	954.00	1007.00	996.00	—
1120 (11C)	—	—	—	1143.00	1149.00	—	1106.00	—

Quintuple Reduction

Nominal Ratio (3 Characters)	Drive Size							
	302	304	306	307	308	309	310	312
180	—	—	—	—	—	—	—	174.39
200	—	—	—	—	—	—	—	202.42
224	—	—	—	—	—	—	—	226.65
250	—	—	—	—	—	—	—	259.50
280	—	—	—	—	—	—	—	284.71
315	—	—	—	—	—	—	—	328.84
355	—	—	—	—	—	—	—	363.52
400	—	—	—	—	—	—	—	403.53
450	—	—	—	—	—	—	—	432.19
500	—	—	—	—	—	—	—	505.37
560	—	—	—	—	—	—	—	544.34
630	—	—	—	—	—	—	—	618.13
710	—	—	—	—	—	—	—	700.06
800	—	—	—	—	—	—	—	763.39
900	—	—	—	—	—	—	—	883.63
1000 (10C)	—	—	—	—	—	—	—	956.13
1120 (11C)	—	—	—	—	—	—	—	1082.86
1200 (12C)	—	—	—	—	—	—	—	—

300UJ — Drive Mounting Position

MOUNTING 1

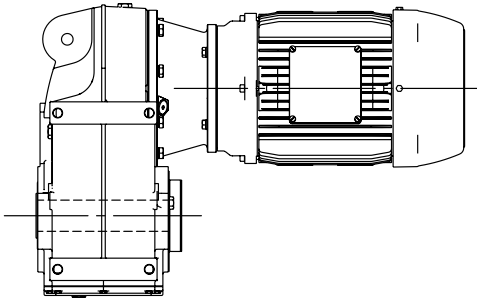

MOUNTING 2

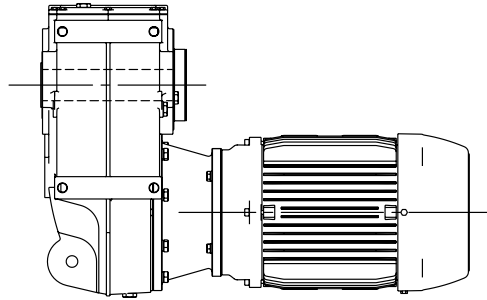

MOUNTING 3

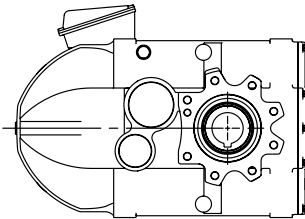

MOUNTING 4

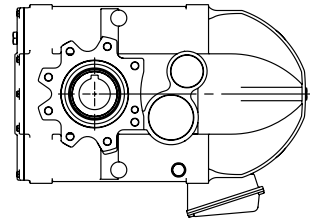

MOUNTING 5

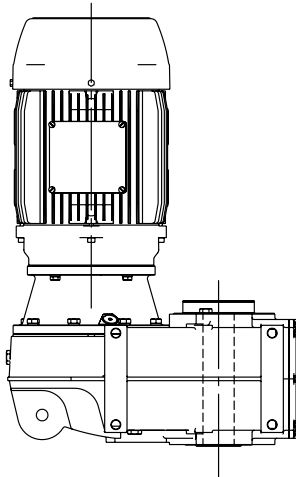

MOUNTING 6

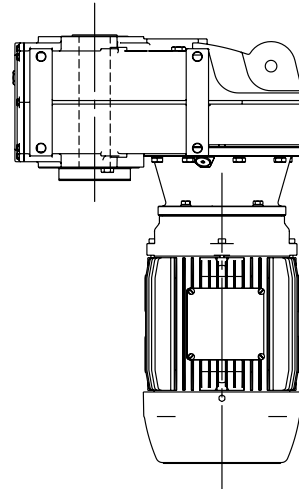

D (270°)

C (180°)

A (0°)

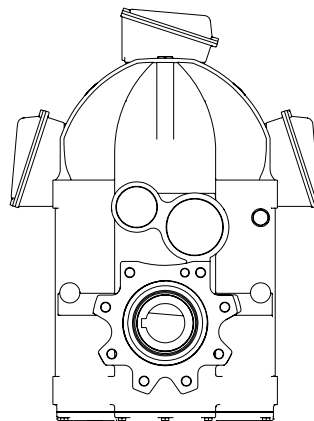

B (90°)
ALL MOTORS

Motor Mounting Position

Conduit box position when viewed from L.S. end of drive.

- A – Conduit box horizontal on right side, 0°.
- B – Conduit box vertical on bottom side, 90°.
- C – Conduit box horizontal on left side, 180°.
- D – Conduit box vertical on top side, 270°.

Standard NEMA motor mounting position is "C".

Standard IEC motor mounting position is "A".

300UJ — Motor Adapters

The Ultramite shaft mounted gearmotor accommodates NEMA (Input Type "A") or IEC (Input Type "G") motor frame sizes. Table 1 and Table 2 below identify the appropriate motor adapter symbol that pertains to specific motor frame size, drive size, ratio and reduction combinations.

If a motor adapter symbol is not listed for a particular combination of motor frame size, drive size, ratio and reduction, then that combination is not offered.

For gear drives (Input Types "N" and "C"), the motor adapter symbol is not used.

Table 4 — Input Type A – NEMA Motor Adapter Symbols

Motor Frame Size	Drive Size															
	302		304		306		307		308		309		310		312	
	Double	Triple	Double	Triple	Double	Triple	Double	Triple	Double	Triple	Double	Triple	Double	Triple	Double	Triple
56C	A	–	A	–	A	–	A	A	A	A	–	–	–	–	–	–
143TC/145TC	B	–	B	–	B	–	B	B	B	B	–	–	–	–	–	–
182TC/184TC	C	–	C	–	C	–	C	C	C	C	C	C	C	C	–	C
213TC/215TC	–	–	D	–	D	–	D	D	D	D	D	D	D	D	–	D
254TC/256TC	–	–	–	–	–	–	E	–	E	E	E	E	E	E	–	E
284TC/286TC	–	–	–	–	–	–	–	–	–	–	F	F	F	F	–	F
324TC/326TC	–	–	–	–	–	–	–	–	–	–	G	G	G	G	–	G

Table 5 — Input Type G – IEC Motor Adapter Symbols

Motor Frame Size	Drive Size															
	302		304		306		307		308		309		310		312	
	Double	Triple	Double	Triple	Double	Triple	Double	Triple	Double	Triple	Double	Triple	Double	Triple	Double	Triple
63/D	A	A	A	A	A	A	A	A	A	A	A	A	A	A	A	A
71/B	B	B	B	B	B	B	B	B	B	B	B	B	B	B	B	B
80/D	C	C	C	C	C	C	C	C	C	C	C	C	C	C	C	C
90/D	D	D	D	D	D	D	D	D	D	D	D	D	D	D	D	D
100/A	E	E	E	E	E	E	E	E	E	E	E	E	E	E	E	E
100/B	F	F	F	F	F	F	F	F	F	F	F	F	F	F	F	F
112/M	G	G	G	G	G	G	G	G	G	G	G	G	G	G	G	G
132/S	–	–	–	–	H	H	H	H	H	H	H	H	H	H	H	H
160/L	–	–	–	–	J	J	J	J	J	J	J	J	J	J	J	J
160/M	–	–	–	–	K	K	K	K	K	K	K	K	K	K	K	K
180/L	–	–	–	–	–	–	M	M	M	M	M	M	M	M	M	M
180/M	–	–	–	–	–	–	N	N	N	N	N	N	N	N	N	N
200/L	–	–	–	–	–	–	–	–	P	P	P	P	P	P	P	P
225/M	–	–	–	–	–	–	–	–	–	–	R	R	R	R	R	R
225/S	–	–	–	–	–	–	–	–	–	–	T	T	T	T	T	T
250/M	–	–	–	–	–	–	–	–	–	–	U	U	U	U	U	U
280/M	–	–	–	–	–	–	–	–	–	–	–	–	–	–	–	–
280/S	–	–	–	–	–	–	–	–	–	–	–	–	–	–	–	–

Motor Detail (NEMA C-Face)

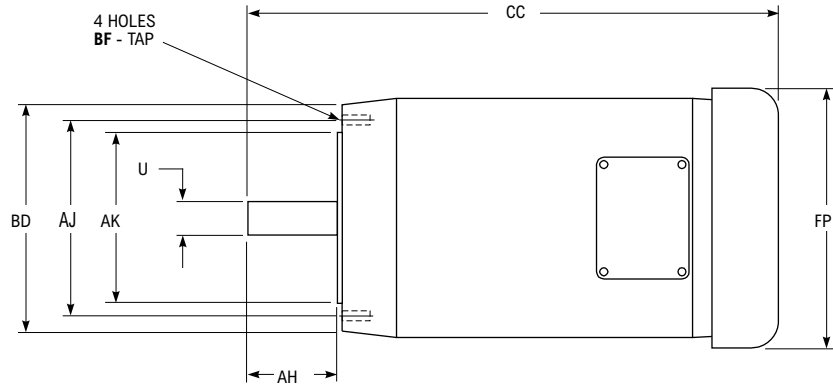

Table 6 — Typical Motor Dimensions (in)

Motor Frame Size	BD	AJ	AK	U	AH	CC Max	FP	BF Tap UNC
56C	6.50	5.88	4.5	0.625	2.06	11.38	7.19	0.375-16
143TC/145TC	6.50	5.88	4.5	0.875	2.12	14.19	7.19	0.375-16
182TC/184TC	9.00	7.25	8.5	1.125	2.63	18.06	8.50	0.50-13
213TC/215TC	9.00	7.25	8.5	1.375	3.13	19.44	10.19	0.50-13
254TC/256TC	10.00	7.25	8.5	1.625	3.75	23.63	12.50	0.50-13
284TC/286TC	11.25	9.00	10.5	1.875	4.38	27.56	15.56	0.50-13
324TC/326TC	13.38	11.00	12.5	2.125	5.00	30.25	16.94	0.63-11
364TC/365TC	13.38	11.00	12.5	2.375	5.63	32.56	19.00	0.63-11
404TC/405TC	13.88	11.00	12.5	2.875	7.00	36.88	20.63	0.63-11

300UJ — Gearmotor Selection Table

0.25 HP/1750 RPM/56C Frame Motor

Approx Output RPM	Service Factor	Exact Ratio	Actual Output Torque (lb-in)	Overhung Load (lb)	Drive Designation
504	24.93	3.47	31	560	302UJJAQ2A3.5A_A
441	25.01	3.97	36	560	302UJJAQ2A4.0A_A
411	25.84	4.26	38	560	302UJJAQ2A4.5A_A
357	25.08	4.90	44	570	302UJJAQ2A5.0A_A
309	24.96	5.67	51	550	302UJJAQ2A5.6A_A
287	24.98	6.10	55	570	302UJJAQ2A6.3A_A
266	24.61	6.59	59	600	302UJJAQ2A7.1A_A
226	20.98	7.73	70	620	302UJJAQ2A8.0A_A
207	24.98	8.46	76	620	302UJJAQ2A9.0A_A
181	23.33	9.69	87	630	302UJJAQ2A10.A_A
168	21.76	10.39	94	660	302UJJAQ2A11.A_A
146	18.92	11.95	108	700	302UJJAQ2A12.A_A
127	16.36	13.82	124	760	302UJJAQ2A14.A_A
109	14.06	16.08	145	800	302UJJAQ2A16.A_A
92.7	11.98	18.87	170	850	302UJJAQ2A18.A_A
85.3	11.02	20.52	185	900	302UJJAQ2A20.A_A
71.3	9.21	24.55	221	1000	302UJJAQ2A25.A_A
64.8	8.37	27.02	243	1050	302UJJAQ2A28.A_A
58.5	7.56	29.91	269	1100	302UJJAQ2A31.A_A
46.8	6.04	37.42	337	1100	302UJJAQ2A35.A_A
42.0	5.43	41.65	375	1100	302UJJAQ2A40.A_A
37.6	4.85	46.58	419	1100	302UJJAQ2A45.A_A
32.3	4.18	54.15	488	1100	302UJJAQ2A56.A_A
29.0	3.75	60.33	543	1100	302UJJAQ2A63.A_A
23.3	3.02	74.98	675	1100	302UJJAQ2A71.A_A
21.0	2.72	83.24	749	1100	302UJJAQ2A80.A_A
19.0	3.57	92.15	830	1550	304UJJAQ2A90.A_A
18.8	2.42	93.33	840	1100	302UJJAQ2A90.A_A
18.0	2.33	97.10	874	1100	302UJJAQ4A100A_A
16.9	2.95	103.33	930	1550	304UJJAQ2A100A_A
15.5	2.00	113.00	1017	1100	302UJJAQ4A112A_A
14.0	3.46	125.10	1126	1550	304UJJAQ4A125A_A
13.5	1.75	129.20	1163	1100	302UJJAQ4A125A_A
12.2	3.01	143.90	1296	1550	304UJJAQ4A140A_A
11.6	1.62	139.30	1254	1100	302UJJAQ4A140A_A
11.4	2.80	154.20	1388	1550	304UJJAQ4A160A_A
10.8	1.39	162.10	1459	1100	302UJJAQ4A160A_A
10.0	1.29	174.90	1575	1100	302UJJAQ4A180A_A
9.76	2.41	179.40	1615	1550	304UJJAQ4A180A_A
8.96	2.22	195.20	1757	1550	304UJJAQ4A200A_A
8.53	1.10	205.10	1847	1100	302UJJAQ4A200A_A
7.84	1.01	223.30	2010	1100	302UJJAQ4A224A_A
7.70	1.90	227.10	2045	1550	304UJJAQ4A224A_A
7.08	1.75	247.20	2226	1550	304UJJAQ4A250A_A
6.92	3.30	252.90	2277	3000	306UJJAQ4A250A_A
6.39	1.58	273.80	2465	1550	304UJJAQ4A280A_A
6.29	3.00	278.30	2506	3000	306UJJAQ4A280A_A
5.68	2.71	308.20	2775	3000	306UJJAQ4A315A_A
5.65	1.40	309.60	2788	1550	304UJJAQ4A315A_A
5.10	2.43	343.30	3091	3000	306UJJAQ4A355A_A
4.86	1.20	360.30	3244	1550	304UJJAQ4A355A_A
4.54	2.17	385.50	3471	3000	306UJJAQ4A400A_A
4.36	1.08	401.40	3614	1550	304UJJAQ4A400A_A

Approx Output RPM	Service Factor	Exact Ratio	Actual Output Torque (lb-in)	Overhung Load (lb)	Drive Designation
3.98	1.90	440.20	3963	3000	306UJJAQ4A450A_A
3.84	3.67	455.90	4105	4000	307UJJAQ4A450A_A
3.62	1.73	483.00	4349	3000	306UJJAQ4A500A_A
3.45	3.29	507.90	4573	4000	307UJJAQ4A500A_A
3.14	1.50	557.80	5022	3000	306UJJAQ4A560A_A
3.07	2.93	570.30	5135	4000	307UJJAQ4A560A_A
2.82	1.34	621.50	5596	3000	306UJJAQ4A630A_A
2.76	2.63	634.70	5715	4000	307UJJAQ4A630A_A
2.47	2.35	710.00	6393	4000	307UJJAQ4A710A_A
2.39	1.14	733.20	6601	3000	306UJJAQ4A710A_A
2.14	1.02	816.80	7354	3000	306UJJAQ4A800A_A
2.12	2.02	825.30	7431	4000	307UJJAQ4A800A_A
2.11	3.43	829.90	7472	6100	308UJJAQ4A800A_A
1.90	1.82	919.40	8278	4000	307UJJAQ4A900A_A
1.89	3.08	924.60	8325	6100	308UJJAQ4A900A_A
1.84	1.76	949.00	8544	4000	307UJJAQ4A10CA_A
1.83	2.99	954.00	8589	6100	308UJJAQ4A10CA_A
1.53	1.46	1143.00	10291	4000	307UJJAQ4A11CA_A
1.52	2.48	1149.00	10345	6100	308UJJAQ4A11CA_A

Motors are available from Rexnord or Rexnord distributors.

0.25 HP/56C Motor
Falk Part No. TBD

Conforms to the following specifications:

C-Face motor less base, TEFC, 1750 rpm, 208–230/460 Volts, 3 Phase, 60 Hz, NEMA B, 1.15 Service Factor.

Motors meeting other specifications are available upon request.

300UJ — Gearmotor Selection Table

0.33 HP/1750 RPM/56C Frame Motor

Approx Output RPM	Service Factor	Exact Ratio	Actual Output Torque (lb-in)	Overhung Load (lb)	Drive Designation
504	18.88	3.47	41	560	302UJAQ2A3.5A_A
441	18.94	3.97	47	560	302UJAQ2A4.0A_A
411	19.58	4.26	51	560	302UJAQ2A4.5A_A
357	19.00	4.90	58	570	302UJAQ2A5.0A_A
309	18.91	5.67	67	550	302UJAQ2A5.6A_A
287	18.92	6.10	72	570	302UJAQ2A6.3A_A
266	18.64	6.59	78	600	302UJAQ2A7.1A_A
226	15.90	7.73	92	620	302UJAQ2A8.0A_A
207	18.92	8.46	101	620	302UJAQ2A9.0A_A
181	17.68	9.69	115	630	302UJAQ2A10.A_A
168	16.48	10.39	123	660	302UJAQ2A11.A_A
146	14.33	11.95	142	700	302UJAQ2A12.A_A
127	12.39	13.82	164	760	302UJAQ2A14.A_A
109	10.65	16.08	191	800	302UJAQ2A16.A_A
92.7	9.08	18.87	224	850	302UJAQ2A18.A_A
85.3	8.35	20.52	244	900	302UJAQ2A20.A_A
71.3	6.98	24.55	292	1000	302UJAQ2A25.A_A
64.8	6.34	27.02	321	1050	302UJAQ2A28.A_A
58.5	5.73	29.91	355	1100	302UJAQ2A31.A_A
46.8	4.58	37.42	445	1100	302UJAQ2A35.A_A
42.0	4.11	41.65	495	1100	302UJAQ2A40.A_A
37.6	3.68	46.58	554	1100	302UJAQ2A45.A_A
32.3	3.16	54.15	644	1100	302UJAQ2A56.A_A
29.0	2.84	60.33	717	1100	302UJAQ2A63.A_A
23.3	2.28	74.98	891	1100	302UJAQ2A71.A_A
21.1	3.23	83.01	987	1550	304UJAQ2A80.A_A
21.0	2.06	83.24	989	1100	302UJAQ2A80.A_A
19.0	2.71	92.15	1095	1550	304UJAQ2A90.A_A
18.8	1.84	93.33	1109	1100	302UJAQ2A90.A_A
18.0	1.76	97.10	1154	1100	302UJAQ4A100A_A
17.2	3.22	101.80	1210	1550	304UJAQ4A100A_A
16.9	2.23	103.33	1228	1550	304UJAQ2A100A_A
16.2	3.03	108.10	1285	1550	304UJAQ4A112A_A
15.5	1.52	113.00	1343	1100	302UJAQ4A112A_A
14.0	2.62	125.10	1487	1550	304UJAQ4A125A_A
13.5	1.33	129.20	1536	1100	302UJAQ4A125A_A
12.2	2.28	143.90	1710	1550	304UJAQ4A140A_A
11.6	1.23	139.30	1656	1100	302UJAQ4A140A_A
11.4	2.12	154.20	1833	1550	304UJAQ4A160A_A
9.76	1.83	179.40	2132	1550	304UJAQ4A180A_A
9.56	3.46	183.10	2176	3000	306UJAQ4A180A_A
9.00	3.26	194.30	2309	3000	306UJAQ4A200A_A
8.96	1.68	195.20	2320	1550	304UJAQ4A200A_A
7.99	2.89	219.00	2603	3000	306UJAQ4A224A_A
7.70	1.44	227.10	2699	1550	304UJAQ4A224A_A
7.08	1.33	247.20	2938	1550	304UJAQ4A250A_A
6.92	2.50	252.90	3006	3000	306UJAQ4A250A_A
6.39	1.20	273.80	3254	1550	304UJAQ4A280A_A
6.29	2.27	278.30	3308	3000	306UJAQ4A280A_A
5.68	2.05	308.20	3663	3000	306UJAQ4A315A_A
5.65	1.06	309.60	3680	1550	304UJAQ4A315A_A
5.10	1.84	343.30	4080	3000	306UJAQ4A355A_A
4.68	3.38	374.10	4446	4000	307UJAQ4A355A_A

Approx Output RPM	Service Factor	Exact Ratio	Actual Output Torque (lb-in)	Overhung Load (lb)	Drive Designation
4.54	1.64	385.50	4582	3000	306UJAQ4A400A_A
4.25	3.07	411.70	4893	4000	307UJAQ4A400A_A
3.98	1.44	440.20	5232	3000	306UJAQ4A450A_A
3.84	2.78	455.90	5418	4000	307UJAQ4A450A_A
3.62	1.31	483.00	5740	3000	306UJAQ4A500A_A
3.45	2.49	507.90	6036	4000	307UJAQ4A500A_A
3.14	1.13	557.80	6629	3000	306UJAQ4A560A_A
3.07	2.22	570.30	6778	4000	307UJAQ4A560A_A
3.05	3.77	573.50	6816	6100	308UJAQ4A560A_A
2.82	1.02	621.50	7386	3000	306UJAQ4A630A_A
2.76	1.99	634.70	7543	4000	307UJAQ4A630A_A
2.74	3.38	638.30	7586	6100	308UJAQ4A630A_A
2.47	1.78	710.00	8438	4000	307UJAQ4A710A_A
2.45	3.02	713.90	8484	6100	308UJAQ4A710A_A
2.12	1.53	825.30	9808	4000	307UJAQ4A800A_A
2.11	2.60	829.90	9863	6100	308UJAQ4A800A_A
1.90	1.38	919.40	10927	4000	307UJAQ4A900A_A
1.89	2.34	924.60	10989	6100	308UJAQ4A900A_A
1.84	1.33	949.00	11279	4000	307UJAQ4A10CA_A
1.83	2.26	954.00	11338	6100	308UJAQ4A10CA_A
1.53	1.11	1143.00	13584	4000	307UJAQ4A11CA_A
1.52	1.88	1149.00	13656	6100	308UJAQ4A11CA_A

Motors are available from Rexnord or Rexnord distributors.

0.33 HP/56C Motor
Falk Part No. TBD

Conforms to the following specifications:

C-Face motor less base, TEFC, 1750 rpm, 208–230/460 Volts, 3 Phase, 60 Hz, NEMA B, 1.15 Service Factor.

Motors meeting other specifications are available upon request.

300UJ — Gearmotor Selection Table

0.50 HP/1750 RPM/56C Frame Motor

Approx Output RPM	Service Factor	Exact Ratio	Actual Output Torque (lb-in)	Overhung Load (lb)	Drive Designation
504	12.46	3.47	62	560	302UJJAQ2A3.5A_A
441	1.25	3.97	715	560	302UJJAQ2A4.0A_C
411	12.92	4.26	77	560	302UJJAQ2A4.5A_A
357	12.54	4.90	88	570	302UJJAQ2A5.0A_A
309	12.48	5.67	102	550	302UJJAQ2A5.6A_A
287	12.49	6.10	110	570	302UJJAQ2A6.3A_A
266	12.31	6.59	119	600	302UJJAQ2A7.1A_A
226	10.49	7.73	139	620	302UJJAQ2A8.0A_A
207	12.49	8.46	152	620	302UJJAQ2A9.0A_A
181	11.67	9.69	174	630	302UJJAQ2A10.A_A
168	10.88	10.39	187	660	302UJJAQ2A11.A_A
146	9.46	11.95	215	700	302UJJAQ2A12.A_A
127	8.18	13.82	249	760	302UJJAQ2A14.A_A
109	7.03	16.08	290	800	302UJJAQ2A16.A_A
92.7	5.99	18.87	340	850	302UJJAQ2A18.A_A
85.3	5.51	20.52	370	900	302UJJAQ2A20.A_A
71.3	4.60	24.55	442	1000	302UJJAQ2A25.A_A
64.8	4.18	27.02	487	1050	302UJJAQ2A28.A_A
58.5	3.78	29.91	539	1100	302UJJAQ2A31.A_A
46.8	3.02	37.42	674	1100	302UJJAQ2A35.A_A
42.0	2.71	41.65	750	1100	302UJJAQ2A40.A_A
37.6	2.43	46.58	839	1100	302UJJAQ2A45.A_A
32.3	2.09	54.15	975	1100	302UJJAQ2A56.A_A
29.2	3.61	59.95	1080	1550	304UJJAQ2A56.A_A
29.0	1.87	60.33	1086	1100	302UJJAQ2A63.A_A
26.2	3.24	66.79	1203	1550	304UJJAQ2A63.A_A
25.4	2.60	68.94	1241	1550	304UJJAQ2A71.A_A
23.3	1.51	74.98	1350	1100	302UJJAQ2A71.A_A
21.1	2.13	83.01	1495	1550	304UJJAQ2A80.A_A
21.0	1.36	83.24	1499	1100	302UJJAQ2A80.A_A
19.0	1.79	92.15	1659	1550	304UJJAQ2A90.A_A
18.8	1.21	93.33	1681	1100	302UJJAQ2A90.A_A
18.0	1.16	97.10	1748	1100	302UJJAQ4A100A_A
17.2	2.12	101.80	1833	1550	304UJJAQ4A100A_A
16.9	1.47	103.33	1861	1550	304UJJAQ2A100A_A
16.5	3.70	106.33	1915	3000	306UJJAQ2A100A_A
16.2	2.00	108.10	1947	1550	304UJJAQ4A112A_A
15.5	1.00	113.00	2035	1100	302UJJAQ4A112A_A
14.2	3.39	123.10	2217	3000	306UJJAQ4A125A_A
14.0	1.73	125.10	2253	1550	304UJJAQ4A125A_A
12.3	2.94	142.30	2562	3000	306UJJAQ4A140A_A
12.2	1.50	143.90	2591	1550	304UJJAQ4A140A_A
11.4	2.72	153.50	2764	3000	306UJJAQ4A160A_A
11.4	1.40	154.20	2777	1550	304UJJAQ4A160A_A
9.76	1.21	179.40	3230	1550	304UJJAQ4A180A_A
9.56	2.28	183.10	3297	3000	306UJJAQ4A180A_A
9.00	2.15	194.30	3499	3000	306UJJAQ4A200A_A
8.96	1.11	195.20	3515	1550	304UJJAQ4A200A_A
7.99	1.91	219.00	3944	3000	306UJJAQ4A224A_A
7.71	3.68	227.00	4088	4000	307UJJAQ4A224A_A
7.14	3.41	245.10	4414	4000	307UJJAQ4A250A_A
6.92	1.65	252.90	4554	3000	306UJJAQ4A250A_A
6.29	1.50	278.30	5011	3000	306UJJAQ4A280A_A

Approx Output RPM	Service Factor	Exact Ratio	Actual Output Torque (lb-in)	Overhung Load (lb)	Drive Designation
6.09	2.91	287.40	5175	4000	307UJJAQ4A280A_A
5.68	1.36	308.20	5550	3000	306UJJAQ4A315A_A
5.60	2.67	312.90	5634	4000	307UJJAQ4A315A_A
5.10	1.22	343.30	6182	3000	306UJJAQ4A355A_A
4.68	2.23	374.10	6736	4000	307UJJAQ4A355A_A
4.54	1.08	385.50	6942	3000	306UJJAQ4A400A_A
4.25	2.03	411.70	7414	4000	307UJJAQ4A400A_A
4.23	3.44	414.10	7457	6100	308UJJAQ4A400A_A
3.84	1.83	455.90	8209	4000	307UJJAQ4A450A_A
3.82	3.11	458.40	8254	6100	308UJJAQ4A450A_A
3.45	1.65	507.90	9146	4000	307UJJAQ4A500A_A
3.43	2.79	510.80	9198	6100	308UJJAQ4A500A_A
3.07	1.47	570.30	10269	4000	307UJJAQ4A560A_A
3.05	2.49	573.50	10327	6100	308UJJAQ4A560A_A
2.76	1.32	634.70	11429	4000	307UJJAQ4A630A_A
2.74	2.23	638.30	11494	6100	308UJJAQ4A630A_A
2.47	1.18	710.00	12785	4000	307UJJAQ4A710A_A
2.45	2.00	713.90	12855	6100	308UJJAQ4A710A_A
2.38	3.67	735.80	13250	6700	309UJJAQ4A710A_A
2.14	3.30	819.30	14753	6700	309UJJAQ4A800A_A
2.12	1.01	825.30	14861	4000	307UJJAQ4A800A_A
2.11	1.72	829.90	14944	6100	308UJJAQ4A800A_A
1.93	2.98	906.30	16320	6700	309UJJAQ4A900A_A
1.89	1.54	924.60	16649	6100	308UJJAQ4A900A_A
1.83	1.49	954.00	17179	6100	308UJJAQ4A10CA_A
1.74	2.68	1007.00	18133	6700	309UJJAQ4A10CA_A
1.58	3.55	1106.00	19916	11200	310UJJAQ4A11CA_A
1.52	1.24	1149.00	20690	6100	308UJJAQ4A11CA_A

Motors are available from Rexnord or Rexnord distributors.

0.50 HP/56C Motor
Falk Part No. 10606587

Conforms to the following specifications:

C-Face motor less base, EPACT, Premium Efficient, rolled steel, TEFC, 1750 rpm, 208–230/460 Volts, 3 Phase, 60 Hz, NEMA B, 1.15 Service Factor.

Motors meeting other specifications are available upon request.

300UJ — Gearmotor Selection Table

0.75 HP/1750 RPM/56C Frame Motor

Approx Output RPM	Service Factor	Exact Ratio	Actual Output Torque (lb-in)	Overhung Load (lb)	Drive Designation	Approx Output RPM	Service Factor	Exact Ratio	Actual Output Torque (lb-in)	Overhung Load (lb)	Drive Designation
504	8.31	3.47	94	560	302UJAQ2A3.5A_A	7.14	2.27	245.10	6620	4000	307UJAQ4A250A_A
441	8.34	3.97	107	560	302UJAQ2A4.0A_A	6.92	1.10	252.90	6831	3000	306UJAQ4A250A_A
411	8.61	4.26	115	560	302UJAQ2A4.5A_A	6.29	1.00	278.30	7517	3000	306UJAQ4A280A_A
357	8.36	4.90	132	570	302UJAQ2A5.0A_A	6.05	1.21	289.06	7808	4000	307UJAQ3A280A_A
299	8.32	5.67	153	550	302UJAQ2A5.6A_A	6.03	3.27	290.23	7839	6100	308UJAQ3A280A_A
287	8.33	6.10	165	570	302UJAQ2A6.3A_A	5.60	1.78	312.90	8452	4000	307UJAQ4A315A_A
266	8.20	6.59	178	600	302UJAQ2A7.1A_A	5.38	2.92	325.39	8789	6100	308UJAQ3A315A_A
226	6.99	7.73	209	620	302UJAQ2A8.0A_A	4.68	1.49	374.10	10105	4000	307UJAQ4A355A_A
207	8.33	8.46	229	620	302UJAQ2A9.0A_A	4.65	2.53	376.20	10161	6100	308UJAQ4A355A_A
181	7.78	9.69	262	630	302UJAQ2A10.A_A	4.25	1.35	411.70	11120	4000	307UJAQ4A400A_A
168	7.25	10.39	281	660	302UJAQ2A11.A_A	4.23	2.29	414.10	11185	6100	308UJAQ4A400A_A
146	6.31	11.95	323	700	302UJAQ2A12.A_A	3.84	1.22	455.90	12314	4000	307UJAQ4A450A_A
127	5.45	13.82	373	760	302UJAQ2A14.A_A	3.82	2.07	458.40	12382	6100	308UJAQ4A450A_A
109	4.69	16.08	434	800	302UJAQ2A16.A_A	3.45	1.10	507.90	13719	4000	307UJAQ4A500A_A
92.7	3.99	18.87	510	850	302UJAQ2A18.A_A	3.43	1.86	510.80	13797	6100	308UJAQ4A500A_A
85.3	3.67	20.52	554	900	302UJAQ2A20.A_A	3.14	3.24	556.90	15042	6700	309UJAQ4A560A_A
71.3	3.07	24.55	663	1000	302UJAQ2A25.A_A	3.07	0.98	570.30	15404	4000	307UJAQ4A560A_A
64.8	2.79	27.02	730	1050	302UJAQ2A28.A_A	3.05	1.66	573.50	15491	6100	308UJAQ4A560A_A
58.5	2.52	29.91	808	1100	302UJAQ2A31.A_A	2.85	2.93	615.00	16612	6700	309UJAQ4A630A_A
46.8	2.01	37.42	1011	1100	302UJAQ2A35.A_A	2.74	1.49	638.30	17241	6100	308UJAQ4A630A_A
42.2	1.81	41.65	1125	1100	302UJAQ2A40.A_A	2.45	1.33	713.90	19283	6100	308UJAQ4A710A_A
42.0	1.81	41.65	1125	1100	302UJAQ2A40.A_A	2.38	2.45	735.80	19874	6700	309UJAQ4A710A_A
37.9	1.62	46.58	1258	1100	302UJAQ2A45.A_A	2.16	3.24	808.40	21835	11200	310UJAQ4A800A_A
37.6	1.62	46.58	1258	1100	302UJAQ2A45.A_A	2.14	2.20	819.30	22130	6700	309UJAQ4A800A_A
33.9	1.54	49.00	1324	1100	302UJAQ2A50.A_A	2.11	1.14	829.90	22416	6100	308UJAQ4A800A_A
32.3	1.39	54.15	1463	1100	302UJAQ2A56.A_A	1.94	2.91	900.10	24312	11200	310UJAQ4A900A_A
29.2	1.39	54.15	1463	1100	302UJAQ2A56.A_A	1.93	1.99	906.30	24480	6700	309UJAQ4A900A_A
29.0	1.25	60.33	1630	1100	302UJAQ2A63.A_A	1.89	1.03	924.60	24974	6100	308UJAQ4A900A_A
26.2	1.25	60.33	1630	1100	302UJAQ2A63.A_A	1.83	1.00	954.00	25768	6100	308UJAQ4A10CA_A
25.4	1.01	74.98	2025	1100	302UJAQ2A71.A_A	1.76	2.63	996.00	26903	11200	310UJAQ4A10CA_A
23.3	1.01	74.98	2025	1100	302UJAQ2A71.A_A	1.74	1.79	1007.00	27200	6700	309UJAQ4A10CA_A
22.5	0.91	83.24	2248	1100	302UJAQ2A80.A_A	1.58	2.37	1106.00	29874	11200	310UJAQ4A11CA_A
21.1	0.91	83.24	2248	1100	302UJAQ2A80.A_A						
20.4	3.25	85.68	2314	3000	306UJAQ2A90.A_A						
19.0	0.81	93.33	2521	1100	302UJAQ2A90.A_A						
17.5	2.79	99.85	2697	3000	306UJAQ4A100A_A						
17.2	1.42	101.80	2750	1550	304UJAQ4A100A_A						
16.9	0.98	103.33	2791	1550	304UJAQ2A100A_A						
16.5	2.47	106.33	2872	3000	306UJAQ2A100A_A						
16.4	2.60	107.00	2890	3000	306UJAQ4A112A_A						
16.2	1.33	108.10	2920	1550	304UJAQ4A112A_A						
14.2	2.26	123.10	3325	3000	306UJAQ4A125A_A						
14.0	1.15	125.10	3379	1550	304UJAQ4A125A_A						
12.3	1.96	142.30	3844	3000	306UJAQ4A140A_A						
12.2	1.00	143.90	3887	1550	304UJAQ4A140A_A						
11.4	1.81	153.50	4146	3000	306UJAQ4A160A_A						
10.7	3.41	163.58	4418	4000	307UJAQ3A160A_A						
9.67	3.08	180.96	4888	4000	307UJAQ3A180A_A						
9.56	1.52	183.10	4946	3000	306UJAQ4A180A_A						
9.00	1.43	194.30	5248	3000	306UJAQ4A200A_A						
8.71	2.77	201.03	5430	4000	307UJAQ3A200A_A						
7.99	1.27	219.00	5915	3000	306UJAQ4A224A_A						
7.51	1.21	232.92	6291	4000	307UJAQ3A224A_A						

Motors are available from Rexnord or Rexnord distributors.

0.75 HP/56C Motor
Falk Part No. 10606588

Conforms to the following specifications:

C-Face motor less base, EPACT, Premium Efficient, rolled steel, TEFC, 1750 rpm, 208–230/460 Volts, 3 Phase, 60 Hz, NEMA B, 1.15 Service Factor.

Motors meeting other specifications are available upon request.

300UJ — Gearmotor Selection Table

1.0 HP/1750 RPM/143TC Frame Motor

Approx Output RPM	Service Factor	Exact Ratio	Actual Output Torque (lb-in)	Overhung Load (lb)	Drive Designation
504	6.23	3.47	125	560	302UJAQ2A3.5A_B
441	6.25	3.97	143	560	302UJAQ2A4.0A_B
411	6.46	4.26	153	560	302UJAQ2A4.5A_B
357	6.27	4.90	176	570	302UJAQ2A5.0A_B
309	6.24	5.67	204	550	302UJAQ2A5.6A_B
287	6.24	6.10	220	570	302UJAQ2A6.3A_B
266	6.15	6.59	237	600	302UJAQ2A7.1A_B
226	5.25	7.73	278	620	302UJAQ2A8.0A_B
207	5.25	7.73	278	620	302UJAQ2A8.0A_B
181	5.83	9.69	349	630	302UJAQ2A10.A_B
168	5.44	10.39	374	660	302UJAQ2A11.A_B
146	4.73	11.95	430	700	302UJAQ2A12.A_B
127	4.09	13.82	498	760	302UJAQ2A14.A_B
109	3.51	16.08	579	800	302UJAQ2A16.A_B
92.7	3.00	18.87	680	850	302UJAQ2A18.A_B
85.3	2.75	20.52	739	900	302UJAQ2A20.A_B
71.3	2.30	24.55	884	1000	302UJAQ2A25.A_B
64.8	2.09	27.02	973	1050	302UJAQ2A28.A_B
58.5	1.89	29.91	1077	1100	302UJAQ2A31.A_B
58.5	3.61	29.92	1078	1550	304UJAQ2A28.A_B
52.9	3.27	33.11	1192	1550	304UJAQ2A31.A_B
47.4	2.93	36.89	1329	1550	304UJAQ2A35.A_B
46.8	1.51	37.42	1348	1100	302UJAQ2A35.A_B
42.2	2.61	41.43	1492	1550	304UJAQ2A40.A_B
42.0	1.36	41.65	1500	1100	302UJAQ2A40.A_B
37.9	2.34	46.12	1661	1550	304UJAQ2A45.A_B
37.6	1.21	46.58	1678	1100	302UJAQ2A45.A_B
33.9	2.10	51.57	1857	1550	304UJAQ2A50.A_B
32.3	1.04	54.15	1950	1100	302UJAQ2A56.A_B
29.2	1.80	59.95	2159	1550	304UJAQ2A56.A_B
29.1	3.47	60.18	2167	3000	306UJAQ2A56.A_B
26.3	3.14	66.57	2397	3000	306UJAQ2A63.A_B
26.2	1.62	66.79	2405	1550	304UJAQ2A63.A_B
25.4	1.30	68.94	2483	1550	304UJAQ2A71.A_B
23.7	2.82	73.95	2663	3000	306UJAQ2A71.A_B
22.5	2.68	77.94	2807	3000	306UJAQ2A80.A_B
21.1	1.07	83.01	2990	1550	304UJAQ2A80.A_B
20.4	2.44	85.68	3086	3000	306UJAQ2A90.A_B
17.5	2.09	99.85	3596	3000	306UJAQ4A100A_B
17.2	1.06	101.80	3666	1550	304UJAQ4A100A_B
16.5	1.85	106.33	3829	3000	306UJAQ2A100A_B
16.4	1.95	107.00	3854	3000	306UJAQ4A112A_B
16.2	1.00	108.10	3893	1550	304UJAQ4A112A_B
15.7	3.76	111.20	4005	4000	307UJAQ3A112A_B
14.3	3.40	122.80	4423	4000	307UJAQ3A125A_B
14.2	1.70	123.10	4433	3000	306UJAQ4A125A_B
12.3	1.47	142.30	5125	3000	306UJAQ4A140A_B
11.9	2.84	146.92	5291	4000	307UJAQ3A140A_B
11.4	1.36	153.50	5528	3000	306UJAQ4A160A_B
10.7	2.55	163.58	5891	4000	307UJAQ3A160A_B
9.67	2.31	180.96	6517	4000	307UJAQ3A180A_B
9.56	1.14	183.10	6594	3000	306UJAQ4A180A_B
9.12	3.71	191.86	6910	6100	308UJAQ3A200A_B

Approx Output RPM	Service Factor	Exact Ratio	Actual Output Torque (lb-in)	Overhung Load (lb)	Drive Designation
9.00	1.08	194.30	6998	3000	306UJAQ4A200A_B
8.71	2.08	201.03	7240	4000	307UJAQ3A200A_B
7.90	3.22	221.46	7976	6100	308UJAQ3A224A_B
7.51	1.24	232.92	8388	4000	307UJAQ3A224A_B
7.20	2.93	243.22	8759	6100	308UJAQ3A250A_B
7.14	1.70	245.10	8827	4000	307UJAQ4A250A_B
6.05	1.24	289.06	10410	4000	307UJAQ3A280A_B
6.03	2.46	290.23	10452	6100	308UJAQ3A280A_B
5.60	1.34	312.90	11269	4000	307UJAQ4A315A_B
5.38	2.19	325.39	11719	6100	308UJAQ3A315A_B
4.68	1.12	374.10	13473	4000	307UJAQ4A355A_B
4.65	1.89	376.20	13549	6100	308UJAQ4A355A_B
4.49	3.47	389.70	14035	6700	309UJAQ4A400A_B
4.25	1.01	411.70	14827	4000	307UJAQ4A400A_B
4.23	1.72	414.10	14914	6100	308UJAQ4A400A_B
3.97	3.06	441.30	15893	6700	309UJAQ4A450A_B
3.82	1.55	458.40	16509	6100	308UJAQ4A450A_B
3.64	2.81	481.20	17330	6700	309UJAQ4A500A_B
3.43	1.40	510.80	18396	6100	308UJAQ4A500A_B
3.31	3.72	528.70	19041	11200	310UJAQ4A560A_B
3.14	2.43	556.90	20056	6700	309UJAQ4A560A_B
3.05	1.24	573.50	20654	6100	308UJAQ4A560A_B
2.88	2.43	808.40	29114	11200	310UJAQ4A800A_B
2.86	3.21	611.80	22034	11200	310UJAQ4A630A_B
2.85	2.20	615.00	22149	6700	309UJAQ4A630A_B
2.74	1.12	638.30	22988	6100	308UJAQ4A630A_B
2.59	2.91	675.60	24331	11200	310UJAQ4A710A_B
2.45	1.00	713.90	25711	6100	308UJAQ4A710A_B
2.38	1.84	735.80	26499	6700	309UJAQ4A710A_B
2.14	1.65	819.30	29507	6700	309UJAQ4A800A_B
1.94	2.18	900.10	32416	11200	310UJAQ4A900A_B
1.93	1.49	906.30	32640	6700	309UJAQ4A900A_B
1.76	1.97	996.00	35870	11200	310UJAQ4A10CA_B
1.74	1.34	1007.00	36266	6700	309UJAQ4A10CA_B
1.62	3.40	1082.86	38998	19077	312UJAQ5A11CA_B
1.58	1.78	1106.00	39832	11200	310UJAQ4A11CA_B

Motors are available from Rexnord or Rexnord distributors.

1.0 HP/143TC Motor
Falk Part No. 10609014

Conforms to the following specifications:

C-Face motor less base, EPACT, Premium Efficient, rolled steel, TEFC, 1750 rpm, 208–230/460 Volts, 3 Phase, 60 Hz, NEMA B, 1.15 Service Factor.

Motors meeting other specifications are available upon request.

300UJ — Gearmotor Selection Table

1.5 HP/1750 RPM/145TC Frame Motor

Approx Output RPM	Service Factor	Exact Ratio	Actual Output Torque (lb-in)	Overhung Load (lb)	Drive Designation
504	4.15	3.47	187	560	302UJAQ2A3.5A_B
441	4.17	3.97	214	560	302UJAQ2A4.0A_B
411	4.31	4.26	230	560	302UJAQ2A4.5A_B
357	4.18	4.90	265	570	302UJAQ2A5.0A_B
309	4.16	5.67	306	550	302UJAQ2A5.6A_B
287	4.16	6.10	330	570	302UJAQ2A6.3A_B
266	4.10	6.59	356	600	302UJAQ2A7.1A_B
226	3.50	7.73	418	620	302UJAQ2A8.0A_B
207	4.16	8.46	457	620	302UJAQ2A9.0A_B
181	3.89	9.69	523	630	302UJAQ2A10.A_B
168	3.63	10.39	561	660	302UJAQ2A11.A_B
146	3.15	11.95	646	700	302UJAQ2A12.A_B
127	2.73	13.82	747	760	302UJAQ2A14.A_B
109	2.34	16.08	869	800	302UJAQ2A16.A_B
92.7	2.00	18.87	1019	850	302UJAQ2A18.A_B
85.3	1.84	20.52	1109	900	302UJAQ2A20.A_B
83.8	3.45	20.89	1129	1550	304UJAQ2A20.A_B
77.0	3.17	22.72	1227	1550	304UJAQ2A22.A_B
71.3	1.53	24.55	1326	1000	302UJAQ2A25.A_B
64.8	1.39	27.02	1460	1050	302UJAQ2A28.A_B
64.4	2.65	27.18	1468	1550	304UJAQ2A25.A_B
58.5	1.26	29.91	1616	1100	302UJAQ2A31.A_B
58.5	2.41	29.92	1616	1550	304UJAQ2A28.A_B
52.9	2.18	33.11	1789	1550	304UJAQ2A31.A_B
47.4	1.95	36.89	1993	1550	304UJAQ2A35.A_B
46.8	1.01	37.42	2021	1100	302UJAQ2A35.A_B
42.8	3.40	40.91	2210	3000	306UJAQ2A40.A_B
42.2	1.74	41.43	2238	1550	304UJAQ2A40.A_B
38.7	1.56	46.12	2491	1550	304UJAQ2A45.A_B
37.9	1.56	46.12	2491	1550	304UJAQ2A45.A_B
33.9	1.40	51.57	2786	1550	304UJAQ2A50.A_B
32.4	2.58	54.05	2920	3000	306UJAQ2A50.A_B
29.2	1.20	59.95	3239	1550	304UJAQ2A56.A_B
29.1	2.31	60.18	3251	3000	306UJAQ2A56.A_B
26.3	2.09	66.57	3596	3000	306UJAQ2A63.A_B
26.2	1.08	66.79	3608	1550	304UJAQ2A63.A_B
23.7	1.88	73.95	3995	3000	306UJAQ2A71.A_B
23.0	3.56	75.97	4104	4000	307UJAQ2A71.A_B
22.5	3.58	77.80	4203	4000	307UJAQ3A80.A_B
22.5	1.79	77.94	4210	3000	306UJAQ2A80.A_B
20.4	1.63	85.68	4629	3000	306UJAQ2A90.A_B
19.9	3.16	88.11	4760	4000	307UJAQ3A90.A_B
18.2	2.90	96.08	5190	4000	307UJAQ3A100A_B
16.5	1.23	106.33	5744	3000	306UJAQ2A100A_B
16.4	1.30	107.00	5780	3000	306UJAQ4A112A_B
15.7	2.50	111.20	6007	4000	307UJAQ3A112A_B
14.3	2.27	122.80	6634	4000	307UJAQ3A125A_B
14.2	1.13	123.10	6650	3000	306UJAQ4A125A_B
13.5	3.66	129.77	7010	6100	308UJAQ3A125A_B
12.6	3.42	138.87	7502	6100	308UJAQ3A140A_B
12.3	0.98	142.30	7687	3000	306UJAQ4A140A_B
11.9	1.90	146.92	7937	4000	307UJAQ3A140A_B
11.3	3.06	155.10	8379	6100	308UJAQ3A160A_B

Motors are available from Rexnord or Rexnord distributors.

1.5 HP/145TC Motor
Falk Part No. 10609015

Conforms to the following specifications:

C-Face motor less base, EPACT, Premium Efficient, rolled steel, TEFC, 1750 rpm, 208–230/460 Volts, 3 Phase, 60 Hz, NEMA B, 1.15 Service Factor.

Motors meeting other specifications are available upon request.

Approx Output RPM	Service Factor	Exact Ratio	Actual Output Torque (lb-in)	Overhung Load (lb)	Drive Designation
10.7	1.70	163.58	8837	4000	307UJAQ3A160A_B
9.89	2.68	176.96	9560	6100	308UJAQ3A180A_B
9.67	1.54	180.96	9776	4000	307UJAQ3A180A_B
9.12	2.48	191.86	10365	6100	308UJAQ3A200A_B
8.71	1.39	201.03	10860	4000	307UJAQ3A200A_B
7.90	2.15	221.46	11964	6100	308UJAQ3A224A_B
7.51	1.22	232.92	12583	4000	307UJAQ3A224A_B
7.20	1.95	243.22	13139	6100	308UJAQ3A250A_B
7.14	1.14	245.10	13241	4000	307UJAQ4A250A_B
6.42	3.31	272.40	14715	6700	309UJAQ4A280A_B
6.03	1.64	290.23	15679	6100	308UJAQ3A280A_B
5.49	2.83	318.60	17211	6700	309UJAQ4A315A_B
5.38	1.46	325.39	17578	6100	308UJAQ3A315A_B
5.10	2.63	343.10	18535	6700	309UJAQ4A355A_B
4.65	1.26	376.20	20323	6100	308UJAQ4A355A_B
4.64	3.48	376.90	20361	11200	310UJAQ4A400A_B
4.49	2.31	389.70	21052	6700	309UJAQ4A400A_B
4.23	1.15	414.10	22370	6100	308UJAQ4A400A_B
4.09	3.06	428.10	23127	11200	310UJAQ4A450A_B
3.97	2.04	441.30	23840	6700	309UJAQ4A450A_B
3.82	1.04	458.40	24763	6100	308UJAQ4A450A_B
3.64	1.87	481.20	25995	6700	309UJAQ4A500A_B
3.61	2.70	484.80	26190	11200	310UJAQ4A500A_B
3.31	2.48	528.70	28561	11200	310UJAQ4A560A_B
3.14	1.62	556.90	30085	6700	309UJAQ4A560A_B
2.88	1.62	808.40	43671	11200	310UJAQ4A800A_B
2.86	2.14	611.80	33050	11200	310UJAQ4A630A_B
2.85	1.47	615.00	33223	6700	309UJAQ4A630A_B
2.59	1.94	675.60	36497	11200	310UJAQ4A710A_B
2.50	3.51	700.06	37818	19077	312UJAQ5A710A_B
2.38	1.22	735.80	39749	6700	309UJAQ4A710A_B
2.29	3.22	763.39	41239	19077	312UJAQ5A800A_B
2.14	1.10	819.30	44260	6700	309UJAQ4A800A_B
1.98	2.78	883.63	47735	19077	312UJAQ5A900A_B
1.94	1.46	900.10	48625	11200	310UJAQ4A900A_B
1.93	0.99	906.30	48960	6700	309UJAQ4A900A_B
1.83	2.57	956.13	51652	19077	312UJAQ5A10CA_B
1.76	1.32	996.00	53805	11200	310UJAQ4A10CA_B
1.62	2.27	1082.86	58498	19077	312UJAQ5A11CA_B
1.58	1.18	1106.00	59748	11200	310UJAQ4A11CA_B

300UJ — Gearmotor Selection Table

2.0 HP/1750 RPM/145TC Frame Motor

Approx Output RPM	Service Factor	Exact Ratio	Actual Output Torque (lb-in)	Overhung Load (lb)	Drive Designation	Approx Output RPM	Service Factor	Exact Ratio	Actual Output Torque (lb-in)	Overhung Load (lb)	Drive Designation
504	3.12	3.47	250	560	302UJAQ2A3.5A_B	15.8	3.22	110.51	7960	6100	308UJAQ3A112A_B
441	3.13	3.97	286	560	302UJAQ2A4.0A_B	15.7	1.88	111.20	8010	4000	307UJAQ3A112A_B
411	3.23	4.26	307	560	302UJAQ2A4.5A_B	14.3	1.70	122.80	8845	4000	307UJAQ3A125A_B
357	3.13	4.90	353	570	302UJAQ2A5.0A_B	13.5	2.75	129.77	9347	6100	308UJAQ3A125A_B
309	3.12	5.67	408	550	302UJAQ2A5.6A_B	12.6	2.57	138.87	10003	6100	308UJAQ3A140A_B
287	3.12	6.10	439	570	302UJAQ2A6.3A_B	11.9	1.42	146.92	10582	4000	307UJAQ3A140A_B
266	3.08	6.59	475	600	302UJAQ2A7.1A_B	11.3	2.30	155.10	11172	6100	308UJAQ3A160A_B
230	3.56	7.60	547	1550	304UJAQ2A7.1A_B	10.7	1.28	163.58	11782	4000	307UJAQ3A160A_B
226	2.62	7.73	557	620	302UJAQ2A8.0A_B	9.89	2.01	176.96	12746	6100	308UJAQ3A180A_B
214	3.30	8.19	590	1550	304UJAQ2A8.0A_B	9.67	1.15	180.96	13034	4000	307UJAQ3A180A_B
207	3.12	8.46	609	620	302UJAQ2A9.0A_B	9.12	1.86	191.86	13819	6100	308UJAQ3A200A_B
181	2.92	9.69	698	630	302UJAQ2A10.A_B	8.71	1.04	201.03	14480	4000	307UJAQ3A200A_B
168	2.72	10.39	748	660	302UJAQ2A11.A_B	7.90	1.61	221.46	15951	6100	308UJAQ3A224A_B
146	2.36	11.95	861	700	302UJAQ2A12.A_B	7.20	1.47	243.22	17519	6100	308UJAQ3A250A_B
127	2.04	13.82	995	760	302UJAQ2A14.A_B	6.42	2.48	272.40	19621	6700	309UJAQ4A280A_B
114	3.53	15.30	1102	1550	304UJAQ2A14.A_B	6.26	3.52	279.40	20125	11200	310UJAQ4A280A_B
109	1.76	16.08	1158	800	302UJAQ2A16.A_B	6.03	1.23	290.23	20905	6100	308UJAQ3A280A_B
106	3.28	16.49	1188	1550	304UJAQ2A16.A_B	5.85	3.28	299.30	21558	11200	310UJAQ4A315A_B
98.3	3.04	17.80	1282	1550	304UJAQ2A18.A_B	5.49	2.12	318.60	22948	6700	309UJAQ4A315A_B
92.7	1.50	18.87	1359	850	302UJAQ2A18.A_B	5.38	1.10	325.39	23437	6100	308UJAQ3A315A_B
85.3	1.38	20.52	1478	900	302UJAQ2A20.A_B	5.10	1.97	343.10	24713	6700	309UJAQ4A355A_B
83.8	2.59	20.89	1505	1550	304UJAQ2A20.A_B	5.00	2.81	350.00	25210	11200	310UJAQ4A355A_B
77.0	2.38	22.72	1636	1550	304UJAQ2A22.A_B	4.64	2.61	376.90	27148	11200	310UJAQ4A400A_B
71.3	1.15	24.55	1768	1000	302UJAQ2A25.A_B	4.49	1.73	389.70	28070	6700	309UJAQ4A400A_B
64.8	1.05	27.02	1946	1050	302UJAQ2A28.A_B	4.09	2.30	428.10	30835	11200	310UJAQ4A450A_B
64.4	1.99	27.18	1958	1550	304UJAQ2A25.A_B	3.97	1.53	441.30	31786	6700	309UJAQ4A450A_B
61.1	3.65	28.62	2061	3000	306UJAQ2A28.A_B	3.64	1.40	481.20	34660	6700	309UJAQ4A500A_B
58.5	1.81	29.92	2155	1550	304UJAQ2A28.A_B	3.61	2.03	484.80	34919	11200	310UJAQ4A500A_B
54.0	3.22	32.41	2334	3000	306UJAQ2A31.A_B	3.46	3.65	505.37	36401	19077	312UJAQ5A500A_B
52.9	1.63	33.11	2385	1550	304UJAQ2A31.A_B	3.31	1.86	528.70	38082	11200	310UJAQ4A560A_B
49.5	2.96	35.34	2545	3000	306UJAQ2A35.A_B	3.21	3.39	544.34	39208	19077	312UJAQ5A560A_B
47.4	1.47	36.89	2657	1550	304UJAQ2A35.A_B	3.14	1.21	556.90	40113	6700	309UJAQ4A560A_B
42.8	2.55	40.91	2947	3000	306UJAQ2A40.A_B	2.86	1.61	611.80	44067	11200	310UJAQ4A630A_B
42.2	1.30	41.43	2984	1550	304UJAQ2A40.A_B	2.85	1.10	615.00	44298	6700	309UJAQ4A630A_B
38.7	2.31	45.17	3254	3000	306UJAQ2A45.A_B	2.83	2.98	618.13	44523	19077	312UJAQ5A630A_B
37.9	1.17	46.12	3322	1550	304UJAQ2A45.A_B	2.59	1.45	675.60	48663	11200	310UJAQ4A710A_B
34.5	3.63	50.79	3658	4000	307UJAQ3A50.A_B	2.50	2.63	700.06	50424	19077	312UJAQ5A710A_B
33.9	1.05	51.57	3715	1550	304UJAQ2A50.A_B	2.29	2.41	763.39	54986	19077	312UJAQ5A800A_B
32.4	1.93	54.05	3893	3000	306UJAQ2A50.A_B	2.16	1.22	808.40	58228	11200	310UJAQ4A800A_B
30.8	3.68	56.78	4090	4000	307UJAQ2A56.A_B	1.98	2.09	883.63	63647	19077	312UJAQ5A900A_B
29.1	1.74	60.18	4335	3000	306UJAQ2A56.A_B	1.94	1.09	900.10	64833	11200	310UJAQ4A900A_B
26.3	1.57	66.57	4795	3000	306UJAQ2A63.A_B	1.83	1.93	956.13	68869	19077	312UJAQ5A10CA_B
25.8	3.08	67.76	4881	4000	307UJAQ2A63.A_B	1.62	1.70	1082.86	77997	19077	312UJAQ5A11CA_B
25.5	2.98	68.51	4935	4000	307UJAQ3A71.A_B						
23.7	1.41	73.95	5327	3000	306UJAQ2A71.A_B						
23.0	2.67	75.97	5472	4000	307UJAQ2A71.A_B						
22.5	2.68	77.80	5604	4000	307UJAQ3A80.A_B						
22.5	1.34	77.94	5614	3000	306UJAQ2A80.A_B						
20.4	1.22	85.68	6171	3000	306UJAQ2A90.A_B						
19.9	2.37	88.11	6346	4000	307UJAQ3A90.A_B						
18.2	2.17	96.08	6921	4000	307UJAQ3A100A_B						
18.1	3.69	96.48	6949	6100	308UJAQ3A100A_B						
17.5	1.05	99.85	7192	3000	306UJAQ4A100A_B						

Motors are available from Rexnord or Rexnord distributors.

2.0 HP/145TC Motor
Falk Part No. 10609016

Conforms to the following specifications:

C-Face motor less base, EPACT, Premium Efficient, rolled steel, TEFC, 1750 rpm, 208–230/460 Volts, 3 Phase, 60 Hz, NEMA B, 1.15 Service Factor.

Motors meeting other specifications are available upon request.

300UJ — Gearmotor Selection Table

3.0 HP/1750 RPM/182TC Frame Motor

Approx Output RPM	Service Factor	Exact Ratio	Actual Output Torque (lb-in)	Overhung Load (lb)	Drive Designation
504	2.08	3.47	375	560	302UJAQ2A3.5A_C
441	2.08	3.97	429	560	302UJAQ2A4.0A_C
411	2.15	4.26	460	560	302UJAQ2A4.5A_C
357	2.09	4.90	529	570	302UJAQ2A5.0A_C
328	3.38	5.33	576	1550	304UJAQ2A5.0A_C
309	2.08	5.67	613	550	302UJAQ2A5.6A_C
306	3.16	5.71	617	1550	304UJAQ2A5.6A_C
287	2.08	6.10	659	570	302UJAQ2A6.3A_C
266	2.74	6.57	710	1550	304UJAQ2A6.3A_C
266	2.05	6.59	712	600	302UJAQ2A7.1A_C
230	2.37	7.60	821	1550	304UJAQ2A7.1A_C
226	1.75	7.73	835	620	302UJAQ2A8.0A_C
214	2.20	8.19	885	1550	304UJAQ2A8.0A_C
207	2.08	8.46	914	620	302UJAQ2A9.0A_C
181	1.94	9.69	1047	630	302UJAQ2A10.A_C
168	1.81	10.39	1123	660	302UJAQ2A11.A_C
163	3.32	10.73	1159	1550	304UJAQ2A10.A_C
152	3.13	11.50	1242	1550	304UJAQ2A11.A_C
146	1.58	11.95	1291	700	302UJAQ2A12.A_C
132	2.72	13.23	1429	1550	304UJAQ2A12.A_C
127	1.36	13.82	1493	760	302UJAQ2A14.A_C
114	2.36	15.30	1653	1550	304UJAQ2A14.A_C
109	1.17	16.08	1737	800	302UJAQ2A16.A_C
106	2.19	16.49	1782	1550	304UJAQ2A16.A_C
98.3	2.02	17.80	1923	1550	304UJAQ2A18.A_C
92.7	1.00	18.87	2039	850	302UJAQ2A18.A_C
87.5	3.48	20.01	2162	3000	306UJAQ2A20.A_C
83.8	1.73	20.89	2257	1550	304UJAQ2A20.A_C
77.0	1.59	22.72	2455	1550	304UJAQ2A22.A_C
74.8	2.98	23.40	2528	3000	306UJAQ2A22.A_C
69.4	2.76	25.20	2723	3000	306UJAQ2A25.A_C
64.4	1.33	27.18	2937	1550	304UJAQ2A25.A_C
61.1	2.43	28.62	3092	3000	306UJAQ2A28.A_C
58.5	1.20	29.92	3233	1550	304UJAQ2A28.A_C
54.0	2.15	32.41	3502	3000	306UJAQ2A31.A_C
54.0	3.66	32.42	3503	3900	307UJAQ2A31.A_C
52.9	1.09	33.11	3577	1550	304UJAQ2A31.A_C
49.5	1.97	35.34	3818	3000	306UJAQ2A35.A_C
48.8	3.09	35.83	3871	4000	307UJAQ3A35.A_C
48.3	3.42	36.21	3912	4000	307UJAQ2A35.A_C
47.4	0.98	36.89	3986	1550	304UJAQ2A35.A_C
42.8	1.70	40.91	4420	3000	306UJAQ2A40.A_C
42.4	3.11	41.31	4463	4000	307UJAQ2A40.A_C
42.3	2.77	41.39	4472	4000	307UJAQ3A40.A_C
39.1	2.96	44.79	4839	4000	307UJAQ2A45.A_C
38.7	1.54	45.17	4880	3000	306UJAQ2A45.A_C
38.3	2.61	45.75	4943	4000	307UJAQ3A45.A_C
34.5	2.42	50.79	5487	4000	307UJAQ3A50.A_C
33.8	2.69	51.70	5586	4000	307UJAQ2A50.A_C
32.4	1.29	54.05	5840	3000	306UJAQ2A50.A_C
30.8	2.45	56.78	6135	4000	307UJAQ2A56.A_C
29.1	1.16	60.18	6502	3000	306UJAQ2A56.A_C
26.3	1.05	66.57	7192	3000	306UJAQ2A63.A_C
25.8	2.06	67.76	7321	4000	307UJAQ2A63.A_C
24.9	3.27	70.17	7581	6100	308UJAQ3A71.A_C
23.0	1.78	75.97	8208	4000	307UJAQ2A71.A_C
22.7	3.08	77.21	8342	6100	308UJAQ3A80.A_C
22.5	1.79	77.80	8406	4000	307UJAQ3A80.A_C

Approx Output RPM	Service Factor	Exact Ratio	Actual Output Torque (lb-in)	Overhung Load (lb)	Drive Designation
20.9	3.48	63.59	6870	6100	308UJAQ3A63.A_C
20.1	2.73	86.98	9398	6100	308UJAQ3A90.A_C
19.9	1.58	88.11	9520	4000	307UJAQ3A90.A_C
18.2	1.45	96.08	10381	4000	307UJAQ3A100A_C
18.1	2.46	96.48	10424	6100	308UJAQ3A100A_C
15.8	2.15	110.51	11940	6100	308UJAQ3A112A_C
15.7	1.25	111.20	12014	4000	307UJAQ3A112A_C
14.3	1.13	122.80	13268	4000	307UJAQ3A125A_C
14.0	3.60	125.03	13509	6700	309UJAQ3A125A_C
13.5	1.83	129.77	14021	6100	308UJAQ3A125A_C
12.6	1.71	138.87	15004	6100	308UJAQ3A140A_C
11.9	3.07	146.82	15863	6700	309UJAQ3A140A_C
11.3	1.53	155.10	16757	6100	308UJAQ3A160A_C
11.1	2.87	157.12	16976	6700	309UJAQ3A160A_C
10.0	2.57	175.48	18959	6700	309UJAQ3A180A_C
9.89	1.34	176.96	19119	6100	308UJAQ3A180A_C
9.64	3.61	181.46	19605	11200	310UJAQ3A180A_C
9.12	1.24	191.86	20729	6100	308UJAQ3A200A_C
8.74	2.25	200.21	21631	6700	309UJAQ3A200A_C
8.45	3.17	207.03	22368	11200	310UJAQ3A200A_C
8.06	2.08	217.07	23453	6700	309UJAQ3A224A_C
7.90	1.07	221.46	23927	6100	308UJAQ3A224A_C
7.80	2.92	224.46	24251	11200	310UJAQ3A224A_C
7.20	0.98	243.22	26278	6100	308UJAQ3A250A_C
6.98	1.80	250.56	27071	6700	309UJAQ3A250A_C
6.75	2.53	259.09	27993	11200	310UJAQ3A250A_C
6.36	1.64	275.17	29730	6700	309UJAQ3A280A_C
6.15	2.30	284.55	30744	11200	310UJAQ3A280A_C
5.85	2.19	299.30	32337	11200	310UJAQ4A315A_C
5.33	1.21	328.36	35477	6700	309UJAQ3A315A_C
5.15	1.21	339.55	36686	11200	310UJAQ3A355A_C
4.81	3.38	363.52	39276	19077	312UJAQ5A355A_C
4.75	1.21	368.15	39776	6700	309UJAQ3A355A_C
4.60	1.21	380.68	41130	11200	310UJAQ3A400A_C
4.49	1.16	389.70	42104	6700	309UJAQ4A400A_C
4.34	3.04	403.53	43599	19077	312UJAQ5A400A_C
4.09	1.53	428.10	46253	11200	310UJAQ4A450A_C
4.05	2.84	432.19	46695	19077	312UJAQ5A450A_C
3.97	1.02	441.30	47679	6700	309UJAQ4A450A_C
3.61	1.35	484.80	52379	11200	310UJAQ4A500A_C
3.46	2.43	505.37	54602	19077	312UJAQ5A500A_C
3.31	1.24	528.70	57122	11200	310UJAQ4A560A_C
3.21	2.26	544.34	58812	19077	312UJAQ5A560A_C
2.86	1.07	611.80	66101	11200	310UJAQ4A630A_C
2.83	1.99	618.13	66785	19077	312UJAQ5A630A_C
2.59	0.97	675.60	72994	11200	310UJAQ4A710A_C
2.50	1.76	700.06	75636	19077	312UJAQ5A710A_C
2.29	1.61	763.39	82479	19077	312UJAQ5A800A_C
1.98	1.39	883.63	95470	19077	312UJAQ5A900A_C
1.83	1.29	956.13	103303	19077	312UJAQ5A10CA_C
1.62	1.13	1082.86	116995	19077	312UJAQ5A11CA_C

Motors are available from Rexnord or Rexnord distributors.

3.0 HP/182TC Motor
Falk Part No. 10606592

Conforms to the following specifications:

C-Face motor less base, EPACT, Premium Efficient, rolled steel, TEFC, 1750 rpm, 208–230/460 Volts, 3 Phase, 60 Hz, NEMA B, 1.15 Service Factor.

Motors meeting other specifications are available upon request.

300UJ — Gearmotor Selection Table

5.0 HP/1750 RPM/184TC Frame Motor

Approx Output RPM	Service Factor	Exact Ratio	Actual Output Torque (lb-in)	Overhung Load (lb)	Drive Designation	Approx Output RPM	Service Factor	Exact Ratio	Actual Output Torque (lb-in)	Overhung Load (lb)	Drive Designation
504	1.25	3.47	625	560	302UJAQ2A3.5A_C	33.8	1.62	51.70	9310	4000	307UJAQ2A50.A_C
441	1.25	3.97	715	560	302UJAQ2A4.0A_C	33.5	2.73	52.18	9396	5800	308UJAQ2A50.A_C
411	1.29	4.26	767	560	302UJAQ2A4.5A_C	30.8	1.47	56.78	10224	4000	307UJAQ2A56.A_C
376	2.33	4.65	837	1550	304UJAQ2A4.5A_C	30.2	2.29	58.03	10450	6000	308UJAQ2A56.A_C
357	1.25	4.90	882	570	302UJAQ2A5.0A_C	28.4	3.86	61.68	11107	6700	309UJAQ2A63.A_C
328	2.03	5.33	960	1550	304UJAQ2A5.0A_C	27.5	2.09	63.59	11451	6100	308UJAQ3A63.A_C
313	3.64	5.60	1008	2300	306UJAQ2A5.6A_C	25.8	1.23	67.76	12202	4000	307UJAQ2A63.A_C
309	1.25	5.67	1021	550	302UJAQ2A5.6A_C	25.6	3.23	68.49	12333	6700	309UJAQ2A71.A_C
306	1.89	5.71	1028	1550	304UJAQ2A5.6A_C	24.9	1.96	70.17	12636	6100	308UJAQ3A71.A_C
287	1.25	6.10	1098	570	302UJAQ2A6.3A_C	24.3	3.76	71.94	12954	6700	309UJAQ3A71.A_C
283	3.30	6.19	1115	2400	306UJAQ2A6.3A_C	23.0	1.07	75.97	13680	4000	307UJAQ2A71.A_C
266	1.65	6.57	1183	1550	304UJAQ2A6.3A_C	22.7	1.85	77.21	13903	6100	308UJAQ3A80.A_C
266	1.23	6.59	1187	600	302UJAQ2A7.1A_C	22.5	1.07	77.80	14010	4000	307UJAQ3A80.A_C
255	2.97	6.87	1237	2400	306UJAQ2A7.1A_C	22.0	3.41	79.38	14294	6700	309UJAQ3A80.A_C
230	1.42	7.60	1369	1550	304UJAQ2A7.1A_C	20.1	1.64	86.98	15663	6100	308UJAQ3A90.A_C
214	1.32	8.19	1475	1550	304UJAQ2A8.0A_C	20.0	3.09	87.35	15729	6700	309UJAQ3A90.A_C
207	1.25	8.46	1523	620	302UJAQ2A9.0A_C	18.1	1.48	96.48	17373	6100	308UJAQ3A100A_C
187	2.26	9.36	1685	1550	304UJAQ2A9.0A_C	17.8	2.75	98.40	17719	6700	309UJAQ3A100A_C
181	1.17	9.69	1745	630	302UJAQ2A10.A_C	17.2	3.86	101.75	18322	11200	310UJAQ3A100A_C
168	1.09	10.39	1871	660	302UJAQ2A11.A_C	16.0	2.48	109.15	19655	6700	309UJAQ3A112A_C
167	3.98	10.49	1889	2650	306UJAQ2A10.A_C	15.8	1.29	110.51	19900	6100	308UJAQ3A112A_C
163	1.99	10.73	1932	1550	304UJAQ2A10.A_C	15.5	3.48	112.87	20325	11200	310UJAQ3A112A_C
152	1.88	11.50	2071	1550	304UJAQ2A11.A_C	14.0	2.16	125.03	22514	6700	309UJAQ3A125A_C
146	3.48	12.01	2163	2750	306UJAQ2A11.A_C	13.5	3.04	129.29	23281	11200	310UJAQ3A125A_C
133	3.17	13.18	2373	2900	306UJAQ2A12.A_C	13.5	1.10	129.77	23368	6100	308UJAQ3A125A_C
132	1.63	13.23	2382	1550	304UJAQ2A12.A_C	11.9	1.84	146.82	26438	6700	309UJAQ3A140A_C
118	3.77	14.85	2674	3100	307UJAQ2A14.A_C	11.5	2.59	151.82	27338	11200	310UJAQ3A140A_C
115	2.74	15.23	2742	2900	306UJAQ2A14.A_C	11.1	1.72	157.12	28293	6700	309UJAQ3A160A_C
114	1.41	15.30	2755	1550	304UJAQ2A14.A_C	10.8	2.42	162.47	29256	11200	310UJAQ3A160A_C
107	3.51	16.38	2950	3200	307UJAQ2A16.A_C	10.0	1.54	175.48	31599	6700	309UJAQ3A180A_C
106	1.31	16.49	2969	1550	304UJAQ2A16.A_C	9.64	2.17	181.46	32676	11200	310UJAQ3A180A_C
104	2.48	16.83	3031	2950	306UJAQ2A16.A_C	8.74	1.35	200.21	36052	6700	309UJAQ3A200A_C
98.3	1.21	17.80	3205	1550	304UJAQ2A18.A_C	8.65	3.64	202.42	36450	19077	312UJAQ5A200A_C
97.1	3.30	18.03	3247	3400	307UJAQ2A18.A_C	8.45	1.90	207.03	37280	11200	310UJAQ3A200A_C
93.7	2.24	18.68	3364	3000	306UJAQ2A18.A_C	8.06	1.25	217.07	39088	6700	309UJAQ3A224A_C
87.5	2.09	20.01	3603	3000	306UJAQ2A20.A_C	7.80	1.75	224.46	40419	11200	310UJAQ3A224A_C
86.2	3.02	20.31	3657	3500	307UJAQ2A20.A_C	7.72	3.25	226.65	40813	19077	312UJAQ5A224A_C
77.7	2.84	22.52	4055	3500	307UJAQ2A22.A_C	6.98	1.08	250.56	45119	6700	309UJAQ3A250A_C
74.8	1.79	23.40	4214	3000	306UJAQ2A22.A_C	6.75	1.52	259.09	46655	11200	310UJAQ3A250A_C
69.4	1.66	25.20	4538	3000	306UJAQ2A25.A_C	6.74	2.84	259.50	46729	19077	312UJAQ5A250A_C
67.8	2.57	25.80	4646	3700	307UJAQ2A25.A_C	6.15	1.38	284.55	51239	11200	310UJAQ3A280A_C
61.1	1.46	28.62	5154	3000	306UJAQ2A28.A_C	6.15	2.59	284.71	51268	19077	312UJAQ5A280A_C
57.8	2.27	30.30	5456	3800	307UJAQ2A28.A_C	5.85	1.31	299.30	53895	11200	310UJAQ4A315A_C
54.8	3.88	31.91	5746	5100	308UJAQ2A31.A_C	5.32	2.24	328.84	59215	19077	312UJAQ5A315A_C
54.0	1.29	32.41	5836	3000	306UJAQ2A31.A_C	5.15	1.32	339.55	61143	11200	310UJAQ3A355A_C
54.0	2.20	32.42	5838	3900	307UJAQ2A31.A_C	4.81	2.03	363.52	65460	19077	312UJAQ5A355A_C
51.9	3.21	33.69	6067	6100	308UJAQ3A35.A_C	4.34	1.83	403.53	72664	19077	312UJAQ5A400A_C
49.5	1.18	35.34	6364	3000	306UJAQ2A35.A_C	4.05	1.71	432.19	77825	19077	312UJAQ5A450A_C
48.8	1.85	35.83	6452	4000	307UJAQ3A35.A_C	3.46	1.46	505.37	91003	19077	312UJAQ5A500A_C
48.3	2.05	36.21	6520	4000	307UJAQ2A35.A_C	3.21	1.35	544.34	98020	19077	312UJAQ5A560A_C
47.8	3.56	36.58	6587	5300	308UJAQ2A35.A_C	2.83	1.19	618.13	111308	19077	312UJAQ5A630A_C
46.3	2.99	37.78	6803	6100	308UJAQ3A40.A_C	2.50	1.05	700.06	126061	19077	312UJAQ5A710A_C
44.1	3.41	39.65	7140	5400	308UJAQ2A40.A_C						
42.4	1.87	41.31	7439	4000	307UJAQ2A40.A_C						
40.2	2.71	43.49	7831	6100	308UJAQ3A45.A_C						
39.1	1.78	44.79	8065	4000	307UJAQ2A45.A_C						
37.4	3.02	46.78	8424	5700	308UJAQ2A45.A_C						
35.5	2.49	49.30	8878	6100	308UJAQ3A50.A_C						

Motors are available from Rexnord or Rexnord distributors.

5.0 HP/184TC Motor
Falk Part No. 10606593

Conforms to the following specifications:

C-Face motor less base, EPACT, Premium Efficient, rolled steel, TEFC, 1750 rpm, 208–230/460 Volts, 3 Phase, 60 Hz, NEMA B, 1.15 Service Factor.

Motors meeting other specifications are available upon request.

300UJ — Gearmotor Selection Table

7.5 HP/1750 RPM/213TC Frame Motor

Approx Output RPM	Service Factor	Exact Ratio	Actual Output Torque (lb-in)	Overhung Load (lb)	Drive Designation	Approx Output RPM	Service Factor	Exact Ratio	Actual Output Torque (lb-in)	Overhung Load (lb)	Drive Designation
507	3.12	3.45	932	2050	306UJAQ2A3.5A_D	30.2	1.52	58.03	15674	6000	308UJAQ2A56.A_D
453	3.13	3.86	1043	2050	306UJAQ2A4.0A_D	28.4	2.58	61.68	16660	6700	309UJAQ2A63.A_D
396	3.08	4.42	1194	2100	306UJAQ2A4.5A_D	27.5	1.39	63.59	17176	6100	308UJAQ3A63.A_D
361	2.80	4.85	1310	2200	306UJAQ2A5.0A_D	25.6	2.15	68.49	18500	6700	309UJAQ2A71.A_D
313	2.43	5.60	1513	2300	306UJAQ2A5.6A_D	24.9	1.31	70.17	18953	6100	308UJAQ3A71.A_D
283	2.20	6.19	1672	2400	306UJAQ2A6.3A_D	24.3	2.50	71.94	19432	6700	309UJAQ3A71.A_D
258	3.53	6.77	1829	2650	307UJAQ2A6.3A_D	23.5	3.52	74.39	20093	11200	310UJAQ3A71.A_D
255	1.98	6.87	1856	2400	306UJAQ2A7.1A_D	22.7	1.23	77.21	20855	6100	308UJAQ3A80.A_D
217	3.00	8.07	2180	2500	306UJAQ2A8.0A_D	22.0	2.27	79.38	21441	6700	309UJAQ3A80.A_D
198	3.53	8.82	2382	2800	307UJAQ2A9.0A_D	21.3	3.19	82.09	22173	11200	310UJAQ3A80.A_D
187	2.80	9.37	2531	2500	306UJAQ2A9.0A_D	20.1	1.09	86.98	23494	6100	308UJAQ3A90.A_D
172	3.23	10.15	2742	2800	307UJAQ2A10.A_D	20.0	2.06	87.35	23594	6700	309UJAQ3A90.A_D
167	2.65	10.49	2833	2650	306UJAQ2A10.A_D	19.4	2.90	90.33	24399	11200	310UJAQ3A90.A_D
152	3.02	11.51	3109	2900	307UJAQ2A11.A_D	18.1	0.98	96.48	26060	6100	308UJAQ3A100A_D
146	2.32	12.01	3244	2750	306UJAQ2A11.A_D	17.8	1.83	98.40	26579	6700	309UJAQ3A100A_D
135	2.78	12.95	3498	3000	307UJAQ2A12.A_D	17.2	2.58	101.75	27483	11200	310UJAQ3A100A_D
133	2.11	13.18	3560	2900	306UJAQ2A12.A_D	16.0	1.65	109.15	29482	6700	309UJAQ3A112A_D
118	2.52	14.85	4011	3100	307UJAQ2A14.A_D	15.5	2.32	112.87	30487	11200	310UJAQ3A112A_D
115	1.83	15.23	4114	2900	306UJAQ2A14.A_D	14.0	1.44	125.03	33771	6700	309UJAQ3A125A_D
107	2.34	16.38	4424	3200	307UJAQ2A16.A_D	13.5	2.03	129.29	34922	11200	310UJAQ3A125A_D
104	1.65	16.83	4546	2950	306UJAQ2A16.A_D	11.9	1.23	146.82	39657	6700	309UJAQ3A140A_D
97.1	2.20	18.03	4870	3400	307UJAQ2A18.A_D	11.5	1.73	151.82	41008	11200	310UJAQ3A140A_D
93.7	1.49	18.68	5046	3000	306UJAQ2A18.A_D	11.1	1.15	157.12	42439	6700	309UJAQ3A160A_D
88.9	3.62	19.68	5316	4500	308UJAQ2A20.A_D	10.8	1.61	162.47	43884	11200	310UJAQ3A160A_D
87.5	1.39	20.01	5405	3000	306UJAQ2A20.A_D	10.0	2.82	174.39	47104	19077	312UJAQ5A180A_D
86.2	2.02	20.31	5486	3500	307UJAQ2A20.A_D	10.0	1.03	175.48	47398	6700	309UJAQ3A180A_D
77.7	1.89	22.52	6083	3500	307UJAQ2A22.A_D	9.64	1.44	181.46	49014	11200	310UJAQ3A180A_D
77.3	3.28	22.65	6118	4600	308UJAQ2A22.A_D	8.65	2.43	202.42	54675	19077	312UJAQ5A200A_D
74.8	1.19	23.40	6321	3000	306UJAQ2A22.A_D	8.45	1.27	207.03	55920	11200	310UJAQ3A200A_D
69.4	1.11	25.20	6807	3000	306UJAQ2A25.A_D	7.80	1.17	224.46	60628	11200	310UJAQ3A224A_D
68.5	2.56	25.55	6901	5100	308UJAQ2A25.A_D	7.72	2.17	226.65	61220	19077	312UJAQ5A224A_D
67.8	1.71	25.80	6969	3700	307UJAQ2A25.A_D	6.75	1.01	259.09	69982	11200	310UJAQ3A250A_D
61.1	0.97	28.62	7730	3000	306UJAQ2A28.A_D	6.74	1.89	259.50	70093	19077	312UJAQ5A250A_D
60.2	2.53	29.09	7857	5100	308UJAQ2A28.A_D	6.15	1.73	284.71	76902	19077	312UJAQ5A280A_D
57.8	1.51	30.30	8184	3800	307UJAQ2A28.A_D	5.32	1.49	328.84	88822	19077	312UJAQ5A315A_D
54.8	2.59	31.91	8619	5100	308UJAQ2A31.A_D	4.81	1.35	363.52	98189	19077	312UJAQ5A355A_D
54.0	1.47	32.42	8757	3900	307UJAQ2A31.A_D	4.34	1.22	403.53	108996	19077	312UJAQ5A400A_D
51.9	2.14	33.69	9100	6100	308UJAQ3A35.A_D	4.05	1.14	432.19	116738	19077	312UJAQ5A450A_D
48.3	1.37	36.21	9781	4000	307UJAQ2A35.A_D	3.46	0.97	505.37	136504	19077	312UJAQ5A500A_D
47.8	2.37	36.58	9881	5300	308UJAQ2A35.A_D						
46.3	1.99	37.78	10205	6100	308UJAQ3A40.A_D						
44.1	2.27	39.65	10710	5400	308UJAQ2A40.A_D						
42.4	1.25	41.31	11158	4000	307UJAQ2A40.A_D						
40.9	3.56	42.75	11547	6700	309UJAQ3A45.A_D						
40.2	1.81	43.49	11747	6100	308UJAQ3A45.A_D						
39.1	1.19	44.79	12098	4000	307UJAQ2A45.A_D						
38.3	1.05	45.75	12357	4000	307UJAQ3A45.A_D						
37.4	2.01	46.78	12636	5700	308UJAQ2A45.A_D						
36.8	3.34	47.54	12841	6700	309UJAQ2A50.A_D						
33.8	1.08	51.70	13965	4000	307UJAQ2A50.A_D						
33.5	1.82	52.18	14094	5800	308UJAQ2A50.A_D						
31.3	2.84	56.00	15126	6700	309UJAQ2A56.A_D						
30.8	0.98	56.78	15337	4000	307UJAQ2A56.A_D						

Motors are available from Rexnord or Rexnord distributors.

7.5 HP/213TC Motor
Falk Part No. 10606594

Conforms to the following specifications:

C-Face motor less base, EPACT, Premium Efficient, rolled steel, TEFC, 1750 rpm, 208–230/460 Volts, 3 Phase, 60 Hz, NEMA B, 1.15 Service Factor.

Motors meeting other specifications are available upon request.

300UJ — Gearmotor Selection Table

10 HP/1750 RPM/215TC Frame Motor

Approx Output RPM	Service Factor	Exact Ratio	Actual Output Torque (lb-in)	Overhung Load (lb)	Drive Designation	Approx Output RPM	Service Factor	Exact Ratio	Actual Output Torque (lb-in)	Overhung Load (lb)	Drive Designation
589	2.35	2.97	1070	2000	306UJAQ2A3.1A_D	45.9	2.84	38.12	13729	6700	309UJAQ3A40.A_D
538	3.49	3.25	1170	2300	307UJAQ2A3.1A_D	44.1	1.70	39.65	14280	5400	308UJAQ2A40.A_D
507	2.34	3.45	1242	2050	306UJAQ2A3.5A_D	40.9	2.67	42.75	15396	6700	309UJAQ3A45.A_D
481	3.44	3.64	1311	2350	307UJAQ2A3.5A_D	40.2	2.91	43.51	15670	6700	309UJAQ2A45.A_D
453	2.35	3.86	1390	2050	306UJAQ2A4.0A_D	37.4	1.51	46.78	16847	5700	308UJAQ2A45.A_D
418	3.34	4.19	1509	2350	307UJAQ2A4.0A_D	36.8	2.51	47.54	17121	6700	309UJAQ2A50.A_D
396	2.31	4.42	1592	2100	306UJAQ2A4.5A_D	34.4	3.67	50.88	18324	10500	310UJAQ3A50.A_D
368	3.16	4.75	1711	2450	307UJAQ2A4.5A_D	33.5	1.37	52.18	18792	5800	308UJAQ2A50.A_D
361	2.10	4.85	1747	2200	306UJAQ2A5.0A_D	31.5	3.54	55.55	20006	10000	310UJAQ2A56.A_D
327	2.99	5.35	1927	2450	307UJAQ2A5.0A_D	31.3	2.13	56.00	20168	6700	309UJAQ2A56.A_D
313	1.82	5.60	2017	2300	306UJAQ2A5.6A_D	30.2	1.14	58.03	20899	6000	308UJAQ2A56.A_D
285	2.77	6.13	2208	2550	307UJAQ2A5.6A_D	28.4	1.93	61.68	22214	6700	309UJAQ2A63.A_D
283	1.65	6.19	2229	2400	306UJAQ2A6.3A_D	27.5	1.04	63.59	22901	6100	308UJAQ3A63.A_D
258	2.65	6.77	2438	2650	307UJAQ2A6.3A_D	27.0	3.03	64.88	23366	11000	310UJAQ3A63.A_D
255	1.48	6.87	2474	2400	306UJAQ2A7.1A_D	25.6	1.61	68.49	24666	6700	309UJAQ2A71.A_D
235	2.51	7.44	2679	2750	307UJAQ2A7.1A_D	24.9	0.98	70.17	25271	6100	308UJAQ3A71.A_D
222	2.81	7.87	2834	2750	307UJAQ2A8.0A_D	24.3	1.88	71.94	25909	6700	309UJAQ3A71.A_D
217	2.25	8.07	2906	2500	306UJAQ2A8.0A_D	23.5	2.64	74.39	26791	11200	310UJAQ3A71.A_D
198	2.65	8.82	3176	2800	307UJAQ2A9.0A_D	22.0	1.70	79.38	28588	6700	309UJAQ3A80.A_D
187	2.10	9.37	3375	2500	306UJAQ2A9.0A_D	21.3	2.39	82.09	29564	11200	310UJAQ3A80.A_D
172	2.42	10.15	3655	2800	307UJAQ2A10.A_D	20.0	1.55	87.35	31458	6700	309UJAQ3A90.A_D
167	1.99	10.49	3778	2650	306UJAQ2A10.A_D	19.4	2.18	90.33	32532	11200	310UJAQ3A90.A_D
152	2.26	11.51	4145	2900	307UJAQ2A11.A_D	17.8	1.37	98.40	35438	6700	309UJAQ3A100A_D
146	1.74	12.01	4325	2750	306UJAQ2A11.A_D	17.3	3.65	101.01	36378	17535	312UJAQ3A100A_D
135	2.09	12.95	4664	3000	307UJAQ2A12.A_D	17.2	1.93	101.75	36645	11200	310UJAQ3A100A_D
135	3.63	13.00	4682	3900	308UJAQ2A12.A_D	16.0	1.24	109.15	39310	6700	309UJAQ3A112A_D
133	1.58	13.18	4747	2900	306UJAQ2A12.A_D	15.7	3.31	111.49	40152	18691	312UJAQ3A112A_D
121	3.37	14.45	5204	4000	308UJAQ2A14.A_D	15.5	1.74	112.87	40649	11200	310UJAQ3A112A_D
118	1.89	14.85	5348	3100	307UJAQ2A14.A_D	14.1	2.97	124.07	44683	19077	312UJAQ3A125A_D
115	1.37	15.23	5485	2900	306UJAQ2A14.A_D	14.0	1.08	125.03	45029	6700	309UJAQ3A125A_D
107	1.76	16.38	5899	3200	307UJAQ2A16.A_D	13.5	1.52	129.29	46563	11200	310UJAQ3A125A_D
106	3.06	16.45	5924	4200	308UJAQ2A16.A_D	11.5	1.29	151.82	54677	11200	310UJAQ3A140A_D
104	1.24	16.83	6061	2950	306UJAQ2A16.A_D	10.8	1.21	162.47	58512	11200	310UJAQ3A160A_D
98.6	2.92	17.75	6393	4400	308UJAQ2A18.A_D	10.0	2.11	174.39	62805	19077	312UJAQ5A180A_D
97.1	1.65	18.03	6493	3400	307UJAQ2A18.A_D	9.64	1.08	181.46	65352	11200	310UJAQ3A180A_D
93.7	1.12	18.68	6727	3000	306UJAQ2A18.A_D	8.65	1.82	202.42	72900	19077	312UJAQ5A200A_D
88.9	2.72	19.68	7088	4500	308UJAQ2A20.A_D	7.72	1.63	226.65	81626	19077	312UJAQ5A224A_D
87.5	1.04	20.01	7206	3000	306UJAQ2A20.A_D	6.74	1.42	259.50	93457	19077	312UJAQ5A250A_D
86.2	1.51	20.31	7315	3500	307UJAQ2A20.A_D	6.15	1.29	284.71	102536	19077	312UJAQ5A280A_D
77.7	1.42	22.52	8110	3500	307UJAQ2A22.A_D	5.32	1.12	328.84	118429	19077	312UJAQ5A315A_D
77.3	2.46	22.65	8157	4600	308UJAQ2A22.A_D	4.81	1.01	363.52	130919	19077	312UJAQ5A355A_D
68.5	1.92	25.55	9202	5100	308UJAQ2A25.A_D						
67.8	1.29	25.80	9292	3700	307UJAQ2A25.A_D						
60.2	1.90	29.09	10477	5100	308UJAQ2A28.A_D						
57.8	1.14	30.30	10912	3800	307UJAQ2A28.A_D						
54.8	1.94	31.91	11492	5100	308UJAQ2A31.A_D						
54.0	1.10	32.42	11676	3900	307UJAQ2A31.A_D						
51.9	1.60	33.69	12133	6100	308UJAQ3A35.A_D						
50.3	3.42	34.82	12540	6400	309UJAQ2A35.A_D						
48.3	1.02	36.21	13041	4000	307UJAQ2A35.A_D						
47.8	1.78	36.58	13174	5300	308UJAQ2A35.A_D						
46.3	1.50	37.78	13606	6100	308UJAQ3A40.A_D						
46.0	3.23	38.01	13689	6600	309UJAQ2A40.A_D						

Motors are available from Rexnord or Rexnord distributors.

10 HP/215TC Motor
Falk Part No. 10606595

Conforms to the following specifications:

C-Face motor less base, EPACT, Premium Efficient, rolled steel, TEFC, 1750 rpm, 208–230/460 Volts, 3 Phase, 60 Hz, NEMA B, 1.00 Service Factor.

Motors meeting other specifications are available upon request.

300UJ — Gearmotor Selection Table

15 HP/1750 RPM/254TC Frame Motor

Approx Output RPM	Service Factor	Exact Ratio	Actual Output Torque (lb-in)	Overhung Load (lb)	Drive Designation	Approx Output RPM	Service Factor	Exact Ratio	Actual Output Torque (lb-in)	Overhung Load (lb)	Drive Designation
538	2.32	3.25	1756	2300	307UJAQ2A3.1A_E	35.1	2.63	49.92	26967	9400	310UJAQ2A50.A_E
481	2.30	3.64	1966	2350	307UJAQ2A3.5A_E	31.5	2.36	55.55	30009	10000	310UJAQ2A56.A_E
418	2.23	4.19	2263	2350	307UJAQ2A4.0A_E	31.3	1.42	56.00	30252	6700	309UJAQ2A56.A_E
368	2.10	4.75	2566	2450	307UJAQ2A4.5A_E	28.4	1.29	61.68	33320	6700	309UJAQ2A63.A_E
327	1.99	5.35	2890	2450	307UJAQ2A5.0A_E	27.0	2.02	64.88	35049	11000	310UJAQ3A63.A_E
305	3.57	5.74	3101	3100	308UJAQ2A5.6A_E	25.6	1.08	68.49	36999	6700	309UJAQ2A71.A_E
285	1.84	6.13	3312	2550	307UJAQ2A5.6A_E	24.2	3.40	72.20	39003	14523	312UJAQ3A71.A_E
258	1.77	6.77	3657	2650	307UJAQ2A6.3A_E	23.5	1.76	74.39	40187	11200	310UJAQ3A71.A_E
246	3.46	7.10	3836	3400	308UJAQ2A7.1A_E	22.2	3.11	78.91	42628	15601	312UJAQ3A80.A_E
235	1.67	7.44	4019	2750	307UJAQ2A7.1A_E	22.0	1.14	79.38	42882	6700	309UJAQ3A80.A_E
222	1.87	7.87	4251	2750	307UJAQ2A8.0A_E	21.3	1.60	82.09	44346	11200	310UJAQ3A80.A_E
214	3.23	8.17	4414	3400	308UJAQ2A8.0A_E	20.5	2.87	85.57	46226	16764	312UJAQ3A90.A_E
198	1.76	8.82	4765	2800	307UJAQ2A9.0A_E	20.0	1.03	87.35	47188	6700	309UJAQ3A90.A_E
190	3.02	9.23	4986	3600	308UJAQ2A9.0A_E	19.4	1.45	90.33	48798	11200	310UJAQ3A90.A_E
172	1.61	10.15	5483	2800	307UJAQ2A10.A_E	17.3	2.43	101.01	54567	17535	312UJAQ3A100.A_E
172	2.89	10.19	5505	3600	308UJAQ2A10.A_E	17.2	1.29	101.75	54967	11200	310UJAQ3A100.A_E
152	1.51	11.51	6218	2900	307UJAQ2A11.A_E	15.7	2.20	111.49	60228	18691	312UJAQ3A112.A_E
151	2.64	11.56	6245	3700	308UJAQ2A11.A_E	15.5	1.16	112.87	60974	11200	310UJAQ3A112.A_E
135	1.39	12.95	6996	3000	307UJAQ2A12.A_E	14.1	1.98	124.07	67024	19077	312UJAQ3A125.A_E
135	2.42	13.00	7023	3900	308UJAQ2A12.A_E	13.5	1.01	129.29	69844	11200	310UJAQ3A125.A_E
121	2.24	14.45	7806	4000	308UJAQ2A14.A_E	10.0	1.41	174.39	94208	19077	312UJAQ5A180.A_E
118	1.26	14.85	8022	3100	307UJAQ2A14.A_E	8.65	1.21	202.42	109350	19077	312UJAQ5A200.A_E
107	1.17	16.38	8849	3200	307UJAQ2A16.A_E	7.72	1.08	226.65	122440	19077	312UJAQ5A224.A_E
106	2.04	16.45	8887	4200	308UJAQ2A16.A_E	6.74	0.95	259.50	140186	19077	312UJAQ5A250.A_E
100	3.67	16.06	8676	5100	309UJAQ2A16.A_E						
98.6	1.95	17.75	9589	4400	308UJAQ2A18.A_E						
97.1	1.17	16.38	8849	3200	307UJAQ2A16.A_E						
88.9	1.81	19.68	10631	4500	308UJAQ2A20.A_E						
87.2	3.22	20.08	10848	5400	309UJAQ2A20.A_E						
86.2	1.01	20.31	10972	3500	307UJAQ2A20.A_E						
77.7	0.95	22.52	12166	3500	307UJAQ2A22.A_E						
77.3	1.64	22.65	12236	4600	308UJAQ2A22.A_E						
75.2	2.96	23.26	12565	5600	309UJAQ2A22.A_E						
68.5	1.28	25.55	13802	5100	308UJAQ2A25.A_E						
67.7	2.79	25.85	13965	5700	309UJAQ2A25.A_E						
63.4	2.67	27.61	14915	5900	309UJAQ2A28.A_E						
60.2	1.27	29.09	15715	5100	308UJAQ2A28.A_E						
57.0	2.48	30.69	16579	6100	309UJAQ2A31.A_E						
54.1	3.57	32.32	17460	8100	310UJAQ2A31.A_E						
50.3	2.28	34.82	18810	6400	309UJAQ2A35.A_E						
49.5	3.36	35.33	19086	8500	310UJAQ2A35.A_E						
47.8	1.19	36.58	19761	5300	308UJAQ2A35.A_E						
46.3	1.00	37.78	20409	6100	308UJAQ3A40.A_E						
46.0	2.16	38.01	20534	6600	309UJAQ2A40.A_E						
45.9	1.89	38.12	20593	6700	309UJAQ3A40.A_E						
45.7	3.16	38.31	20696	8800	310UJAQ2A40.A_E						
44.4	2.93	39.42	21295	9700	310UJAQ3A40.A_E						
44.1	1.14	39.65	21419	5400	308UJAQ2A40.A_E						
40.9	1.78	42.75	23094	6700	309UJAQ3A45.A_E						
40.2	1.94	43.51	23505	6700	309UJAQ2A45.A_E						
38.7	2.79	45.22	24428	9200	310UJAQ2A45.A_E						
37.4	1.01	46.78	25271	5700	308UJAQ2A45.A_E						
36.8	1.67	47.54	25682	6700	309UJAQ2A50.A_E						

Motors are available from Rexnord or Rexnord distributors.

15 HP/254TC Motor
Falk Part No. TBD

Conforms to the following specifications:

C-Face motor less base, EPACT, Premium Efficient, TEFC, 1750 rpm, 208–230/460 Volts, 3 Phase, 60 Hz, NEMA B, 1.15 Service Factor.

Motors meeting other specifications are available upon request.

300UJ — Gearmotor Selection Table

20 HP/1750 RPM/256TC Frame Motor

Approx Output RPM	Service Factor	Exact Ratio	Actual Output Torque (lb-in)	Overhung Load (lb)	Drive Designation	Approx Output RPM	Service Factor	Exact Ratio	Actual Output Torque (lb-in)	Overhung Load (lb)	Drive Designation
549	3.05	3.19	2298	2900	308UJAQ2A3.1A_E	44.4	2.20	39.42	28394	9700	310UJAQ3A40.A_E
538	1.74	3.25	2341	2300	307UJAQ2A3.1A_E	40.2	1.45	43.51	31340	6700	309UJAQ2A45.A_E
497	3.05	3.52	2535	2950	308UJAQ2A3.5A_E	38.7	2.09	45.22	32571	9200	310UJAQ2A45.A_E
481	1.72	3.64	2622	2350	307UJAQ2A3.5A_E	36.8	1.25	47.54	34242	6700	309UJAQ2A50.A_E
431	3.05	4.06	2924	2950	308UJAQ2A4.0A_E	35.1	1.97	49.92	35957	9400	310UJAQ2A50.A_E
418	1.67	4.19	3018	2350	307UJAQ2A4.0A_E	31.5	1.77	55.55	40012	10000	310UJAQ2A56.A_E
382	2.94	4.58	3299	3000	308UJAQ2A4.5A_E	31.5	3.31	55.62	40062	12674	312UJAQ3A56.A_E
368	1.58	4.75	3421	2450	307UJAQ2A4.5A_E	31.3	1.06	56.00	40336	6700	309UJAQ2A56.A_E
346	2.82	5.06	3645	3100	308UJAQ2A5.0A_E	28.4	0.97	61.68	44427	6700	309UJAQ2A63.A_E
327	1.49	5.35	3854	2450	307UJAQ2A5.0A_E	28.0	2.94	62.59	45083	13945	312UJAQ3A63.A_E
305	2.68	5.74	4134	3100	308UJAQ2A5.6A_E	27.0	1.52	64.88	46732	11000	310UJAQ3A63.A_E
285	1.38	6.13	4415	2550	307UJAQ2A5.6A_E	24.2	2.55	72.20	52005	14523	312UJAQ3A71.A_E
272	2.71	6.43	4631	3100	308UJAQ2A6.3A_E	23.5	1.32	74.39	53582	11200	310UJAQ3A71.A_E
258	1.32	6.77	4876	2650	307UJAQ2A6.3A_E	22.2	2.34	78.91	56838	15601	312UJAQ3A80.A_E
246	2.60	7.10	5114	3400	308UJAQ2A7.1A_E	21.3	1.20	82.09	59128	11200	310UJAQ3A80.A_E
235	1.26	7.44	5359	2750	307UJAQ2A7.1A_E	20.5	2.15	85.57	61635	16764	312UJAQ3A90.A_E
222	1.41	7.87	5669	2750	307UJAQ2A8.0A_E	19.4	1.09	90.33	65063	11200	310UJAQ3A90.A_E
214	2.42	8.17	5885	3400	308UJAQ2A8.0A_E	17.3	1.82	101.01	72756	17535	312UJAQ3A100.A_E
198	1.32	8.82	6353	2800	307UJAQ2A9.0A_E	17.2	0.97	101.75	73289	11200	310UJAQ3A100.A_E
190	2.26	9.23	6648	3600	308UJAQ2A9.0A_E	15.7	1.65	111.49	80305	18691	312UJAQ3A112.A_E
172	1.21	10.15	7311	2800	307UJAQ2A10.A_E	14.1	1.49	124.07	89366	19077	312UJAQ3A125.A_E
172	2.17	10.19	7340	3600	308UJAQ2A10.A_E	10.0	1.06	174.39	125611	19077	312UJAQ5A180.A_E
168	3.48	10.43	7513	4600	309UJAQ2A10.A_E	21.3	1.20	82.09	59128	11200	310UJAQ3A80.A_E
152	1.13	11.51	8290	2900	307UJAQ2A11.A_E	20.5	2.15	85.57	61635	16764	312UJAQ3A90.A_E
151	1.98	11.56	8327	3700	308UJAQ2A11.A_E	19.4	1.09	90.33	65063	11200	310UJAQ3A90.A_E
150	3.27	11.66	8399	4700	309UJAQ2A11.A_E	17.3	1.82	101.01	72756	17535	312UJAQ3A100.A_E
139	3.17	12.59	9068	4900	309UJAQ2A12.A_E	17.2	0.97	101.75	73289	11200	310UJAQ3A100.A_E
135	1.04	12.95	9328	3000	307UJAQ2A12.A_E	15.7	1.65	111.49	80305	18691	312UJAQ3A112.A_E
135	1.81	13.00	9364	3900	308UJAQ2A12.A_E	14.1	1.49	124.07	89366	19077	312UJAQ3A125.A_E
123	2.95	14.18	10214	5000	309UJAQ2A14.A_E	10.0	1.06	174.39	125611	19077	312UJAQ5A180.A_E
121	1.68	14.45	10408	4000	308UJAQ2A14.A_E						
109	2.75	16.06	11568	5100	309UJAQ2A16.A_E						
106	1.53	16.45	11849	4200	308UJAQ2A16.A_E						
100	2.63	17.51	12612	5300	309UJAQ2A18.A_E						
98.6	1.46	17.75	12785	4400	308UJAQ2A18.A_E						
88.9	1.36	19.68	14175	4500	308UJAQ2A20.A_E						
87.2	2.42	20.08	14463	5400	309UJAQ2A20.A_E						
79.3	3.51	22.06	15890	7400	310UJAQ2A22.A_E						
77.3	1.23	22.65	16314	4600	308UJAQ2A22.A_E						
75.2	2.22	23.26	16754	5600	309UJAQ2A22.A_E						
70.3	3.23	24.90	17935	7600	310UJAQ2A25.A_E						
68.5	0.96	25.55	18403	5100	308UJAQ2A25.A_E						
67.7	2.09	25.85	18619	5700	309UJAQ2A25.A_E						
63.4	2.00	27.61	19887	5900	309UJAQ2A28.A_E						
62.5	2.98	28.02	20182	7900	310UJAQ2A28.A_E						
60.2	0.95	29.09	20953	5100	308UJAQ2A28.A_E						
57.0	1.86	30.69	22106	6100	309UJAQ2A31.A_E						
54.8	0.97	31.91	22984	5100	308UJAQ2A31.A_E						
54.1	2.68	32.32	23280	8100	310UJAQ2A31.A_E						
50.3	1.71	34.82	25080	6400	309UJAQ2A35.A_E						
49.5	2.52	35.33	25448	8500	310UJAQ2A35.A_E						
46.0	1.62	38.01	27378	6600	309UJAQ2A40.A_E						
45.7	2.37	38.31	27594	8800	310UJAQ2A40.A_E						

Motors are available from Rexnord or Rexnord distributors.

20 HP/256TC Motor
Falk Part No. TBD

Conforms to the following specifications:

C-Face motor less base, EPACT, Premium Efficient, TEFC, 1750 rpm, 208–230/460 Volts, 3 Phase, 60 Hz, NEMA B, 1.15 Service Factor.

Motors meeting other specifications are available upon request.

300UJ — Gearmotor Selection Table

25 HP/1750 RPM/284TC Frame Motor

Approx Output RPM	Service Factor	Exact Ratio	Actual Output Torque (lb-in)	Overhung Load (lb)	Drive Designation
342	3.41	5.19	4673	4300	309UJAQ2A5.0A_F
305	3.21	5.81	5231	4300	309UJAQ2A5.6A_F
276	3.48	6.35	5717	4300	309UJAQ2A6.3A_F
248	3.35	7.05	6348	4400	309UJAQ2A7.1A_F
208	3.10	8.40	7563	4400	309UJAQ2A8.0A_F
194	3.00	9.02	8121	4600	309UJAQ2A9.0A_F
168	2.78	10.43	9391	4600	309UJAQ2A10.A_F
150	2.61	11.66	10498	4700	309UJAQ2A11.A_F
139	2.54	12.59	11335	4900	309UJAQ2A12.A_F
123	2.36	14.18	12767	5000	309UJAQ2A14.A_F
111	3.59	15.73	14163	6700	310UJAQ2A16.A_F
109	2.20	16.06	14460	5100	309UJAQ2A16.A_F
100	2.11	17.51	15765	5300	309UJAQ2A18.A_F
99.0	3.28	17.68	15918	7000	310UJAQ2A18.A_F
88.9	3.05	19.69	17728	7200	310UJAQ2A20.A_F
87.2	1.93	20.08	18079	5400	309UJAQ2A20.A_F
79.3	2.81	22.06	19862	7400	310UJAQ2A22.A_F
75.2	1.77	23.26	20942	5600	309UJAQ2A22.A_F
70.3	2.59	24.90	22419	7600	310UJAQ2A25.A_F
67.7	1.67	25.85	23274	5700	309UJAQ2A25.A_F
63.4	1.60	27.61	24859	5900	309UJAQ2A28.A_F
62.5	2.39	28.02	25228	7900	310UJAQ2A28.A_F
57.0	1.49	30.69	27632	6100	309UJAQ2A31.A_F
54.1	2.14	32.32	29100	8100	310UJAQ2A31.A_F
50.3	1.37	34.82	31350	6400	309UJAQ2A35.A_F
49.5	2.02	35.33	31810	8500	310UJAQ2A35.A_F
46.0	1.29	38.01	34223	6600	309UJAQ2A40.A_F
45.9	1.13	38.12	34322	6700	309UJAQ3A40.A_F
45.7	1.90	38.31	34493	8800	310UJAQ2A40.A_F
40.2	1.16	43.51	39175	6700	309UJAQ2A45.A_F
39.8	3.35	43.97	39589	12332	312UJAQ3A45.A_F
38.7	1.67	45.22	40714	9200	310UJAQ2A45.A_F
36.8	1.00	47.54	42803	6700	309UJAQ2A50.A_F
35.5	2.99	49.26	44352	11803	312UJAQ3A50.A_F
35.1	1.58	49.92	44946	9400	310UJAQ2A50.A_F
31.5	1.42	55.55	50015	10000	310UJAQ2A56.A_F
31.5	2.65	55.62	50078	12674	312UJAQ3A56.A_F
28.0	2.36	62.59	56353	13945	312UJAQ3A63.A_F
27.0	1.21	64.88	58415	11000	310UJAQ3A63.A_F
24.2	2.04	72.20	65006	14523	312UJAQ3A71.A_F
23.5	1.06	74.39	66978	11200	310UJAQ3A71.A_F
22.2	1.87	78.91	71047	15601	312UJAQ3A80.A_F
21.3	0.96	82.09	73910	11200	310UJAQ3A80.A_F
20.5	1.72	85.57	77044	16764	312UJAQ3A90.A_F
17.3	1.46	101.01	90945	17535	312UJAQ3A100A_F
15.7	1.32	111.49	100381	18691	312UJAQ3A112A_F
14.1	1.19	124.07	111707	19077	312UJAQ3A125A_F
28.0	2.36	62.59	56353	13945	312UJAQ3A63.A_F
27.0	1.21	64.88	58415	11000	310UJAQ3A63.A_F
24.2	2.04	72.20	65006	14523	312UJAQ3A71.A_F
23.5	1.06	74.39	66978	11200	310UJAQ3A71.A_F
22.2	1.87	78.91	71047	15601	312UJAQ3A80.A_F
21.3	0.96	82.09	73910	11200	310UJAQ3A80.A_F

Approx Output RPM	Service Factor	Exact Ratio	Actual Output Torque (lb-in)	Overhung Load (lb)	Drive Designation
20.5	1.72	85.57	77044	16764	312UJAQ3A90.A_F
17.3	1.46	101.01	90945	17535	312UJAQ3A100A_F
15.7	1.32	111.49	100381	18691	312UJAQ3A112A_F
14.1	1.19	124.07	111707	19077	312UJAQ3A125A_F

Motors are available from Rexnord or Rexnord distributors.

25 HP/284TC Motor
Falk Part No. TBD

Conforms to the following specifications:

C-Face motor less base, EPACT, Premium Efficient, TEFC, 1750 rpm, 208–230/460 Volts, 3 Phase, 60 Hz, NEMA B, 1.15 Service Factor.

Motors meeting other specifications are available upon request.

300UJ — Gearmotor Selection Table

30 HP/1750 RPM/286TC Frame Motor

Approx Output RPM	Service Factor	Exact Ratio	Actual Output Torque (lb-in)	Overhung Load (lb)	Drive Designation
561	2.85	3.16	3414	4000	309UJAQ2A3.1A_F
506	2.82	3.51	3792	4300	309UJAQ2A3.5A_F
424	2.84	4.18	4516	4200	309UJAQ2A4.0A_F
395	2.83	4.49	4851	4300	309UJAQ2A4.5A_F
342	2.84	5.19	5607	4300	309UJAQ2A5.0A_F
305	2.68	5.81	6277	4300	309UJAQ2A5.6A_F
276	2.90	6.35	6861	4300	309UJAQ2A6.3A_F
248	2.79	7.05	7617	4400	309UJAQ2A7.1A_F
208	2.58	8.40	9076	4400	309UJAQ2A8.0A_F
194	2.50	9.02	9745	4600	309UJAQ2A9.0A_F
168	2.32	10.43	11269	4600	309UJAQ2A10.A_F
150	2.18	11.66	12598	4700	309UJAQ2A11.A_F
141	3.54	12.38	13376	6300	310UJAQ2A12.A_F
139	2.11	12.59	13603	4900	309UJAQ2A12.A_F
123	1.96	14.18	15320	5000	309UJAQ2A14.A_F
123	3.19	14.26	15407	6500	310UJAQ2A14.A_F
111	2.99	15.73	16995	6700	310UJAQ2A16.A_F
109	1.84	16.06	17352	5100	309UJAQ2A16.A_F
100	1.75	17.51	18918	5300	309UJAQ2A18.A_F
99.0	2.73	17.68	19102	7000	310UJAQ2A18.A_F
88.9	2.54	19.69	21274	7200	310UJAQ2A20.A_F
87.2	1.61	20.08	21695	5400	309UJAQ2A20.A_F
79.3	2.34	22.06	23834	7400	310UJAQ2A22.A_F
75.2	1.48	23.26	25131	5600	309UJAQ2A22.A_F
70.3	2.15	24.90	26903	7600	310UJAQ2A25.A_F
67.7	1.39	25.85	27929	5700	309UJAQ2A25.A_F
63.4	1.34	27.61	29831	5900	309UJAQ2A28.A_F
62.5	1.99	28.02	30274	7900	310UJAQ2A28.A_F
57.0	1.24	30.69	33158	6100	309UJAQ2A31.A_F
54.1	1.79	32.32	34919	8100	310UJAQ2A31.A_F
50.3	1.14	34.82	37621	6400	309UJAQ2A35.A_F
49.8	3.50	35.14	37966	10984	312UJAQ3A35.A_F
49.5	1.68	35.33	38172	8500	310UJAQ2A35.A_F
46.0	1.08	38.01	41067	6600	309UJAQ2A40.A_F
45.9	0.95	38.12	41186	6700	309UJAQ3A40.A_F
45.7	1.58	38.31	41391	8800	310UJAQ2A40.A_F
44.3	3.11	39.49	42666	11754	312UJAQ3A40.A_F
40.2	0.97	43.51	47009	6700	309UJAQ2A45.A_F
39.8	2.79	43.97	47506	12332	312UJAQ3A45.A_F
38.7	1.39	45.22	48857	9200	310UJAQ2A45.A_F
35.5	2.49	49.26	53222	11803	312UJAQ3A50.A_F
35.1	1.31	49.92	53935	9400	310UJAQ2A50.A_F
31.5	1.18	55.55	60018	10000	310UJAQ2A56.A_F
31.5	2.21	55.62	60093	12674	312UJAQ3A56.A_F
27.0	1.01	64.88	70098	11000	310UJAQ3A63.A_F
24.2	1.70	72.20	78007	14523	312UJAQ3A71.A_F
22.2	1.56	78.91	85257	15601	312UJAQ3A80.A_F
20.5	1.44	85.57	92452	16764	312UJAQ3A90.A_F
17.3	1.22	101.01	109134	17535	312UJAQ3A100A_F
14.1	0.99	124.07	134049	19077	312UJAQ3A125A_F
24.2	1.70	72.20	78007	14523	312UJAQ3A71.A_F
22.2	1.56	78.91	85257	15601	312UJAQ3A80.A_F
20.5	1.44	85.57	92452	16764	312UJAQ3A90.A_F

Approx Output RPM	Service Factor	Exact Ratio	Actual Output Torque (lb-in)	Overhung Load (lb)	Drive Designation
17.3	1.22	101.01	109134	17535	312UJAQ3A100A_F
14.1	0.99	124.07	134049	19077	312UJAQ3A125A_F

Motors are available from Rexnord or Rexnord distributors.

30 HP/286TC Motor
Falk Part No. TBD

Conforms to the following specifications:

C-Face motor less base, EPACT, Premium Efficient, TEFC, 1750 rpm, 208–230/460 Volts, 3 Phase, 60 Hz, NEMA B, 1.15 Service Factor.

Motors meeting other specifications are available upon request.

300UJ — Gearmotor Selection Table

40 HP/1750 RPM/324TC Frame Motor

Approx Output RPM	Service Factor	Exact Ratio	Actual Output Torque (lb-in)	Overhung Load (lb)	Drive Designation
561	2.14	3.16	4552	4000	309UJAQ2A3.1A_G
506	2.12	3.51	5056	4300	309UJAQ2A3.5A_G
439	2.93	3.99	5748	5800	310UJAQ2A4.0A_G
424	2.13	4.18	6022	4200	309UJAQ2A4.0A_G
395	2.12	4.49	6468	4300	309UJAQ2A4.5A_G
387	2.94	4.52	6511	5800	310UJAQ2A4.5A_G
355	2.93	4.93	7102	5800	310UJAQ2A5.0A_G
342	2.13	5.19	7477	4300	309UJAQ2A5.0A_G
311	2.84	5.62	8096	6000	310UJAQ2A5.6A_G
305	2.01	5.81	8370	4300	309UJAQ2A5.6A_G
276	2.18	6.35	9148	4300	309UJAQ2A6.3A_G
248	2.09	7.05	10156	4400	309UJAQ2A7.1A_G
247	3.64	7.08	10199	5600	310UJAQ2A7.1A_G
231	3.52	7.57	10905	6730	312UJAQ3A8.0A_G
218	3.45	8.02	11553	5600	310UJAQ2A8.0A_G
208	1.94	8.40	12101	4400	309UJAQ2A8.0A_G
204	3.52	8.57	12346	7015	312UJAQ3A9.0A_G
194	1.87	9.02	12994	4600	309UJAQ2A9.0A_G
192	3.21	9.10	13109	5800	310UJAQ2A9.0A_G
180	3.52	9.70	13974	7015	312UJAQ3A10.A_G
177	3.10	9.91	14276	5900	310UJAQ2A10.A_G
168	1.74	10.43	15025	4600	309UJAQ2A10.A_G
159	3.52	11.01	15861	7308	312UJAQ3A11.A_G
155	2.80	11.31	16293	6200	310UJAQ2A11.A_G
150	1.63	11.66	16797	4700	309UJAQ2A11.A_G
146	3.52	12.00	17287	7308	312UJAQ3A12.A_G
141	2.65	12.38	17834	6300	310UJAQ2A12.A_G
139	1.59	12.59	18137	4900	309UJAQ2A12.A_G
123	1.47	14.18	20427	5000	309UJAQ2A14.A_G
123	2.39	14.26	20543	6500	310UJAQ2A14.A_G
111	2.25	15.73	22660	6700	310UJAQ2A16.A_G
109	1.38	16.06	23136	5100	309UJAQ2A16.A_G
100	1.32	17.51	25224	5300	309UJAQ2A18.A_G
99.0	2.05	17.68	25469	7000	310UJAQ2A18.A_G
88.9	1.90	19.69	28365	7200	310UJAQ2A20.A_G
87.2	1.21	20.08	28927	5400	309UJAQ2A20.A_G
79.3	1.75	22.06	31779	7400	310UJAQ2A22.A_G
75.2	1.11	23.26	33508	5600	309UJAQ2A22.A_G
70.3	1.62	24.90	35870	7600	310UJAQ2A25.A_G
69.3	3.65	25.26	36389	9635	312UJAQ3A25.A_G
67.7	1.05	25.85	37239	5700	309UJAQ2A25.A_G
63.4	1.00	27.61	39774	5900	309UJAQ2A28.A_G
63.3	3.33	27.66	39846	10213	312UJAQ3A28.A_G
62.5	1.49	28.02	40365	7900	310UJAQ2A28.A_G
54.9	2.89	31.85	45882	10791	312UJAQ3A31.A_G
54.1	1.34	32.32	46559	8100	310UJAQ2A31.A_G
49.8	2.62	35.14	50622	10984	312UJAQ3A35.A_G
49.5	1.26	35.33	50895	8500	310UJAQ2A35.A_G
45.7	1.19	38.31	55188	8800	310UJAQ2A40.A_G
44.3	2.33	39.49	56888	11754	312UJAQ3A40.A_G
39.8	2.10	43.97	63342	12332	312UJAQ3A45.A_G
38.7	1.05	45.22	65143	9200	310UJAQ2A45.A_G
35.5	1.87	49.26	70963	11803	312UJAQ3A50.A_G

Approx Output RPM	Service Factor	Exact Ratio	Actual Output Torque (lb-in)	Overhung Load (lb)	Drive Designation
35.1	0.98	49.92	71913	9400	310UJAQ2A50.A_G
31.5	1.66	55.62	80125	12674	312UJAQ3A56.A_G
28.0	1.47	62.59	90165	13945	312UJAQ3A63.A_G
24.2	1.28	72.20	104009	14523	312UJAQ3A71.A_G
22.2	1.17	78.91	113675	15601	312UJAQ3A80.A_G
20.5	1.08	85.57	123270	16764	312UJAQ3A90.A_G

Motors are available from Rexnord or Rexnord distributors.

40 HP/324TC Motor
Falk Part No. TBD

Conforms to the following specifications:

C-Face motor less base, EPACT, Premium Efficient, TEFC, 1750 rpm, 208–230/460 Volts, 3 Phase, 60 Hz, NEMA B, 1.15 Service Factor.

Motors meeting other specifications are available upon request.

300UJ — Gearmotor Selection Table

50 HP/1750 RPM/326TC Frame Motor

Approx Output RPM	Service Factor	Exact Ratio	Actual Output Torque (lb-in)	Overhung Load (lb)	Drive Designation
563	2.34	3.11	5600	5600	310UJAQ2A3.1A_G
561	1.71	3.16	5690	4000	309UJAQ2A3.1A_G
506	1.69	3.51	6321	4300	309UJAQ2A3.5A_G
497	2.35	3.52	6339	5700	310UJAQ2A3.5A_G
439	2.34	3.99	7185	5800	310UJAQ2A4.0A_G
424	1.70	4.18	7527	4200	309UJAQ2A4.0A_G
395	1.70	4.49	8085	4300	309UJAQ2A4.5A_G
387	2.35	4.52	8139	5800	310UJAQ2A4.5A_G
355	2.34	4.93	8878	5800	310UJAQ2A5.0A_G
342	1.70	5.19	9346	4300	309UJAQ2A5.0A_G
311	2.27	5.62	10120	6000	310UJAQ2A5.6A_G
305	1.61	5.81	10462	4300	309UJAQ2A5.6A_G
280	3.07	6.25	11254	6000	310UJAQ2A6.3A_G
276	1.74	6.35	11435	4300	309UJAQ2A6.3A_G
248	1.67	7.05	12695	4400	309UJAQ2A7.1A_G
247	2.92	7.08	12749	5600	310UJAQ2A7.1A_G
231	2.82	7.57	13631	6730	312UJAQ3A8.0A_G
218	2.76	8.02	14442	5600	310UJAQ2A8.0A_G
208	1.55	8.40	15126	4400	309UJAQ2A8.0A_G
204	2.82	8.57	15432	7015	312UJAQ3A9.0A_G
194	1.50	9.02	16242	4600	309UJAQ2A9.0A_G
192	2.57	9.10	16387	5800	310UJAQ2A9.0A_G
180	2.82	9.70	17467	7015	312UJAQ3A10.A_G
177	2.48	9.91	17845	5900	310UJAQ2A10.A_G
168	1.39	10.43	18781	4600	309UJAQ2A10.A_G
159	2.82	11.01	19826	7308	312UJAQ3A11.A_G

Approx Output RPM	Service Factor	Exact Ratio	Actual Output Torque (lb-in)	Overhung Load (lb)	Drive Designation
155	2.24	11.31	20366	6200	310UJAQ2A11.A_G
150	1.31	11.66	20996	4700	309UJAQ2A11.A_G
146	2.82	12.00	21609	7308	312UJAQ3A12.A_G
141	2.12	12.38	22293	6300	310UJAQ2A12.A_G
139	1.27	12.59	22671	4900	309UJAQ2A12.A_G
123	1.18	14.18	25534	5000	309UJAQ2A14.A_G
123	1.91	14.26	25678	6500	310UJAQ2A14.A_G
111	1.80	15.73	28325	6700	310UJAQ2A16.A_G
109	1.10	16.06	28919	5100	309UJAQ2A16.A_G
99.0	1.64	17.68	31837	7000	310UJAQ2A18.A_G
97.7	3.59	17.91	32251	7879	312UJAQ3A18.A_G
86.1	3.34	20.32	36591	8264	312UJAQ3A20.A_G
79.0	3.20	22.14	39868	8364	312UJAQ3A22.A_G
70.3	1.29	24.90	44838	7600	310UJAQ2A25.A_G
69.3	2.92	25.26	45486	9635	312UJAQ3A25.A_G
63.3	2.67	27.66	49808	10213	312UJAQ3A28.A_G
62.5	1.19	28.02	50456	7900	310UJAQ2A28.A_G
54.9	2.31	31.85	57353	10791	312UJAQ3A31.A_G
54.1	1.07	32.32	58199	8100	310UJAQ2A31.A_G
49.8	2.10	35.14	63277	10984	312UJAQ3A35.A_G
49.5	1.01	35.33	63619	8500	310UJAQ2A35.A_G
45.7	0.95	38.31	68985	8800	310UJAQ2A40.A_G
44.3	1.87	39.49	71110	11754	312UJAQ3A40.A_G
31.5	1.33	55.62	100156	12674	312UJAQ3A56.A_G
28.0	1.18	62.59	112707	13945	312UJAQ3A63.A_G
24.2	1.02	72.20	130012	14523	312UJAQ3A71.A_G

Motors are available from Rexnord or Rexnord distributors.

50 HP/326TC Motor
Falk Part No. TBD

Conforms to the following specifications:

C-Face motor less base, EPACT, Premium Efficient, TEFC, 1750 rpm, 208–230/460 Volts, 3 Phase, 60 Hz, NEMA B, 1.15 Service Factor.

Motors meeting other specifications are available upon request.

300UJ — Double & Triple Reduction Gearmotor/Straight Hollow

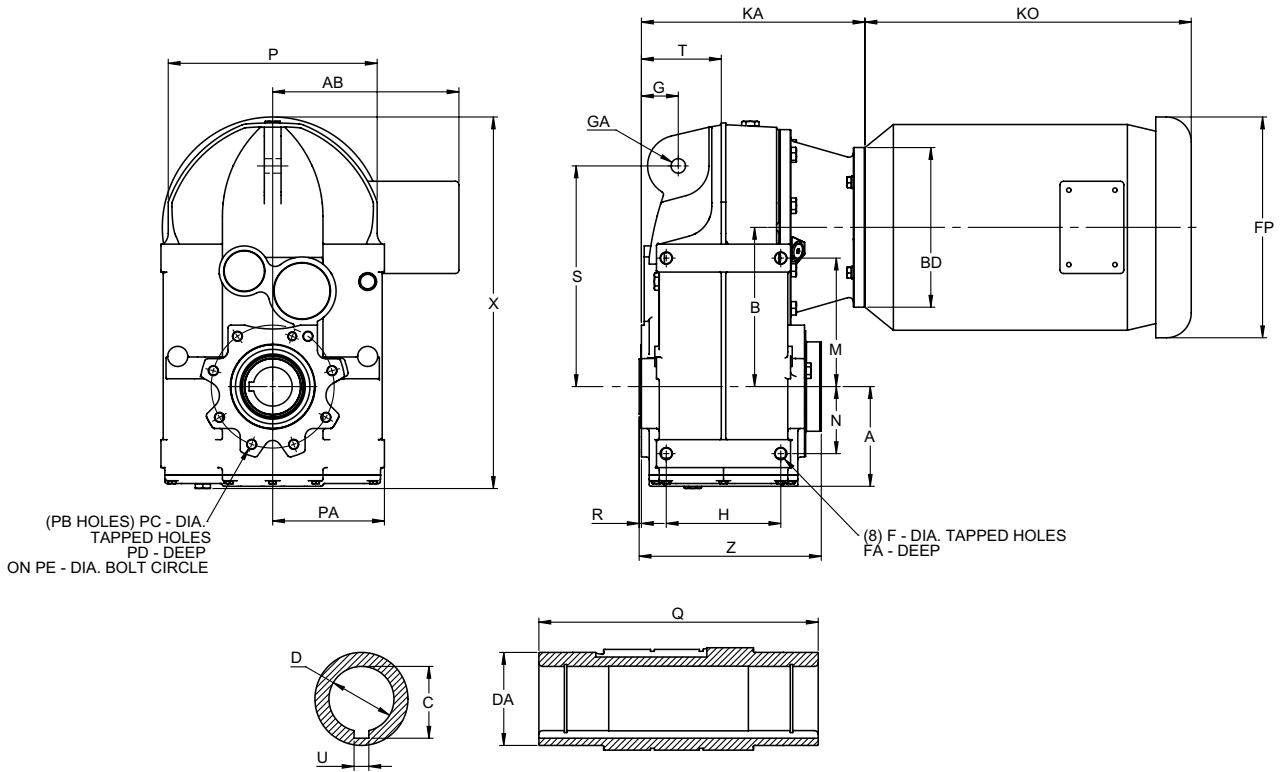

Type UJ Gearmotor — Straight Hollow — 300UJAJ (Dimensions—Inch)

Size	A	B	C	D	DA	F	FA	G	GA	H	M	N	P	PA	PB	PC	PD	PE	Q	R	S	T	U	X	Z
302	3.07	4.53	1.12	1.000 +0.0008, -0	1.77	M8	0.51	1.20	0.55	3.03	3.31	1.22	5.51	3.24	5.00	M8	0.51	3.70	4.72	0.08	6.22	2.24	0.25	10.47	5.17
302	3.07	4.53	1.37	1.250 +0.0010, -0	1.77	M8	0.51	1.20	0.55	3.03	3.31	1.22	5.51	3.24	5.00	M8	0.51	3.70	4.72	0.08	6.22	2.24	0.25	10.47	5.17
304	3.39	4.82	1.37	1.250 +0.0010, -0	1.97	M10	0.83	1.18	0.55	3.66	4.02	1.69	5.51	3.54	7.00	M8	0.51	4.72	5.91	0.08	6.69	2.89	0.25	11.16	6.35
304	3.39	4.82	1.52	1.375 +0.0010, -0	1.97	M10	0.83	1.18	0.55	3.66	4.02	1.69	5.51	3.54	7.00	M8	0.51	4.72	5.91	0.08	6.69	2.89	0.31	11.16	6.35
306	4.11	6.84	1.67	1.500 +0.0010, -0	2.17	M12	0.71	1.54	0.55	4.41	5.19	2.36	7.40	4.17	6.00	M12	0.71	4.92	7.09	0.08	8.58	3.52	0.38	14.82	7.62
307	4.89	8.61	2.23	2.000 +0.0012, -0	2.76	M16	1.02	1.87	0.87	5.51	6.69	2.76	10.63	5.31	8.00	M12	0.87	5.59	8.27	0.10	10.94	3.98	0.50	18.90	8.78
308	5.93	9.47	2.66	2.375 +0.0012, -0	3.35	M16	1.02	2.34	0.87	6.50	8.27	3.94	11.38	6.50	6.00	M16	1.02	7.01	9.45	0.10	13.62	4.70	0.63	21.11	10.06
309	7.03	11.22	3.04	2.750 +0.0012, -0	3.94	M20	1.10	2.60	1.02	8.07	9.06	4.72	14.72	7.87	8.00	M16	1.22	8.66	11.81	0.16	15.55	5.63	0.63	25.89	12.83
310	7.70	13.27	3.59	3.250 +0.0014, -0	4.72	M24	1.42	2.83	1.02	8.66	10.83	4.92	15.98	8.86	8.00	M20	1.18	10.24	13.78	0.63	19.09	6.28	0.75	29.51	14.33
312	8.66	14.57	4.45	4.000 +0.0014, -0	5.51	M30	1.77	3.74	1.30	10.63	15.67	5.59	17.64	10.43	11.00	M20	1.10	11.81	16.14	0.59	3.74	7.60	1.00	34.11	16.73

NEMA C-FACE INPUT — Double & Triple Reduction (Dimensions—Inch)

Frame Size	Drive Size											
	All Sizes				KA							
	AB	BD	FP	K0	302	304	306	307	308	309	310	312
56C	5.25	6.50	7.19	9.32	7.80	8.60	9.04	10.30	11.14	-	-	-
142TC/145TC	5.25	6.50	7.19	12.07	7.80	8.60	9.04	10.30	11.14	-	-	-
182TC/184TC	5.88	9.00	8.50	15.43	8.70	9.51	10.83	12.09	12.93	-	-	-
213TC/215TC	7.38	9.00	10.19	16.31	-	-	10.83	12.09	12.93	14.13	15.35	19.21
254TC/256TC	9.63	10.00	12.50	19.88	-	-	-	13.56	14.41	15.61	16.83	20.69
284TC/286TC	13.13	11.25	15.56	23.18	-	-	-	-	-	15.75	16.97	20.83
324TC/326TC	14.13	13.38	16.94	25.25	-	-	-	-	-	17.36	18.58	22.44

300UJ — Quadruple & Quintuple Reduction Gearmotor/Straight Hollow

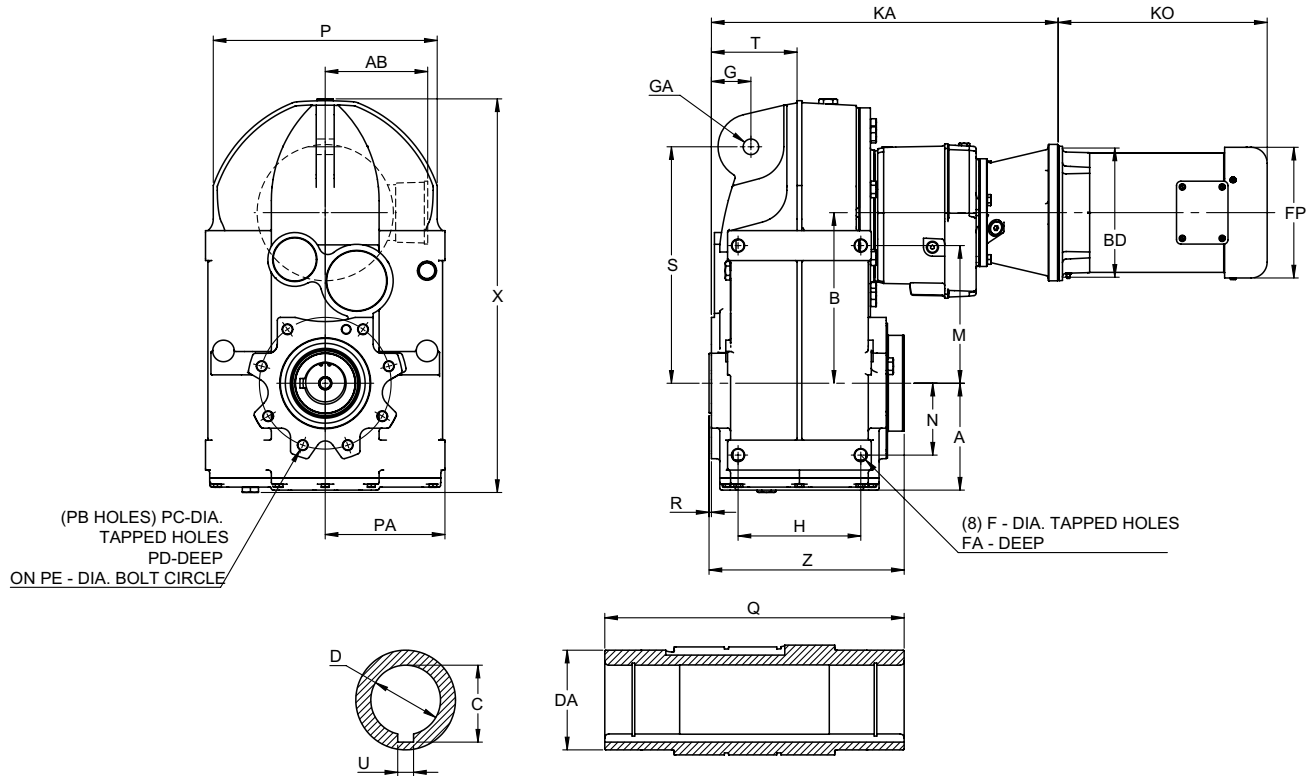

Type UJ Gearmotor — Straight Hollow — 300UJAJ (Dimensions-Inch)

Size	A	B	C	D	DA	F	FA	G	GA	H	M	N	P	PA	PB	PC	PD	PE	Q	R	S	T	U	X	Z
302	3.07	4.53	1.12	1.000 +0.0008, -0	1.77	M8	0.51	1.20	0.55	3.03	3.31	1.22	5.51	3.24	5.00	M8	0.51	3.70	4.72	0.08	6.22	2.24	0.25	10.47	5.17
302	3.07	4.53	1.37	1.250 +0.0010, -0	1.77	M8	0.51	1.20	0.55	3.03	3.31	1.22	5.51	3.24	5.00	M8	0.51	3.70	4.72	0.08	6.22	2.24	0.25	10.47	5.17
304	3.39	4.82	1.37	1.250 +0.0010, -0	1.97	M10	0.83	1.18	0.55	3.66	4.02	1.69	5.51	3.54	7.00	M8	0.51	4.72	5.91	0.08	6.69	2.89	0.25	11.16	6.35
304	3.39	4.82	1.52	1.375 +0.0010, -0	1.97	M10	0.83	1.18	0.55	3.66	4.02	1.69	5.51	3.54	7.00	M8	0.51	4.72	5.91	0.08	6.69	2.89	0.31	11.16	6.35
306	4.11	6.84	1.67	1.500 +0.0010, -0	2.17	M12	0.71	1.54	0.55	4.41	5.19	2.36	7.40	4.17	6.00	M12	0.71	4.92	7.09	0.08	8.58	3.52	0.38	14.82	7.62
307	4.89	8.61	2.23	2.000 +0.0012, -0	2.76	M16	1.02	1.87	0.87	5.51	6.69	2.76	10.63	5.31	8.00	M12	0.87	5.59	8.27	0.10	10.94	3.98	0.50	18.90	8.78
308	5.93	9.47	2.66	2.375 +0.0012, -0	3.35	M16	1.02	2.34	0.87	6.50	8.27	3.94	11.38	6.50	6.00	M16	1.02	7.01	9.45	0.10	13.62	4.70	0.63	21.11	10.06
309	7.03	11.22	3.04	2.750 +0.0012, -0	3.94	M20	1.10	2.60	1.02	8.07	9.06	4.72	14.72	7.87	8.00	M16	1.22	8.66	11.81	0.16	15.55	5.63	0.63	25.89	12.83
310	7.70	13.27	3.59	3.250 +0.0014, -0	4.72	M24	1.42	2.83	1.02	8.66	10.83	4.92	15.98	8.86	8.00	M20	1.18	10.24	13.78	0.63	19.09	6.28	0.75	29.51	14.33
312	8.66	14.57	4.45	4.000 +0.0014, -0	5.51	M30	1.77	3.74	1.30	10.63	15.67	5.59	17.64	10.43	11.00	M20	1.10	11.81	16.14	0.59	3.74	7.60	1.00	34.11	16.73

NEMA C-FACE INPUT — Quadruple & Quintuple Reduction (Dimensions-Inch)

Frame Size	DRIVE SIZE											
	All Sizes				KA							
	AB	BD	FP	K0	302	304	306	307	308	309	310	312
56C	5.25	6.50	7.19	9.32	14.47	15.28	15.71	16.97	17.81	21.01	22.23	26.09
142TC/145TC	5.25	6.50	7.19	12.07	14.47	15.28	15.71	16.97	17.81	21.01	22.23	26.09
182TC/184TC	5.88	9.00	8.50	15.43	15.37	16.18	16.61	17.87	18.72	22.80	24.02	27.88
213TC/215TC	7.38	9.00	10.19	16.31	—	—	—	—	—	22.80	24.02	27.88

300UJ — Double & Triple Reduction Gearmotor/Hollow Shaft with TA Taper Bushing

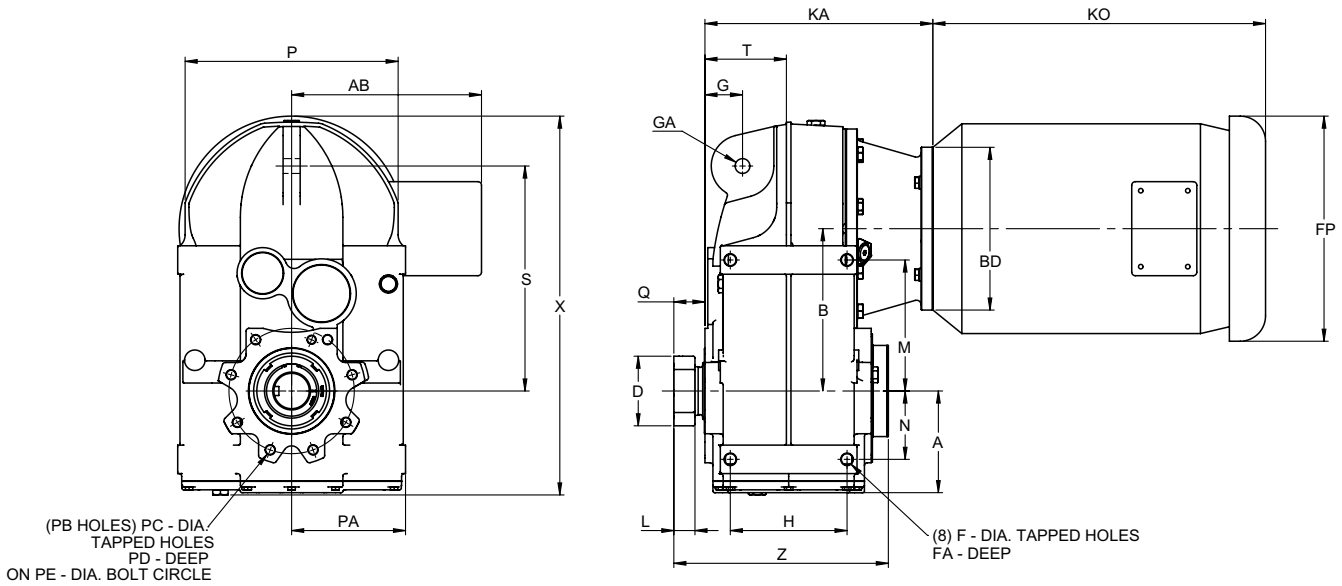

Type UJ Gearmotor — Hollow Shaft with TA Taper Bushing — 300UJAN (Dimensions—Inch)

Size*	A	B	D	F	FA	G	GA	H	L	M	N	P	PA	PB	PC	PD	PE	Q	S	T	X	Z
306	4.11	6.84	3.31	M12	0.71	1.54	0.55	4.41	1.26	5.19	2.36	7.40	4.17	6.00	M12	0.71	4.92	1.85	8.58	3.52	14.82	9.40
307	4.89	8.61	4.06	M16	1.02	1.87	0.87	5.51	1.46	6.69	2.76	10.63	5.31	8.00	M12	0.87	5.59	2.13	10.94	3.98	18.90	10.76
308	5.93	9.47	4.81	M16	1.02	2.34	0.87	6.50	1.46	8.27	3.94	11.38	6.50	6.00	M16	1.02	7.01	2.15	13.62	4.70	21.11	12.11
309	7.03	11.22	4.81	M20	1.10	2.60	1.02	8.07	1.46	9.06	4.72	14.72	7.87	8.00	M16	1.22	8.66	2.15	15.55	5.63	25.89	14.83
310	7.70	13.27	6.06	M24	1.42	2.83	1.02	8.66	1.76	10.83	4.92	15.98	8.86	8.00	M20	1.18	10.24	2.55	19.09	6.28	29.51	16.25
312	8.66	14.57	6.81	M30	1.77	3.74	1.30	10.63	1.80	15.67	5.59	17.64	10.43	11.00	M20	1.10	11.81	2.64	3.74	7.60	34.85	18.78

★ For Hollow L.S. Shaft Dimensions, refer to TA Taper Bushing Dimensions on pages 40-41.

NEMA C-FACE INPUT — Double & Triple Reduction (Dimensions—Inch)

Frame Size	Drive Size											
	All Sizes				KA							
	AB	BD	FP	K0	302	304	306	307	308	309	310	312
56C	5.25	6.50	7.19	9.32	7.80	8.60	9.04	10.30	11.14	-	-	-
142TC/145TC	5.25	6.50	7.19	12.07	7.80	8.60	9.04	10.30	11.14	-	-	-
182TC/184TC	5.88	9.00	8.50	15.43	8.70	9.51	10.83	12.09	12.93	-	-	-
213TC/215TC	7.38	9.00	10.19	16.31	-	-	10.83	12.09	12.93	14.13	15.35	19.21
254TC/256TC	9.63	10.00	12.50	19.88	-	-	-	13.56	14.41	15.61	16.83	20.69
284TC/286TC	13.13	11.25	15.56	23.18	-	-	-	-	-	15.75	16.97	20.83
324TC/326TC	14.13	13.38	16.94	25.25	-	-	-	-	-	17.36	18.58	22.44

300UJ — Quadruple & Quintuple Reduction Gearmotor/Hollow Shaft with TA Taper Bushing

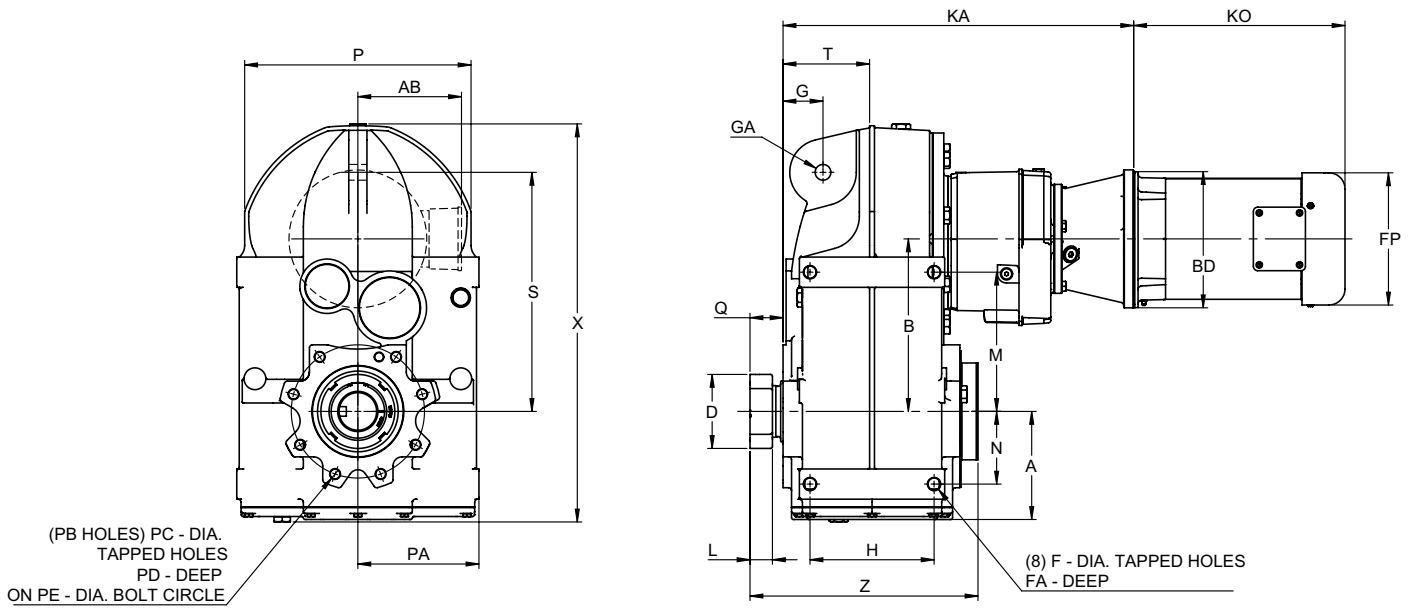

Type UJ Gearmotor — Hollow Shaft with TA Taper Bushing — 300UJAN (Dimensions-Inch)

Size*	A	B	D	F	FA	G	GA	H	L	M	N	P	PA	PB	PC	PD	PE	Q	S	T	X	Z
306	4.11	6.84	3.31	M12	0.71	1.54	0.55	4.41	1.26	5.19	2.36	7.40	4.17	6.00	M12	0.71	4.92	1.85	8.58	3.52	14.82	9.40
307	4.89	8.61	4.06	M16	1.02	1.87	0.87	5.51	1.46	6.69	2.76	10.63	5.31	8.00	M12	0.87	5.59	2.13	10.94	3.98	18.90	10.76
308	5.93	9.47	4.81	M16	1.02	2.34	0.87	6.50	1.46	8.27	3.94	11.38	6.50	6.00	M16	1.02	7.01	2.15	13.62	4.70	21.11	12.11
309	7.03	11.22	4.81	M20	1.10	2.60	1.02	8.07	1.46	9.06	4.72	14.72	7.87	8.00	M16	1.22	8.66	2.15	15.55	5.63	25.89	14.83
310	7.70	13.27	6.06	M24	1.42	2.83	1.02	8.66	1.76	10.83	4.92	15.98	8.86	8.00	M20	1.18	10.24	2.55	19.09	6.28	29.51	16.25
312	8.66	14.57	6.81	M30	1.77	3.74	1.30	10.63	1.80	15.67	5.59	17.64	10.43	11.00	M20	1.10	11.81	2.64	3.74	7.60	34.85	18.78

★ For Hollow L.S. Shaft Dimensions, refer to TA Taper Bushing Dimensions on pages 40-41.

NEMA C-FACE INPUT — Quadruple & Quintuple Reduction (Dimensions-Inch)

Frame Size	DRIVE SIZE											
	All Sizes				KA							
	AB	BD	FP	KO	302	304	306	307	308	309	310	312
56C	5.25	6.50	7.19	9.32	14.47	15.28	15.71	16.97	17.81	21.01	22.23	26.09
142TC/145TC	5.25	6.50	7.19	12.07	14.47	15.28	15.71	16.97	17.81	21.01	22.23	26.09
182TC/184TC	5.88	9.00	8.50	15.43	15.37	16.18	16.61	17.87	18.72	22.80	24.02	27.88
213TC/215TC	7.38	9.00	10.19	16.31	—	—	—	—	—	22.80	24.02	27.88

300UJ — Double & Triple Reduction Gearmotor/Inch Single-Ended

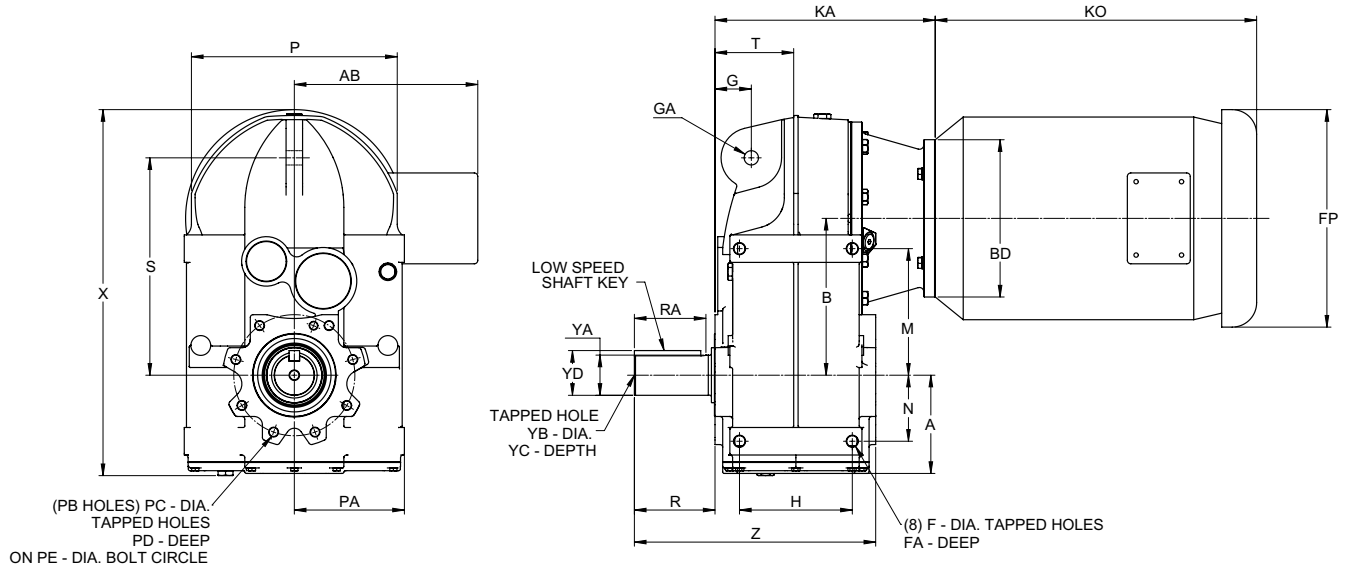

Type UJ Gearmotor — Solid Shaft Single-Ended — 300UJAK (Dimensions-Inch)

Size	A	B	F	FA	G	GA	H	M	N	P	PA	PB	PC	PD	PE	R	RA	S	T	X	Z
302	3.07	4.53	M8	0.51	1.20	0.55	3.03	3.31	1.22	5.51	3.24	5.00	M8	0.51	3.70	2.05	1.97	6.22	2.24	10.47	6.61
304	3.39	4.82	M10	0.83	1.18	0.55	3.66	4.02	1.69	5.51	3.54	7.00	M8	0.51	4.72	2.44	2.36	6.69	2.89	11.16	8.19
306	4.11	6.84	M12	0.71	1.54	0.55	4.41	5.19	2.36	7.40	4.17	6.00	M12	0.71	4.92	3.27	3.15	8.58	3.52	14.82	10.20
307	4.89	8.61	M16	1.02	1.87	0.87	5.51	6.69	2.76	10.63	5.31	8.00	M12	0.87	5.59	4.07	3.94	10.94	3.98	18.90	12.15
308	5.93	9.47	M16	1.02	2.34	0.87	6.50	8.27	3.94	11.38	6.50	6.00	M16	1.02	7.01	4.82	4.72	13.62	4.70	21.11	14.14
309	7.03	11.22	M20	1.10	2.60	1.02	8.07	9.06	4.72	14.72	7.87	8.00	M16	1.22	8.66	5.77	5.51	15.55	5.63	25.89	17.26
310	7.70	13.27	M24	1.42	2.83	1.02	8.66	10.83	4.92	15.98	8.86	8.00	M20	1.18	10.24	7.40	6.69	19.09	6.28	29.51	19.92
312	8.66	14.57	M30	1.77	3.74	1.30	10.63	15.67	5.59	17.64	10.43	11.00	M20	1.10	11.81	8.98	8.27	3.74	7.60	34.11	23.94

Size	Low Speed Shaft				
	YA	YB	YC	YD	Key
302	1.000 +0.000, -0.013	0.375-16 UNC-2B	1.375	1.11	0.25 x 0.25 x 1.75
304	1.250 +0.000, -0.013	0.375-16 UNC-2B	1.375	1.36	0.25 x 0.25 x 2.00
306	1.625 +0.000, -0.025	0.625-11 UNC-2B	1.875	1.79	0.375 x 0.375 x 2.50
307	2.000 +0.000, -0.025	0.750-10 UNC-2B	2.125	2.22	0.50 x 0.50 x 3.25
308	2.375 +0.000, -0.025	0.750-10 UNC-2B	2.125	2.65	0.625 x 0.625 x 4.0
309	2.875 +0.000, -0.025	0.750-10 UNC-2B	2.125	3.20	0.75 x 0.75 x 4.75
310	3.625 +0.000, -0.025	1.000-8 UNC-2B	2.625	4.01	0.875 x 0.875 x 5.75
312	4.375 +0.000, -0.025	1.000-8 UNC-2B	2.625	4.82	1.00 x 1.00 x 7.50

NEMA C-FACE INPUT — Double & Triple Reduction (Dimensions-Inch)

Frame Size	Drive Size											
	All Sizes				KA							
	AB	BD	FP	K0	302	304	306	307	308	309	310	312
56C	5.25	6.50	7.19	9.32	7.80	8.60	9.04	10.30	11.14	-	-	-
142TC/145TC	5.25	6.50	7.19	12.07	7.80	8.60	9.04	10.30	11.14	-	-	-
182TC/184TC	5.88	9.00	8.50	15.43	8.70	9.51	10.83	12.09	12.93	-	-	-
213TC/215TC	7.38	9.00	10.19	16.31	-	-	10.83	12.09	12.93	14.13	15.35	19.21
254TC/256TC	9.63	10.00	12.50	19.88	-	-	-	13.56	14.41	15.61	16.83	20.69
284TC/286TC	13.13	11.25	15.56	23.18	-	-	-	-	-	15.75	16.97	20.83
324TC/326TC	14.13	13.38	16.94	25.25	-	-	-	-	-	17.36	18.58	22.44

300UJ — Quadruple & Quintuple Reduction Gearmotor/Inch Single-Ended

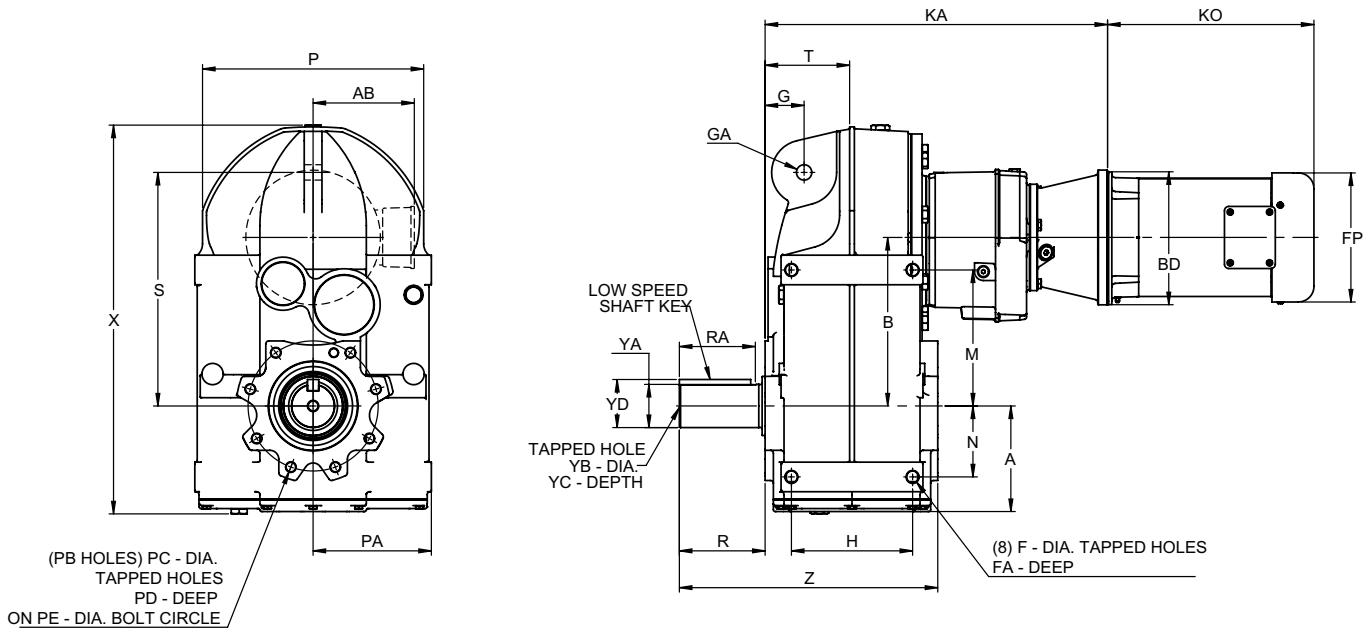

Type UJ Gearmotor — Solid Shaft Single-Ended — 300UJAK (Dimensions-Inch)

Size	A	B	F	FA	G	GA	H	M	N	P	PA	PB	PC	PD	PE	R	RA	S	T	X	Z
302	3.07	4.53	M8	0.51	1.20	0.55	3.03	3.31	1.22	5.51	3.24	5.00	M8	0.51	3.70	2.05	1.97	6.22	2.24	10.47	6.61
304	3.39	4.82	M10	0.83	1.18	0.55	3.66	4.02	1.69	5.51	3.54	7.00	M8	0.51	4.72	2.44	2.36	6.69	2.89	11.16	8.19
306	4.11	6.84	M12	0.71	1.54	0.55	4.41	5.19	2.36	7.40	4.17	6.00	M12	0.71	4.92	3.27	3.15	8.58	3.52	14.82	10.20
307	4.89	8.61	M16	1.02	1.87	0.87	5.51	6.69	2.76	10.63	5.31	8.00	M12	0.87	5.59	4.07	3.94	10.94	3.98	18.90	12.15
308	5.93	9.47	M16	1.02	2.34	0.87	6.50	8.27	3.94	11.38	6.50	6.00	M16	1.02	7.01	4.82	4.72	13.62	4.70	21.11	14.14
309	7.03	11.22	M20	1.10	2.60	1.02	8.07	9.06	4.72	14.72	7.87	8.00	M16	1.22	8.66	5.77	5.51	15.55	5.63	25.89	17.26
310	7.70	13.27	M24	1.42	2.83	1.02	8.66	10.83	4.92	15.98	8.86	8.00	M20	1.18	10.24	7.40	6.69	19.09	6.28	29.51	19.92
312	8.66	14.57	M30	1.77	3.74	1.30	10.63	15.67	5.59	17.64	10.43	11.00	M20	1.10	11.81	8.98	8.27	3.74	7.60	34.11	23.94

Size	Low Speed Shaft				
	YA	YB	YC	YD	Key
302	1.000 +0.000, -0.013	0.375-16 UNC-2B	1.375	1.11	0.25 x 0.25 x 1.75
304	1.250 +0.000, -0.013	0.375-16 UNC-2B	1.375	1.36	0.25 x 0.25 x 2.00
306	1.625 +0.000, -0.025	0.625-11 UNC-2B	1.875	1.79	0.375 x 0.375 x 2.50
307	2.000 +0.000, -0.025	0.750-10 UNC-2B	2.125	2.22	0.50 x 0.50 x 3.25
308	2.375 +0.000, -0.025	0.750-10 UNC-2B	2.125	2.65	0.625 x 0.625 x 4.0
309	2.875 +0.000, -0.025	0.750-10 UNC-2B	2.125	3.20	0.75 x 0.75 x 4.75
310	3.625 +0.000, -0.025	1.000-8 UNC-2B	2.625	4.01	0.875 x 0.875 x 5.75
312	4.375 +0.000, -0.025	1.000-8 UNC-2B	2.625	4.82	1.00 x 1.00 x 7.50

NEMA C-FACE INPUT — Quadruple & Quintuple Reduction (Dimensions-Inch)

Frame Size	DRIVE SIZE											
	All Sizes				KA							
	AB	BD	FP	KO	302	304	306	307	308	309	310	312
56C	5.25	6.50	7.19	9.32	14.47	15.28	15.71	16.97	17.81	21.01	22.23	26.09
142TC/145TC	5.25	6.50	7.19	12.07	14.47	15.28	15.71	16.97	17.81	21.01	22.23	26.09
182TC/184TC	5.88	9.00	8.50	15.43	15.37	16.18	16.61	17.87	18.72	22.80	24.02	27.88
213TC/215TC	7.38	9.00	10.19	16.31	—	—	—	—	—	22.80	24.02	27.88

300UJ — Double & Triple Reduction Gearmotor/Hollow Shaft with Shrink Disc

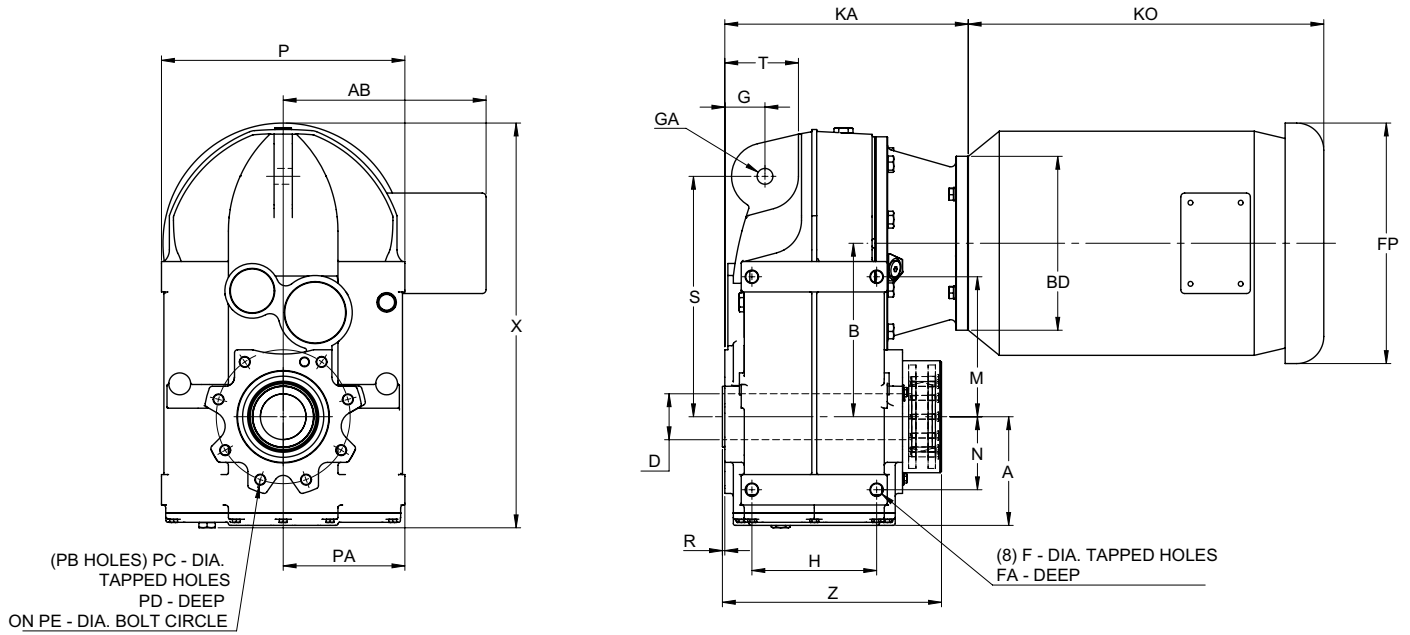

Type UJ Gearmotor — Hollow Shaft with Shrink Disc — 300UJAR (Dimensions—Inches)

Size*	A	B	D*	F	FA	G	GA	H	M	N	P	PA	PB	PC	PD	PE	R	S	T	X	Z
302	3.07	4.53	1.181	M8	0.51	1.20	0.55	3.03	3.31	1.22	5.51	3.25	0.20	M8	0.51	3.70	0.08	6.22	2.24	10.47	6.30
304	3.39	4.82	1.378	M10	0.83	1.18	0.55	3.66	4.02	1.69	5.51	3.54	0.28	M8	0.51	4.02	0.08	6.69	2.89	11.16	7.48
306	4.11	6.84	1.575	M12	0.71	1.54	0.55	4.41	5.12	2.36	7.40	4.17	0.24	M12	0.71	4.92	0.08	8.58	3.52	14.82	8.70
307	4.89	8.61	1.969	M16	1.02	1.87	0.87	5.51	6.69	2.76	10.63	5.31	0.31	M12	0.87	5.59	0.10	10.94	3.98	18.90	10.04
308	5.93	9.47	2.559	M16	1.02	2.34	0.87	6.50	8.27	3.94	11.38	6.50	0.24	M16	1.02	7.01	0.10	13.62	4.70	21.11	11.52
309	7.03	11.22	2.953	M20	1.10	2.60	1.02	8.07	9.06	4.72	14.72	7.87	0.31	M16	1.22	8.66	0.16	15.55	5.63	25.89	14.17
310	7.70	13.27	3.740	M24	1.42	2.83	1.02	8.66	10.83	4.92	15.98	8.86	0.31	M20	1.18	10.24	0.63	19.09	6.28	29.51	16.50
312	8.66	14.57	4.134	M30	1.77	3.74	1.30	10.63	15.67	5.59	17.64	10.43	0.43	M20	1.10	11.81	0.59	3.74	7.60	33.85	19.69

★ Refer to page 72 for shrink disc and driven shaft dimensions and recommendations.
 ■ See table on page 72 for tolerances.

NEMA C-FACE INPUT — Double & Triple Reduction (Dimensions—Inch)

Frame Size	Drive Size											
	All Sizes				KA							
	AB	BD	FP	K0	302	304	306	307	308	309	310	312
56C	5.25	6.50	7.19	9.32	7.80	8.60	9.04	10.30	11.14	-	-	-
142TC/145TC	5.25	6.50	7.19	12.07	7.80	8.60	9.04	10.30	11.14	-	-	-
182TC/184TC	5.88	9.00	8.50	15.43	8.70	9.51	10.83	12.09	12.93	-	-	-
213TC/215TC	7.38	9.00	10.19	16.31	-	-	10.83	12.09	12.93	14.13	15.35	19.21
254TC/256TC	9.63	10.00	12.50	19.88	-	-	-	13.56	14.41	15.61	16.83	20.69
284TC/286TC	13.13	11.25	15.56	23.18	-	-	-	-	-	15.75	16.97	20.83
324TC/326TC	14.13	13.38	16.94	25.25	-	-	-	-	-	17.36	18.58	22.44

300UJ — Quadruple & Quintuple Reduction Gearmotor/Hollow Shaft with Shrink Disc

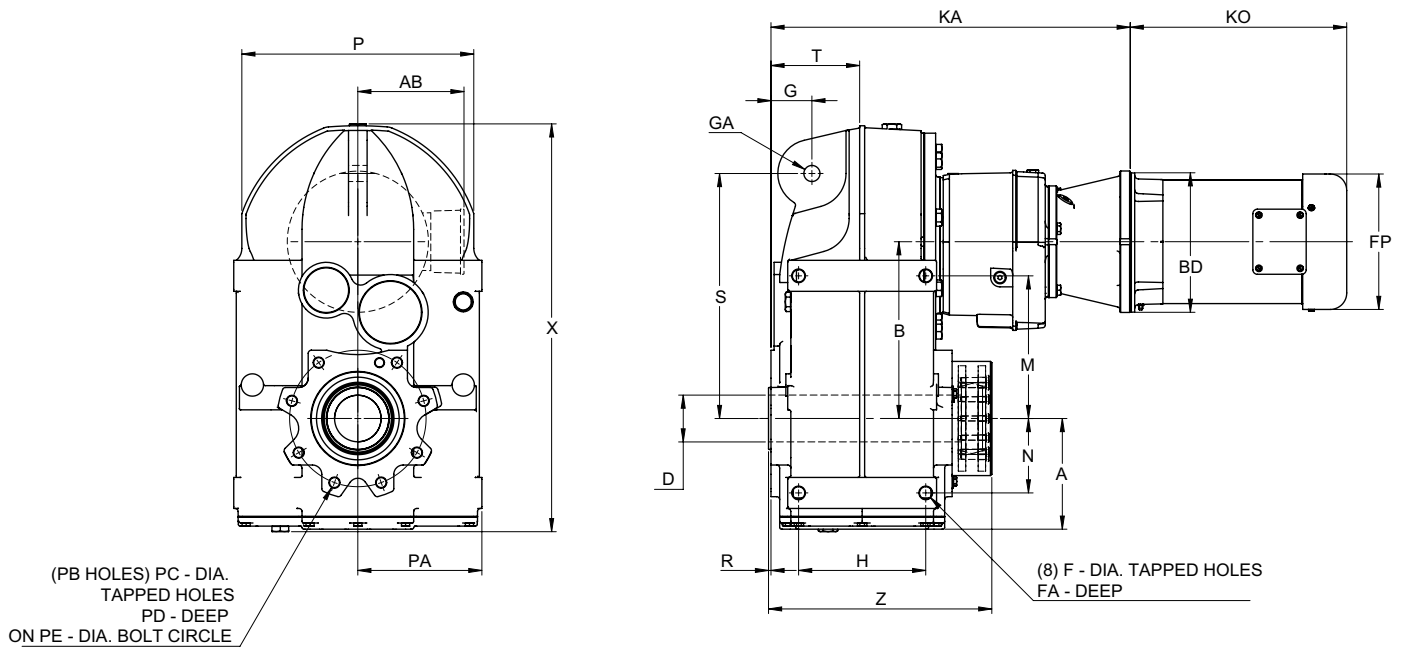

Type UJ Gearmotor — Hollow Shaft with Shrink Disc — 300UJAR (Dimensions—Inches)

Size*	A	B	D*	F	FA	G	GA	H	M	N	P	PA	PB	PC	PD	PE	R	S	T	X	Z
302	3.07	4.53	1.181	M8	0.51	1.20	0.55	3.03	3.31	1.22	5.51	3.25	0.20	M8	0.51	3.70	0.08	6.22	2.24	10.47	6.30
304	3.39	4.82	1.378	M10	0.83	1.18	0.55	3.66	4.02	1.69	5.51	3.54	0.28	M8	0.51	4.02	0.08	6.69	2.89	11.16	7.48
306	4.11	6.84	1.575	M12	0.71	1.54	0.55	4.41	5.12	2.36	7.40	4.17	0.24	M12	0.71	4.92	0.08	8.58	3.52	14.82	8.70
307	4.89	8.61	1.969	M16	1.02	1.87	0.87	5.51	6.69	2.76	10.63	5.31	0.31	M12	0.87	5.59	0.10	10.94	3.98	18.90	10.04
308	5.93	9.47	2.559	M16	1.02	2.34	0.87	6.50	8.27	3.94	11.38	6.50	0.24	M16	1.02	7.01	0.10	13.62	4.70	21.11	11.52
309	7.03	11.22	2.953	M20	1.10	2.60	1.02	8.07	9.06	4.72	14.72	7.87	0.31	M16	1.22	8.66	0.16	15.55	5.63	25.89	14.17
310	7.70	13.27	3.740	M24	1.42	2.83	1.02	8.66	10.83	4.92	15.98	8.86	0.31	M20	1.18	10.24	0.63	19.09	6.28	29.51	16.50
312	8.66	14.57	4.134	M30	1.77	3.74	1.30	10.63	15.67	5.59	17.64	10.43	0.43	M20	1.10	11.81	0.59	3.74	7.60	33.85	19.69

★ Refer to page 72 for shrink disc and driven shaft dimensions and recommendations.
 ■ See table on page 72 for tolerances.

NEMA C-FACE INPUT — Quadruple & Quintuple Reduction (Dimensions—Inch)

Frame Size	DRIVE SIZE											
	All Sizes				KA							
	AB	BD	FP	KO	302	304	306	307	308	309	310	312
56C	5.25	6.50	7.19	9.32	14.47	15.28	15.71	16.97	17.81	21.01	22.23	26.09
142TC/145TC	5.25	6.50	7.19	12.07	14.47	15.28	15.71	16.97	17.81	21.01	22.23	26.09
182TC/184TC	5.88	9.00	8.50	15.43	15.37	16.18	16.61	17.87	18.72	22.80	24.02	27.88
213TC/215TC	7.38	9.00	10.19	16.31	—	—	—	—	—	22.80	24.02	27.88

300UJ — Shaft-Mounted Gearmotor and Gear Drive/TA Taper Bushing — Inch

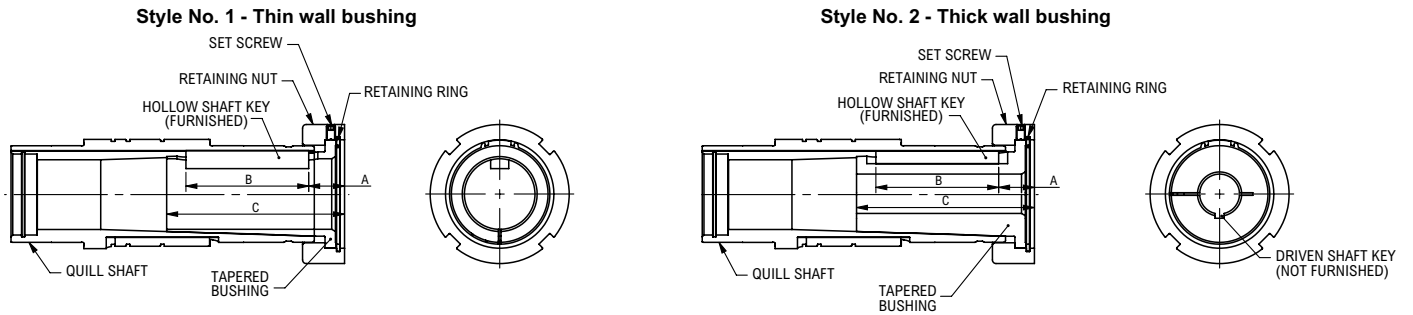

TA TAPER BUSHING 300UJAN / Dimensions—Inch

Drive Size	A	B	C Minimum Shaft Engagement	Bushing Size	Part Number ●	Style No.	Driven Shaft Keyway Min Key Length ▲	Wt (lb)
306UJ	1.89	2.50	5.00	1.000	10384592	2	0.250 x 0.125 x 2.500	3.6
				1.125	10384593	2	0.250 x 0.125 x 2.250	3.3
				1.188	10384594	2	0.250 x 0.125 x 2.000	3.2
				1.250	10384595	1	0.250 x 0.125 x 2.500	3.1
				1.375	10609765	1	0.375 x 0.188 x 2.500	2.8
307UJ	2.10	2.75	5.55	1.438	10384596	1	0.375 x 0.188 x 2.500	2.6
				1.188	10384597	2	0.250 x 0.125 x 4.250	6.8
				1.250	10384598	2	0.250 x 0.125 x 4.000	6.6
				1.438	10384599	2	0.375 x 0.188 x 2.250	6.0
				1.500	10384600	2	0.375 x 0.188 x 2.250	5.8
				1.625	10384601	1	0.375 x 0.188 x 2.750	5.5
				1.688	10384602	1	0.375 x 0.188 x 2.750	5.3
				1.750	10384603	1	0.375 x 0.188 x 2.750	5.0
				1.875	10611062	1	0.500 x 0.250 x 2.750	4.5
				1.938	10384604	1	0.500 x 0.250 x 2.750	4.2
308UJ	1.24	4.25	6.11	1.375	10384614	2	0.188 x 0.156 x 5.750	11.0
				1.438	10384615	2	0.375 x 0.188 x 5.750	10.8
				1.500	10384616	2	0.375 x 0.188 x 5.750	10.6
				1.625	10384617	2	0.375 x 0.188 x 5.750	10.1
				1.688	10384618	2	0.375 x 0.188 x 5.250	9.8
				1.750	10384619	2	0.375 x 0.188 x 5.250	9.5
				1.875	10384620	2	0.500 x 0.250 x 3.500	8.9
				1.938	10384621	1	0.500 x 0.250 x 4.250	8.9
				2.000	10384622	1	0.500 x 0.250 x 4.250	8.6
				2.188	10384623	1	0.500 x 0.250 x 4.250	7.6
				2.250	10384624	1	0.500 x 0.250 x 4.250	7.3
				2.375	10384625	1	0.625 x 0.313 x 4.250	6.6
				2.438	10384626	1	0.625 x 0.313 x 4.250	6.2
309UJ	1.24	4.25	6.11	1.375	10384614	2	0.188 x 0.156 x 5.750	11.0
				1.438	10384615	2	0.375 x 0.188 x 5.750	10.8
				1.500	10384616	2	0.375 x 0.188 x 5.750	10.6
				1.625	10384617	2	0.375 x 0.188 x 5.750	10.1
				1.688	10384618	2	0.375 x 0.188 x 5.250	9.8
				1.750	10384619	2	0.375 x 0.188 x 5.250	9.5
				1.875	10384620	2	0.500 x 0.250 x 3.500	8.9
				1.938	10384621	1	0.500 x 0.250 x 4.250	8.9
				2.000	10384622	1	0.500 x 0.250 x 4.250	8.6
				2.188	10384623	1	0.500 x 0.250 x 4.250	7.6
				2.250	10384624	1	0.500 x 0.250 x 4.250	7.3
				2.375	10384625	1	0.625 x 0.313 x 4.250	6.6
				2.438	10603381	1	0.625 x 0.313 x 4.250	6.2
				310UJ	1.59	5.00	7.39	2.000
2.188	10384637	2	0.500 x 0.250 x 7.000					22.3
2.250	10384638	2	0.500 x 0.250 x 7.000					21.9
2.438	10384639	2	0.625 x 0.313 x 5.500					20.4
2.500	10384640	2	0.625 x 0.313 x 5.000					19.9
2.688	10384641	1	0.625 x 0.313 x 5.000					19.1
2.750	10603382	1	0.750 x 0.375 x 5.000					18.7
2.938	10384642	1	0.750 x 0.375 x 5.000					17.1
3.000	10384643	1	0.750 x 0.375 x 5.000					16.5
3.188	10384644	1	0.750 x 0.375 x 5.000					14.7
312UJ	1.88	5.00	7.92	3.438	10384645	1	0.875 x 0.438 x 5.000	12.2
				2.438	10384646	2	0.625 x 0.313 x 7.500	30.7
				2.500	10384647	2	0.625 x 0.313 x 7.500	30.2
				2.688	10384648	2	0.625 x 0.313 x 7.500	28.5
				2.938	10384649	2	0.750 x 0.375 x 5.500	26.0
				3.000	10384651	2	0.750 x 0.375 x 5.500	25.4
				3.438	10384652	1	0.875 x 0.438 x 5.000	21.9
3.938	10384653	1	1.000 x 0.500 x 5.000	15.8				

● Consists of bushing, drive key, nut, retaining ring and setscrew.

▲ Check strength of driven shaft and unfurnished key.

300UJ — Shaft-Mounted Gearmotor and Gear Drive/TA Taper Bushing — Metric

Style No. 1 - Thin wall bushing

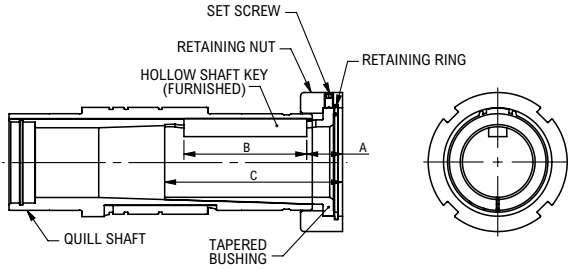

Style No. 2 - Thick wall bushing

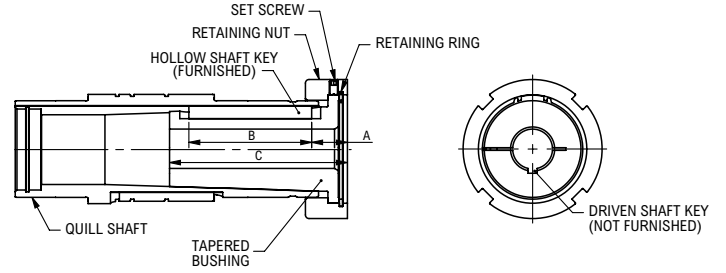

TA TAPER BUSHING 300UJAN / Dimensions—Metric

Drive Size	A	B	C Minimum Shaft Engagement	Bushing Size	Part Number ●	Style No.	Driven Shaft Keyway Min Key Length ▲	Wt (kg)
306UJ	48	64	127	25	10384654	2	8 x 4 x 70	1.6
				30	10384655	2	8 x 4 x 56	1.4
				32	10384656	1	10 x 5 x 74	1.4
				35	10384657	1	10 x 5 x 74	1.2
307UJ	53	70	141	30	10384658	2	8 x 4 x 110	3.1
				32	10384659	2	10 x 5 x 110	3.0
				35	10384660	2	10 x 5 x 100	2.8
				38	10384661	2	10 x 5 x 90	2.6
				40	10384662	1	12 x 5 x 82	2.6
				42	10384663	1	12 x 5 x 82	2.4
308UJ	32	108	155	45	10384664	1	14 x 5.5 x 84	2.2
				40	10384672	2	12 x 5 x 160	4.7
				42	10384673	2	12 x 5 x 160	4.5
				45	10384674	2	14 x 5.5 x 160	4.3
				50	10384675	1	14 x 5.5 x 122	4.0
309UJ	32	108	155	55	10384676	1	16 x 6 x 124	3.5
				60	10384677	1	18 x 7 x 126	3.0
				40	10384672	2	12 x 5 x 160	4.7
				42	10384673	2	12 x 5 x 160	4.5
				45	10384674	2	14 x 5.5 x 160	4.3
				50	10384675	1	14 x 5.5 x 122	4.0
310UJ	40	127	188	55	10384676	1	16 x 6 x 124	3.5
				60	10384677	1	18 x 7 x 126	3.0
				60	10384684	2	18 x 7 x 180	9.6
				65	10384685	2	18 x 7 x 180	8.9
				70	10384686	1	20 x 7.7 x 147	8.4
				75	10384687	1	20 x 7.7 x 147	7.6
312UJ	40	127	188	80	10384688	1	22 x 9 x 149	6.8
				85	10384689	1	22 x 9 x 149	5.9
				70	10384690	2	20 x 7.5 x 200	12.7
				75	10384691	2	20 x 7.5 x 200	11.8
				80	10384692	2	22 x 9 x 200	10.9
				85	10384693	1	22 x 9 x 149	10.3
				90	10384694	1	25 x 9 x 152	9.3
95	10384695	1	25 x 9 x 152	8.2				
				100	10384696	1	28 x 10 x 155	7.1

- Consists of bushing, drive key, nut, retaining ring and setscrew.
- ▲ Check strength of driven shaft and unfurnished key.

300UJ — Overhung Loads

High-Speed and Low-Speed Shaft

Overhung load is imposed upon a shaft when a pinion, sprocket or sheave is used as a power take-off. The magnitude of the load varies with the type of take-off and its proximity to the shaft bearing. Calculate the load and check the result against the tabulated overhung load rating.

Overhung Load Formula:

$$\text{Overhung Load} = \frac{126,000 \times \text{hp} \times F_c \times L_f}{\text{pitch diameter} \times \text{RPM}}$$

F_c = Load Connection Factor

Sprocket or Timing Belt	1.00
Machined Pinion & Gear	1.25
V-Belt	1.50
Flat Belt	2.50

L_f = Load Location Factor

L_f load location factors tabulated below are based on the distance from the center line of the load to the end of the shaft. For overhung loads applied at the midpoint of the usable shaft extension, L_f = 1.00

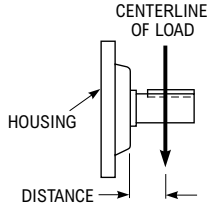

Locate the centerline of the load as practical to minimize the overhung load and increase bearing life. The above overhung load formula employs the transmitted horsepower, without Service Factor, providing the overloads, starting loads and brake capacities do not exceed the amounts listed in Basic Information on page 4.

Consult Factory for Higher Overhung Load Ratings — In many cases, overhung load capacity in excess of that published is available. Published ratings are based on a combination of the most unfavorable conditions of rotation, speed, direction of applied load and drive loading. If the actual load should exceed the published capacity, refer full details to Factory; provide complete application information, as well as direction of rotation, location and direction of applied load.

Gearmotor Overhung Load Capacity —

Low Speed Shaft: The overhung load capacity at the low-speed shaft is found in the Gearmotor Selection Tables on next pages.

High Speed Shaft: Consult Factory.

Example

Gear Drive Size = 304UJAQ2A56A_B, exact ratio of 59.95:1

Motor: 1.0 hp at 1750 rpm

Low speed shaft rpm = 1750 ÷ 59.95 = 29.2 rpm.

3" diameter sprocket mounted on low-speed shaft. Centerline of sprocket overhung load is positioned at B = 1.5 inches. Calculate the overhung load as follows:

$$\text{OHL} = \frac{126,000 \times 1.0 \times 1.00 \times 0.94}{3 \times 29.2} = 1352 \text{ lb}$$

Allowable OHL on page 43 is 1550 lb and is satisfactory for this selection.

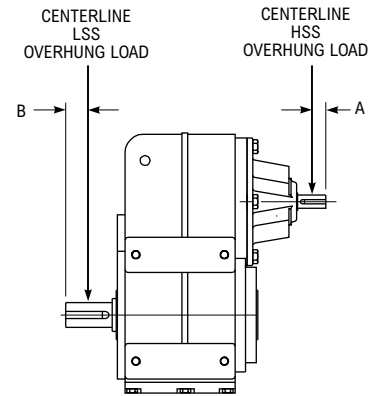

LSS L_f Load Location Factors▲ (Dimensions—Inches) Based on distance from centerline of load to end of shaft

Distance "B" Dimension (inch)	DOUBLE & TRIPLE REDUCTION DRIVE SIZE							
	302	304	306	307	308	309	310	312
0.0	1.55	1.45	1.47	1.48	1.49	1.50	1.51	1.56
0.5	1.27	1.26	1.32	1.35	1.39	1.41	1.43	1.49
1.0	1.00	1.07	1.17	1.23	1.28	1.32	1.36	1.42
1.5	0.89	0.94	1.02	1.11	1.18	1.23	1.28	1.35
2.0	0.79	0.86	0.94	1.00	1.08	1.14	1.21	1.29
2.5		0.77	0.87	0.93	0.99	1.05	1.13	1.22
3.0			0.80	0.87	0.93	0.98	1.05	1.15
3.5				0.81	0.88	0.94	0.99	1.09
4.0					0.82	0.90	0.95	1.02
4.5					0.77	0.85	0.92	0.98
5.0						0.81	0.88	0.94
5.5						0.77	0.85	0.91
6.0							0.81	0.88
6.5							0.78	0.84
7.0								0.81
7.5								0.78
8.0								0.74

▲ Interpolate for intermediate values

300UJ — Gear Drive LSS Overhung Load Ratings

1750 High-Speed Shaft RPM/Double Reduction (Pounds at Low-Speed Shaft)

Ratio Code	Approx L.S. Shaft RPM	Overhung Load Capacity - lbs							
		Drive Size							
		302	304	306	307	308	309	310	312
3.1	556	—	—	2,000	2,300	2,900	4,000	5,600	—
3.5	493	560	—	2,050	2,350	2,950	4,300	5,700	—
4.0	438	560	—	2,050	2,350	2,950	4,200	5,800	—
4.5	389	560	1,550	2,100	2,450	3,000	4,300	5,800	—
5.0	350	570	1,550	2,200	2,450	3,100	4,300	5,800	—
5.6	313	550	1,550	2,300	2,550	3,100	4,300	6,000	—
6.3	278	570	1,550	2,400	2,650	3,100	4,300	6,000	—
7.1	246	600	1,550	2,400	2,750	3,400	4,400	5,600	—
8.0	219	620	1,550	2,500	2,750	3,400	4,400	5,600	—
9.0	194	620	1,550	2,500	2,800	3,600	4,600	5,800	—
10.	175	630	1,550	2,650	2,800	3,600	4,600	5,900	—
11.	156	660	1,550	2,750	2,900	3,700	4,700	6,200	—
12.	140	700	1,550	2,900	3,000	3,900	4,900	6,300	—
14.	125	760	1,550	2,900	3,100	4,000	5,000	6,500	—
16.	109	800	1,550	2,950	3,200	4,200	5,100	6,700	—
18.	97.2	850	1,550	3,000	3,400	4,400	5,300	7,000	—
20.	87.5	900	1,550	3,000	3,500	4,500	5,400	7,200	—
22.	78.1	940	1,550	3,000	3,500	4,600	5,600	7,400	—
25.	70.0	1,000	1,550	3,000	3,700	5,100	5,700	7,600	—
28.	62.5	1,050	1,550	3,000	3,800	5,100	5,900	7,900	—
31.	55.6	1,100	1,550	3,000	3,900	5,100	6,100	8,100	—
35.	49.3	1,100	1,550	3,000	4,000	5,300	6,400	8,500	—
40.	43.8	1,100	1,550	3,000	4,000	5,400	6,600	8,800	—
45.	38.9	1,100	1,550	3,000	4,000	5,700	6,700	9,200	—
50.	35.0	1,100	1,550	3,000	4,000	5,800	6,700	9,400	—
56.	31.3	1,100	1,550	3,000	4,000	6,000	6,700	10,000	—
63.	27.8	1,100	1,550	3,000	4,000	—	6,700	—	—
71.	24.6	1,100	1,550	3,000	4,000	—	6,700	—	—
80.	21.9	1,100	1,550	3,000	—	—	—	—	—
90.	19.4	1,100	1,550	3,000	—	—	—	—	—
100	17.5	—	1,550	3,000	—	—	—	—	—

1750 High-Speed Shaft RPM/Triple Reduction (Pounds at Low-Speed Shaft)

Ratio Code	Approx L.S. Shaft RPM	Overhung Load Capacity - lbs							
		Drive Size							
		302	304	306	307	308	309	310	312
8.0	219	—	—	—	—	—	—	—	6,730
9.0	194	—	—	—	—	—	—	—	7,015
10.	175	—	—	—	—	—	—	—	7,015
11.	156	—	—	—	—	—	—	—	7,308
12.	140	—	—	—	—	—	—	—	7,308
14.	125	—	—	—	—	—	—	—	7,300
16.	109	—	—	—	—	—	—	—	7,493
18.	97.2	—	—	—	—	—	—	—	7,879
20.	87.5	—	—	—	—	—	—	—	8,264
22.	78.1	—	—	—	—	—	—	—	8,364
25.	70.0	—	—	—	—	—	—	—	9,635
28.	62.5	—	—	—	—	—	—	—	10,213
31.	55.6	—	—	—	—	—	—	—	10,791
35.	49.3	—	—	—	4,000	6,100	—	—	10,984
40.	43.8	—	—	—	4,000	6,100	6,700	9,700	11,754
45.	38.9	—	—	—	4,000	6,100	6,700	10,000	12,332
50.	35.0	—	—	—	4,000	6,100	6,700	10,500	11,803
56.	31.3	—	—	—	4,000	6,100	6,700	10,500	12,674
63.	27.8	—	—	—	4,000	6,100	6,700	11,000	13,945
71.	24.6	—	—	—	4,000	6,100	6,700	11,200	14,523
80.	21.9	—	—	—	4,000	6,100	6,700	11,200	15,601
90.	19.4	—	—	—	4,000	6,100	6,700	11,200	16,764
100	17.5	—	—	—	4,000	6,100	6,700	11,200	17,535
112	15.6	—	—	—	4,000	6,100	6,700	11,200	18,691
125	14.0	—	—	—	4,000	6,100	6,700	11,200	19,077
140	12.5	—	—	—	4,000	6,100	6,700	11,200	—
160	10.9	—	—	—	4,000	6,100	6,700	11,200	—
180	9.7	—	—	—	4,000	6,100	6,700	11,200	—
200	8.8	—	—	—	4,000	6,100	6,700	11,200	—
224	7.8	—	—	—	4,000	6,100	6,700	11,200	—
250	7.0	—	—	—	—	6,100	6,700	11,200	—
280	6.3	—	—	—	—	6,100	6,700	11,200	—
315	5.6	—	—	—	—	6,100	6,700	—	—

300UJ — Gear Drive LSS Overhung Load Ratings

1750 High-Speed Shaft RPM/Quadruple and Quintuple Reduction (Pounds at Low-Speed Shaft)

Ratio Code	Approx L.S. Shaft RPM	Overhung Load Capacity - lbs							
		Drive Size							
		302	304	306	307	308	309	310	312
100	17.5	1,100	1,550	3,000	—	—	—	—	—
112	15.6	1,100	1,550	3,000	—	—	—	—	—
125	14.0	1,100	1,550	3,000	—	—	—	—	—
140	12.5	1,100	1,550	3,000	—	—	—	—	—
160	10.9	1,100	1,550	3,000	—	—	—	—	—
180	9.7	1,100	1,550	3,000	4,000	—	—	—	19,077
200	8.8	1,100	1,550	3,000	4,000	—	—	—	19,077
224	7.8	1,100	1,550	3,000	4,000	—	—	—	19,077
250	7.0	1,100	1,550	3,000	4,000	—	—	—	19,077
280	6.3	1,100	1,550	3,000	4,000	6,100	6,700	11,200	19,077
315	5.6	1,100	1,550	3,000	4,000	6,100	6,700	11,200	19,077
355	4.9	1,100	1,550	3,000	4,000	6,100	6,700	11,200	19,077
400	4.4	1,100	1,550	3,000	4,000	6,100	6,700	11,200	19,077
450	3.9	1,100	1,550	3,000	4,000	6,100	6,700	11,200	19,077
500	3.5	1,100	1,550	3,000	4,000	6,100	6,700	11,200	19,077
560	3.1	1,100	1,550	3,000	4,000	6,100	6,700	11,200	19,077
630	2.8	1,100	1,550	3,000	4,000	6,100	6,700	11,200	19,077
710	2.5	1,100	1,550	3,000	4,000	6,100	6,700	11,200	19,077
800	2.2	1,100	1,550	3,000	4,000	6,100	6,700	11,200	19,077
900	1.9	—	1,550	3,000	4,000	6,100	6,700	11,200	19,077
1000 (10C)	1.8	—	—	3,000	4,000	6,100	6,700	11,200	19,077
1120 (11C)	1.6	—	—	—	4,000	6,100	—	11,200	19,077

300UJ — Gear Drive LSS Overhung Load Ratings

1430 High-Speed Shaft RPM/Double Reduction (Pounds at Low-Speed Shaft)

Ratio Code	Approx L.S. Shaft RPM	Overhung Load Capacity - lbs							
		Drive Size							
		302	304	306	307	308	309	310	312
3.1	454	—	—	2,100	2,450	3,000	4,300	5,800	—
3.5	403	580	—	2,150	2,450	3,100	4,500	6,000	—
4.0	358	580	—	2,200	2,500	3,100	4,400	6,100	—
4.5	318	600	1,550	2,200	2,550	3,200	4,500	6,100	—
5.0	286	610	1,550	2,300	2,600	3,200	4,500	6,200	—
5.6	255	580	1,550	2,400	2,700	3,300	4,500	6,300	—
6.3	227	610	1,550	2,500	2,750	3,300	4,500	6,300	—
7.1	201	630	1,550	2,550	2,900	3,600	4,600	5,800	—
8.0	179	650	1,550	2,600	2,850	3,600	4,600	5,800	—
9.0	159	650	1,550	2,650	2,950	3,800	4,800	6,100	—
10.	143	660	1,550	2,800	2,900	3,800	4,800	6,200	—
11.	128	700	1,550	2,900	3,100	3,900	4,900	6,500	—
12.	114	740	1,550	3,000	3,200	4,100	5,200	6,600	—
14.	102	800	1,550	3,000	3,300	4,300	5,300	6,900	—
16.	89.4	840	1,550	3,000	3,400	4,400	5,400	7,100	—
18.	79.4	900	1,550	3,000	3,600	4,600	5,600	7,400	—
20.	71.5	940	1,550	3,000	3,700	4,700	5,700	7,600	—
22.	63.8	1,000	1,550	3,000	3,800	4,900	5,800	7,900	—
25.	57.2	1,050	1,550	3,000	3,900	5,300	6,000	8,100	—
28.	51.1	1,100	1,550	3,000	4,000	5,400	6,200	8,300	—
31.	45.4	1,100	1,550	3,000	4,000	5,400	6,400	8,500	—
35.	40.3	1,100	1,550	3,000	4,000	5,600	6,700	9,100	—
40.	35.8	1,100	1,550	3,000	4,000	5,700	6,700	9,400	—
45.	31.8	1,100	1,550	3,000	4,000	6,000	6,700	9,800	—
50.	28.6	1,100	1,550	3,000	4,000	6,100	6,700	10,000	—
56.	25.5	1,100	1,550	3,000	4,000	6,100	6,700	10,500	—
63.	22.7	1,100	1,550	3,000	4,000	—	6,700	—	—
71.	20.1	1,100	1,550	3,000	4,000	—	6,700	—	—
80.	17.9	1,100	1,550	3,000	—	—	—	—	—
90.	15.9	1,100	1,550	3,000	—	—	—	—	—
100	14.3	—	1,550	3,000	—	—	—	—	—

1430 High-Speed Shaft RPM/Triple Reduction (Pounds at Low-Speed Shaft)

Ratio Code	Approx L.S. Shaft RPM	Overhung Load Capacity - lbs							
		Drive Size							
		302	304	306	307	308	309	310	312
8.0	219	—	—	—	—	—	—	—	8,318
9.0	194	—	—	—	—	—	—	—	8,768
10.	175	—	—	—	—	—	—	—	8,768
11.	156	—	—	—	—	—	—	—	8,992
12.	140	—	—	—	—	—	—	—	8,992
14.	125	—	—	—	—	—	—	—	9,217
16.	109	—	—	—	—	—	—	—	9,442
18.	97.2	—	—	—	—	—	—	—	9,892
20.	87.5	—	—	—	—	—	—	—	10,341
22.	78.1	—	—	—	—	—	—	—	10,341
25.	70.0	—	—	—	—	—	—	—	11,240
28.	62.5	—	—	—	—	—	—	—	11,915
31.	55.6	—	—	—	—	—	—	—	12,589
35.	40.3	—	—	—	4,000	6,100	—	—	12,814
40.	35.8	—	—	—	4,000	6,100	6,700	11,000	13,713
45.	31.8	—	—	—	4,000	6,100	6,700	11,200	14,388
50.	28.6	—	—	—	4,000	6,100	6,700	11,200	15,287
56.	25.5	—	—	—	4,000	6,100	6,700	11,200	16,186
63.	22.7	—	—	—	4,000	6,100	6,700	11,200	17,085
71.	20.1	—	—	—	4,000	6,100	6,700	11,200	17,760
80.	17.9	—	—	—	4,000	6,100	6,700	11,200	18,434
90.	15.9	—	—	—	4,000	6,100	6,700	11,200	19,558
100	14.3	—	—	—	4,000	6,100	6,700	11,200	20,458
112	12.8	—	—	—	4,000	6,100	6,700	11,200	21,806
125	11.4	—	—	—	4,000	6,100	6,700	11,200	22,200
140	10.2	—	—	—	4,000	6,100	6,700	11,200	—
160	8.9	—	—	—	4,000	6,100	6,700	11,200	—
180	7.9	—	—	—	4,000	6,100	6,700	11,200	—
200	7.2	—	—	—	4,000	6,100	6,700	11,200	—
224	6.4	—	—	—	4,000	6,100	6,700	11,200	—
250	5.7	—	—	—	—	6,100	6,700	11,200	—
280	5.1	—	—	—	—	6,100	6,700	11,200	—
315	4.5	—	—	—	—	6,100	6,700	—	—

300UJ — Gear Drive LSS Overhung Load Ratings

1430 High-Speed Shaft RPM/Quadruple and Quintuple Reduction (Pounds at Low-Speed Shaft)

Ratio Code	Approx L.S. Shaft RPM	Overhung Load Capacity - lbs							
		Drive Size							
		302	304	306	307	308	309	310	312
100	14.3	1,100	1,550	3,000	—	—	—	—	—
112	12.8	1,100	1,550	3,000	—	—	—	—	—
125	11.4	1,100	1,550	3,000	—	—	—	—	—
140	10.2	1,100	1,550	3,000	—	—	—	—	—
160	8.9	1,100	1,550	3,000	—	—	—	—	—
180	7.9	1,100	1,550	3,000	4,000	—	—	—	22,200
200	7.2	1,100	1,550	3,000	4,000	—	—	—	22,200
224	6.4	1,100	1,550	3,000	4,000	—	—	—	22,200
250	5.7	1,100	1,550	3,000	4,000	—	—	—	22,200
280	5.1	1,100	1,550	3,000	4,000	6,100	6,700	11,200	22,200
315	4.5	1,100	1,550	3,000	4,000	6,100	6,700	11,200	22,200
355	4.0	1,100	1,550	3,000	4,000	6,100	6,700	11,200	22,200
400	3.6	1,100	1,550	3,000	4,000	6,100	6,700	11,200	22,200
450	3.2	1,100	1,550	3,000	4,000	6,100	6,700	11,200	22,200
500	2.9	1,100	1,550	3,000	4,000	6,100	6,700	11,200	22,200
560	2.6	1,100	1,550	3,000	4,000	6,100	6,700	11,200	22,200
630	2.3	1,100	1,550	3,000	4,000	6,100	6,700	11,200	22,200
710	2.0	1,100	1,550	3,000	4,000	6,100	6,700	11,200	22,200
800	1.8	1,100	1,550	3,000	4,000	6,100	6,700	11,200	22,200
900	1.6	—	1,550	3,000	4,000	6,100	6,700	11,200	22,200
1000 (10C)	1.4	—	—	3,000	4,000	6,100	6,700	11,200	22,200
1120 (11C)	1.3	—	—	—	4,000	6,100	—	11,200	22,200

300UJ — Gear Drive LSS Overhung Load Ratings

1170 High-Speed Shaft RPM/Double Reduction (Pounds at Low-Speed Shaft)

Ratio Code	Approx L.S. Shaft RPM	Overhung Load Capacity - lbs							
		Drive Size							
		302	304	306	307	308	309	310	312
3.1	371	—	—	2,350	2,700	3,400	4,500	6,200	—
3.5	330	610	—	2,450	2,750	3,500	4,700	6,300	—
4.0	293	620	—	2,450	2,800	3,500	4,700	6,500	—
4.5	260	610	1,550	2,600	2,900	3,600	4,900	6,700	—
5.0	234	640	1,550	2,700	2,950	3,600	4,900	7,000	—
5.6	209	670	1,550	2,800	3,000	3,700	5,200	7,100	—
6.3	186	720	1,550	3,000	3,100	3,700	5,100	6,400	—
7.1	165	760	1,550	3,000	3,200	4,000	5,200	6,500	—
8.0	146	810	1,550	3,000	3,200	4,100	5,200	6,600	—
9.0	130	790	1,550	3,000	3,300	4,200	5,400	6,700	—
10.	117	820	1,550	3,000	3,400	4,300	5,400	7,000	—
11.	104	870	1,550	3,000	3,500	4,500	5,600	7,200	—
12.	93.6	920	1,550	3,000	3,600	4,600	5,800	7,400	—
14.	83.6	970	1,550	3,000	3,700	4,800	6,000	7,600	—
16.	73.1	1,050	1,550	3,000	3,800	4,900	6,100	7,900	—
18.	65.0	1,100	1,550	3,000	4,000	5,100	6,300	8,300	—
20.	58.5	1,100	1,550	3,000	4,000	5,300	6,400	8,500	—
22.	52.2	1,100	1,550	3,000	4,000	5,500	6,500	8,800	—
25.	46.8	1,100	1,550	3,000	4,000	5,700	6,700	9,100	—
28.	41.8	1,100	1,550	3,000	4,000	5,800	6,700	9,600	—
31.	37.1	1,100	1,550	3,000	4,000	6,000	6,700	9,800	—
35.	33.0	1,100	1,550	3,000	4,000	6,100	6,700	10,500	—
40.	29.3	1,100	1,550	3,000	4,000	6,100	6,700	11,000	—
45.	26.0	1,100	1,550	3,000	4,000	6,100	6,700	11,200	—
50.	23.4	1,100	1,550	3,000	4,000	6,100	6,700	11,200	—
56.	20.9	1,100	1,550	3,000	4,000	6,100	6,700	11,200	—
63.	18.6	1,100	1,550	3,000	4,000	—	6,700	—	—
71.	16.5	1,100	1,550	3,000	4,000	—	6,700	—	—
80.	14.6	1,100	1,550	3,000	—	—	—	—	—
90.	13.0	1,100	1,550	3,000	—	—	—	—	—
100	11.7	—	1,550	3,000	—	—	—	—	—

1170 High-Speed Shaft RPM/Triple Reduction (Pounds at Low-Speed Shaft)

Ratio Code	Approx L.S. Shaft RPM	Overhung Load Capacity - lbs							
		Drive Size							
		302	304	306	307	308	309	310	312
8.0	219	—	—	—	—	—	—	—	8,674
9.0	194	—	—	—	—	—	—	—	9,142
10.	175	—	—	—	—	—	—	—	9,078
11.	156	—	—	—	—	—	—	—	9,338
12.	140	—	—	—	—	—	—	—	9,374
14.	125	—	—	—	—	—	—	—	9,635
16.	109	—	—	—	—	—	—	—	9,795
18.	97.2	—	—	—	—	—	—	—	10,317
20.	87.5	—	—	—	—	—	—	—	10,802
22.	78.1	—	—	—	—	—	—	—	10,738
25.	70.0	—	—	—	—	—	—	—	11,691
28.	62.5	—	—	—	—	—	—	—	12,337
31.	55.6	—	—	—	—	—	—	—	13,047
35.	33.0	—	—	—	4,000	6,100	—	—	13,279
40.	29.3	—	—	—	4,000	6,100	6,700	11,200	14,150
45.	26.0	—	—	—	4,000	6,100	6,700	11,200	14,978
50.	23.4	—	—	—	4,000	6,100	6,700	11,200	15,878
56.	20.9	—	—	—	4,000	6,100	6,700	11,200	16,777
63.	18.6	—	—	—	4,000	6,100	6,700	11,200	17,085
71.	16.5	—	—	—	4,000	6,100	6,700	11,200	17,760
80.	14.6	—	—	—	4,000	6,100	6,700	11,200	18,434
90.	13.0	—	—	—	4,000	6,100	6,700	11,200	19,558
100	11.7	—	—	—	4,000	6,100	6,700	11,200	20,458
112	10.4	—	—	—	4,000	6,100	6,700	11,200	21,806
125	9.4	—	—	—	4,000	6,100	6,700	11,200	22,200
140	8.4	—	—	—	4,000	6,100	6,700	11,200	—
160	7.3	—	—	—	4,000	6,100	6,700	11,200	—
180	6.5	—	—	—	4,000	6,100	6,700	11,200	—
200	5.9	—	—	—	4,000	6,100	6,700	11,200	—
224	5.2	—	—	—	4,000	6,100	6,700	11,200	—
250	4.7	—	—	—	—	6,100	6,700	11,200	—
280	4.2	—	—	—	—	6,100	6,700	11,200	—
315	3.7	—	—	—	—	6,100	6,700	—	—

300UJ — Gear Drive LSS Overhung Load Ratings

1170 High-Speed Shaft RPM/Quadruple and Quintuple Reduction (Pounds at Low-Speed Shaft)

Ratio Code	Approx L.S. Shaft RPM	Overhung Load Capacity - lbs							
		Drive Size							
		302	304	306	307	308	309	310	312
100	11.7	1,100	1,550	3,000	—	—	—	—	—
112	10.4	1,100	1,550	3,000	—	—	—	—	—
125	9.4	1,100	1,550	3,000	—	—	—	—	—
140	8.4	1,100	1,550	3,000	—	—	—	—	—
160	7.3	1,100	1,550	3,000	—	—	—	—	—
180	6.5	1,100	1,550	3,000	4,000	—	—	—	—
200	5.9	1,100	1,550	3,000	4,000	—	—	—	—
224	5.2	1,100	1,550	3,000	4,000	—	—	—	—
250	4.7	1,100	1,550	3,000	4,000	—	—	—	—
280	4.2	1,100	1,550	3,000	4,000	6,100	6,700	11,200	—
315	3.7	1,100	1,550	3,000	4,000	6,100	6,700	11,200	—
355	3.3	1,100	1,550	3,000	4,000	6,100	6,700	11,200	—
400	2.9	1,100	1,550	3,000	4,000	6,100	6,700	11,200	—
450	2.6	1,100	1,550	3,000	4,000	6,100	6,700	11,200	—
500	2.3	1,100	1,550	3,000	4,000	6,100	6,700	11,200	—
560	2.1	1,100	1,550	3,000	4,000	6,100	6,700	11,200	—
630	1.9	1,100	1,550	3,000	4,000	6,100	6,700	11,200	—
710	1.6	1,100	1,550	3,000	4,000	6,100	6,700	11,200	—
800	1.5	1,100	1,550	3,000	4,000	6,100	6,700	11,200	—
900	1.3	—	1,550	3,000	4,000	6,100	6,700	11,200	—
1000 (10C)	1.2	—	—	3,000	4,000	6,100	6,700	11,200	—
1120 (11C)	1.0	—	—	—	4,000	6,100	—	11,200	—

300UJ — Gear Drive LSS Overhung Load Ratings

870 High-Speed Shaft RPM/Double Reduction (Pounds at Low-Speed Shaft)

Ratio Code	Approx L.S. Shaft RPM	Overhung Load Capacity - lbs							
		Drive Size							
		302	304	306	307	308	309	310	312
3.1	276	—	—	2,600	2,700	3,700	4,900	6,600	—
3.5	245	630	—	2,700	3,000	3,800	5,100	6,900	—
4.0	218	650	—	2,750	3,000	3,800	5,200	7,000	—
4.5	193	700	1,550	2,850	3,100	3,800	5,300	7,200	—
5.0	174	740	1,550	3,000	3,200	3,900	5,400	7,600	—
5.6	155	790	1,550	3,000	3,300	4,000	5,500	7,600	—
6.3	138	820	1,550	3,000	3,200	4,000	5,500	7,000	—
7.1	123	880	1,550	3,000	3,600	4,300	5,600	7,100	—
8.0	109	920	1,550	3,000	3,500	4,400	5,600	7,200	—
9.0	96.7	900	1,550	3,000	3,600	4,600	5,800	7,300	—
10.	87.0	940	1,550	3,000	3,700	4,600	6,000	7,400	—
11.	77.7	1,000	1,550	3,000	3,800	4,800	6,100	7,800	—
12.	69.6	1,050	1,550	3,000	3,900	5,000	6,200	8,000	—
14.	62.1	1,100	1,550	3,000	4,000	5,100	6,400	8,200	—
16.	54.4	1,100	1,550	3,000	4,000	5,400	6,600	8,500	—
18.	48.3	1,100	1,550	3,000	4,000	5,600	6,700	9,000	—
20.	43.5	1,100	1,550	3,000	4,000	5,700	6,700	9,200	—
22.	38.8	1,100	1,550	3,000	4,000	6,000	6,700	9,700	—
25.	34.8	1,100	1,550	3,000	4,000	6,100	6,700	10,000	—
28.	31.1	1,100	1,550	3,000	4,000	6,100	6,700	10,500	—
31.	27.6	1,100	1,550	3,000	4,000	6,100	6,700	11,000	—
35.	24.5	1,100	1,550	3,000	4,000	6,100	6,700	11,200	—
40.	21.8	1,100	1,550	3,000	4,000	6,100	6,700	11,200	—
45.	19.3	1,100	1,550	3,000	4,000	6,100	6,700	11,200	—
50.	17.4	1,100	1,550	3,000	4,000	6,100	6,700	11,200	—
56.	15.5	1,100	1,550	3,000	4,000	6,100	6,700	11,200	—
63.	13.8	1,100	1,550	3,000	4,000	—	6,700	—	—
71.	12.3	1,100	1,550	3,000	4,000	—	6,700	—	—
80.	10.9	1,100	1,550	3,000	—	—	—	—	—
90.	9.7	1,100	1,550	3,000	—	—	—	—	—
100	8.7	—	1,550	3,000	—	—	—	—	—

870 High-Speed Shaft RPM/Triple Reduction (Pounds at Low-Speed Shaft)

Ratio Code	Approx L.S. Shaft RPM	Overhung Load Capacity - lbs							
		Drive Size							
		302	304	306	307	308	309	310	312
8.0	219	—	—	—	—	—	—	—	9,274
9.0	194	—	—	—	—	—	—	—	9,742
10.	175	—	—	—	—	—	—	—	9,478
11.	156	—	—	—	—	—	—	—	9,938
12.	140	—	—	—	—	—	—	—	9,974
14.	125	—	—	—	—	—	—	—	10,235
16.	109	—	—	—	—	—	—	—	10,395
18.	97.2	—	—	—	—	—	—	—	11,017
20.	87.5	—	—	—	—	—	—	—	11,502
22.	78.1	—	—	—	—	—	—	—	11,638
25.	70.0	—	—	—	—	—	—	—	12,591
28.	62.5	—	—	—	—	—	—	—	13,237
31.	55.6	—	—	—	—	—	—	—	14,247
35.	24.5	—	—	—	4,000	6,100	—	—	13,979
40.	21.8	—	—	—	4,000	6,100	6,700	11,200	14,350
45.	19.3	—	—	—	4,000	6,100	6,700	11,200	14,978
50.	17.4	—	—	—	4,000	6,100	6,700	11,200	15,878
56.	15.5	—	—	—	4,000	6,100	6,700	11,200	16,777
63.	13.8	—	—	—	4,000	6,100	6,700	11,200	17,085
71.	12.3	—	—	—	4,000	6,100	6,700	11,200	17,760
80.	10.9	—	—	—	4,000	6,100	6,700	11,200	18,434
90.	9.7	—	—	—	4,000	6,100	6,700	11,200	19,558
100	8.7	—	—	—	4,000	6,100	6,700	11,200	20,458
112	7.8	—	—	—	4,000	6,100	6,700	11,200	21,806
125	7.0	—	—	—	4,000	6,100	6,700	11,200	22,200
140	6.2	—	—	—	4,000	6,100	6,700	11,200	—
160	5.4	—	—	—	4,000	6,100	6,700	11,200	—
180	4.8	—	—	—	4,000	6,100	6,700	11,200	—
200	4.4	—	—	—	4,000	6,100	6,700	11,200	—
224	3.9	—	—	—	4,000	6,100	6,700	11,200	—
250	3.5	—	—	—	—	6,100	6,700	11,200	—
280	3.1	—	—	—	—	6,100	6,700	11,200	—
315	2.8	—	—	—	—	6,100	6,700	—	—

300UJ — Gear Drive LSS Overhung Load Ratings

870 High-Speed Shaft RPM/Quadruple and Quintuple Reduction (Pounds at Low-Speed Shaft)

Ratio Code	Approx L.S. Shaft RPM	Overhung Load Capacity - lbs							
		Drive Size							
		302	304	306	307	308	309	310	312
100	8.7	1,100	1,550	3,000	—	—	—	—	—
112	7.8	1,100	1,550	3,000	—	—	—	—	—
125	7.0	1,100	1,550	3,000	—	—	—	—	—
140	6.2	1,100	1,550	3,000	—	—	—	—	—
160	5.4	1,100	1,550	3,000	—	—	—	—	—
180	4.8	1,100	1,550	3,000	4,000	—	—	—	—
200	4.4	1,100	1,550	3,000	4,000	—	—	—	—
224	3.9	1,100	1,550	3,000	4,000	—	—	—	—
250	3.5	1,100	1,550	3,000	4,000	—	—	—	—
280	3.1	1,100	1,550	3,000	4,000	6,100	6,700	11,200	—
315	2.8	1,100	1,550	3,000	4,000	6,100	6,700	11,200	—
355	2.5	1,100	1,550	3,000	4,000	6,100	6,700	11,200	—
400	2.2	1,100	1,550	3,000	4,000	6,100	6,700	11,200	—
450	1.9	1,100	1,550	3,000	4,000	6,100	6,700	11,200	—
500	1.7	1,100	1,550	3,000	4,000	6,100	6,700	11,200	—
560	1.6	1,100	1,550	3,000	4,000	6,100	6,700	11,200	—
630	1.4	1,100	1,550	3,000	4,000	6,100	6,700	11,200	—
710	1.2	1,100	1,550	3,000	4,000	6,100	6,700	11,200	—
800	1.1	1,100	1,550	3,000	4,000	6,100	6,700	11,200	—
900	1.0	—	1,550	3,000	4,000	6,100	6,700	11,200	—
1000 (10C)	0.9	—	—	3,000	4,000	6,100	6,700	11,200	—
1120 (11C)	0.8	—	—	—	4,000	6,100	—	11,200	—

300UJ — Gear Drive Horsepower and Torque Ratings

1750 High-Speed Shaft RPM/Double Reduction (Torque is in lb-in at Low-Speed Shaft)

Ratio Code	Approx L.S. Shaft RPM	Horsepower								Torque							
		Drive Size								Drive Size							
		302	304	306	307	308	309	310	312	302	304	306	307	308	309	310	312
3.1	556	—	—	23.5	34.4	61.0	86.6	116	—	—	—	2513	4080	7018	9735	13098	—
3.5	493	6.23	—	23.4	34.4	61.0	85.9	117	—	779	—	2912	4514	7744	10709	14868	—
4.0	438	6.25	—	23.4	33.4	60.9	86.2	117	—	894	—	3266	5045	8912	12833	16815	—
4.5	389	6.46	11.6	23.0	31.5	58.7	85.9	117	—	991	1947	3673	5399	9691	13718	19116	—
5.0	350	6.27	10.1	21.0	29.8	56.3	86.3	117	—	1106	1947	3673	5753	10266	15930	20798	—
5.6	313	6.24	9.47	18.2	27.6	53.5	81.4	113	—	1274	1947	3673	6107	11063	16815	23010	—
6.3	278	6.24	8.23	16.4	26.5	54.2	87.0	153	—	1372	1947	3673	6461	12567	19913	34515	—
7.1	246	6.15	7.11	14.8	25.0	51.9	83.6	145	—	1460	1947	3673	6726	13275	21240	37170	—
8.0	219	5.25	6.60	22.5	28.1	48.4	77.5	137	—	1460	1947	6549	7965	14249	23453	39825	—
9.0	194	6.25	11.2	20.9	26.4	45.2	74.9	128	—	1903	3806	7080	8408	15045	24338	42038	—
10.	175	5.83	9.96	19.9	24.2	43.4	69.5	123	—	2036	3850	7523	8850	15930	26108	44250	—
11.	156	5.44	9.40	17.3	22.6	39.5	65.3	111	—	2036	3894	7523	9381	16461	27435	45578	—
12.	140	4.73	8.17	15.8	20.8	36.2	63.4	106	—	2036	3894	7523	9735	16992	28763	47348	—
14.	125	4.09	7.07	13.7	18.8	33.6	58.9	95.6	—	2036	3894	7523	10089	17523	30090	49118	—
16.	109	3.51	6.56	12.4	17.5	30.6	55.0	89.8	—	2036	3894	7523	10355	18143	31860	50888	—
18.	97.2	3.00	6.07	11.1	16.4	29.2	52.6	82.0	—	2036	3894	7523	10709	18674	33188	52215	—
20.	87.5	2.75	5.18	10.4	15.1	27.1	48.3	76.1	—	2036	3894	7523	11063	19249	34958	53985	—
22.	78.1	2.52	4.76	8.93	14.1	24.6	44.3	70.1	—	2036	3894	7523	11505	20090	37170	55755	—
25.	70.0	2.30	3.98	8.29	12.8	19.2	41.8	64.6	—	2036	3894	7523	11948	17700	38940	57968	—
28.	62.5	2.09	3.61	7.30	11.3	19.0	40.0	59.6	—	2036	3894	7523	12390	19913	39825	60180	—
31.	55.6	1.89	3.27	6.44	10.9	19.4	37.2	53.6	—	2036	3894	7523	12833	22302	41153	62393	—
35.	49.3	1.51	2.93	5.91	10.2	17.8	34.2	50.4	—	2036	3894	7523	13364	23453	42923	64163	—
40.	43.8	1.36	2.61	5.17	9.34	17.0	32.3	47.4	—	2036	3894	7523	13895	24338	44250	65490	—
45.	38.9	1.21	2.34	4.62	8.89	15.0	29.0	41.8	—	2036	3894	7523	14337	25400	45578	68145	—
50.	35.0	1.15	2.10	3.86	8.08	13.6	25.0	39.3	—	2036	3894	7523	15045	25665	42923	70800	—
56.	31.3	1.04	1.80	3.47	7.36	11.4	21.2	35.3	—	2036	3894	7523	15045	23895	42923	70800	—
63.	27.8	0.94	1.62	3.14	6.17	—	19.3	—	—	2036	3894	7523	15045	—	42923	—	—
71.	24.6	0.75	1.30	2.82	5.34	—	16.1	—	—	2036	3230	7523	14603	—	39825	—	—
80.	21.9	0.68	1.07	2.68	—	—	—	—	—	2036	3186	7523	—	—	—	—	—
90.	19.4	0.61	0.89	2.44	—	—	—	—	—	2036	2965	7523	—	—	—	—	—
100	17.5	—	0.74	1.85	—	—	—	—	—	—	2744	7080	—	—	—	—	—

1750 High-Speed Shaft RPM/Triple Reduction (Torque is in lb-in at Low-Speed Shaft)

Ratio Code	Approx L.S. Shaft RPM	Horsepower								Torque							
		Drive Size								Drive Size							
		302	304	306	307	308	309	310	312	302	304	306	307	308	309	310	312
8.0	219	—	—	—	—	—	—	—	140	—	—	—	—	—	—	—	38409
9.0	194	—	—	—	—	—	—	—	140	—	—	—	—	—	—	—	43454
10.	175	—	—	—	—	—	—	—	140	—	—	—	—	—	—	—	49206
11.	156	—	—	—	—	—	—	—	140	—	—	—	—	—	—	—	55844
12.	140	—	—	—	—	—	—	—	140	—	—	—	—	—	—	—	60844
14.	125	—	—	—	—	—	—	—	205	—	—	—	—	—	—	—	103546
16.	109	—	—	—	—	—	—	—	192	—	—	—	—	—	—	—	109741
18.	97.2	—	—	—	—	—	—	—	179	—	—	—	—	—	—	—	115936
20.	87.5	—	—	—	—	—	—	—	166	—	—	—	—	—	—	—	122131
22.	78.1	—	—	—	—	—	—	—	159	—	—	—	—	—	—	—	127441
25.	70.0	—	—	—	—	—	—	—	145	—	—	—	—	—	—	—	132751
28.	62.5	—	—	—	—	—	—	—	133	—	—	—	—	—	—	—	132751
31.	55.6	—	—	—	—	—	—	—	115	—	—	—	—	—	—	—	132751
35.	49.3	—	—	—	9.26	16.0	—	—	104	—	—	—	11948	19470	—	—	132751
40.	43.8	—	—	—	8.31	14.9	28.3	43.9	93.3	—	—	—	12390	20355	38940	62393	132751
45.	38.9	—	—	—	7.84	13.5	26.7	40.5	83.8	—	—	—	12921	21240	41153	64605	132751
50.	35.0	—	—	—	7.26	12.4	24.4	36.7	74.8	—	—	—	13275	22125	43365	67260	132751
56.	31.3	—	—	—	6.96	11.5	23.3	33.6	66.2	—	—	—	13629	23010	46905	69915	132751
63.	27.8	—	—	—	6.26	10.4	21.1	30.3	58.8	—	—	—	14337	23895	47790	70800	132751
71.	24.6	—	—	—	5.95	9.81	18.7	26.4	51.0	—	—	—	14691	24780	48675	70800	132751
80.	21.9	—	—	—	5.37	9.23	17.0	23.9	46.7	—	—	—	15045	25665	48675	70800	132751
90.	19.4	—	—	—	4.74	8.19	15.4	21.7	43.0	—	—	—	15045	25665	48675	70800	132751
100	17.5	—	—	—	4.35	7.39	13.7	19.3	36.4	—	—	—	15045	25665	48675	70800	132751
112	15.6	—	—	—	3.76	6.45	12.3	17.4	33.0	—	—	—	15045	25665	48675	70800	132751
125	14.0	—	—	—	3.40	5.49	10.8	15.2	29.7	—	—	—	15045	25665	48675	70800	132751
140	12.5	—	—	—	2.84	5.13	9.21	12.9	—	—	—	—	15045	25665	48675	70800	—
160	10.9	—	—	—	2.55	4.59	8.60	12.1	—	—	—	—	15045	25665	48675	70800	—
180	9.70	—	—	—	2.31	4.03	7.70	10.8	—	—	—	—	15045	25665	48675	70800	—
200	8.80	—	—	—	2.08	3.71	6.75	9.50	—	—	—	—	15045	25665	48675	70800	—
224	7.80	—	—	—	—	3.22	6.23	8.76	—	—	—	—	—	25665	48675	70800	—
250	7.00	—	—	—	—	2.93	5.39	7.59	—	—	—	—	—	25665	48675	70800	—
280	6.30	—	—	—	—	2.46	4.91	6.91	—	—	—	—	—	25665	48675	70800	—
315	5.60	—	—	—	—	2.19	—	—	—	—	—	—	—	25665	—	—	—

300UJ — Gear Drive Horsepower and Torque Ratings

1750 High-Speed Shaft RPM/Quadruple and Quintuple Reduction (Torque is in lb-in at Low-Speed Shaft)

Ratio Code	Approx L.S. Shaft RPM	Horsepower Drive Size								Torque Drive Size							
		302	304	306	307	308	309	310	312	302	304	306	307	308	309	310	312
100	17.5	0.58	1.06	2.09	—	—	—	—	—	2036	3894	7523	—	—	—	—	—
112	15.6	0.50	1.00	1.95	—	—	—	—	—	2036	3894	7523	—	—	—	—	—
125	14.0	0.44	0.86	1.70	—	—	—	—	—	2036	3894	7523	—	—	—	—	—
140	12.5	0.41	0.75	1.47	—	—	—	—	—	2036	3894	7523	—	—	—	—	—
160	10.9	0.35	0.70	1.36	—	—	—	—	—	2036	3894	7523	—	—	—	—	—
180	9.7	0.32	0.60	1.14	2.29	—	—	—	21.1	2036	3894	7523	15045	—	—	—	132751
200	8.8	0.28	0.55	1.08	1.98	—	—	—	18.2	2036	3894	7523	15045	—	—	—	132751
224	7.8	0.25	0.48	0.95	1.84	—	—	—	16.2	2036	3894	7523	15045	—	—	—	132751
250	7.0	0.22	0.44	0.83	1.70	—	—	—	14.2	2036	3894	7523	15045	—	—	—	132751
280	6.3	0.20	0.39	0.75	1.45	2.47	4.96	7.04	12.9	2036	3894	7523	15045	25665	48675	70800	132751
315	5.6	0.17	0.35	0.68	1.34	2.27	4.24	6.57	11.2	2036	3894	7523	15045	25665	48675	70800	132751
355	4.9	0.16	0.30	0.61	1.12	1.89	3.94	5.62	10.1	2036	3894	7523	15045	25665	48675	70800	132751
400	4.4	0.14	0.27	0.54	1.01	1.72	3.47	5.22	9.14	2036	3894	7523	15045	25665	48675	70800	132751
450	3.9	0.12	0.24	0.47	0.92	1.55	3.06	4.59	8.53	2036	3894	7523	15045	25665	48675	70800	132751
500	3.5	0.11	0.22	0.43	0.82	1.40	2.81	4.06	7.29	2036	3894	7523	15045	25665	48675	70800	132751
560	3.1	0.10	0.19	0.37	0.73	1.24	2.43	3.72	6.77	2036	3894	7523	15045	25665	48675	70800	132751
630	2.8	0.09	0.17	0.34	0.66	1.12	2.20	3.21	5.96	2036	3894	7523	15045	25665	48675	70800	132751
710	2.5	0.08	0.15	0.28	0.59	1.00	1.84	2.91	5.27	2036	3894	7523	15045	25665	48675	70800	132751
800	2.2	0.07	0.14	0.26	0.51	0.86	1.65	2.43	4.83	2036	3894	7523	15045	25665	48675	70800	132751
900	1.9	—	0.12	0.22	0.45	0.77	1.49	2.18	4.17	—	3894	7523	15045	25665	48675	70800	132751
1000 (10C)	1.8	—	—	0.21	0.44	0.75	1.34	1.97	3.86	—	—	7523	15045	25665	48675	70800	132751
1120 (11C)	1.6	—	—	—	0.37	0.62	—	1.78	3.40	—	—	—	15045	25665	—	70800	132751

300UJ — Gear Drive Horsepower and Torque Ratings

1430 High-Speed Shaft RPM/Double Reduction (Torque is in lb-in at Low-Speed Shaft)

Ratio Code	Approx L.S. Shaft RPM	Horsepower								Torque							
		Drive Size								Drive Size							
		302	304	306	307	308	309	310	312	302	304	306	307	308	309	310	312
3.1	454	—	—	19.2	28.1	49.9	70.8	95.5	—	—	—	2513	4080	7018	9735	13098	—
3.5	403	5.09	—	19.1	28.1	49.9	70.2	95.8	—	779	—	2912	4514	7744	10709	14868	—
4.0	358	5.11	—	19.2	27.3	49.8	70.5	95.6	—	894	—	3266	5045	8912	12833	16815	—
4.5	318	5.28	9.50	18.8	25.7	48.0	70.2	95.9	—	991	1947	3673	5399	9691	13718	19116	—
5.0	286	5.12	8.29	17.1	24.4	46.0	70.5	95.7	—	1106	1947	3673	5753	10266	15930	20798	—
5.6	255	5.10	7.74	14.8	22.6	43.7	66.5	92.9	—	1274	1947	3673	6107	11063	16815	23010	—
6.3	227	5.10	6.72	13.4	21.6	44.3	71.1	125	—	1372	1947	3673	6461	12567	19913	34515	—
7.1	201	5.03	5.81	12.1	20.4	42.4	68.3	119	—	1460	1947	3673	6726	13275	21240	37170	—
8.0	179	4.29	5.39	18.4	22.9	39.5	63.3	112	—	1460	1947	6549	7965	14249	23453	39825	—
9.0	159	5.10	9.22	17.1	21.6	36.9	61.2	104	—	1903	3806	7080	8408	15045	24338	42038	—
10.	143	4.77	8.14	16.2	19.7	35.4	56.7	101	—	2036	3850	7523	8850	15930	26108	44250	—
11.	128	4.45	7.68	14.2	18.4	32.3	53.3	91.4	—	2036	3894	7523	9381	16461	27435	45578	—
12.	114	3.86	6.68	12.9	17.0	29.6	51.8	86.7	—	2036	3894	7523	9735	16992	28763	47348	—
14.	102	3.34	5.77	11.2	15.4	27.5	48.1	78.1	—	2036	3894	7523	10089	17523	30090	49118	—
16.	89.4	2.87	5.36	10.1	14.3	25.0	45.0	73.4	—	2036	3894	7523	10355	18143	31860	50888	—
18.	79.4	2.45	4.96	9.14	13.4	23.8	43.0	67.0	—	2036	3894	7523	10709	18674	33188	52215	—
20.	71.5	2.25	4.23	8.53	12.3	22.1	39.5	62.2	—	2036	3894	7523	11063	19249	34958	53985	—
22.	63.8	2.06	3.89	7.29	11.5	20.1	36.2	57.3	—	2036	3894	7523	11505	20090	37170	55755	—
25.	57.2	1.88	3.25	6.77	10.5	15.7	34.1	52.8	—	2036	3894	7523	11948	17700	38940	57968	—
28.	51.1	1.71	2.95	5.96	9.28	15.5	32.7	48.7	—	2036	3894	7523	12390	19913	39825	60180	—
31.	45.4	1.54	2.67	5.27	8.98	15.8	30.4	43.8	—	2036	3894	7523	12833	22302	41153	62393	—
35.	40.3	1.23	2.40	4.83	8.37	14.5	27.9	41.2	—	2036	3894	7523	13364	23453	42923	64163	—
40.	35.8	1.11	2.13	4.17	7.63	13.9	26.4	38.7	—	2036	3894	7523	13364	24338	44250	65490	—
45.	31.8	0.99	1.92	3.78	7.26	12.3	23.7	34.1	—	2036	3894	7523	13364	25400	45578	68145	—
50.	28.6	0.94	1.71	3.16	6.60	11.1	20.4	32.1	—	2036	3894	7523	13364	25665	42923	70800	—
56.	25.5	0.85	1.47	2.84	6.01	9.34	17.3	28.9	—	2036	3894	7523	13364	23895	42923	70800	—
63.	22.7	0.77	1.32	2.56	5.04	—	15.7	—	—	2036	3894	7523	13364	—	42923	—	—
71.	20.1	0.62	1.06	2.31	4.36	—	13.1	—	—	2036	3230	7523	13364	—	39825	—	—
80.	17.9	0.55	0.87	2.19	—	—	—	—	—	2036	3186	7523	—	—	—	—	—
90.	15.9	0.49	0.73	1.99	—	—	—	—	—	2036	2965	7523	—	—	—	—	—
100	14.3	—	0.60	1.51	—	—	—	—	—	—	2744	7080	—	—	—	—	—

1430 High-Speed Shaft RPM/Triple Reduction (Torque is in lb-in at Low-Speed Shaft)

Ratio Code	Approx L.S. Shaft RPM	Horsepower								Torque							
		Drive Size								Drive Size							
		302	304	306	307	308	309	310	312	302	304	306	307	308	309	310	312
8.0	219	—	—	—	—	—	—	—	115	—	—	—	—	—	—	—	38409
9.0	194	—	—	—	—	—	—	—	115	—	—	—	—	—	—	—	43454
10.	175	—	—	—	—	—	—	—	115	—	—	—	—	—	—	—	49206
11.	156	—	—	—	—	—	—	—	115	—	—	—	—	—	—	—	55844
12.	140	—	—	—	—	—	—	—	115	—	—	—	—	—	—	—	60844
14.	125	—	—	—	—	—	—	—	168	—	—	—	—	—	—	—	103546
16.	109	—	—	—	—	—	—	—	157	—	—	—	—	—	—	—	109741
18.	97.2	—	—	—	—	—	—	—	146	—	—	—	—	—	—	—	115936
20.	87.5	—	—	—	—	—	—	—	136	—	—	—	—	—	—	—	122131
22.	78.1	—	—	—	—	—	—	—	130	—	—	—	—	—	—	—	127441
25.	70.0	—	—	—	—	—	—	—	119	—	—	—	—	—	—	—	132751
28.	62.5	—	—	—	—	—	—	—	108	—	—	—	—	—	—	—	132751
31.	55.6	—	—	—	—	—	—	—	94.5	—	—	—	—	—	—	—	132751
35.	40.3	—	—	—	7.57	13.1	—	—	85.7	—	—	—	13364	19470	—	—	132751
40.	35.8	—	—	—	6.79	12.2	23.1	35.9	76.2	—	—	—	13364	20355	38940	62393	132751
45.	31.8	—	—	—	6.41	11.0	21.8	33.1	68.5	—	—	—	13364	21240	41153	64605	132751
50.	28.6	—	—	—	5.93	10.1	20.0	29.9	61.1	—	—	—	13364	22125	43365	67260	132751
56.	25.5	—	—	—	5.68	9.42	19.0	27.5	54.1	—	—	—	13364	23010	46905	69915	132751
63.	22.7	—	—	—	5.11	8.53	17.2	24.7	48.1	—	—	—	13364	23895	47790	70800	132751
71.	20.1	—	—	—	4.87	8.01	15.3	21.5	41.7	—	—	—	13364	24780	48675	70800	132751
80.	17.9	—	—	—	4.39	7.54	13.9	19.5	38.1	—	—	—	13364	25665	48675	70800	132751
90.	15.9	—	—	—	3.87	6.69	12.6	17.7	35.2	—	—	—	13364	25665	48675	70800	132751
100	14.3	—	—	—	3.55	6.04	11.2	15.7	29.8	—	—	—	13364	25665	48675	70800	132751
112	12.8	—	—	—	3.07	5.27	10.1	14.2	27.0	—	—	—	13364	25665	48675	70800	132751
125	11.4	—	—	—	2.78	4.49	8.84	12.4	24.2	—	—	—	13364	25665	48675	70800	132751
140	10.2	—	—	—	2.32	4.19	7.52	10.5	—	—	—	—	13364	25665	48675	70800	-
160	8.9	—	—	—	2.09	3.75	7.03	9.89	—	—	—	—	13364	25665	48675	70800	-
180	7.9	—	—	—	1.89	3.29	6.29	8.85	—	—	—	—	13364	25665	48675	70800	-
200	7.2	—	—	—	1.70	3.03	5.52	7.76	—	—	—	—	13364	25665	48675	70800	-
224	6.4	—	—	—	—	2.63	5.09	7.16	—	—	—	—	—	25665	48675	70800	-
250	5.7	—	—	—	—	2.39	4.41	6.20	—	—	—	—	—	25665	48675	70800	-
280	5.1	—	—	—	—	2.01	4.01	5.65	—	—	—	—	—	25665	48675	70800	-
315	4.5	—	—	—	—	1.79	—	—	—	—	—	—	—	25665	—	—	-

300UJ — Gear Drive Horsepower and Torque Ratings

1430 High-Speed Shaft RPM/Quadruple and Quintuple Reduction (Torque is in lb-in at Low-Speed Shaft)

Ratio Code	Approx L.S. Shaft RPM	Horsepower									Torque								
		Drive Size									Drive Size								
		Quadruple					Quintuple				Quadruple					Quintuple			
		302	304	306	307	308	309	310	312	302	304	306	307	308	309	310	312		
100	14.3	0.48	0.87	1.71	—	—	—	—	—	2036	3894	7523	—	—	—	—	—		
112	12.8	0.41	0.82	1.60	—	—	—	—	—	2036	3894	7523	—	—	—	—	—		
125	11.4	0.36	0.71	1.39	—	—	—	—	—	2036	3894	7523	—	—	—	—	—		
140	10.2	0.33	0.61	1.20	—	—	—	—	—	2036	3894	7523	—	—	—	—	—		
160	8.9	0.28	0.57	1.11	—	—	—	—	—	2036	3894	7523	—	—	—	—	—		
180	7.9	0.26	0.49	0.93	1.87	—	—	—	17.2	2036	3894	7523	—	—	—	—	132751		
200	7.2	0.23	0.45	0.88	1.62	—	—	—	14.8	2036	3894	7523	—	—	—	—	132751		
224	6.4	0.21	0.39	0.78	1.50	—	—	—	13.2	2036	3894	7523	—	—	—	—	132751		
250	5.7	0.18	0.36	0.67	1.39	—	—	—	11.6	2036	3894	7523	—	—	—	—	132751		
280	5.1	0.17	0.32	0.61	1.19	2.01	4.05	5.75	10.5	2036	3894	7523	15045	25665	48675	70800	132751		
315	4.5	0.14	0.29	0.55	1.09	1.85	3.47	5.37	9.16	2036	3894	7523	15045	25665	48675	70800	132751		
355	4.0	0.13	0.25	0.50	0.91	1.55	3.22	4.59	8.29	2036	3894	7523	15045	25665	48675	70800	132751		
400	3.6	0.11	0.22	0.44	0.83	1.41	2.83	4.26	7.46	2036	3894	7523	15045	25665	48675	70800	132751		
450	3.2	0.10	0.20	0.39	0.75	1.27	2.50	3.75	6.97	2036	3894	7523	15045	25665	48675	70800	132751		
500	2.9	0.09	0.18	0.35	0.67	1.14	2.30	3.31	5.96	2036	3894	7523	15045	25665	48675	70800	132751		
560	2.6	0.08	0.16	0.31	0.60	1.02	1.98	3.04	5.53	2036	3894	7523	15045	25665	48675	70800	132751		
630	2.3	0.08	0.14	0.27	0.54	0.91	1.80	2.63	4.87	2036	3894	7523	15045	25665	48675	70800	132751		
710	2.0	0.07	0.12	0.23	0.48	0.82	1.50	2.38	4.30	2036	3894	7523	15045	25665	48675	70800	132751		
800	1.8	0.06	0.12	0.21	0.41	0.70	1.35	1.99	3.95	2036	3894	7523	15045	25665	48675	70800	132751		
900	1.6	—	0.10	0.18	0.37	0.63	1.22	1.78	3.41	—	3894	7523	15045	25665	48675	70800	132751		
1000 (10C)	1.4	—	—	0.17	0.36	0.61	1.10	1.61	3.15	—	—	7523	15045	25665	48675	70800	132751		
1120 (11C)	1.3	—	—	—	0.30	0.51	—	1.45	2.78	—	—	—	15045	25665	—	70800	132751		

300UJ — Gear Drive Horsepower and Torque Ratings

1170 High-Speed Shaft RPM/Double Reduction (Torque is in lb-in at Low-Speed Shaft)

Ratio Code	Approx L.S. Shaft RPM	Horsepower								Torque							
		Drive Size								Drive Size							
		302	304	306	307	308	309	310	312	302	304	306	307	308	309	310	312
3.1	371	—	—	20.1	20.1	46.6	81.0	117	—	—	—	3230	3575	8009	13629	19647	—
3.5	330	6.25	—	17.3	26.4	46.6	78.3	112	—	1168	—	3230	5177	8850	14603	21240	—
4.0	293	6.29	—	17.4	25.4	46.5	72.4	105	—	1345	—	3629	5753	10178	16107	22745	—
4.5	260	6.36	7.77	15.4	24.0	44.8	71.9	99.5	—	1460	1947	3673	6151	11063	17169	24249	—
5.0	234	5.53	6.78	14.0	22.7	43.0	65.7	89.2	—	1460	1947	3673	6549	11726	18143	23709	—
5.6	209	4.78	6.33	12.1	21.1	40.7	62.2	86.5	—	1460	1947	3673	6992	12611	19205	26196	—
6.3	186	4.44	5.50	11.0	20.2	41.3	66.4	116	—	1460	1947	3673	7390	14337	22745	39383	—
7.1	165	4.11	4.76	9.92	19.1	39.5	63.8	111	—	1460	1947	3673	7700	15134	24249	42392	—
8.0	146	3.51	4.41	15.0	21.5	36.9	59.0	105	—	1460	1947	6549	9116	16240	26727	45401	—
9.0	130	4.47	7.55	14.0	20.2	34.5	57.1	97.7	—	2036	3806	7080	9602	17169	27789	47923	—
10.	117	3.90	6.66	13.3	18.4	33.0	53.0	94.5	—	2036	3850	7523	10089	18143	29825	50445	—
11.	104	3.64	6.29	11.6	17.2	30.1	49.8	85.2	—	2036	3894	7523	10709	18762	31329	51950	—
12.	93.6	3.16	5.46	10.6	15.9	27.6	48.2	80.9	—	2036	3894	7523	11151	19382	32745	53985	—
14.	83.6	2.73	4.72	9.17	14.3	25.7	44.9	72.9	—	2036	3894	7523	11505	20001	34338	56021	—
16.	73.1	2.35	4.38	8.30	13.3	23.3	41.9	68.4	—	2036	3894	7523	11815	20709	36285	58012	—
18.	65.0	2.00	4.06	7.48	12.5	22.2	40.1	62.5	—	2036	3894	7523	12213	21284	37878	59561	—
20.	58.5	1.84	3.46	6.98	11.5	20.7	36.8	57.9	—	2036	3894	7523	12611	21948	39825	61508	—
22.	52.2	1.69	3.18	5.97	10.8	18.7	33.8	53.4	—	2036	3894	7523	13098	22922	42392	63543	—
25.	46.8	1.54	2.66	5.54	9.81	17.3	31.9	49.2	—	2036	3894	7523	13629	23895	44427	66110	—
28.	41.8	1.40	2.42	4.88	8.68	15.8	30.5	44.0	—	2036	3894	7523	14160	24780	45401	66552	—
31.	37.1	1.26	2.18	4.31	8.36	14.8	28.3	40.6	—	2036	3894	7523	14603	25444	46905	70800	—
35.	33.0	1.01	1.96	3.95	7.71	13.0	25.9	37.2	—	2036	3894	7523	15045	25665	48675	70800	—
40.	29.3	0.91	1.74	3.41	6.76	12.0	23.7	34.3	—	2036	3894	7523	15045	25665	48675	70800	—
45.	26.0	0.81	1.57	3.09	6.24	10.1	20.7	29.0	—	2036	3894	7523	15045	25665	48675	70800	—
50.	23.4	0.77	1.40	2.58	5.40	9.13	19.0	26.3	—	2036	3894	7523	15045	25665	48675	70800	—
56.	20.9	0.70	1.21	2.32	4.92	7.64	16.1	23.6	—	2036	3894	7523	15045	23895	48675	70800	—
63.	18.6	0.63	1.08	2.10	4.12	—	14.6	—	—	2036	3894	7523	15045	—	48675	—	—
71.	16.5	0.50	0.87	1.89	3.57	—	12.3	—	—	2036	3230	7523	14603	—	45401	—	—
80.	14.6	0.45	0.71	1.79	—	—	—	—	—	2036	3186	7523	—	—	—	—	—
90.	13.0	0.40	0.60	1.63	—	—	—	—	—	2036	2965	7523	—	—	—	—	—
100	11.7	—	0.49	1.24	—	—	—	—	—	—	2744	7080	—	—	—	—	—

1170 High-Speed Shaft RPM/Triple Reduction (Torque is in lb-in at Low-Speed Shaft)

Ratio Code	Approx L.S. Shaft RPM	Horsepower								Torque							
		Drive Size								Drive Size							
		302	304	306	307	308	309	310	312	302	304	306	307	308	309	310	312
8.0	219	—	—	—	—	—	—	—	94.1	—	—	—	—	—	—	—	38409
9.0	194	—	—	—	—	—	—	—	94.1	—	—	—	—	—	—	—	43454
10.	175	—	—	—	—	—	—	—	94.1	—	—	—	—	—	—	—	49206
11.	156	—	—	—	—	—	—	—	94.1	—	—	—	—	—	—	—	55844
12.	140	—	—	—	—	—	—	—	94.1	—	—	—	—	—	—	—	60844
14.	125	—	—	—	—	—	—	—	137	—	—	—	—	—	—	—	103546
16.	109	—	—	—	—	—	—	—	128	—	—	—	—	—	—	—	109741
18.	97.2	—	—	—	—	—	—	—	120	—	—	—	—	—	—	—	115936
20.	87.5	—	—	—	—	—	—	—	111	—	—	—	—	—	—	—	122131
22.	78.1	—	—	—	—	—	—	—	106	—	—	—	—	—	—	—	127441
25.	70.0	—	—	—	—	—	—	—	97.5	—	—	—	—	—	—	—	132751
28.	62.5	—	—	—	—	—	—	—	89.1	—	—	—	—	—	—	—	132751
31.	55.6	—	—	—	—	—	—	—	77.3	—	—	—	—	—	—	—	132751
35.	33.0	—	—	—	7.80	12.1	—	—	70.1	—	—	—	15045	22125	—	—	132751
40.	29.3	—	—	—	6.75	11.3	21.6	33.3	62.4	—	—	—	15045	23187	44392	70800	132751
45.	26.0	—	—	—	6.10	10.3	20.3	29.7	56.0	—	—	—	15045	24249	46914	70800	132751
50.	23.4	—	—	—	5.50	9.50	18.3	25.8	50.0	—	—	—	15045	25223	48675	70800	132751
56.	20.9	—	—	—	5.13	8.59	16.2	22.7	44.3	—	—	—	15045	25665	48675	70800	132751
63.	18.6	—	—	—	4.39	7.49	14.4	20.2	39.3	—	—	—	15045	25665	48675	70800	132751
71.	16.5	—	—	—	4.08	6.79	12.5	17.6	34.1	—	—	—	15045	25665	48675	70800	132751
80.	14.6	—	—	—	3.59	6.17	11.3	16.0	31.2	—	—	—	15045	25665	48675	70800	132751
90.	13.0	—	—	—	3.17	5.48	10.3	14.5	28.8	—	—	—	15045	25665	48675	70800	132751
100	11.7	—	—	—	2.91	4.94	9.18	12.9	24.4	—	—	—	15045	25665	48675	70800	132751
112	10.4	—	—	—	2.51	4.31	8.27	11.6	22.1	—	—	—	15045	25665	48675	70800	132751
125	9.4	—	—	—	2.27	3.67	7.23	10.1	19.8	—	—	—	15045	25665	48675	70800	132751
140	8.4	—	—	—	1.90	3.43	6.16	8.66	—	—	—	—	15045	25665	48675	70800	—
160	7.3	—	—	—	1.71	3.07	5.75	8.09	—	—	—	—	15045	25665	48675	70800	—
180	6.5	—	—	—	1.54	2.69	5.15	7.24	—	—	—	—	15045	25665	48675	70800	—
200	5.9	—	—	—	1.39	2.48	4.51	6.35	—	—	—	—	15045	25665	48675	70800	—
224	5.2	—	—	—	—	2.15	4.16	5.85	—	—	—	—	—	25665	48675	70800	—
250	4.7	—	—	—	—	1.96	3.61	5.07	—	—	—	—	—	25665	48675	70800	—
280	4.2	—	—	—	—	1.64	3.28	4.62	—	—	—	—	—	25665	48675	70800	—
315	3.7	—	—	—	—	1.46	—	—	—	—	—	—	—	25665	—	—	—

300UJ — Gear Drive Horsepower and Torque Ratings

1170 High-Speed Shaft RPM/Quadruple and Quintuple Reduction (Torque is in lb-in at Low-Speed Shaft)

Ratio Code	Approx L.S. Shaft RPM	Horsepower									Torque								
		Drive Size									Drive Size								
		Quadruple			Quintuple			Quadruple			Quintuple								
		302	304	306	307	308	309	310	312	302	304	306	307	308	309	310	312		
100	11.7	0.39	0.71	1.40	—	—	—	—	—	2036	3894	7523	—	—	—	—	—		
112	10.4	0.33	0.67	1.31	—	—	—	—	—	2036	3894	7523	—	—	—	—	—		
125	9.4	0.29	0.58	1.13	—	—	—	—	—	2036	3894	7523	—	—	—	—	—		
140	8.4	0.27	0.50	0.98	—	—	—	—	—	2036	3894	7523	—	—	—	—	—		
160	7.3	0.23	0.47	0.91	—	—	—	—	—	2036	3894	7523	—	—	—	—	—		
180	6.5	0.22	0.40	0.76	1.53	—	—	—	14.1	2036	3894	7523	15045	—	—	—	132751		
200	5.9	0.18	0.37	0.72	1.33	—	—	—	12.1	2036	3894	7523	15045	—	—	—	132751		
224	5.2	0.17	0.32	0.64	1.23	—	—	—	10.8	2036	3894	7523	15045	—	—	—	132751		
250	4.7	0.15	0.29	0.55	1.14	—	—	—	9.50	2036	3894	7523	15045	—	—	—	132751		
280	4.2	0.14	0.26	0.50	0.97	1.65	3.32	4.70	8.66	2036	3894	7523	15045	25665	48675	70800	132751		
315	3.7	0.12	0.23	0.45	0.89	1.51	2.84	4.39	7.49	2036	3894	7523	15045	25665	48675	70800	132751		
355	3.3	0.10	0.20	0.41	0.75	1.27	2.63	3.76	6.78	2036	3894	7523	15045	25665	48675	70800	132751		
400	2.9	0.09	0.18	0.36	0.68	1.15	2.32	3.49	6.11	2036	3894	7523	15045	25665	48675	70800	132751		
450	2.6	0.08	0.16	0.32	0.61	1.04	2.05	3.07	5.70	2036	3894	7523	15045	25665	48675	70800	132751		
500	2.3	0.07	0.14	0.29	0.55	0.93	1.88	2.71	4.88	2036	3894	7523	15045	25665	48675	70800	132751		
560	2.1	0.07	0.13	0.25	0.49	0.83	1.62	2.49	4.53	2036	3894	7523	15045	25665	48675	70800	132751		
630	1.9	0.06	0.12	0.22	0.44	0.75	1.47	2.15	3.99	2036	3894	7523	15045	25665	48675	70800	132751		
710	1.6	0.06	0.10	0.19	0.39	0.67	1.23	1.95	3.52	2036	3894	7523	15045	25665	48675	70800	132751		
800	1.5	0.05	0.10	0.17	0.34	0.57	1.10	1.63	3.23	2036	3894	7523	15045	25665	48675	70800	132751		
900	1.3	—	0.08	0.15	0.30	0.52	1.00	1.46	2.79	—	3894	7523	15045	25665	48675	70800	132751		
1000 (10C)	1.2	—	—	0.14	0.29	0.50	0.90	1.32	2.58	—	—	7523	15045	25665	48675	70800	132751		
1120 (11C)	1.0	—	—	—	0.24	0.41	—	1.19	2.28	—	—	—	15045	25665	—	70800	132751		

300UJ — Gear Drive Horsepower and Torque Ratings

870 High-Speed Shaft RPM/Double Reduction (Torque is in lb-in at Low-Speed Shaft)

Ratio Code	Approx L.S. Shaft RPM	Horsepower								Torque							
		Drive Size								Drive Size							
		302	304	306	307	308	309	310	312	302	304	306	307	308	309	310	312
3.1	276	—	—	15.0	21.5	38.3	66.5	96.6	—	—	—	3230	5133	8850	15045	21771	—
3.5	245	5.81	—	12.9	21.6	38.1	64.6	91.9	—	1460	—	3230	5708	9735	16196	23453	—
4.0	218	5.08	—	12.9	20.9	38.2	59.7	86.9	—	1460	—	3629	6372	11240	17877	25134	—
4.5	193	4.73	5.78	11.4	19.8	36.8	59.2	81.6	—	1460	1947	3673	6815	12213	19028	26727	—
5.0	174	4.11	5.04	10.4	18.7	35.3	54.1	73.3	—	1460	1947	3673	7257	12965	20090	26205	—
5.6	155	3.56	4.71	9.05	17.3	33.5	51.1	71.3	—	1460	1947	3673	7700	13939	21240	29028	—
6.3	138	3.30	4.09	8.19	16.6	34.0	54.6	96.1	—	1460	1947	3673	8142	15842	25134	43542	—
7.1	123	3.06	3.54	7.38	14.1	32.5	52.3	91.2	—	1460	1947	3673	7611	16727	26727	46817	—
8.0	109	2.61	3.28	11.2	17.6	30.3	48.5	86.3	—	1460	1947	6549	10045	17966	29559	50180	—
9.0	96.7	3.32	5.61	10.4	16.6	28.3	47.0	80.3	—	2036	3806	7080	10620	18983	30710	52968	—
10.	87.0	2.90	4.95	9.90	15.1	27.2	43.5	77.6	—	2036	3850	7523	11151	20090	32922	55755	—
11.	77.7	2.70	4.67	8.65	14.2	24.7	40.9	70.1	—	2036	3894	7523	11859	20753	34604	57437	—
12.	69.6	2.35	4.06	7.88	13.1	22.7	39.7	66.5	—	2036	3894	7523	12302	21417	36285	59649	—
14.	62.1	2.03	3.51	6.82	11.8	21.0	36.9	59.8	—	2036	3894	7523	12744	22081	37967	61862	—
16.	54.4	1.75	3.26	6.17	11.0	19.2	34.5	56.2	—	2036	3894	7523	13098	22877	40179	64119	—
18.	48.3	1.49	3.02	5.56	10.3	18.3	33.0	51.3	—	2036	3894	7523	13496	23541	41861	65756	—
20.	43.5	1.37	2.57	5.19	9.47	17.0	30.3	47.7	—	2036	3894	7523	13939	24249	44073	68057	—
22.	38.8	1.25	2.37	4.44	8.90	15.4	27.7	43.9	—	2036	3894	7523	14514	25311	46817	70269	—
25.	34.8	1.14	1.98	4.12	8.05	13.8	25.9	39.2	—	2036	3894	7523	15045	25665	48675	70800	—
28.	31.1	1.04	1.80	3.63	6.85	12.1	24.3	34.8	—	2036	3894	7523	15045	25665	48675	70800	—
31.	27.6	0.94	1.62	3.20	6.41	11.1	21.8	30.2	—	2036	3894	7523	15045	25665	48675	70800	—
35.	24.5	0.75	1.46	2.94	5.74	9.69	19.3	27.6	—	2036	3894	7523	15045	25665	48675	70800	—
40.	21.8	0.67	1.30	2.54	5.03	8.94	17.6	25.5	—	2036	3894	7523	15045	25665	48675	70800	—
45.	19.3	0.60	1.17	2.30	4.64	7.57	15.4	21.6	—	2036	3894	7523	15045	25665	48675	70800	—
50.	17.4	0.57	1.04	1.92	4.02	6.79	14.1	19.5	—	2036	3894	7523	15045	25665	48675	70800	—
56.	15.5	0.52	0.90	1.73	3.66	5.68	12.0	17.5	—	2036	3894	7523	15045	23895	48675	70800	—
63.	13.8	0.47	0.80	1.56	3.06	—	10.8	—	—	2036	3894	7523	15045	—	48675	—	—
71.	12.3	0.37	0.65	1.40	2.65	—	9.81	—	—	2036	3230	7523	14603	—	48675	—	—
80.	10.9	0.34	0.53	1.33	—	—	—	—	—	2036	3186	7523	—	—	—	—	—
90.	9.7	0.30	0.44	1.21	—	—	—	—	—	2036	2965	7523	—	—	—	—	—
100	8.7	—	0.37	0.92	—	—	—	—	—	—	2744	7080	—	—	—	—	—

870 High-Speed Shaft RPM/Triple Reduction (Torque is in lb-in at Low-Speed Shaft)

Ratio Code	Approx L.S. Shaft RPM	Horsepower								Torque							
		Drive Size								Drive Size							
		302	304	306	307	308	309	310	312	302	304	306	307	308	309	310	312
8.0	219	—	—	—	—	—	—	—	70.0	—	—	—	—	—	—	—	38409
9.0	194	—	—	—	—	—	—	—	69.9	—	—	—	—	—	—	—	43454
10.	175	—	—	—	—	—	—	—	70.0	—	—	—	—	—	—	—	49206
11.	156	—	—	—	—	—	—	—	70.0	—	—	—	—	—	—	—	55844
12.	140	—	—	—	—	—	—	—	69.9	—	—	—	—	—	—	—	60844
14.	125	—	—	—	—	—	—	—	102.3	—	—	—	—	—	—	—	103546
16.	109	—	—	—	—	—	—	—	95.8	—	—	—	—	—	—	—	109741
18.	97.2	—	—	—	—	—	—	—	89.3	—	—	—	—	—	—	—	115936
20.	87.5	—	—	—	—	—	—	—	82.9	—	—	—	—	—	—	—	122131
22.	78.1	—	—	—	—	—	—	—	79.4	—	—	—	—	—	—	—	127441
25.	70.0	—	—	—	—	—	—	—	72.5	—	—	—	—	—	—	—	132751
28.	62.5	—	—	—	—	—	—	—	66.2	—	—	—	—	—	—	—	132751
31.	55.6	—	—	—	—	—	—	—	57.5	—	—	—	—	—	—	—	132751
35.	24.5	—	—	—	5.80	10.0	—	—	52.1	—	—	—	15045	24603	—	—	132751
40.	21.8	—	—	—	5.02	9.38	17.6	24.7	46.4	—	—	—	15045	25665	48675	70800	132751
45.	19.3	—	—	—	4.54	8.15	15.7	22.1	41.6	—	—	—	15045	25665	48675	70800	132751
50.	17.4	—	—	—	4.09	7.19	13.6	19.2	37.2	—	—	—	15045	25665	48675	70800	132751
56.	15.5	—	—	—	3.82	6.39	12.0	16.9	32.9	—	—	—	15045	25665	48675	70800	132751
63.	13.8	—	—	—	3.27	5.57	10.7	15.0	29.2	—	—	—	15045	25665	48675	70800	132751
71.	12.3	—	—	—	3.03	5.05	9.34	13.1	25.3	—	—	—	15045	25665	48675	70800	132751
80.	10.9	—	—	—	2.67	4.59	8.46	11.9	23.2	—	—	—	15045	25665	48675	70800	132751
90.	9.7	—	—	—	2.36	4.07	7.69	10.8	21.4	—	—	—	15045	25665	48675	70800	132751
100	8.7	—	—	—	2.16	3.67	6.83	9.61	18.1	—	—	—	15045	25665	48675	70800	132751
112	7.8	—	—	—	1.87	3.21	6.15	8.66	16.4	—	—	—	15045	25665	48675	70800	132751
125	7.0	—	—	—	1.69	2.73	5.38	7.56	14.7	—	—	—	15045	25665	48675	70800	132751
140	6.2	—	—	—	1.41	2.55	4.58	6.44	—	—	—	—	15045	25665	48675	70800	—
160	5.4	—	—	—	1.27	2.28	4.28	6.01	—	—	—	—	15045	25665	48675	70800	—
180	4.8	—	—	—	1.15	2.00	3.83	5.38	—	—	—	—	15045	25665	48675	70800	—
200	4.4	—	—	—	1.03	1.85	3.36	4.72	—	—	—	—	15045	25665	48675	70800	—
224	3.9	—	—	—	—	1.60	3.09	4.35	—	—	—	—	—	25665	48675	70800	—
250	3.5	—	—	—	—	1.46	2.68	3.77	—	—	—	—	—	25665	48675	70800	—
280	3.1	—	—	—	—	1.22	2.44	3.44	—	—	—	—	—	25665	48675	70800	—
315	2.8	—	—	—	—	1.09	—	—	—	—	—	—	—	25665	—	—	—

300UJ — Gear Drive Horsepower and Torque Ratings

870 High-Speed Shaft RPM/Quadruple and Quintuple Reduction (Torque is in lb-in at Low-Speed Shaft)

Ratio Code	Approx L.S. Shaft RPM	Horsepower									Torque								
		Drive Size									Drive Size								
		Quadruple					Quintuple				Quadruple					Quintuple			
		302	304	306	307	308	309	310	312	302	304	306	307	308	309	310	312		
100	8.7	0.29	0.53	1.04	—	—	—	—	—	2036	3894	7523	—	—	—	—	—		
112	7.8	0.25	0.50	0.97	—	—	—	—	—	2036	3894	7523	—	—	—	—	—		
125	7.0	0.22	0.43	0.84	—	—	—	—	—	2036	3894	7523	—	—	—	—	—		
140	6.2	0.20	0.37	0.73	—	—	—	—	—	2036	3894	7523	—	—	—	—	—		
160	5.4	0.17	0.35	0.68	—	—	—	—	—	2036	3894	7523	—	—	—	—	—		
180	4.8	0.16	0.30	0.57	1.14	—	—	—	10.5	2036	3894	7523	15045	—	—	—	132751		
200	4.4	0.14	0.28	0.53	0.99	—	—	—	9.05	2036	3894	7523	15045	—	—	—	132751		
224	3.9	0.13	0.24	0.47	0.91	—	—	—	8.09	2036	3894	7523	15045	—	—	—	132751		
250	3.5	0.11	0.22	0.41	0.85	—	—	—	7.06	2036	3894	7523	15045	—	—	—	132751		
280	3.1	0.10	0.20	0.37	0.72	1.23	2.47	3.50	6.44	2036	3894	7523	15045	25665	48675	70800	132751		
315	2.8	0.09	0.17	0.34	0.66	1.13	2.11	3.27	5.57	2036	3894	7523	15045	25665	48675	70800	132751		
355	2.5	0.08	0.15	0.30	0.56	0.94	1.96	2.79	5.04	2036	3894	7523	15045	25665	48675	70800	132751		
400	2.2	0.07	0.13	0.27	0.50	0.86	1.72	2.59	4.54	2036	3894	7523	15045	25665	48675	70800	132751		
450	1.9	0.06	0.12	0.24	0.46	0.77	1.52	2.28	4.24	2036	3894	7523	15045	25665	48675	70800	132751		
500	1.7	0.06	0.11	0.21	0.41	0.69	1.40	2.02	3.63	2036	3894	7523	15045	25665	48675	70800	132751		
560	1.6	0.05	0.10	0.19	0.36	0.62	1.21	1.85	3.37	2036	3894	7523	15045	25665	48675	70800	132751		
630	1.4	0.05	0.09	0.17	0.33	0.56	1.09	1.60	2.96	2036	3894	7523	15045	25665	48675	70800	132751		
710	1.2	0.04	0.07	0.14	0.29	0.50	0.91	1.45	2.62	2036	3894	7523	15045	25665	48675	70800	132751		
800	1.1	0.03	0.07	0.13	0.25	0.43	0.82	1.21	2.40	2036	3894	7523	15045	25665	48675	70800	132751		
900	1.0	—	0.06	0.11	0.23	0.38	0.74	1.09	2.07	—	3894	7523	15045	25665	48675	70800	132751		
1000 (10C)	0.9	—	—	0.10	0.22	0.37	0.67	0.98	1.92	—	—	7523	15045	25665	48675	70800	132751		
1120 (11C)	0.8	—	—	—	0.18	0.31	—	0.88	1.69	—	—	—	15045	25665	—	70800	132751		

300UJ — Gear Drive Thermal Horsepower Ratings

Thermal ratings are a measure of the units ability to dissipate heat, if they are exceeded the lubricant may break down resulting in premature gear failure.

Thermal ratings are based on an ambient temperature of 68°F, when units are to operate at other ambient temperatures the thermal HP ratings must be multiplied by the following factors.

UJ Thermal Ratings & Thermal Application Correction Factors

The thermal ratings are a measure of the gear drive's ability to dissipate heat. Checking the thermal rating is extremely important, for if the drive creates heat faster than it can be dissipated, severe damage may occur.

Quick Selection tables for gearmotor drives are based on mechanical ratings only, while horsepower and torque tables show both mechanical and thermal ratings. It is important, however, that for both types of drives, the thermal ratings are checked to ensure that overheating does not occur.

Catalog thermal ratings are based on the drive being mounted in Position #1, operating continuously in an environment with an ambient temperature equal to 68°F (20°C). The thermal rating is affected by ambient air temperature, duty cycle and mounting position. To account for these varying conditions, the application correction factors given in the tables to the right for B₁ and B₂ should be applied to the catalog thermal ratings using the following formula:

$$P_{TA} = B_1 \times B_2 \times P_T \text{ where:}$$

P_{TA} = Application Adjusted Thermal Power Rating

P_T = Basic Thermal Power Rating (Below)

B₁ = Ambient Air Temperature Factor (Right)

B₂ = Duty Cycle Factor (Right)

Ambient Adjustment Factor — B₁

Drive Size	Ambient Temperature °F							
	-4	14	32	50	68	86	104	122
All Units	1.57	1.43	1.29	1.14	1.0	0.86	0.71	0.5

Duty Cycle Factor ■ — B₂

Drive Output rpm	% Operating Time Per Hour				
	100	80	60	40	20
0 to 10	1.00	1.18	1.45	1.72	2.38
>10 to 25	1.00	1.16	1.39	1.64	2.22
>25 to 50	1.00	1.14	1.31	1.54	2.00
>50 to 100	1.00	1.08	1.19	1.33	1.64
>100 to 150	1.00	1.04	1.08	1.19	1.41
>150 to 200	1.00	1.00	1.00	1.06	1.23
>200	1.00	1.00	1.00	1.00	1.00

■ The duty cycle factor must be based on the percentage of each hour that the drive is operating. For example: A gear drive operating for 48 minutes and resting for 12 minutes every hour of the day, has an 80% duty cycle, but a drive operating for four hours and resting for four hours has a 100% duty cycle. Where % run time per hour falls between values shown above, use next higher % run time.

300UJ — Gear Drive Thermal Horsepower Ratings ●

Overall Ratio	High-Speed Shaft RPM	Drive Size				
		307	308	309	310	312 ▲
3.15 to 5	1750	29	52	74	90	—
	1430	28	51	73	90	—
	1170	26	50	70	90	—
	870	24	49	65	90	—
5.6 to 9	1750	27	50	66.4	90	—
	1430	24	48	64	90	—
	1170	23	47	62	90	—
	870	22	46	59	87	—
10 to 16	1750	24	45.4	60.4	90	—
	1430	22	43	58	88	—
	1170	21	42	56	80	—
	870	20	41	52	72	—
18 to 28	1750	20	38	51	75	—
	1430	19	36	49	65	—
	1170	18	36	47	55	—
	870	18	36	43	50	—
31.5 to 50	1750	16	29.6	45	60	—
	1430	16	29	44	50	—
	1170	15	29	43	40	—
	870	15	29	40	35	—
56 to 100	1750	15	28	—	—	—
	1430	15	28	—	—	—
	1170	15	28	—	—	—
	870	15	28	—	—	—

● All Thermal Ratings listed are for double reduction units. If the thermal rating isn't listed in this table (includes all triple reduction configurations), Thermal Power >> Mechanical Power.

▲ 312 Drive Size only available in triple reduction.

300UJ — Double & Triple Reduction Gear Drive/Straight Hollow Shaft

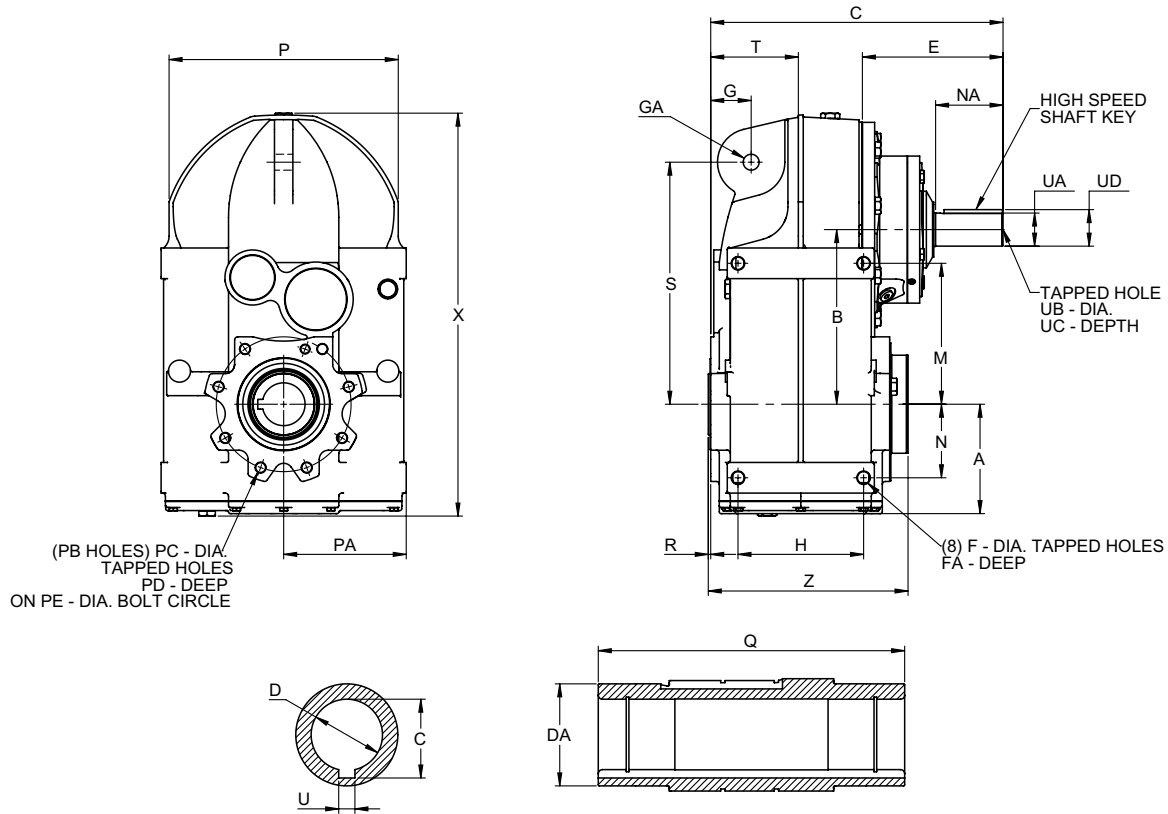

Type UJ Gear Drive — Straight Hollow Shaft — 300UJAQ (Dimensions—Inches)

Size	A	B	C	D	DA	F	FA	G	GA	H	M	N	P
302	3.07	4.53	1.12	1.000+0.0008, -0	1.77	M8	0.51	1.20	0.55	3.03	3.31	1.22	5.51
			1.37	1.250+0.0010, -0									
304	3.39	4.82	1.37	1.250+0.0010, -0	1.97	M10	0.83	1.18	0.55	3.66	4.02	1.69	5.51
			1.52	1.375+0.0010, -0									
306	4.11	6.84	1.67	1.500+0.0010, -0	2.17	M12	0.71	1.54	0.55	4.41	5.19	2.36	7.40
307	4.89	8.61	2.23	2.000+0.0012, -0	2.76	M16	1.02	1.87	0.87	5.51	6.69	2.76	10.63
308	5.93	9.47	2.66	2.375+0.0012, -0	3.35	M16	1.02	2.34	0.87	6.50	8.27	3.94	11.38
309	7.03	11.22	3.04	2.750+0.0012, -0	3.94	M20	1.10	2.60	1.02	8.07	9.06	4.72	14.72
310	7.70	13.27	3.59	3.250+0.0014, -0	4.72	M24	1.42	2.83	1.02	8.66	10.83	4.92	15.98
312	8.66	14.57	4.45	4.000+0.0014, -0	5.51	M30	1.77	3.74	1.30	10.63	15.67	5.59	17.64

Size	PA	PB	PC	PD	PE	Q	R	S	T	U	X	Z
302	3.24	5.00	M8	0.51	3.70	4.72	0.08	6.22	2.24	0.25	10.47	5.17
304	3.54	7.00	M8	0.51	4.72	5.91	0.08	6.69	2.89	0.25	11.16	6.35
306	4.17	6.00	M12	0.71	4.92	7.09	0.08	8.58	3.52	0.38	14.82	7.62
307	5.31	8.00	M12	0.87	5.59	8.27	0.10	10.94	3.98	0.50	18.90	8.78
308	6.50	6.00	M16	1.02	7.01	9.45	0.10	13.62	4.70	0.63	21.11	10.06
309	7.87	8.00	M16	1.22	8.66	11.81	0.16	15.55	5.63	0.63	25.89	12.83
310	8.86	8.00	M20	1.18	10.24	13.78	0.63	19.09	6.28	0.75	29.51	14.33
312	10.43	11.00	M20	1.10	11.81	16.14	0.59	3.74	7.60	1.00	34.11	16.73

Indicates alternate LS shaft bore.

SOLID INPUT — Double & Triple Reduction

Size	Ratio Range	Drive Size								
		C	E	NA	UA	UB	UC	UD	High Speed Shaft Key	
302	3.5-90	8.41	4.35	1.57	0.625 - 0.0005	N/A	N/A	0.71	0.1875 x 0.1875 x 1.25	
304	4.5-100	9.19	4.35	1.57	0.625 - 0.0005	N/A	N/A	0.71	0.1875 x 0.1875 x 1.25	
306	3.1-5.6 & 8-14 & 63-100	10.47	4.84	2.36	1.125 - 0.0005	0.375-16 UNC-2B	1.38	1.24	0.250 x 0.250 x 2.75	
	6.3-7.1 & 16-56	11.26	5.63	3.15	1.375 - 0.0005	0.500-13 UNC-2B	1.65	1.51	0.3125 x 0.3125 x 2.75	
307	3.1-71 & 35-160	13.15	5.79	3.15	1.375 - 0.0005	0.500-13 UNC-2B	1.65	1.51	0.3125 x 0.3125 x 2.75	
308	3.1-56 & 35-315	14.00	5.79	3.15	1.375 - 0.0005	0.500-13 UNC-2B	1.65	1.51	0.3125 x 0.3125 x 2.75	
309	56-71 & 90-280	15.22	5.49	3.15	1.375 - 0.0005	0.500-13 UNC-2B	1.65	1.51	0.3125 x 0.3125 x 2.75	
	3.1-50 & 40-80	18.78	9.06	4.33	2.125 - 0.0009	0.750-10 UNC-2B	2.13	2.35	0.500 x 0.500 x 3.75	
310	90-280	16.44	5.49	3.15	1.375 - 0.0005	0.500-13 UNC-2B	1.65	1.51	0.3125 x 0.3125 x 2.75	
	3.1-56 & 40-80	20.00	9.06	4.33	2.125 - 0.0009	0.750-10 UNC-2B	2.13	2.35	0.500 x 0.500 x 3.75	
312	8-125	23.86	9.06	4.33	2.125 - 0.0009	0.750-10 UNC-2B	2.13	2.35	0.500 x 0.500 x 3.75	

300UJ — Quadruple & Quintuple Reduction Gear Drive/Straight Hollow Shaft

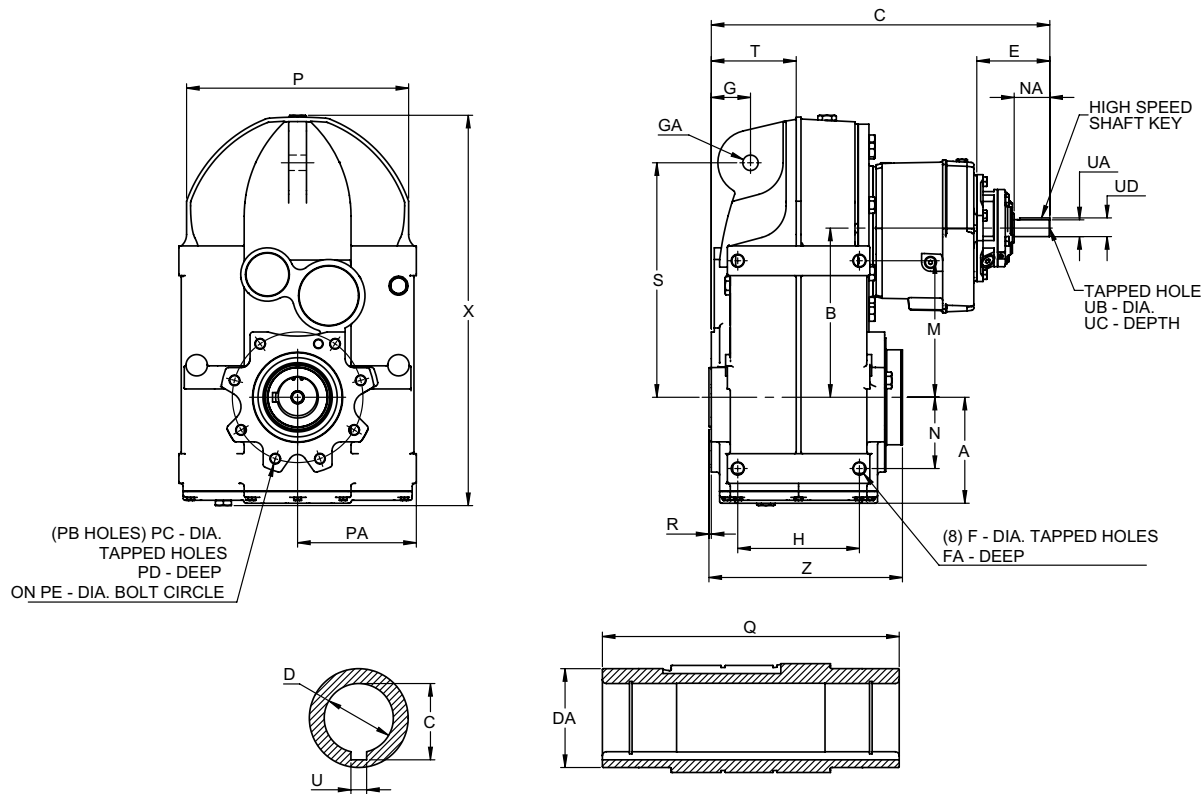

Type UJ Gear Drive — Straight Hollow Shaft — 300UJAQ (Dimensions—Inches)

Size	A	B	C	D	DA	F	FA	G	GA	H	M	N	P
302	3.07	4.53	1.12	1.000+0.0008, -0	1.77	M8	0.51	1.20	0.55	3.03	3.31	1.22	5.51
			1.37	1.250+0.0010, -0									
304	3.39	4.82	1.37	1.250+0.0010, -0	1.97	M10	0.83	1.18	0.55	3.66	4.02	1.69	5.51
			1.52	1.375+0.0010, -0									
306	4.11	6.84	1.67	1.500+0.0010, -0	2.17	M12	0.71	1.54	0.55	4.41	5.19	2.36	7.40
307	4.89	8.61	2.23	2.000+0.0012, -0	2.76	M16	1.02	1.87	0.87	5.51	6.69	2.76	10.63
308	5.93	9.47	2.66	2.375+0.0012, -0	3.35	M16	1.02	2.34	0.87	6.50	8.27	3.94	11.38
309	7.03	11.22	3.04	2.750+0.0012, -0	3.94	M20	1.10	2.60	1.02	8.07	9.06	4.72	14.72
310	7.70	13.27	3.59	3.250+0.0014, -0	4.72	M24	1.42	2.83	1.02	8.66	10.83	4.92	15.98
312	8.66	14.57	4.45	4.000+0.0014, -0	5.51	M30	1.77	3.74	1.30	10.63	15.67	5.59	17.64

Size	PA	PB	PC	PD	PE	Q	R	S	T	U	X	Z
302	3.24	5.00	M8	0.51	3.70	4.72	0.08	6.22	2.24	0.25	10.47	5.17
304	3.54	7.00	M8	0.51	4.72	5.91	0.08	6.69	2.89	0.25	11.16	6.35
306	4.17	6.00	M12	0.71	4.92	7.09	0.08	8.58	3.52	0.38	14.82	7.62
307	5.31	8.00	M12	0.87	5.59	8.27	0.10	10.94	3.98	0.50	18.90	8.78
308	6.50	6.00	M16	1.02	7.01	9.45	0.10	13.62	4.70	0.63	21.11	10.06
309	7.87	8.00	M16	1.22	8.66	11.81	0.16	15.55	5.63	0.63	25.89	12.83
310	8.86	8.00	M20	1.18	10.24	13.78	0.63	19.09	6.28	0.75	29.51	14.33
312	10.43	11.00	M20	1.10	11.81	16.14	0.59	3.74	7.60	1.00	34.11	16.73

Indicates alternate LS shaft bore.

SOLID INPUT — Quadruple & Quintuple Reduction

Size	Ratio Range	Drive Size							
		C	E	NA	UA	UB	UC	UD	High Speed Shaft Key
302	99-800	15.06	4.35	1.57	0.625 - 0.0005	N/A	N/A	0.71	0.1875 x 0.1875 x 1.25
304	100-900	15.87	4.35	1.57	0.625 - 0.0005	N/A	N/A	0.71	0.1875 x 0.1875 x 1.25
306	100-10C	16.30	4.35	1.57	0.625 - 0.0005	N/A	N/A	0.71	0.1875 x 0.1875 x 1.25
307	180-11C	17.56	4.35	1.57	0.625 - 0.0005	N/A	N/A	0.71	0.1875 x 0.1875 x 1.25
308	280-11C	18.41	4.35	1.57	0.625 - 0.0005	N/A	N/A	0.71	0.1875 x 0.1875 x 1.25
309	140-200 & 900-10C	22.45	4.84	2.36	1.125 - 0.0005	0.375-16 UNC-2B	1.375	1.24	0.250 x 0.250 x 2.75
	224-800	23.24	5.63	3.15	1.375 - 0.0005	0.500-13 UNC-2B	1.65	1.51	0.3125 x 0.3125 x 2.75
310	125-224 & 10C-11C	23.67	4.84	2.36	1.125 - 0.0005	0.375-16 UNC-2B	1.375	1.24	0.250 x 0.250 x 2.75
	250-900	24.46	5.63	3.15	1.375 - 0.0005	0.500-13 UNC-2B	1.65	1.51	0.3125 x 0.3125 x 2.75
312	180-315	27.53	4.84	2.36	1.125 - 0.0005	0.375-16 UNC-2B	1.375	1.24	0.250 x 0.250 x 2.75
	355-11C	28.31	5.63	3.15	1.375 - 0.0005	0.500-13 UNC-2B	1.65	1.51	0.3125 x 0.3125 x 2.75

300UJ — Double & Triple Reduction Gear Drive/Hollow Shaft with TA Taper Bushing

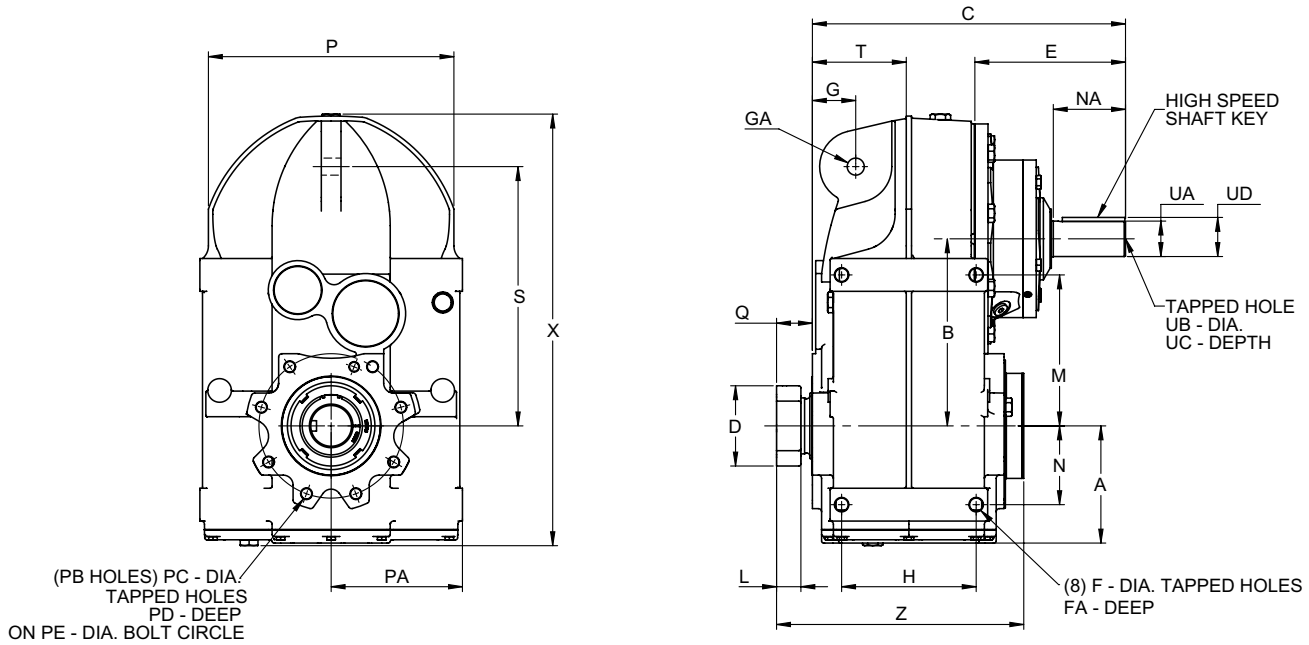

Type UJ Gearmotor — Hollow Shaft with TA Taper Bushing — 300UJAN (Dimensions—Inch)

Size*	A	B	D	F	FA	G	GA	H	L	M	N	P	PA	PB	PC	PD	PE	Q	S	T	X	Z
306	4.11	6.84	3.31	M12	0.71	1.54	0.55	4.41	1.26	5.19	2.36	7.40	4.17	6.00	M12	0.71	4.92	1.85	8.58	3.52	14.82	9.40
307	4.89	8.61	4.06	M16	1.02	1.87	0.87	5.51	1.46	6.69	2.76	10.63	5.31	8.00	M12	0.87	5.59	2.13	10.94	3.98	18.90	10.76
308	5.93	9.47	4.81	M16	1.02	2.34	0.87	6.50	1.46	8.27	3.94	11.38	6.50	6.00	M16	1.02	7.01	2.15	13.62	4.70	21.11	12.11
309	7.03	11.22	4.81	M20	1.10	2.60	1.02	8.07	1.46	9.06	4.72	14.72	7.87	8.00	M16	1.22	8.66	2.15	15.55	5.63	25.89	14.83
310	7.70	13.27	6.06	M24	1.42	2.83	1.02	8.66	1.76	10.83	4.92	15.98	8.86	8.00	M20	1.18	10.24	2.55	19.09	6.28	29.51	16.25
312	8.66	14.57	6.81	M30	1.77	3.74	1.30	10.63	1.80	15.67	5.59	17.64	10.43	11.00	M20	1.10	11.81	2.64	3.74	7.60	34.85	18.78

★ For Hollow L.S. Shaft Dimensions, refer to TA Taper Bushing Dimensions on pages 40-41.

SOLID INPUT — Double & Triple Reduction

Size	Ratio Range	Drive Size							
		C	E	NA	UA	UB	UC	UD	High Speed Shaft Key
302	3.5-90	8.41	4.35	1.57	0.625 - 0.0005	N/A	N/A	0.71	0.1875 x 0.1875 x 1.25
304	4.5-100	9.19	4.35	1.57	0.625 - 0.0005	N/A	N/A	0.71	0.1875 x 0.1875 x 1.25
306	3.1-5.6 & 8-14 & 63-100	10.47	4.84	2.36	1.125 - 0.0005	0.375-16 UNC-2B	1.38	1.24	0.250 x 0.250 x 2.75
	6.3-7.1 & 16-56	11.26	5.63	3.15	1.375 - 0.0005	0.500-13 UNC-2B	1.65	1.51	0.3125 x 0.3125 x 2.75
307	3.1-71 & 35-160	13.15	5.79	3.15	1.375 - 0.0005	0.500-13 UNC-2B	1.65	1.51	0.3125 x 0.3125 x 2.75
308	3.1-56 & 35-315	14.00	5.79	3.15	1.375 - 0.0005	0.500-13 UNC-2B	1.65	1.51	0.3125 x 0.3125 x 2.75
309	56-71 & 90-280	15.22	5.49	3.15	1.375 - 0.0005	0.500-13 UNC-2B	1.65	1.51	0.3125 x 0.3125 x 2.75
	3.1-50 & 40-80	18.78	9.06	4.33	2.125 - 0.0009	0.750-10 UNC-2B	2.13	2.35	0.500 x 0.500 x 3.75
310	90-280	16.44	5.49	3.15	1.375 - 0.0005	0.500-13 UNC-2B	1.65	1.51	0.3125 x 0.3125 x 2.75
	3.1-56 & 40-80	20.00	9.06	4.33	2.125 - 0.0009	0.750-10 UNC-2B	2.13	2.35	0.500 x 0.500 x 3.75
312	8-125	23.86	9.06	4.33	2.125 - 0.0009	0.750-10 UNC-2B	2.13	2.35	0.500 x 0.500 x 3.75

300UJ — Quadruple & Quintuple Reduction Gear Drive/Hollow Shaft with TA Taper Bushing

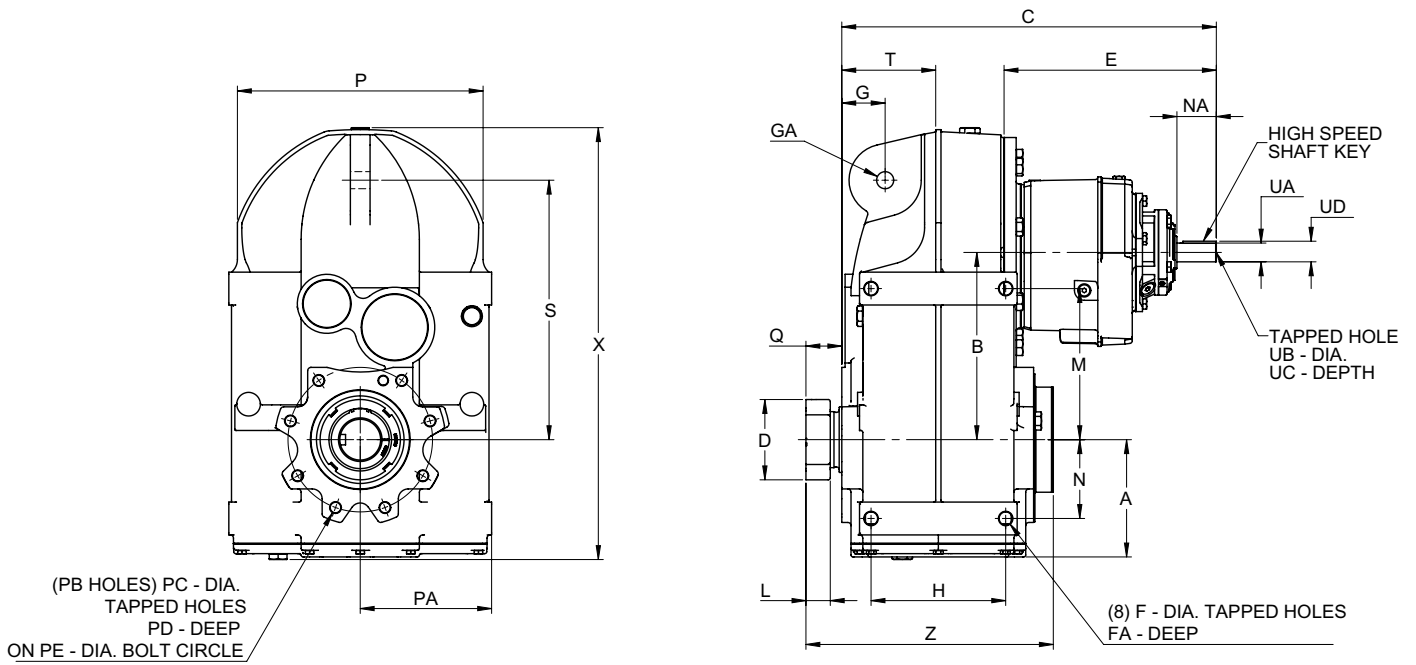

Type UJ Gearmotor — Hollow Shaft with TA Taper Bushing — 300UJAN (Dimensions—Inch)

Size*	A	B	D	F	FA	G	GA	H	L	M	N	P	PA	PB	PC	PD	PE	Q	S	T	X	Z
306	4.11	6.84	3.31	M12	0.71	1.54	0.55	4.41	1.26	5.19	2.36	7.40	4.17	6.00	M12	0.71	4.92	1.85	8.58	3.52	14.82	9.40
307	4.89	8.61	4.06	M16	1.02	1.87	0.87	5.51	1.46	6.69	2.76	10.63	5.31	8.00	M12	0.87	5.59	2.13	10.94	3.98	18.90	10.76
308	5.93	9.47	4.81	M16	1.02	2.34	0.87	6.50	1.46	8.27	3.94	11.38	6.50	6.00	M16	1.02	7.01	2.15	13.62	4.70	21.11	12.11
309	7.03	11.22	4.81	M20	1.10	2.60	1.02	8.07	1.46	9.06	4.72	14.72	7.87	8.00	M16	1.22	8.66	2.15	15.55	5.63	25.89	14.83
310	7.70	13.27	6.06	M24	1.42	2.83	1.02	8.66	1.76	10.83	4.92	15.98	8.86	8.00	M20	1.18	10.24	2.55	19.09	6.28	29.51	16.25
312	8.66	14.57	6.81	M30	1.77	3.74	1.30	10.63	1.80	15.67	5.59	17.64	10.43	11.00	M20	1.10	11.81	2.64	3.74	7.60	34.85	18.78

★ For Hollow L.S. Shaft Dimensions, refer to TA Taper Bushing Dimensions on pages 40-41.

SOLID INPUT — Quadruple & Quintuple Reduction

Size	Ratio Range	Drive Size							
		C	E	NA	UA	UB	UC	UD	High Speed Shaft Key
302	99-800	15.06	4.35	1.57	0.625 - 0.0005	N/A	N/A	0.71	0.1875 x 0.1875 x 1.25
304	100-900	15.87	4.35	1.57	0.625 - 0.0005	N/A	N/A	0.71	0.1875 x 0.1875 x 1.25
306	100-10C	16.30	4.35	1.57	0.625 - 0.0005	N/A	N/A	0.71	0.1875 x 0.1875 x 1.25
307	180-11C	17.56	4.35	1.57	0.625 - 0.0005	N/A	N/A	0.71	0.1875 x 0.1875 x 1.25
308	280-11C	18.41	4.35	1.57	0.625 - 0.0005	N/A	N/A	0.71	0.1875 x 0.1875 x 1.25
309	140-200 & 900-10C	22.45	4.84	2.36	1.125 - 0.0005	0.375-16 UNC-2B	1.375	1.24	0.250 x 0.250 x 2.75
	224-800	23.24	5.63	3.15	1.375 - 0.0005	0.500-13 UNC-2B	1.65	1.51	0.3125 x 0.3125 x 2.75
310	125-224 & 10C-11C	23.67	4.84	2.36	1.125 - 0.0005	0.375-16 UNC-2B	1.375	1.24	0.250 x 0.250 x 2.75
	250-900	24.46	5.63	3.15	1.375 - 0.0005	0.500-13 UNC-2B	1.65	1.51	0.3125 x 0.3125 x 2.75
312	180-315	27.53	4.84	2.36	1.125 - 0.0005	0.375-16 UNC-2B	1.375	1.24	0.250 x 0.250 x 2.75
	355-11C	28.31	5.63	3.15	1.375 - 0.0005	0.500-13 UNC-2B	1.65	1.51	0.3125 x 0.3125 x 2.75

300UJ — Double & Triple Reduction Gear Drive/Inch Single-Ended

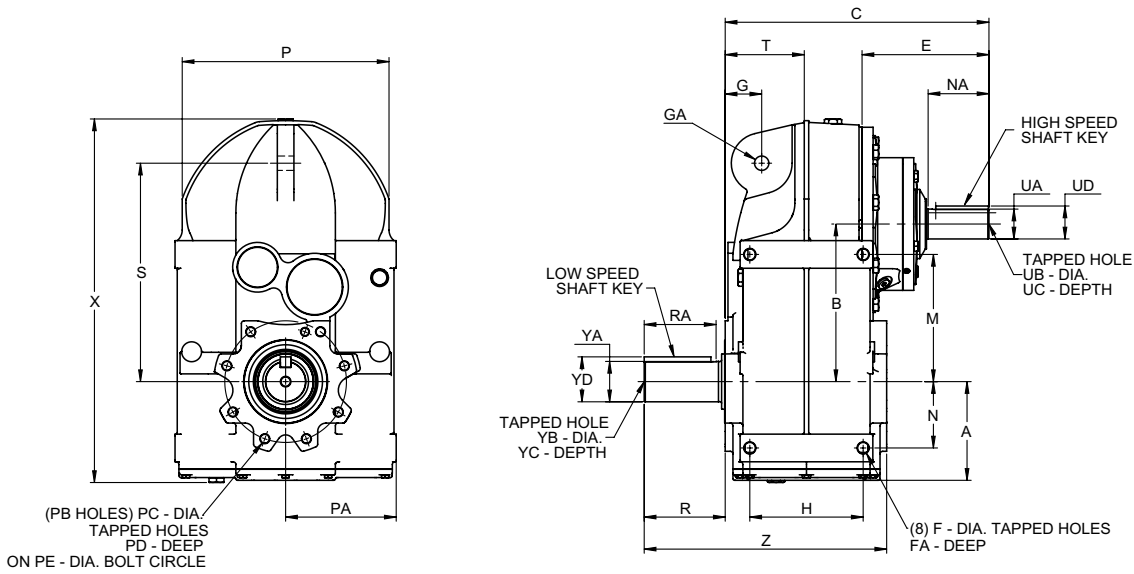

Type UJ Gear Drive— Solid Shaft Single-Ended — 300UJAK (Dimensions—Inch)

Size	A	B	F	FA	G	GA	H	M	N	P	PA	PB	PC	PD	PE	R	RA	S	T	X	Z
302	3.07	4.53	M8	0.51	1.20	0.55	3.03	3.31	1.22	5.51	3.24	5.00	M8	0.51	3.70	2.05	1.97	6.22	2.24	10.47	6.61
304	3.39	4.82	M10	0.83	1.18	0.55	3.66	4.02	1.69	5.51	3.54	7.00	M8	0.51	4.72	2.44	2.36	6.69	2.89	11.16	8.19
306	4.11	6.84	M12	0.71	1.54	0.55	4.41	5.19	2.36	7.40	4.17	6.00	M12	0.71	4.92	3.27	3.15	8.58	3.52	14.82	10.20
307	4.89	8.61	M16	1.02	1.87	0.87	5.51	6.69	2.76	10.63	5.31	8.00	M12	0.87	5.59	4.07	3.94	10.94	3.98	18.90	12.15
308	5.93	9.47	M16	1.02	2.34	0.87	6.50	8.27	3.94	11.38	6.50	6.00	M16	1.02	7.01	4.82	4.72	13.62	4.70	21.11	14.14
309	7.03	11.22	M20	1.10	2.60	1.02	8.07	9.06	4.72	14.72	7.87	8.00	M16	1.22	8.66	5.77	5.51	15.55	5.63	25.89	17.26
310	7.70	13.27	M24	1.42	2.83	1.02	8.66	10.83	4.92	15.98	8.86	8.00	M20	1.18	10.24	7.40	6.69	19.09	6.28	29.51	19.92
312	8.66	14.57	M30	1.77	3.74	1.30	10.63	15.67	5.59	17.64	10.43	11.00	M20	1.10	11.81	8.98	8.27	3.74	7.60	34.11	23.94

Size	LOW SPEED SHAFT				
	YA	YB	YC	YD	KEY
302	1.000 +0.000, -0.013	0.375-16 UNC-2B	1.375	1.11	0.25 x 0.25 x 1.75
304	1.250 +0.000, -0.013	0.375-16 UNC-2B	1.375	1.36	0.25 x 0.25 x 2.00
306	1.625 +0.000, -0.025	0.625-11 UNC-2B	1.875	1.79	0.375 x 0.375 x 2.50
307	2.000 +0.000, -0.025	0.750-10 UNC-2B	2.125	2.22	0.50 x 0.50 x 3.25
308	2.375 +0.000, -0.025	0.750-10 UNC-2B	2.125	2.65	0.625 x 0.625 x 4.0
309	2.875 +0.000, -0.025	0.750-10 UNC-2B	2.125	3.20	0.75 x 0.75 x 4.75
310	3.625 +0.000, -0.025	1.000-8 UNC-2B	2.625	4.01	0.875 x 0.875 x 5.75
312	4.375 +0.000, -0.025	1.000-8 UNC-2B	2.625	4.82	1.00 x 1.00 x 7.50

SOLID INPUT — Double & Triple Reduction

Size	Ratio Range	Drive Size							
		C	E	NA	UA	UB	UC	UD	High Speed Shaft Key
302	3.5-90	8.41	4.35	1.57	0.625 - 0.0005	N/A	N/A	0.71	0.1875 x 0.1875 x 1.25
304	4.5-100	9.19	4.35	1.57	0.625 - 0.0005	N/A	N/A	0.71	0.1875 x 0.1875 x 1.25
306	3.1-5.6 & 8-14 & 63-100	10.47	4.84	2.36	1.125 - 0.0005	0.375-16 UNC-2B	1.38	1.24	0.250 x 0.250 x 2.75
	6.3-7.1 & 16-56	11.26	5.63	3.15	1.375 - 0.0005	0.500-13 UNC-2B	1.65	1.51	0.3125 x 0.3125 x 2.75
307	3.1-71 & 35-160	13.15	5.79	3.15	1.375 - 0.0005	0.500-13 UNC-2B	1.65	1.51	0.3125 x 0.3125 x 2.75
308	3.1-56 & 35-315	14.00	5.79	3.15	1.375 - 0.0005	0.500-13 UNC-2B	1.65	1.51	0.3125 x 0.3125 x 2.75
309	56-71 & 90-280	15.22	5.49	3.15	1.375 - 0.0005	0.500-13 UNC-2B	1.65	1.51	0.3125 x 0.3125 x 2.75
	3.1-50 & 40-80	18.78	9.06	4.33	2.125 - 0.0009	0.750-10 UNC-2B	2.13	2.35	0.500 x 0.500 x 3.75
310	90-280	16.44	5.49	3.15	1.375 - 0.0005	0.500-13 UNC-2B	1.65	1.51	0.3125 x 0.3125 x 2.75
	3.1-56 & 40-80	20.00	9.06	4.33	2.125 - 0.0009	0.750-10 UNC-2B	2.13	2.35	0.500 x 0.500 x 3.75
312	8-125	23.86	9.06	4.33	2.125 - 0.0009	0.750-10 UNC-2B	2.13	2.35	0.500 x 0.500 x 3.75

300UJ — Quadruple & Quintuple Reduction Gear Drive/Inch Single-Ended

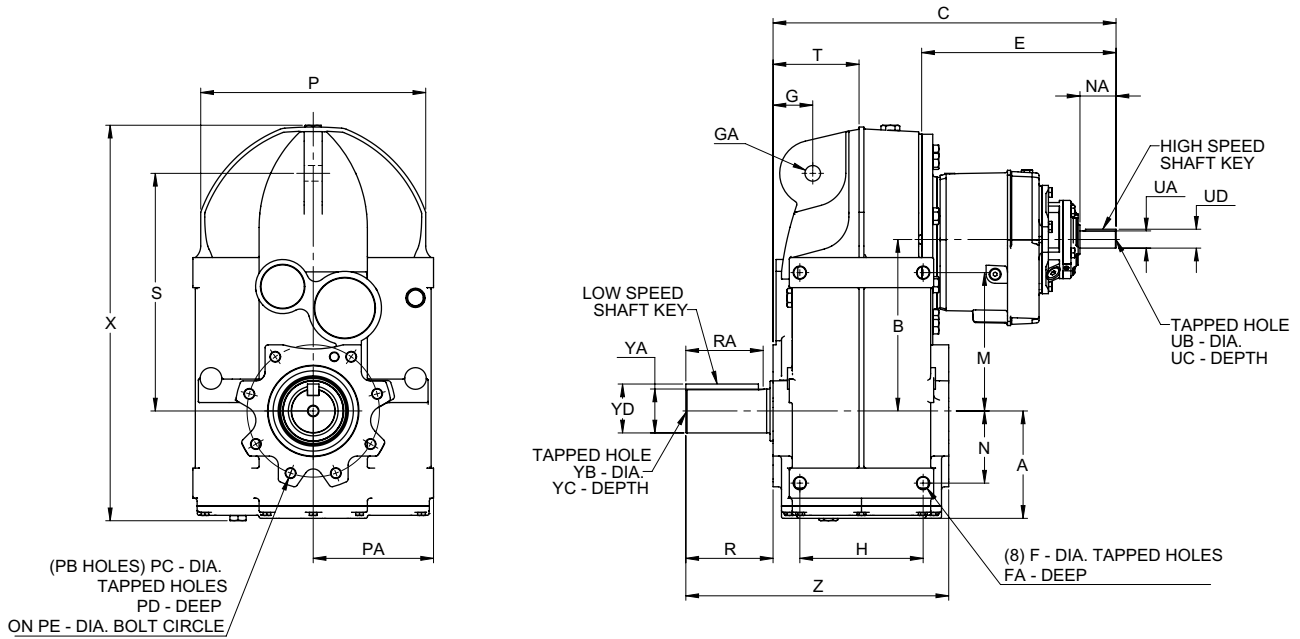

Type UJ Gear Drive— Solid Shaft Single-Ended — 300UJAK (Dimensions—Inch)

Size	A	B	F	FA	G	GA	H	M	N	P	PA	PB	PC	PD	PE	R	RA	S	T	X	Z
302	3.07	4.53	M8	0.51	1.20	0.55	3.03	3.31	1.22	5.51	3.24	5.00	M8	0.51	3.70	2.05	1.97	6.22	2.24	10.47	6.61
304	3.39	4.82	M10	0.83	1.18	0.55	3.66	4.02	1.69	5.51	3.54	7.00	M8	0.51	4.72	2.44	2.36	6.69	2.89	11.16	8.19
306	4.11	6.84	M12	0.71	1.54	0.55	4.41	5.19	2.36	7.40	4.17	6.00	M12	0.71	4.92	3.27	3.15	8.58	3.52	14.82	10.20
307	4.89	8.61	M16	1.02	1.87	0.87	5.51	6.69	2.76	10.63	5.31	8.00	M12	0.87	5.59	4.07	3.94	10.94	3.98	18.90	12.15
308	5.93	9.47	M16	1.02	2.34	0.87	6.50	8.27	3.94	11.38	6.50	6.00	M16	1.02	7.01	4.82	4.72	13.62	4.70	21.11	14.14
309	7.03	11.22	M20	1.10	2.60	1.02	8.07	9.06	4.72	14.72	7.87	8.00	M16	1.22	8.66	5.77	5.51	15.55	5.63	25.89	17.26
310	7.70	13.27	M24	1.42	2.83	1.02	8.66	10.83	4.92	15.98	8.86	8.00	M20	1.18	10.24	7.40	6.69	19.09	6.28	29.51	19.92
312	8.66	14.57	M30	1.77	3.74	1.30	10.63	15.67	5.59	17.64	10.43	11.00	M20	1.10	11.81	8.98	8.27	3.74	7.60	34.11	23.94

Size	LOW SPEED SHAFT				
	YA	YB	YC	YD	KEY
302	1.000 +0.000, -0.013	0.375-16 UNC-2B	1.375	1.11	0.25 x 0.25 x 1.75
304	1.250 +0.000, -0.013	0.375-16 UNC-2B	1.375	1.36	0.25 x 0.25 x 2.00
306	1.625 +0.000, -0.025	0.625-11 UNC-2B	1.875	1.79	0.375 x 0.375 x 2.50
307	2.000 +0.000, -0.025	0.750-10 UNC-2B	2.125	2.22	0.50 x 0.50 x 3.25
308	2.375 +0.000, -0.025	0.750-10 UNC-2B	2.125	2.65	0.625 x 0.625 x 4.0
309	2.875 +0.000, -0.025	0.750-10 UNC-2B	2.125	3.20	0.75 x 0.75 x 4.75
310	3.625 +0.000, -0.025	1.000-8 UNC-2B	2.625	4.01	0.875 x 0.875 x 5.75
312	4.375 +0.000, -0.025	1.000-8 UNC-2B	2.625	4.82	1.00 x 1.00 x 7.50

SOLID INPUT — Quadruple & Quintuple Reduction

Size	Ratio Range	Drive Size							
		C	E	NA	UA	UB	UC	UD	High Speed Shaft Key
302	99-800	15.06	4.35	1.57	0.625 - 0.0005	N/A	N/A	0.71	0.1875 x 0.1875 x 1.25
304	100-900	15.87	4.35	1.57	0.625 - 0.0005	N/A	N/A	0.71	0.1875 x 0.1875 x 1.25
306	100-10C	16.30	4.35	1.57	0.625 - 0.0005	N/A	N/A	0.71	0.1875 x 0.1875 x 1.25
307	180-11C	17.56	4.35	1.57	0.625 - 0.0005	N/A	N/A	0.71	0.1875 x 0.1875 x 1.25
308	280-11C	18.41	4.35	1.57	0.625 - 0.0005	N/A	N/A	0.71	0.1875 x 0.1875 x 1.25
309	140-200 & 900-10C	22.45	4.84	2.36	1.125 - 0.0005	0.375-16 UNC-2B	1.375	1.24	0.250 x 0.250 x 2.75
	224-800	23.24	5.63	3.15	1.375 - 0.0005	0.500-13 UNC-2B	1.65	1.51	0.3125 x 0.3125 x 2.75
310	125-224 & 10C-11C	23.67	4.84	2.36	1.125 - 0.0005	0.375-16 UNC-2B	1.375	1.24	0.250 x 0.250 x 2.75
	250-900	24.46	5.63	3.15	1.375 - 0.0005	0.500-13 UNC-2B	1.65	1.51	0.3125 x 0.3125 x 2.75
312	180-315	27.53	4.84	2.36	1.125 - 0.0005	0.375-16 UNC-2B	1.375	1.24	0.250 x 0.250 x 2.75
	355-11C	28.31	5.63	3.15	1.375 - 0.0005	0.500-13 UNC-2B	1.65	1.51	0.3125 x 0.3125 x 2.75

300UJ — Double & Triple Reduction Gear Drive/Hollow Shaft with Shrink Disc

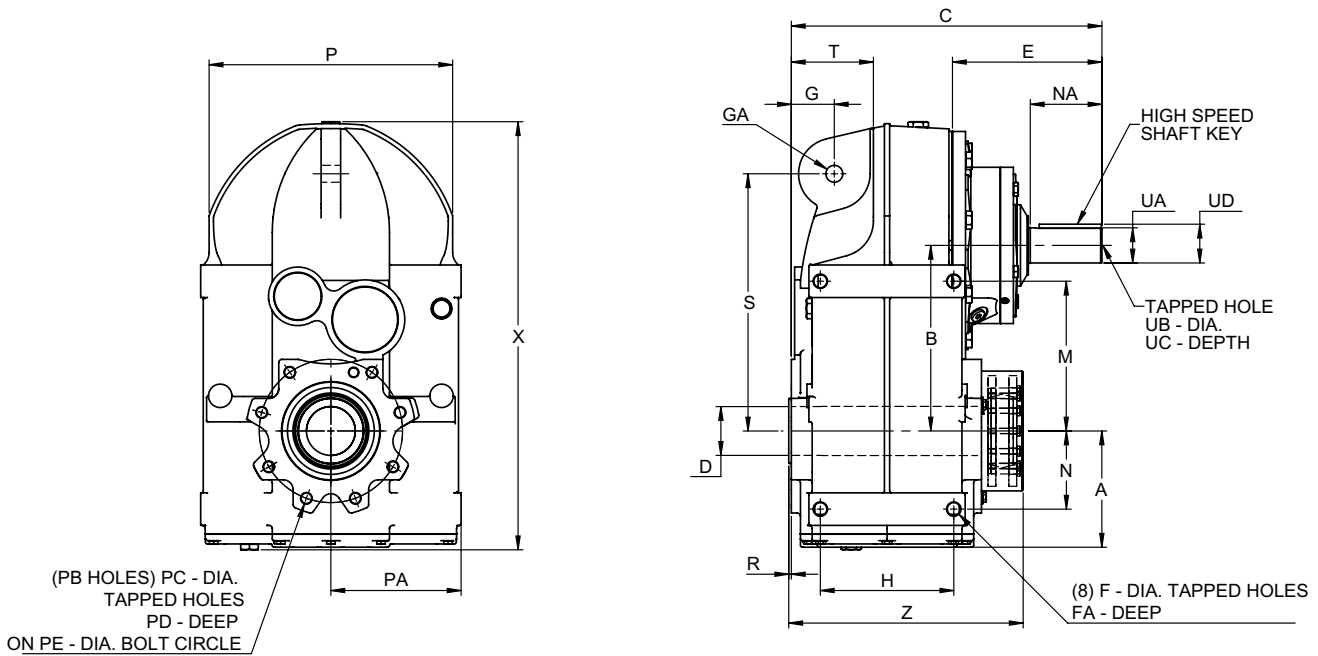

Type UJ Gearmotor — Hollow Shaft with Shrink Disc — 300UJAR (Dimensions—Inches)

Size*	A	B	D*	F	FA	G	GA	H	M	N	P	PA	PB	PC	PD	PE	R	S	T	X	Z
302	3.07	4.53	1.181	M8	0.51	1.20	0.55	3.03	3.31	1.22	5.51	3.25	0.20	M8	0.51	3.70	0.08	6.22	2.24	10.47	6.30
304	3.39	4.82	1.378	M10	0.83	1.18	0.55	3.66	4.02	1.69	5.51	3.54	0.28	M8	0.51	4.02	0.08	6.69	2.89	11.16	7.48
306	4.11	6.84	1.575	M12	0.71	1.54	0.55	4.41	5.12	2.36	7.40	4.17	0.24	M12	0.71	4.92	0.08	8.58	3.52	14.82	8.70
307	4.89	8.61	1.969	M16	1.02	1.87	0.87	5.51	6.69	2.76	10.63	5.31	0.31	M12	0.87	5.59	0.10	10.94	3.98	18.90	10.04
308	5.93	9.47	2.559	M16	1.02	2.34	0.87	6.50	8.27	3.94	11.38	6.50	0.24	M16	1.02	7.01	0.10	13.62	4.70	21.11	11.52
309	7.03	11.22	2.953	M20	1.10	2.60	1.02	8.07	9.06	4.72	14.72	7.87	0.31	M16	1.22	8.66	0.16	15.55	5.63	25.89	14.17
310	7.70	13.27	3.740	M24	1.42	2.83	1.02	8.66	10.83	4.92	15.98	8.86	0.31	M20	1.18	10.24	0.63	19.09	6.28	29.51	16.50
312	8.66	14.57	4.134	M30	1.77	3.74	1.30	10.63	15.67	5.59	17.64	10.43	0.43	M20	1.10	11.81	0.59	3.74	7.60	33.85	19.69

★ Refer to page 72 for shrink disc and driven shaft dimensions and recommendations.
 ■ See table on page 72 for tolerances.

SOLID INPUT — Double & Triple Reduction

Size	Ratio Range	Drive Size							
		C	E	NA	UA	UB	UC	UD	High Speed Shaft Key
302	3.5-90	8.41	4.35	1.57	0.625 - 0.0005	N/A	N/A	0.71	0.1875 x 0.1875 x 1.25
304	4.5-100	9.19	4.35	1.57	0.625 - 0.0005	N/A	N/A	0.71	0.1875 x 0.1875 x 1.25
306	3.1-5.6 & 8-14 & 63-100	10.47	4.84	2.36	1.125 - 0.0005	0.375-16 UNC-2B	1.38	1.24	0.250 x 0.250 x 2.75
	6.3-7.1 & 16-56	11.26	5.63	3.15	1.375 - 0.0005	0.500-13 UNC-2B	1.65	1.51	0.3125 x 0.3125 x 2.75
307	3.1-71 & 35-160	13.15	5.79	3.15	1.375 - 0.0005	0.500-13 UNC-2B	1.65	1.51	0.3125 x 0.3125 x 2.75
308	3.1-56 & 35-315	14.00	5.79	3.15	1.375 - 0.0005	0.500-13 UNC-2B	1.65	1.51	0.3125 x 0.3125 x 2.75
309	56-71 & 90-280	15.22	5.49	3.15	1.375 - 0.0005	0.500-13 UNC-2B	1.65	1.51	0.3125 x 0.3125 x 2.75
	3.1-50 & 40-80	18.78	9.06	4.33	2.125 - 0.0009	0.750-10 UNC-2B	2.13	2.35	0.500 x 0.500 x 3.75
310	90-280	16.44	5.49	3.15	1.375 - 0.0005	0.500-13 UNC-2B	1.65	1.51	0.3125 x 0.3125 x 2.75
	3.1-56 & 40-80	20.00	9.06	4.33	2.125 - 0.0009	0.750-10 UNC-2B	2.13	2.35	0.500 x 0.500 x 3.75
312	8-125	23.86	9.06	4.33	2.125 - 0.0009	0.750-10 UNC-2B	2.13	2.35	0.500 x 0.500 x 3.75

300UJ — Quadruple & Quintuple Reduction Gear Drive/Hollow Shaft with Shrink Disc

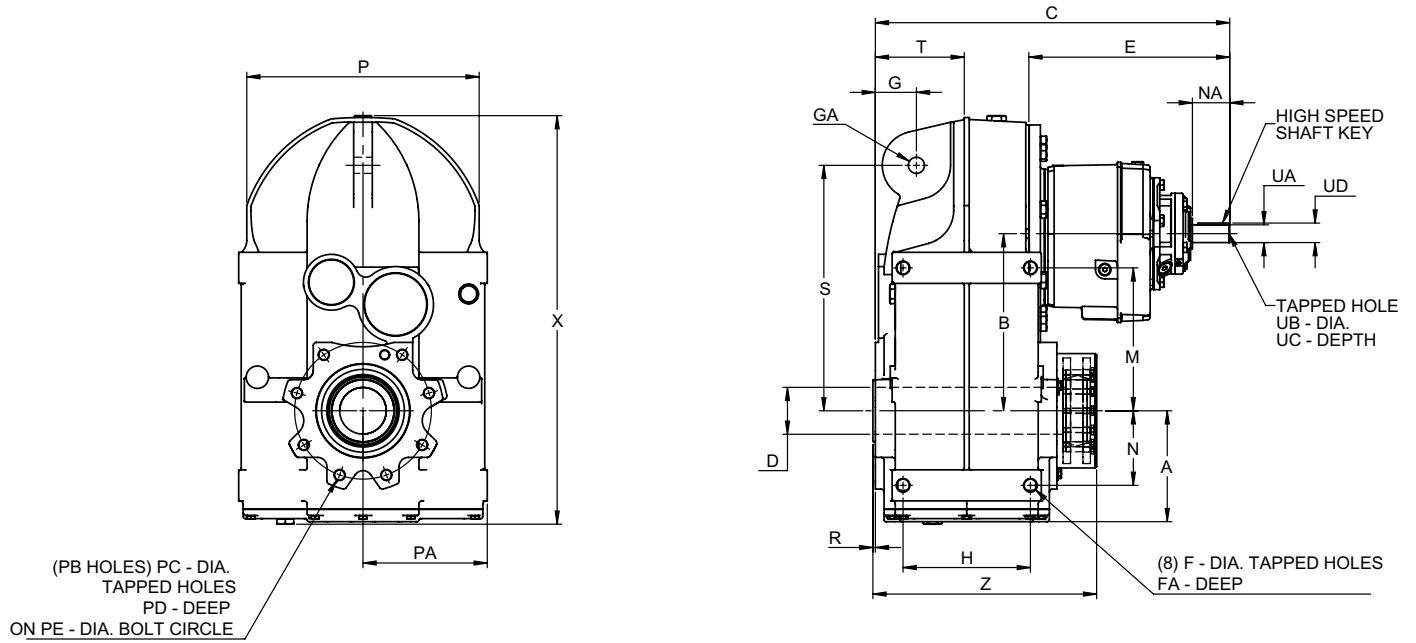

Type UJ Gearmotor — Hollow Shaft with Shrink Disc — 300UJAR (Dimensions—Inches)

Size*	A	B	D*	F	FA	G	GA	H	M	N	P	PA	PB	PC	PD	PE	R	S	T	X	Z
302	3.07	4.53	1.181	M8	0.51	1.20	0.55	3.03	3.31	1.22	5.51	3.25	0.20	M8	0.51	3.70	0.08	6.22	2.24	10.47	6.30
304	3.39	4.82	1.378	M10	0.83	1.18	0.55	3.66	4.02	1.69	5.51	3.54	0.28	M8	0.51	4.02	0.08	6.69	2.89	11.16	7.48
306	4.11	6.84	1.575	M12	0.71	1.54	0.55	4.41	5.12	2.36	7.40	4.17	0.24	M12	0.71	4.92	0.08	8.58	3.52	14.82	8.70
307	4.89	8.61	1.969	M16	1.02	1.87	0.87	5.51	6.69	2.76	10.63	5.31	0.31	M12	0.87	5.59	0.10	10.94	3.98	18.90	10.04
308	5.93	9.47	2.559	M16	1.02	2.34	0.87	6.50	8.27	3.94	11.38	6.50	0.24	M16	1.02	7.01	0.10	13.62	4.70	21.11	11.52
309	7.03	11.22	2.953	M20	1.10	2.60	1.02	8.07	9.06	4.72	14.72	7.87	0.31	M16	1.22	8.66	0.16	15.55	5.63	25.89	14.17
310	7.70	13.27	3.740	M24	1.42	2.83	1.02	8.66	10.83	4.92	15.98	8.86	0.31	M20	1.18	10.24	0.63	19.09	6.28	29.51	16.50
312	8.66	14.57	4.134	M30	1.77	3.74	1.30	10.63	15.67	5.59	17.64	10.43	0.43	M20	1.10	11.81	0.59	3.74	7.60	33.85	19.69

★ Refer to page 72 for shrink disc and driven shaft dimensions and recommendations.
 ■ See table on page 72 for tolerances.

SOLID INPUT — Quadruple & Quintuple Reduction

Size	Ratio Range	Drive Size							
		C	E	NA	UA	UB	UC	UD	High Speed Shaft Key
302	99-800	15.06	4.35	1.57	0.625 - 0.0005	N/A	N/A	0.71	0.1875 x 0.1875 x 1.25
304	100-900	15.87	4.35	1.57	0.625 - 0.0005	N/A	N/A	0.71	0.1875 x 0.1875 x 1.25
306	100-10C	16.30	4.35	1.57	0.625 - 0.0005	N/A	N/A	0.71	0.1875 x 0.1875 x 1.25
307	180-11C	17.56	4.35	1.57	0.625 - 0.0005	N/A	N/A	0.71	0.1875 x 0.1875 x 1.25
308	280-11C	18.41	4.35	1.57	0.625 - 0.0005	N/A	N/A	0.71	0.1875 x 0.1875 x 1.25
309	140-200 & 900-10C	22.45	4.84	2.36	1.125 - 0.0005	0.375-16 UNC-2B	1.375	1.24	0.250 x 0.250 x 2.75
	224-800	23.24	5.63	3.15	1.375 - 0.0005	0.500-13 UNC-2B	1.65	1.51	0.3125 x 0.3125 x 2.75
310	125-224 & 10C-11C	23.67	4.84	2.36	1.125 - 0.0005	0.375-16 UNC-2B	1.375	1.24	0.250 x 0.250 x 2.75
	250-900	24.46	5.63	3.15	1.375 - 0.0005	0.500-13 UNC-2B	1.65	1.51	0.3125 x 0.3125 x 2.75
312	180-315	27.53	4.84	2.36	1.125 - 0.0005	0.375-16 UNC-2B	1.375	1.24	0.250 x 0.250 x 2.75
	355-11C	28.31	5.63	3.15	1.375 - 0.0005	0.500-13 UNC-2B	1.65	1.51	0.3125 x 0.3125 x 2.75

300UJ — Screw Conveyor Gearmotor and Gear Drive

Screw Conveyor Gearmotor with Seal Housing and Driveshaft

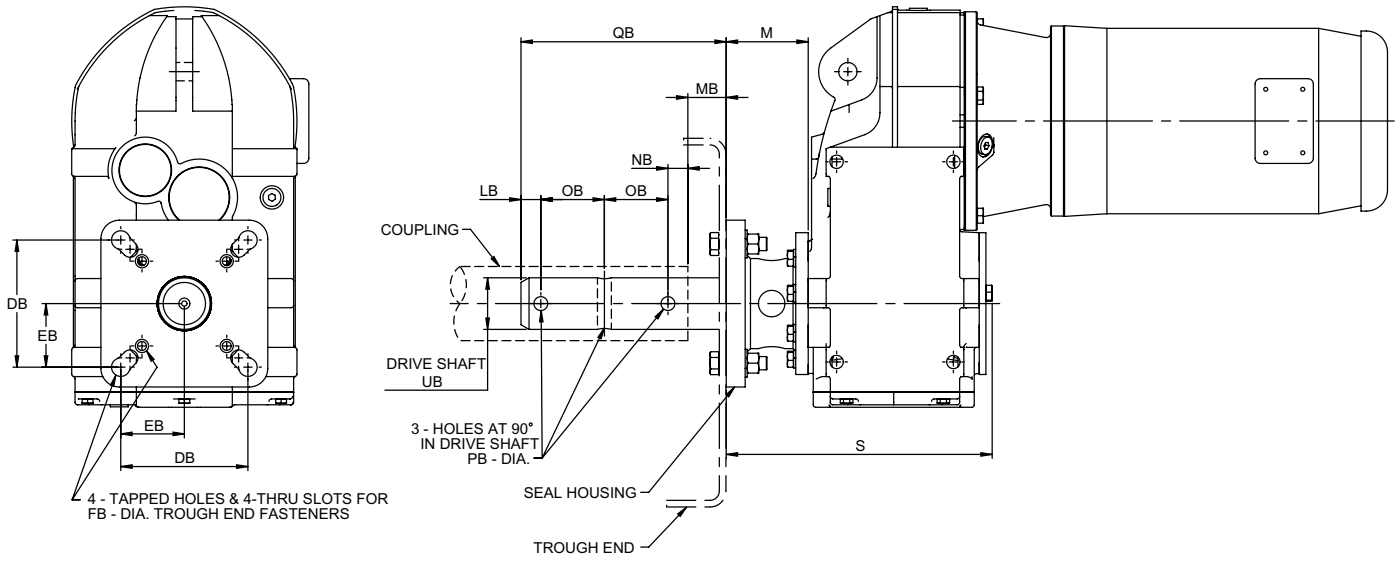

All other drive dimensions may be obtained from the standard drive dimension pages.

Consult standard drive selection tables for horsepower and torque ratings.

Screw Conveyor Gear Drive with Seal Housing and Driveshaft

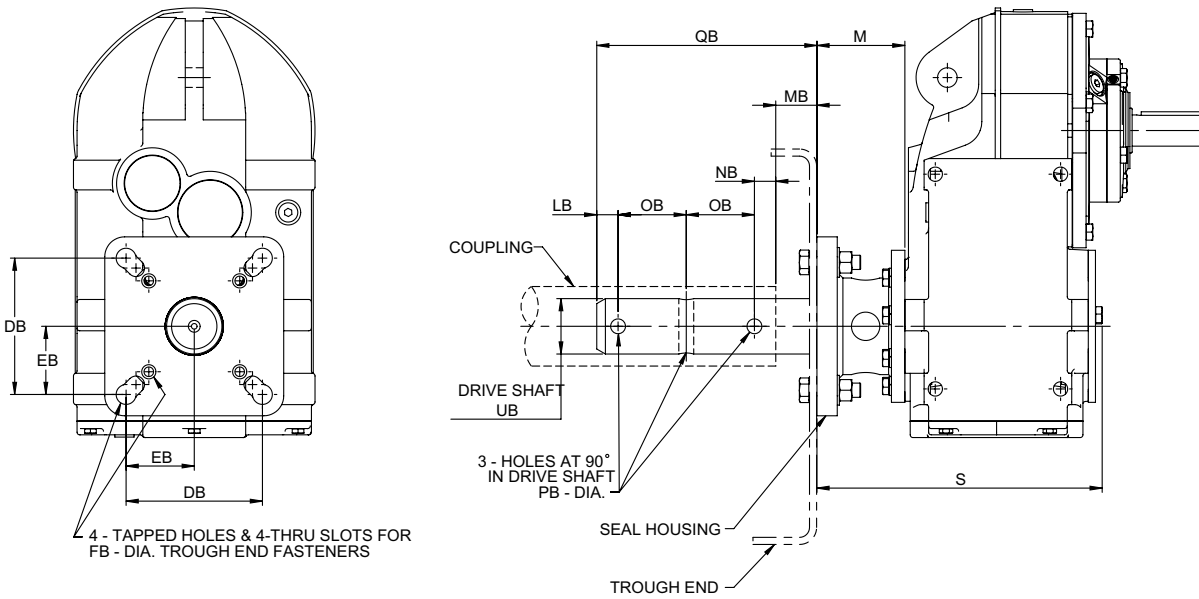

300UJ — Screw Conveyor Gearmotor and Gear Drive

Screw Conveyor Component Dimensions (in)

SIZE	Screw Conveyor Components								M	S	DB	EB	FB	LB	MB	NB	OB	PB	QB	UB [‡]
	Cplg Dia	Screw Dia	Max Torque (lb _r -in) [●]	Driveshaft Kit P/N*	Wt (lb)	Seal Housing Kit Part No.	Wt (lb)													
302	1.500	6,9	2036	10606082	8	10604536	17	3.87	8.96	4.000	2.000	0.500	0.875	1.250	0.875	3.000	0.531	9.000	1.500	
	2.000	9,12	2036	10604781	12	10604536	17	3.87	8.96	5.125	2.562	0.625	0.875	1.250	0.875	3.000	0.656	9.000	2.000	
	2.437	12,14	2036	10604782	17	10604536	17	3.87	9.23	5.625	2.812	0.625	0.938	1.812	0.938	3.000	0.656	9.688	2.437	
304	1.500	6,9	3894	10606052	9	10604538	17	3.87	10.14	4.000	2.000	0.500	0.875	1.250	0.875	3.000	0.531	9.000	1.500	
	2.000	9,12	3894	10604783	13	10604538	17	3.87	10.14	5.125	2.562	0.625	0.875	1.250	0.875	3.000	0.656	9.000	2.000	
	2.437	12,14	3894	10604787	18	10604538	17	3.87	10.41	5.625	2.812	0.625	0.938	1.812	0.938	3.000	0.656	9.688	2.437	
306	1.500	6,9	5191	10606211	10	10604539	20	3.87	11.41	4.000	2.000	0.500	0.875	1.250	0.875	3.000	0.531	9.000	1.500	
	2.000	9,12	7157	10606125	14	10604539	20	3.87	11.41	5.125	2.562	0.625	0.875	1.250	0.875	3.000	0.656	9.000	2.000	
	2.437	12,14	7418	10606141	18	10604539	20	3.87	11.41	5.625	2.812	0.625	0.938	1.812	0.938	3.000	0.656	9.688	2.437	
307	1.500	6,9	4171	10611367	15	10604540	21	3.87	12.55	4.000	2.000	0.500	0.875	1.250	0.875	3.000	0.531	9.000	1.500	
	2.000	9,12	10200	10611434	20	10604540	21	3.87	12.55	5.125	2.562	0.625	0.875	1.250	0.875	3.000	0.656	9.000	2.000	
	2.437	12,14	15045	10611436	24	10604540	21	3.87	12.55	5.625	2.812	0.625	0.938	1.812	0.938	3.000	0.656	9.688	2.437	
308	1.500	9	5191	10611514	20	10604541	27	4.04	14.00	4.000	2.000	0.500	0.875	1.250	0.875	3.000	0.531	9.000	1.500	
	2.000	9,12	12240	10611555	25	10604541	27	4.04	14.00	5.125	2.562	0.625	0.875	1.250	0.875	3.000	0.656	9.000	2.000	
	2.437	12,14	22142	10611628	30	10604541	27	4.04	14.00	5.625	2.812	0.625	0.938	1.812	0.938	3.000	0.656	9.688	2.437	
309	1.500	9	25665	10611629	37	10604541	27	4.04	14.00	6.000	3.000	0.750	1.000	1.875	1.000	3.000	0.781	9.875	3.000	
	3.437	18-24	25665	10611630	51	10604541	27	4.04	14.00	6.750	3.375	0.750	1.250	2.375	1.500	4.000	0.906	13.125	3.437	
	2.000	9,12	12240	10611674	37	10604542	36	4.62	16.59	5.125	2.562	0.625	0.875	1.250	0.875	3.000	0.656	9.000	2.000	
310	2.437	12,14	19731	10611775	41	10604542	36	4.62	16.59	5.625	2.812	0.625	0.938	1.812	0.938	3.000	0.656	9.688	2.437	
	3.000	12-20	45720	10611776	49	10604542	36	4.62	16.59	6.000	3.000	0.750	1.000	1.875	1.000	3.000	0.781	9.875	3.000	
	3.437	18-24	45720	10611777	63	10604542	36	4.62	16.59	6.750	3.375	0.750	1.250	2.375	1.500	4.000	0.906	13.125	3.437	
311	2.437	12,14	19731	10611790	57	10604543	53	5.00	18.09	5.625	2.812	0.625	0.938	1.812	0.938	3.000	0.656	9.688	2.437	
	3.000	12-20	41709	10611863	65	10604543	53	5.00	18.09	6.000	3.000	0.750	1.000	1.875	1.000	3.000	0.781	9.875	3.000	
	3.437	18-24	66829	10611864	79	10604543	53	5.00	18.09	6.750	3.375	0.750	1.250	2.375	1.500	4.000	0.906	13.125	3.437	
312	3.000	12-20	37167	10611907	85	10604544	70	5.00	21.14	6.000	3.000	0.750	1.000	1.875	1.000	3.000	0.781	9.875	3.000	
	3.437	18-24	66829	10611910	99	10604544	70	5.00	21.14	6.750	3.375	0.750	1.250	2.375	1.500	4.000	0.906	13.125	3.437	

316 Stainless Steel Driveshafts (in)

SIZE	Cplg Dia	Screw Dia	Max Torque (lb _r -in) [▲]	Driveshaft Kit Part No. ■	Wt (lb)
302	1.500	6,9	2036	10604784	8
	2.000	9,12	2036	10604785	12
	2.437	12,14	2036	10604786	17
304	1.500	6,9	2688	10606105	9
	2.000	9,12	2959	10606121	13
	2.437	12,14	2959	10606124	18
306	1.500	6,9	2688	10611143	10
	2.000	9,12	3844	10611191	14
	2.437	12,14	3841	10611192	18
307	1.500	6,9	2688	10611441	15
	2.000	9,12	6573	10611443	20
	2.437	12,14	9111	10611445	24
310	1.500	6,9	2688	10611441	15
	2.000	9,12	6573	10611443	20
	2.437	12,14	9111	10611445	24
312	1.500	6,9	2688	10611441	15
	2.000	9,12	6573	10611443	20
	2.437	12,14	9111	10611445	24

SIZE	Cplg Dia	Screw Dia	Max Torque (lb _r -in) [▲]	Driveshaft Kit Part No. ■	Wt (lb)
308	1.500	9	2688	10611631	20
	2.000	9,12	6573	10611632	25
	2.437	12,14	12715	10611633	30
309	3.000	12-20	15251	10611634	37
	3.437	18-24	15251	10611635	51
	2.000	9,12	6573	10611778	37
310	2.437	12,14	12715	10611779	41
	3.000	12-20	23676	10611780	49
	3.437	18-24	23676	10611781	63
311	2.437	12,14	12715	10611865	57
	3.000	12-20	23952	10611876	65
	3.437	18-24	35890	10611877	79
312	3.000	12-20	23952	10611911	85
	3.437	18-24	35890	10611912	99

Trough End Seal Sealing Options

SIZE	Waste Packing Part Number ♦	Nitrile Seal Part Number	Viton® Seal Part Number
302	10499841	10606081	10603218
304	10499841	10606083	10603231
306	10499841	10606083	10603231
307	10499841	10611510	10603338
308	10499841	10611537	10603340
309	10499841	10611671	10604565
310	10499841	10611788	10604696
312	10499841	10611788	10604696

- Check drive shaft torque & bending capacity and coupling bolt shear & bending stresses against load to be transmitted.
- ★ Hexagon head screws with UNC thread are furnished by Rexnord for mounting the gear drive to the trough end. Screws are included with the drive shaft kit.
- ‡ Shaft diameters under 3.000" are held to limits of +0.000/-0.002". Shaft diameters 3.000" and over are held to limits of +0.000/-0.003".
- ▲ Check torque & bending capacity of driven shaft and coupling bolt shear against load.
Mechanical properties of stainless steel differ from those of carbon steel.
- Furnished with stainless steel trough end-to-seal housing fasteners.
- ♦ Wastepacking material comes standard with seal housing kit.

300UJ — Hollow Low Speed Shaft Dimensions and Recommendations

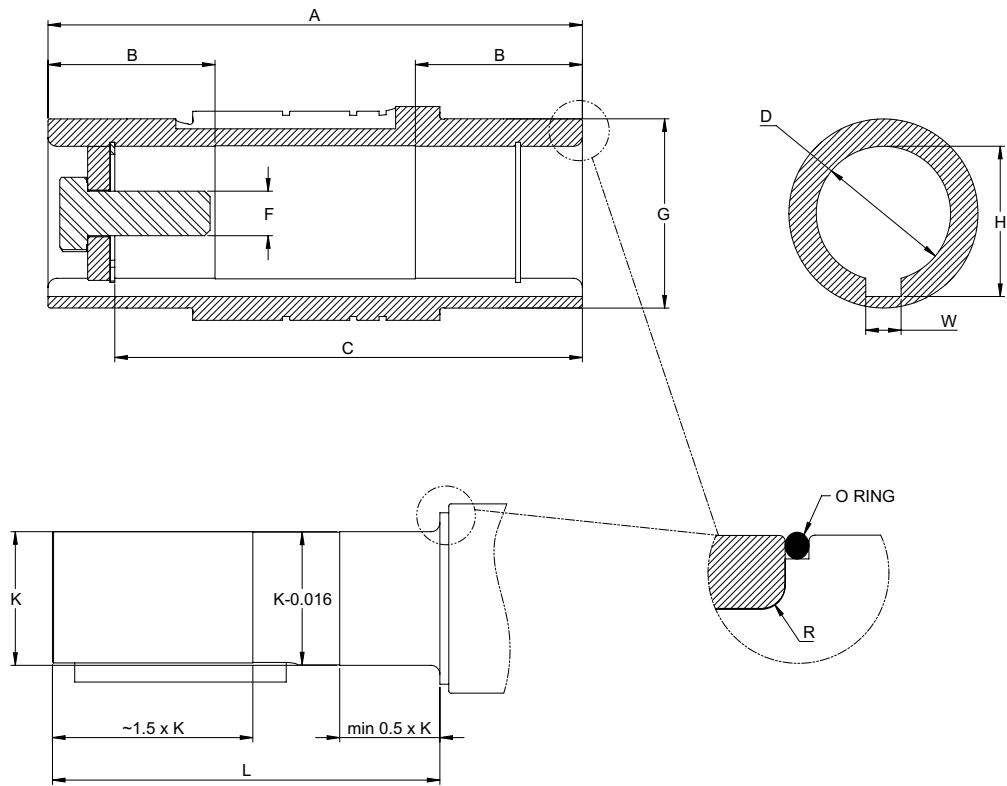

Straight Hollow Shaft — 300UJAQ (Dimensions—Inch)

Size	A	B	C	D	F	G	H	K	L	R	W
302	4.72	1.77	4.13	1.000 +0.0008, -0	0.375-16UNC	1.77	1.12	1.000 +0, -0.0005	3.23	0.12	0.25
				1.250 +0.0010, -0			1.37	1.250 +0, -0.0006			
304	5.91	1.97	5.20	1.250 +0.0010, -0	0.375-16UNC	1.96	1.37	1.250 +0, -0.0006	4.29	0.12	0.25
				1.375 +0.0010, -0			1.52	1.375 +0, -0.0006			0.31
306	7.09	2.36	6.14	1.500 +0.0010, -0	0.625-11UNC	2.16	1.67	1.500 +0, -0.0006	5.00	0.12	0.38
307	8.27	2.56	7.20	2.000 +0.0012, -0	0.625-11UNC	2.75	2.23	2.000 +0, -0.0007	6.06	0.16	0.50
308	9.45	2.95	8.27	2.375 +0.0012, -0	0.750-10UNC	3.34	2.66	2.375 +0, -0.0007	6.85	0.16	0.63
309	11.81	2.95	10.63	2.750 +0.0012, -0	0.750-10UNC	3.93	3.04	2.750 +0, -0.0007	9.21	0.16	0.63
310	13.78	3.15	12.32	3.250 +0.0014, -0	0.750-10UNC	4.72	3.59	3.250 +0, -0.0009	10.98	0.16	0.75
312	16.14	3.94	14.69	4.000 +0.0014, -0	1.00-8UNC	5.51	4.45	4.000 +0, -0.0009	12.99	0.16	1.00

Indicates alternate LS shaft bore.

300UJ — Customer Shaft Recommendations: Dimensions for Largest for TA Taper Bore Bushings

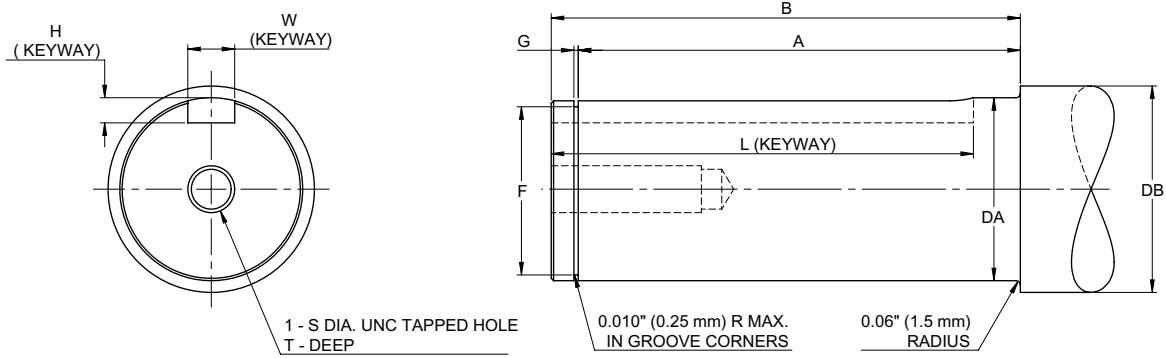

Dimensions for Largest Bore Bushing (Dimensions—Inch) ▲

Size	Thrust Plate Kit Part No. ■	A ±0.010	B ±0.030	DA ★	DB Min.	Retaining Ring ●				Keyway ‡			S	T Min.
						Groove		Spir O Lox		W	H	L Min.		
						F	G	Mfg. No.	Max O.D.					
306	10604477	4.780	5.000	1.4375	1.750	1.295	0.056	RSN-137	1.500	0.375	0.1875	3.563	0.500-13	2.00
						1.287	0.060							
307	10604479	5.330	5.500	1.9375	2.250	1.735	0.068	RST-181	2.000	0.500	0.2500	4.000	0.500-13	2.00
						1.725	0.072							
308	10604480	5.890	6.250	2.4375	2.750	2.290	0.056	RS-236	2.500	0.625	0.3125	5.625	0.625-11	2.00
						2.278	0.060							
309	10604481	5.890	6.250	2.4375	2.750	2.290	0.056	RS-236	2.500	0.625	0.3125	5.625	0.625-11	2.00
						2.278	0.060							
310	10604482	7.170	7.500	3.4375	3.750	3.172	0.103	RSN-334	3.625	0.875	0.4375	6.750	1.000-8	2.50
						3.160	0.108							
312	10604483	7.700	8.000	3.9375	4.250	3.701	0.120	RST-387	4.125	1.000	0.5000	7.062	1.000-8	2.50
						3.690	0.125							

▲ For metric drive shafts or bushing bores smaller than the maximum provide the retaining ring groove per manufacturers' recommendations, keyway appropriate for the shaft diameter, and DB minimum of 0.300" larger than the bushing bore to provide adequate backing.

■ Kit consists of: thrust plate, thrust plate fastener, and hollow shaft retaining ring.

★ Shaft diameter tolerances are per AGMA as follows: to 1.50" +0.000/-0.004"; over 1.50" to & including 2.50" = +0.000/-0.005"; over 2.50" to & including 4.00" = +0.000/-0.006". Metric drive shafts are to be based on h10 tolerances.

● Smalley retaining rings may be used instead of Spir O Lox by substituting WS for RS, WST for RST, or WSM for RSN.

‡ Inch keyway width tolerances are as follows: over 0.312" to & including 0.500" = +0.0025/-0.0000"; over 0.500" to & including 1.000" = +0.0030/-0.0000". Metric keyway widths are based on class N9 tolerances. Inch keyway depth tolerance is +0.010/-0.000". Refer to ISO 773 or DIN 6885 sheet 1 for metric keyway depth tolerances.

300UJ — Shrink Disc Shaft Dimensions and Recommendations

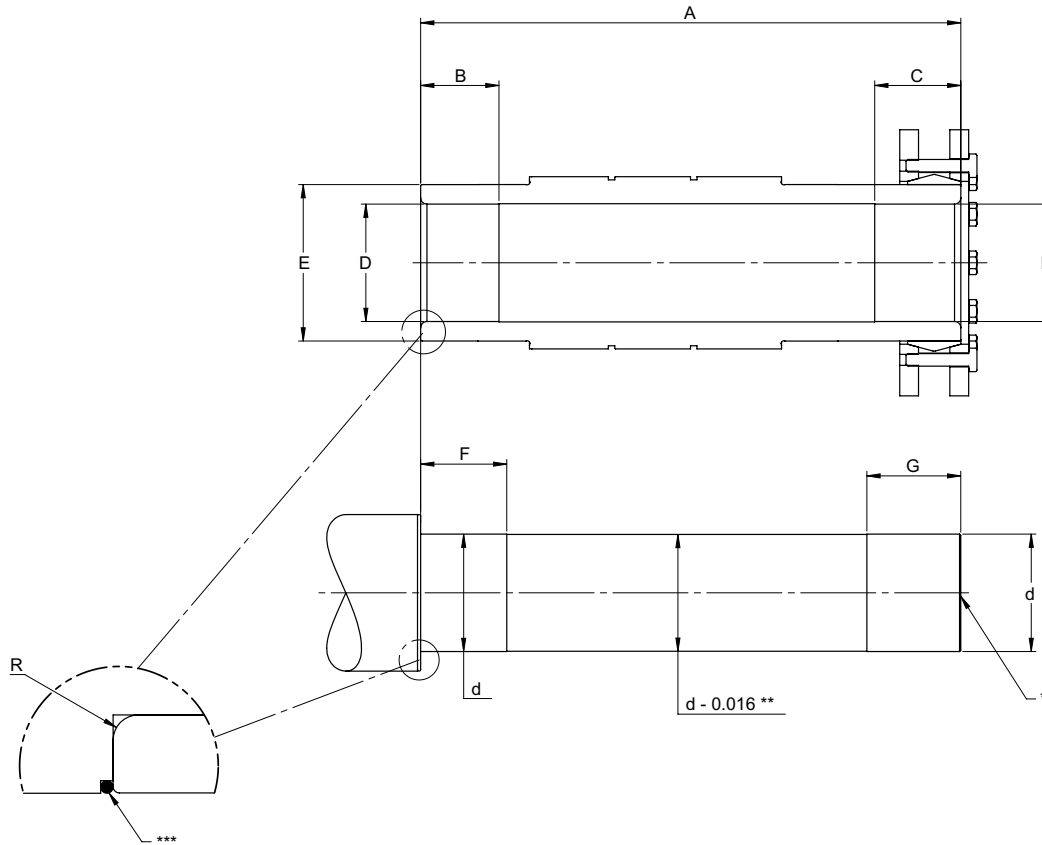

Shrink Disc Shaft Dimensions (Dimensions–Inch)

Size	A	B	C	D	Tol.	d	Tol.	E	F	G	R
302	5.75	0.79	1.22	1.181	+0.0008	1.181	+0.000	1.77	0.98	1.42	0.12
					-0.0000		-0.002				
304	6.97	0.79	1.26	1.378	+0.0010	1.378	+0.000	1.97	0.98	1.46	0.12
					-0.0000		-0.003				
306	8.19	0.79	1.50	1.575	+0.0010	1.575	+0.000	2.17	0.98	1.69	0.12
					-0.0000		-0.003				
307	9.49	0.98	1.42	1.969	+0.0010	1.969	+0.000	2.76	1.18	1.61	0.16
					-0.0000		-0.003				
308	11.06	1.57	1.61	2.559	+0.0012	2.559	+0.000	3.35	1.18	1.81	0.16
					-0.0000		-0.003				
309	13.58	1.97	2.17	2.953	+0.0012	2.953	+0.000	3.94	2.17	2.36	0.16
					-0.0000		-0.003				
310	15.94	2.36	2.56	3.740	+0.0014	3.740	+0.000	4.72	2.76	2.95	0.16
					-0.0000		-0.004				
312	19.09	2.76	3.35	4.134	+0.0014	4.134	+0.000	5.51	3.15	3.74	0.16
					-0.0000		-0.004				

300UJ — B5 Output Flange

B5 OUTPUT FLANGE - 4 HOLE
SIZES 302, 304, 306, 307, 308

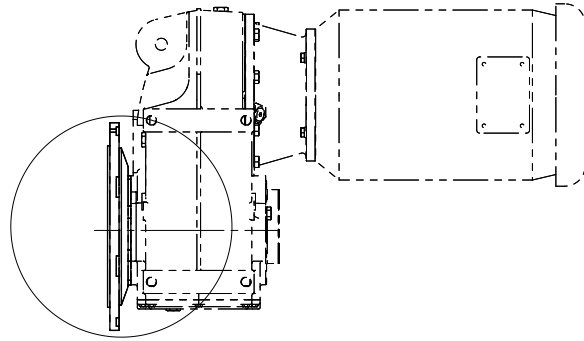
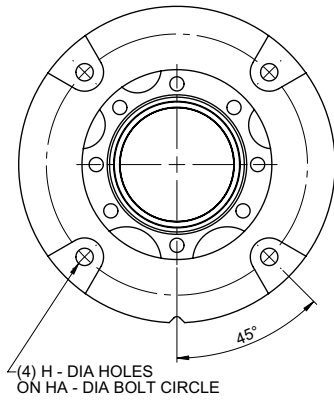

B5 OUTPUT FLANGE - 8 HOLE
SIZES 309, 310, 312

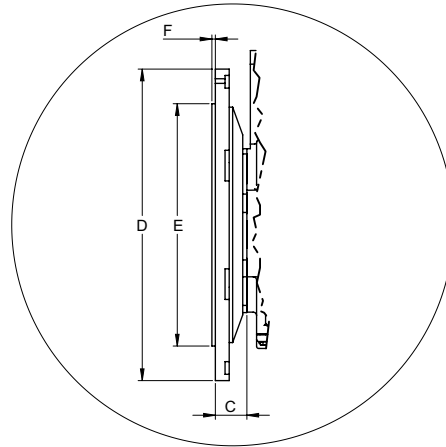
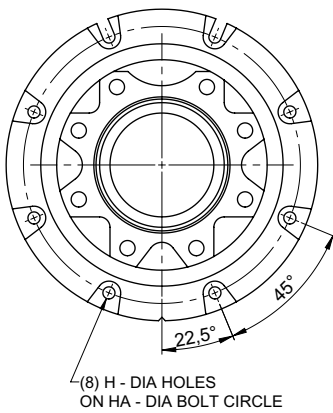

B5 Output Flange — 300UJF (Dimensions—Inch)

Size	C	D	E	F	H	HA
302	1.02	6.30	4.33	0.14	0.35	5.12
304	1.06	7.87	5.12	0.14	0.43	6.50
306	0.98	9.84	7.09	0.16	0.53	8.46
307	1.56	11.81	9.06	0.16	0.53	10.43
308	1.28	13.78	9.84	0.20	0.71	11.81
309	1.79	17.72	13.78	0.20	0.69	15.75
310	2.24	17.72	13.78	0.20	0.69	15.75
312	2.60	21.65	17.72	0.20	0.69	19.69

300UJ — B14 Output Flange

B14 OUTPUT FLANGE - SIZE 302

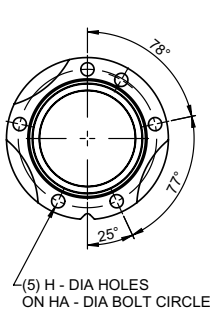

B14 OUTPUT FLANGE - SIZE 304

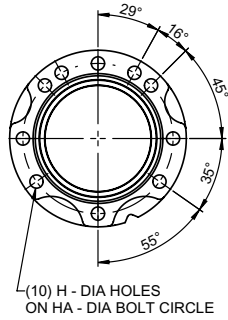

B14 OUTPUT FLANGE - SIZE 306

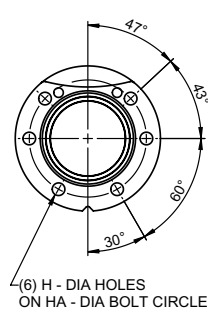

B14 OUTPUT FLANGE - SIZE 307

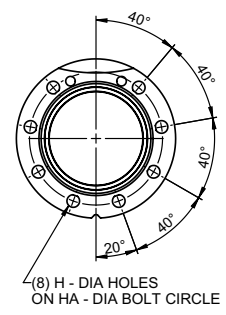

B14 OUTPUT FLANGE - SIZE 308

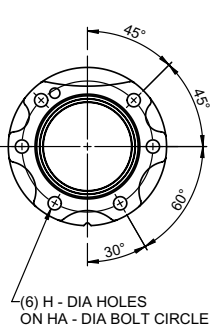

B14 OUTPUT FLANGE - SIZE 309

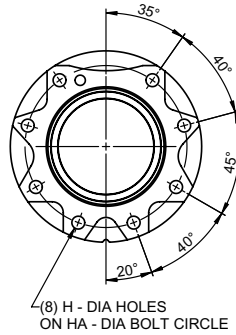

B14 OUTPUT FLANGE - SIZE 310

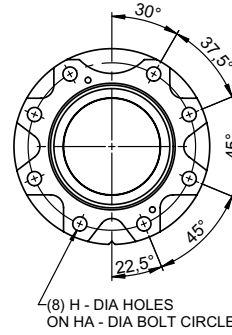

B14 OUTPUT FLANGE - SIZE 312

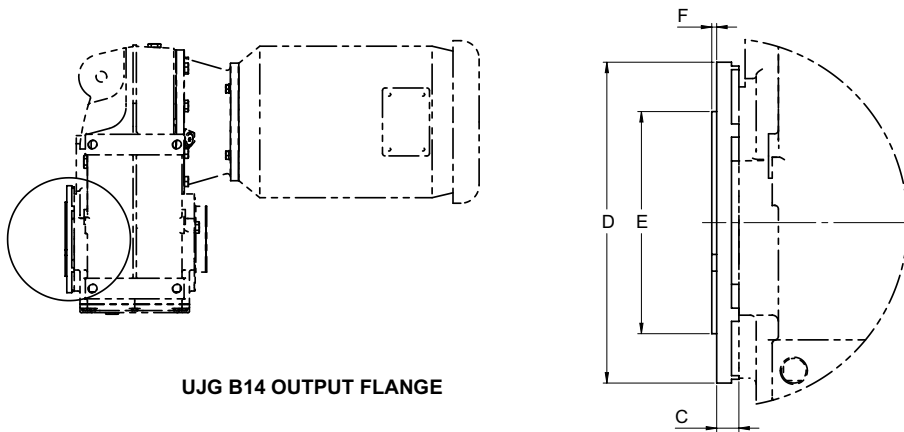
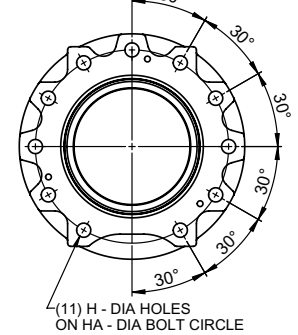

B14 Output Flange — 300UJG (Dimensions—Inch)

Size	C	D	E	F	H	HA
302	0.43	4.33	3.15	0.12	0.35	3.70
304	0.39	4.72	3.15	0.12	0.35	4.02
306	0.41	6.10	4.13	0.14	0.53	4.92
307	0.49	6.69	4.92	0.14	0.53	5.59
308	0.53	8.46	6.10	0.16	0.71	7.01
309	0.71	10.24	7.09	0.16	0.69	8.66
310	0.31	11.97	8.27	0.16	0.87	10.24
312	0.59	13.78	9.84	0.20	0.87	11.81

300UJ — Torque Arm

Torque Arm / Dimensions—Inch

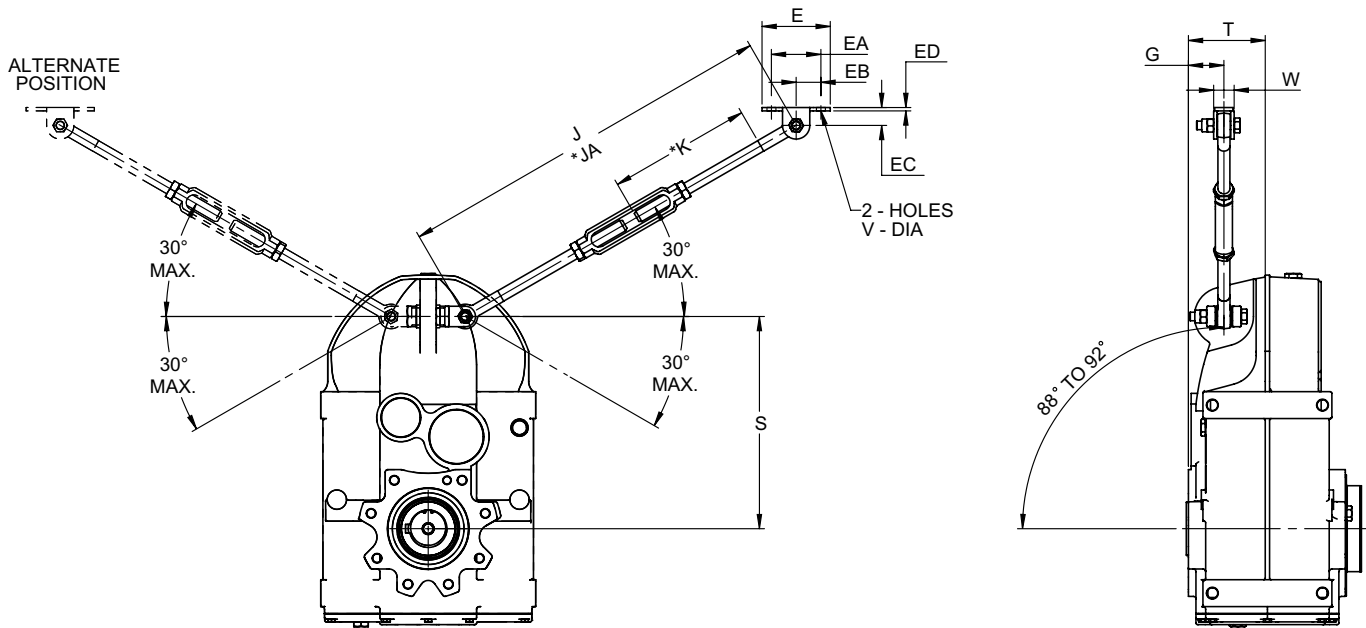

*EACH ROD END MAY BE CUT OFF TO MINIMUM "K" LENGTH.
 "JA" IS TOTAL LENGTH WITH CUT OFF ROD ENDS.

Dimensions (in)

Size	E	EA	EB	EC	ED	G	J		JA		K		S	T	V	W	Max Reaction Loads* (lbs)	Part Number
							Min.	Max.	Min.	Max.	Std.	Min.						
302	3.56	2.50	1.25	1.00	0.25	1.20	21.00	27.00	12.50	18.50	8.50	4.12	6.22	2.24	0.41	1.06	1200	10603648
304	3.56	2.50	1.25	1.00	0.25	1.18	21.00	27.00	12.50	18.50	8.50	4.12	6.69	2.89	0.41	1.06	1700	10603648
306	3.56	2.50	1.25	1.00	0.25	1.54	21.00	27.00	12.50	18.50	8.50	4.12	8.58	3.52	0.41	1.06	2800	10603650
307	4.25	3.00	1.50	1.12	0.25	1.87	24.00	30.00	15.00	21.00	9.00	4.38	10.94	3.98	0.53	1.23	4100	10603651
308	4.25	3.00	1.50	1.12	0.25	2.34	24.00	30.00	15.00	21.00	9.00	4.38	13.62	4.70	0.53	1.23	5700	10603652
309	5.00	3.62	1.81	1.31	0.25	2.60	27.00	33.00	15.50	21.50	10.50	4.62	15.55	5.63	0.66	1.37	9300	10287279
310	8.69	6.50	3.25	2.63	1.00	2.83	29.50	35.25	14.50	20.50	12.75	5.25	19.09	6.28	0.88	3.25	12100	10603654
312	9.69	7.00	3.50	3.13	1.13	3.74	29.50	35.25	13.50	19.25	12.75	4.75	21.65	7.60	1.13	3.94	15890	10603655

* Load includes torque at startup (100% overload) with torque arm at maximum angle.

300UJ — Rubber Bushing Kit

Rubber Bushing Kit / Dimensions—Inch

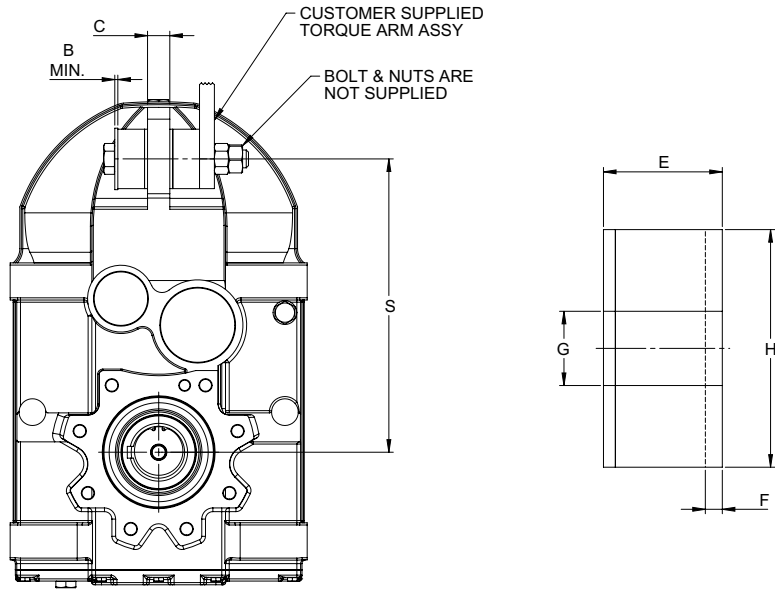

Dimensions (in)

Size	B	C	E	F	G + 0.02	H	S	Part Number †
302	0.20	0.47	0.79	0.06	0.49	1.57	6.22	10603277
304	0.20	0.47	0.79	0.06	0.49	1.57	6.69	10603277
306	0.20	0.63	0.79	0.10	0.49	1.57	8.58	10603278
307	0.39	0.79	1.18	0.13	0.83	2.36	10.94	10603358
308	0.39	1.02	1.18	0.17	0.83	2.36	13.62	10603358
309	0.47	1.18	1.57	0.16	0.98	3.15	15.55	10603359
310	0.47	1.42	1.57	0.25	0.98	3.15	19.09	10603359
312	0.59	1.57	2.36	0.41	1.26	3.94	21.65	10603360

† Each kit comes with two rubber bushings.

300UJ — WR²

300UJ WR² (lb-in²) Referred to Reducer High Speed Shaft

Nominal Ratios	Unit Size							
	302UJ	304UJ	306UJ	307UJ	308UJ	309UJ	310UJ	312UJ
DOUBLE REDUCTION								
3.1	—	—	—	—	—	—	—	—
3.5	—	—	—	—	—	—	—	—
4.0	—	—	—	—	—	—	—	—
4.5	—	—	—	—	—	—	—	—
5.0	—	—	—	—	—	—	—	—
5.6	0.290	0.752	2.77	6.32	6.32	—	—	—
6.3	0.263	0.683	2.49	5.64	5.64	33.8	68.3	109
7.1	0.236	0.615	2.19	5.13	5.13	29.0	58.1	92.9
8.0	0.202	0.547	1.98	4.27	4.27	25.3	49.5	79.3
9.0	0.188	0.461	1.81	3.93	3.93	21.9	44.4	71.8
10.	0.167	0.410	1.61	3.59	3.59	19.8	37.6	59.8
11.	0.154	0.376	1.50	3.04	3.04	16.7	34.2	43.6
12.	0.147	0.318	1.37	2.80	2.80	15.4	30.4	38.4
14.	0.137	0.290	1.26	2.43	2.43	13.7	27.0	29.9
16.	0.123	0.263	1.20	2.19	2.19	11.6	21.9	—
18.	0.113	0.236	1.09	1.98	1.98	10.3	19.1	—
20.	0.106	0.212	1.03	1.81	1.81	9.40	16.4	—
22.	0.099	0.188	0.957	1.61	1.61	8.88	15.4	—
25.	0.094	0.164	0.888	1.44	4.78	7.86	13.0	—
28.	0.091	0.154	0.871	1.26	4.44	7.52	12.0	—
31.	0.087	0.140	0.803	1.20	3.93	6.49	9.91	—
35.	0.084	0.126	0.786	1.06	3.76	—	—	—
40.	0.079	0.109	0.752	0.923	3.42	—	—	—
45.	0.075	0.096	0.735	0.786	3.08	—	—	—
50.	0.072	0.082	0.701	0.683	2.90	—	—	—
63.	0.060	0.123	0.581	0.581	—	—	—	—
71.	0.055	0.111	0.547	0.513	—	—	—	—
80.	0.053	0.101	0.504	—	—	—	—	—
90.	0.049	0.089	0.470	—	—	—	—	—
100	0.047	0.080	0.444	—	—	—	—	—
TRIPLE REDUCTION								
35.	—	—	—	3.49	11.1	—	—	37.6
40.	—	—	—	3.28	10.3	11.6	13.0	30.8
45.	—	—	—	2.87	9.06	10.1	11.3	25.3
50.	—	—	—	2.63	8.20	12.6	10.3	21.9
56.	—	—	—	2.29	7.52	8.54	9.40	17.4
63.	—	—	—	2.08	6.49	7.52	8.20	14.0
71.	—	—	—	1.91	5.98	6.83	7.35	11.3
80.	—	—	—	1.74	5.30	6.32	6.66	10.1
90.	—	—	—	1.54	5.13	5.98	6.32	8.54
100	—	—	—	1.40	4.61	5.47	5.64	7.01
112	—	—	—	1.23	4.44	5.30	5.47	5.98
125	—	—	—	1.20	3.93	4.78	4.95	4.78
140	—	—	—	1.06	3.76	4.61	4.61	4.10
160	—	—	—	0.991	3.35	4.27	4.27	3.08
180	—	—	—	0.923	—	—	—	2.60

300UJ — Approximate Shipping Weights

300UJ Offset Parallel Drive Weights†

Size	C-Flange Or Solid Input Shaft	Double & Triple Reduction		Quadruple & Quintuple Reduction	
		Weight [lb]	Weight [kg]	Weight [lb]	Weight [kg]
302	C-Flange	40	18	64	29
302	Solid Input	44	20	65	30
304	C-Flange	55	25	80	36
304	Solid Input	60	27	81	37
306	C-Flange	75	34	100	45
306	Solid Input	84	38	105	48
307	C-Flange	154	70	179	81
307	Solid Input	185	84	206	94
308	C-Flange	236	107	261	118
308	Solid Input	267	121	288	131
309	C-Flange	443	201	524	238
309	Solid Input	631	286	705	320
310	C-Flange	650	295	731	332
310	Solid Input	791	359	866	393
312	C-Flange	1433	650	1514	687
312	Solid Input	1565	710	1639	744

† Subject to change unless certified by the Factory.



866-REXNORD/866-739-6673 (Within the U.S.)
+1 414-643-2366 (Outside the U.S.)
www.rexnord.com

Why Choose Rexnord?

When it comes to providing highly engineered products that improve productivity and efficiency for industrial applications worldwide, Rexnord is the most reliable in the industry. Commitment to customer satisfaction and superior value extend across every business function.

Delivering Lowest Total Cost of Ownership

The highest quality products are designed to help prevent equipment downtime and increase productivity and dependable operation.

Valuable Expertise

An extensive product offering is accompanied by global sales specialists, customer service and maintenance support teams, available anytime.

Solutions to Enhance Ease of Doing Business

Commitment to operational excellence ensures the right products at the right place at the right time.

REXNORD

Rexnord Company Overview

Rexnord is a growth-oriented, multi-platform industrial company with leading market shares and highly trusted brands that serve a diverse array of global end markets.

Process & Motion Control

The Rexnord Process & Motion Control platform designs, manufactures, markets and services specified, highly engineered mechanical components used within complex systems where our customers' reliability requirements and the cost of failure or downtime are extremely high.

Water Management

The Rexnord Water Management platform designs, procures, manufactures and markets products that provide and enhance water quality, safety, flow control and conservation.